

TECHNICAL MANUAL

MOOVAIR MODEL	FACTORY CODE	PRODUCT CODE
DMA06HIW25230E8	MSEP8-06HRFN1-MY5W	22022011017201
DMA09HIW25230E8	MSEP8-09HRFN1-MY5W(GA)	22022011016181
DMA12HIW25230E8	MSEP8-12HRFN1-MW5W(GA)	22022011016261
DMA18HIW25230E8	MSEPC-18HRFN1-MU0W	22022011016461
DMA24HIW25230E8	MSEPD-24HRFN1-MU0W	22022011016422
DUA09HICU230X5	CCA3U-09HRFN1-M(C)	22022511000703
DUA12HICU230X5	CCA3U-12HRFN1-M(C)	22022511000710
DUA18HICU230X5	CCA3U-18HRFN1-M(C)	22022511000711
DUA24HICU230X5	MCD1-24HRFN1-MT0W(GA)	22022511003396
DUA36HICU230X5	MCD1-36HRFN1-M(GA)	22022511003496
DUA48HICU230X5	MCD1-48HRFN1-M(GA)	22022511003497
DUA09HIDU230X5	MTIU-09HWFN1-M	22023011003874
DUA12HIDU230X5	MTIU-12HWFN1-M	22023011003875
DUA18HIDU230X5	MTIU-18HWFN1-M	22023011003474
DUA24HIDU230X5	MTIU-24HWFN1-M	22023011003414
DUA12HIFU230E5	CFAU-12HRFN1-M(C)	22022611000024
DUB12HIFU230X5A	MFA2U-12HRFN1-MW5W	22022611000207
DMA18HOM23230X2	M2OA-18HFN1-M	22022316001345
DMA27HOM23230X2	M3OJ-27HFN1-M	22022316001285
DMA36HOM23230X2	M4OG-36HFN1-M	22022316001305
DMA48HOM23230X2	M5OG-48HFN1-M	22022316001646
DMA18HOM25230X3	M2OI-18HFN1-M	22022316001286
DMA27HOM25230X3	M3OI-28HFN1-M	22022316001306
DMA36HOM25230X3	M4OI-36HFN1-M	22022316001645
DMA48HOM25230X3	M5OG-48HFN1-M-[X]	22022316001165



TM_MULTI_R410A_3D INV_US_S_NA_2204

MULTI SPLIT TYPE

R410A 3D INVERTER CONTROL

TECHNICAL MANUAL

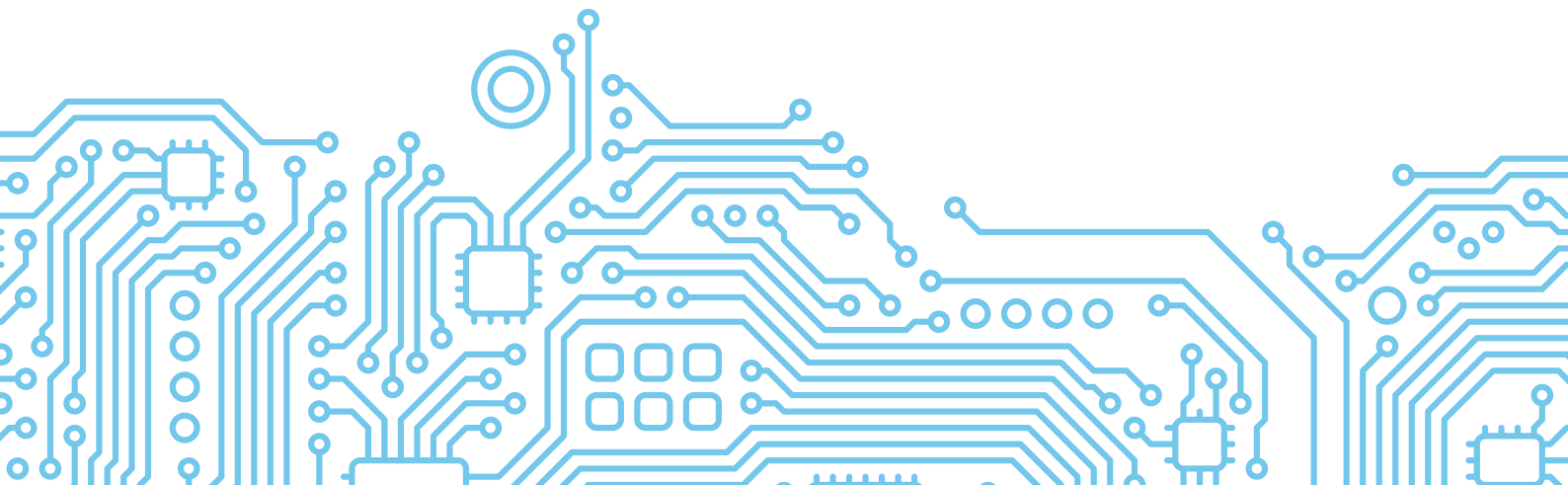

Table of Contents

Page

1. Specifications	4
1. Model Reference	
2. External Appearance	
3. Features	
4. Part names of Indoor units	
5. General Specifications	
6. Indoor Unit Combination	
7. Dimensional Drawings	
8. Centre of Gravity	
9. Air Velocity and Temperature Distributions	
10. Electrical Wiring Diagrams	
11. Refrigerant Cycle Diagrams	
12. Capacity Tables	
13. Noise Criterion Curves	
14. Electrical Characteristics	
15. Static Pressure	
2. Product Features	147
1. Operation Modes and Functions	
2. Remote Controller Functions	
3. Troubleshooting	174
1. Safety Caution	
2. General Troubleshooting	
3. Complain Record Form	
4. Information Inquiry	

Table of Contents

Page

- 5. Outdoor Unit Point Check Function
- 6. Error Diagnosis and Troubleshooting Without Error Code
- 7. Quick Maintenance by Error Code
- 8. Troubleshooting by Error Code
- 9. Check Procedures

Appendix 238

- i) Temperature Sensor Resistance Value Table for T1,T2,T3 and T4 (°C – K)
- ii) Temperature Sensor Resistance Value Table for TP (°C – K)
- iii) Pressure On Service Port

Specifications

Contents

1.	Model Reference.....	5
2.	External Appearance	7
3.	Features	9
4.	Part names of Indoor units	19
5.	General Specifications.....	23
6.	Indoor Unit Combination	34
7.	Dimensional Drawings	36
8.	Centre of Gravity	47
9.	Air Velocity and Temperature Distributions	49
10.	Electrical Wiring Diagrams.....	107
11	Refrigerant Cycle Diagrams	120
12	Capacity Tables	124
13.	Noise Criterion Curves.....	126
14.	Electrical Characteristics	141
15.	Static Pressure.....	143

1. Model Reference

Refer to the following table to determine the specific indoor and outdoor unit model number of your purchased equipment.

Indoor Unit		Outdoor Unit	Power Supply
A6 Duct type	MTIU-09HWFN1-M	M2OA-18HFN1-M M3OJ-27HFN1-M M4OG-36HFN1-M M5OG-48HFN1-M	1Phase, 208/230V~, 60Hz
	MTIU-12HWFN1-M		
	MTIU-18HWFN1-M		
	MTIU-24HWFN1-M		
Compact Cassette type	MCA3U-09HRFN1-M(C)		
	MCA3U-12HRFN1-M(C)		
	MCA3U-18HRFN1-M(C)		
New 4-way Cassette type	MCD1-24HRFN1-MTOW(GA)		
Floor ceiling type	MUEU-18HRFN1-M(C)		
	MUEU-24HRFN1-M(C)		
Air Handler type	MVC-18HWFN1-MW(GA)		
	MVC-23HWFN1-M		
	MVC-30HWFN1-M(GA)		
	MVCU-36HWFN1-M(GA)		

Indoor Unit		Outdoor Unit	Power Supply
Wall mounted type-Aurora	MSABB-09HRFN1-MX0W	M20A-18HFN1-M M30J-27HFN1-M M40G-36HFN1-M M50G-48HFN1-M	1Phase, 208/230V~, 60Hz
	MSABB-12HRFN1-MV0W		
	MSABE-18HRFN1-MW5W		
	MSABE-24HRFN1-MU0W		
	MSABF-30HRFN1-MR0W		
	MSABF-36HRFNX-MQ0W		
Wall mounted type-ALL Easy Pro	MSEPB-06HRFN1-MY5W		
	MSEPB-09HRFN1-MY5W(GA)		
	MSEPB-12HRFN1-MW5W(GA)		
	MSEPC-18HRFN1-MU0W		
	MSEPD-24HRFN1-MU0W		
	MSEPD-30HRFN1-MS8W		
	MSEPD-36HRFN1-MQ0W		
Wall mounted type-INFINI	MSAG11A-06HRFN1-MU0W		
	MSAG11B-09HRFN1-MX7W(GA)		
	MSAG11B-12HRFN1-MV0W(GA)		
	MSAG11D-18HRFN1-MT8W		
	MSAG11D-23HRFN1-MU0W		
	MSAGF-30HRFN1-MT0W		
	MSAGF-36HRFNX-MR0W		

2. External Appearance

2.1 Indoor Unit

Compact Four-way Cassette Type



New Four-way Cassette Type



Floor Ceiling Type



A6 Duct type

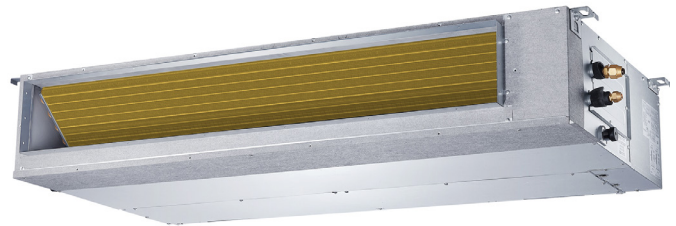

Air Handler Type



Wall Mounted Type-Aurora

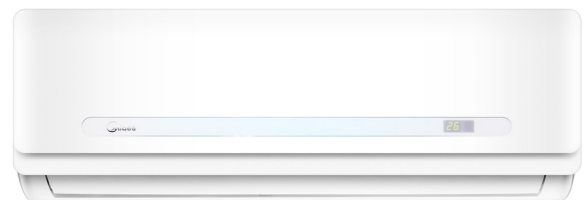

Wall Mounted Type- INFINI



Wall Mounted Type-All Easy Pro



2.2 Outdoor Unit

Single Fan Outdoor Unit



Double Fan Outdoor Unit



3. Functions

3.1 A6 Duct Type

3.1.1 High Static Pressure

Capable to be installed in various applications that requires static pressure of 160Pa.

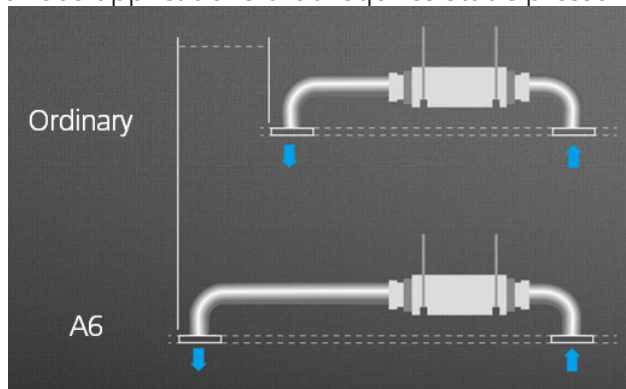

3.1.2 Eccentric Fan Design

New eccentric fan design improves the airflow at the air outlet, resulting better performance.

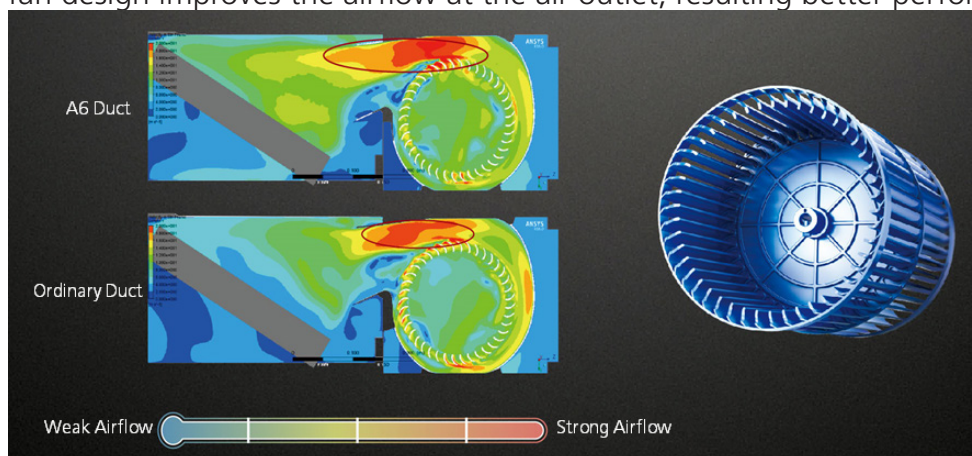

3.1.3 Slim Design

The industry lowest height is designed to be fitted into tight roof space.

3.1.4 2 Types Installation

Two types of installation methods can be selected: ceiling concealed and floor concealed(optional)



3.1.5 Flexible Air Intake

The frame size of air inlet in rear and bottom is the same. It's very easy to switch to match different applications.

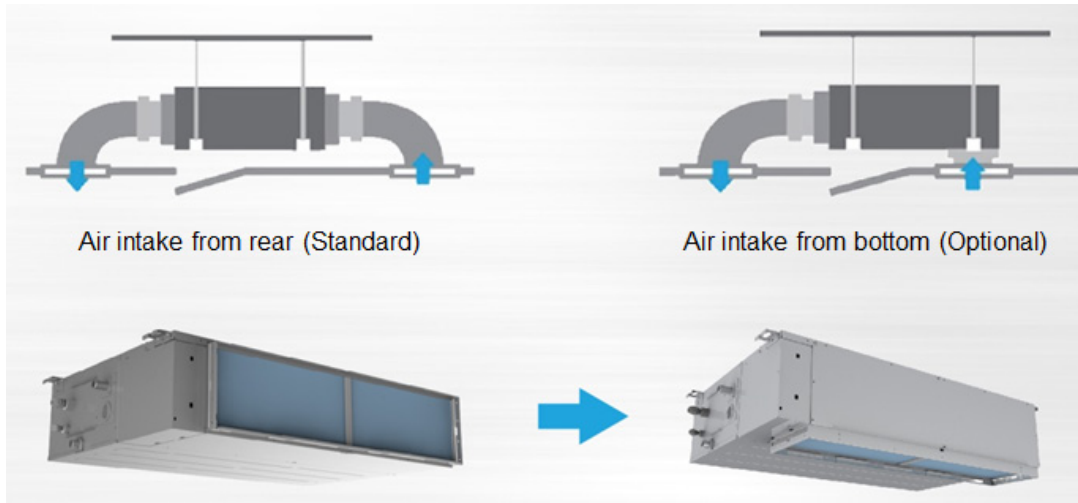

3.1.6 Built-in Drain Pump

The built-in drain pump can lift condensing water up to 750mm.

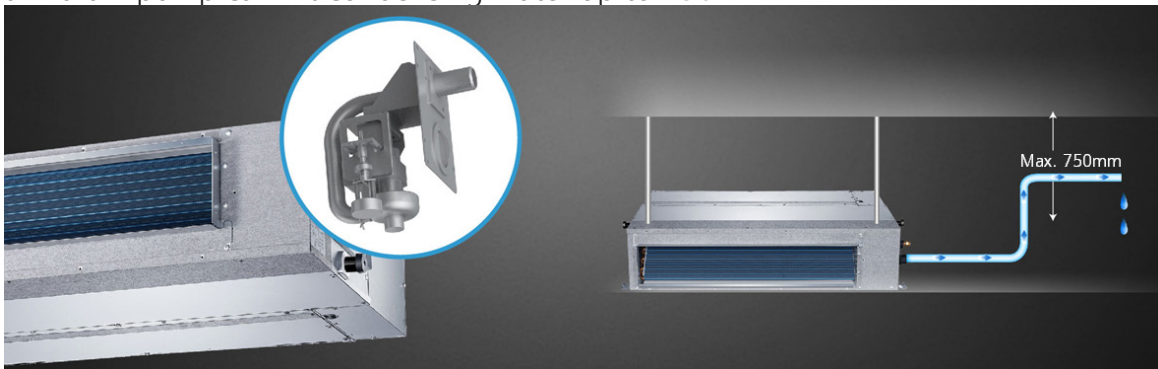

3.1.7 Easy Clean

You can pull out the filter from left, right, or from the bottom for easy cleaning.

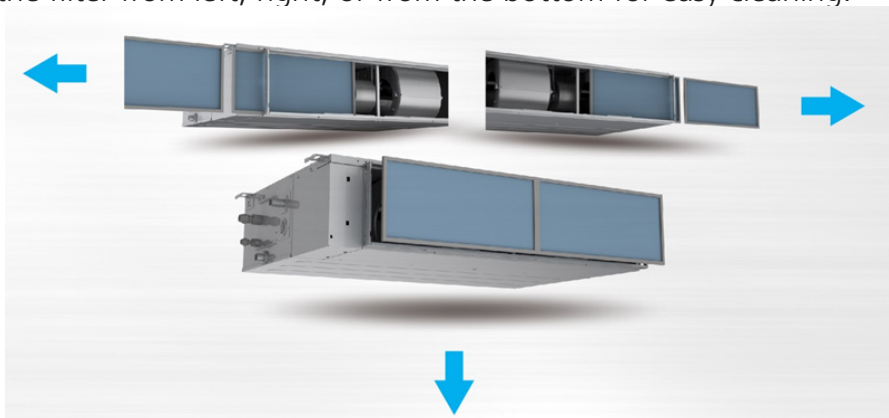

3.2 Compact Cassette Type

3.2.1 Compact design

- The body size is 570×260×570mm, it's just smaller than the ceiling board, so it's very easy for installation and will not damage the decoration. The panel size is 647×50×647mm.
- The hooks are designed in the four corners of the body, which can save installation space.

3.2.2 Fire-proof Controller Box

- Electrical control box adopts new design which can meet higher fire safety requirements.

3.2.3 Reserved remote on-off and alarm ports(Optional for fixed-speed units, standard for inverter units)

- Remote on-off: With the reserved ports, a remote switch can be easily connected to realize remote control.
- Alarm: The built-in PCB can output alarm signal, which achieve setting up an external alarm light or vibration gauge possible.



3.2.4 Build-in Drain Pump

- The drain pump can lift the condensed water up to 750mm.
- It's convenient to install drainage piping under most space condition.

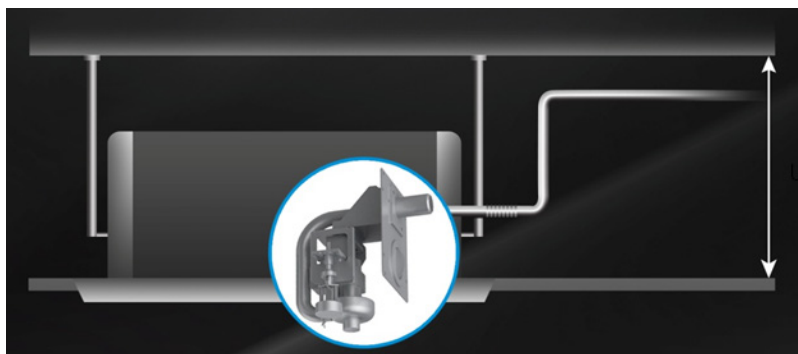

3.2.5 Fresh Air

- Fresh air intake function brings you fresh and comfortable air feeling.

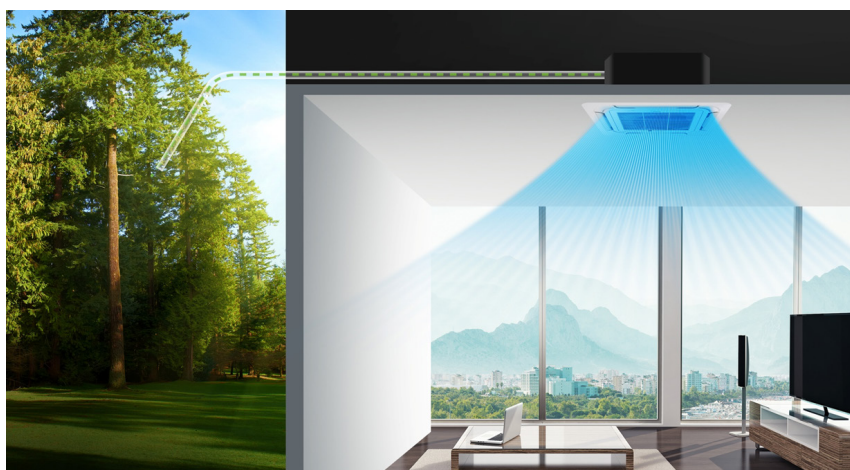

3.2.6 Wired Controller(Optional)

- Compared with infrared remote controller, wired controller can be fixed on the wall and avoid mislaying. It's mainly used for commercial zone and makes air conditioner control more convenient.

3.3 New 4-way Cassette Type

3.3.1 360° Air Flow

- 360°directional wind can deliver air evenly throughout every corner in any space, reducing hot and cold spots in the room.

3.3.2 Easy Installation

- The Cassette is much slimmer due to the redesigned heat exchanger and overall structures. It now requires less space for installation.

3.3.3 Reserved Air Outlet for Duct

- The cassette unit is equipped with reserved connection for air outlet at the side of the indoor unit. It can connect to an air duct to cool a small room nearby.

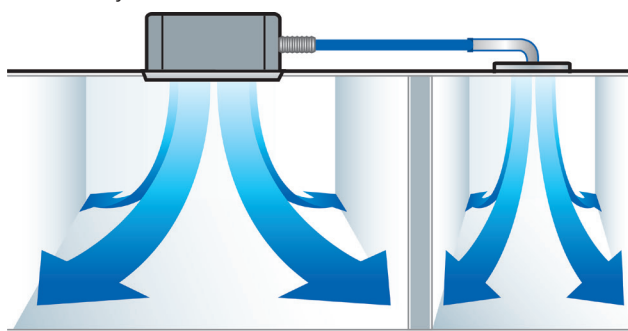

3.3.4 Reserved remote on-off and alarm ports(Optional for fixed-speed units, standard for inverter units)

- Remote on-off: With the reserved ports, a remote switch can be easily connected to realize remote control.
- Alarm: The built-in PCB can output alarm signal, which achieve setting up an external alarm light or vibration gauge possible.

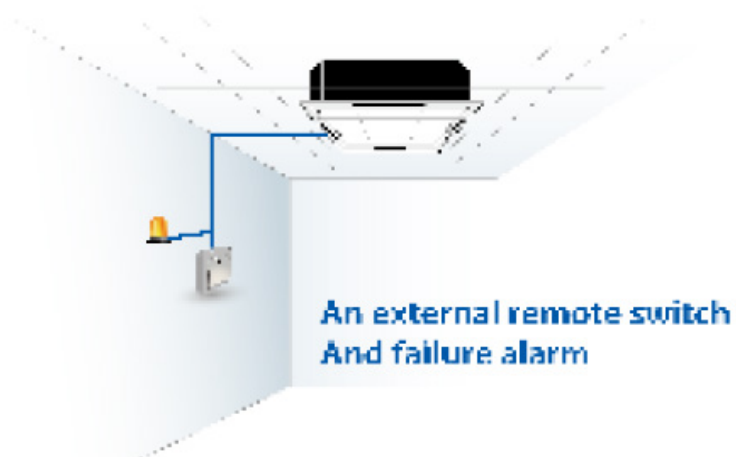

3.3.5 Fresh Air

- Fresh air intake function brings you fresh and comfortable air feeling.



3.3.6 Wired Controller(Optional)

- Compared with infrared remote controller, wired controller can be fixed on the wall and avoid mislaying. It's mainly used for commercial zone and makes air conditioner control more convenient.

3.4 Floor Ceiling Type

3.4.1 Easy installation-2 Style Installation

- Fashionable design and streamline appearance, suitable for different room style.

3.4.2 3D Airflow

- Vertical air flow and horizontal airflow can be adjusted by remote controller to direct air flow to every corner of the room.

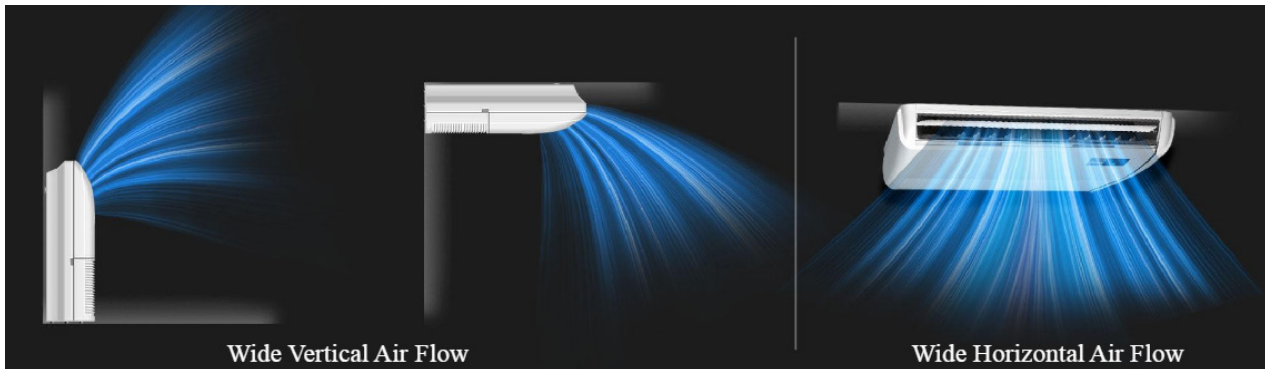

3.4.3 Easy Maintenance-Universal Spare Parts

- More than 60% parts and assemblies (such as fan wheel, plastic cases, metal parts etc.) are universal for 3 different bodies, which makes maintenance much easier.

3.4.4 Fresh Air

- Fresh air intake function brings you fresh and comfortable air feeling.

3.4.5 Healthy Filters(Optional)

- Various of healthy filters can be chosen to fix on the machine.

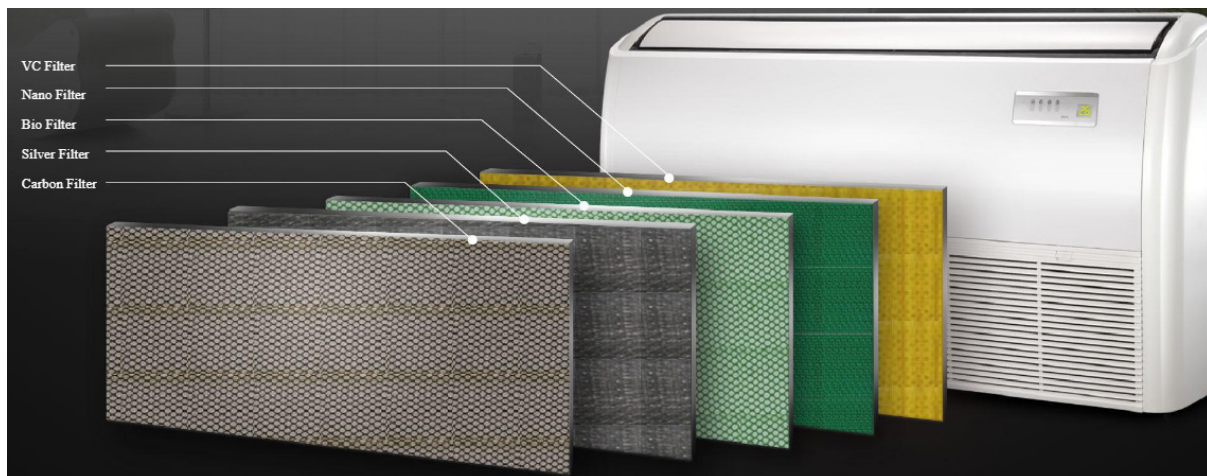

3.5 Air Handler Type

3.5.1 Full Multi-position installation

- This AHU is capable of upflow, downflow, horizontal left, or horizontal right configurations.

3.5.2 Installation Convenience

- It simplifies the airflow volume adjustment process and saves lots of installation efforts. The traditional adjustment method needs the installers to manually set the motor speed, according to the installation instruction and ducting design. It takes lots of time if this thing doesn't go well and decreases the marginal profits.

3.5.3 Easy Fault Code Checking

- Thanks to advanced mutual data communication technology, the AHU system can intelligently self-detecting the failure cause and generate a corresponding code.
- Installer or user can easily check the fault code displayed on the electric function board by just opening the lid.
- It helps you proactively determine the failure cause, prepare for repairing parts ahead of field maintenance work, greatly improve the work efficiency.

3.5.4 Nitrogen Charge and Leakage Check Valve

- Midea AHU indoor unit is standard with Nitrogen injection to maintain positive pressure of the indoor unit. It is easy to check from the check valve whether there is leakage in the evaporator or not.

3.5.5 Automatic Airflow Adjustment

- During the operation, when the dust filter or evaporator is clogged with dust, the load of the system and motor torque increases. The MPU(microprocessor) on the unit can detect this change and adjust the fan speed to keep the CFM stable.

3.6 Wall Mounted Type(Aurora)

3.6.1 Powerful Cooling

- The optimized indoor and outdoor unit design improves cooling performance and generate a strong air flow as long as 12m and air speed $\geq 0.3\text{m/s}$, keeping your entire room cool all through the summer.

3.6.2 3D Air Flow

- The unit has horizontal swing and auto vertical swing function, which supplies more even and comfortable air flow.



3.6.3 Golden Fin

- The unique anticorrosive golden coating on the heat exchangers can withstand the salty air, rain and other corrosive elements. It also effectively prevents bacteria from breeding and improves heat efficiency.
- After one year of operation, the prototype with golden coating shows better performance in all working conditions than the prototype with blue coated foil.
- Dry-wet cycle tests 3000 times (equivalent to using an air conditioner for 10 years): the golden fin still has good hydrophilicity (hydrophilic angle $\leq 30^\circ$).

3.6.4 Fireproof Electronic Control Box

- The electric control box uses ABS material with a 5VA flame retardant rating, and the outer surface is covered with sheet metal, which isolates the electric control box from fire.

3.6.5 ECO mode

- The air conditioner is equipped with the ECO energy-saving technology, which perfectly synergized with highly efficient inverter technology. You can indulge in comfortable coolness while significantly reducing energy consumption over 8 hours.



3.7 Wall Mounted Type(INFINI)

3.7.1 Long-Distance Windblast

The optimized air duct design synergizes with the turbo fan speed to deliver longer airflow, so you can enjoy the cool air with distance reaching up to 25 meters*.

*only applies to 90 IDU.

3.7.2 3D Airflow

The directional air-outlet moves automatically both horizontally and vertically, directing nice and cool airflow to cover every corner of the room.

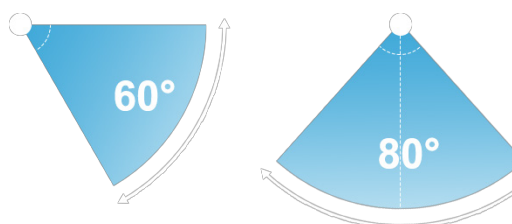

3.7.3 Wind Avoid Me

Avoid wind blowing directly on you by using the remote to adjust the wind direction.

3.7.4 i-Clean

- The i-Clean Technology washes away dust, mold, and grease that may cause odors when it adheres to the heat exchanger by automatically freezing and then rapidly thawing the frost.
- The internal wind wheel then keeps operating to blow-dry the evaporator, thus preventing the growth of mold and keeping the inside clean.

3.7.5 Energy Saving Econo+ mode

Just touch the Econo+ button to activate the mode. Your AC can keep you cool over an 8-hour night period with as little as 1 kWh energy consumption, saving 71%.

3.7.6 Gear Change

Midea inverter air conditioners offer three operating power options: 50%, 75%, and 100%.

You can choose a lower power level to conserve energy.

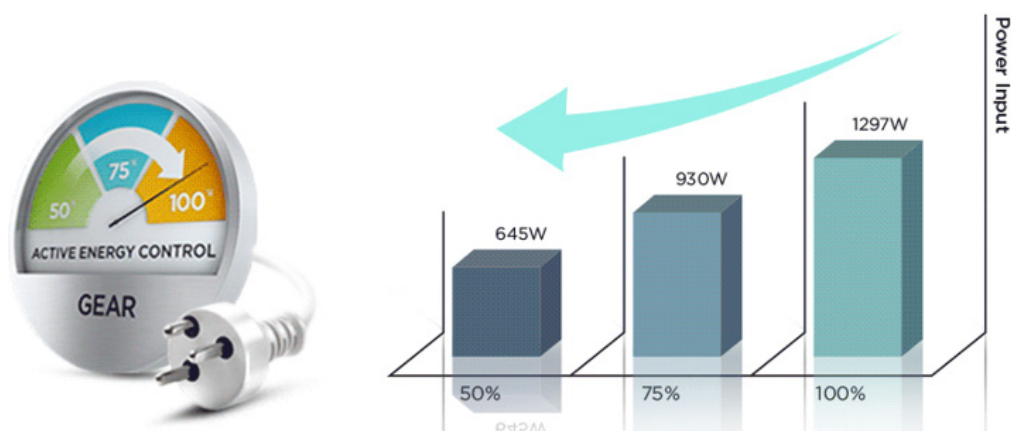

3.8 Wall Mounted Type(All Easy Pro)

3.8.1 Compact Body, Better Efficiency

795mm * 295mm.Owing to the re-construction, a smaller but stronger machine was invented.

An higher energy efficiency standard is achieved.

3.8.2 Space Released for More Air In N Out

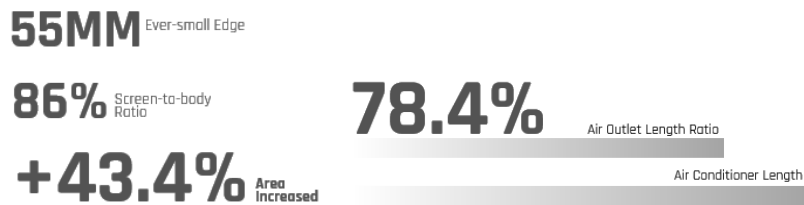

3.8.3 Shorter Distance Required, for More Flexibility to Enjoy.

Thanks to the air-intake's enlargement, the air conditioner operates smoothly with low noise and sufficient cooling capacity even being fixed closely to the ceiling.

To Ceiling Distance Required

Ordinary AC	ALL EASY Pro
15 ~ 20cm	5cm

3.8.4 Easy Disassemble

Thanks to the Snap-and-Snap design of the hasps, We get rid of the fuss for 7 or more screws in different places of a typical IDU to disassemble.

The whole disassemble process only costs you just 1 minute

3.8.5 Easy Clean-Quick Cleaning from the Top

Thanks to the Mag Pull design – 6 round magnetic connectors on the filter, the top cover filter can be easily removed and put back just within 1 soft 'click'. The whole process is free of dust-stir.

No need to bother opening up the front panel any more. Clean your filter as often as you want.

3.8.6 Easy Installation-Just Put It On,Simply

1. Mark the position, with Scale-on-Plate, then Fix the installation,
2. Horizontally measure with the Built-In Level Bubble and Pin other nails
3. AC on the wall.



4. Part names of Indoor units

A6 Duct Type

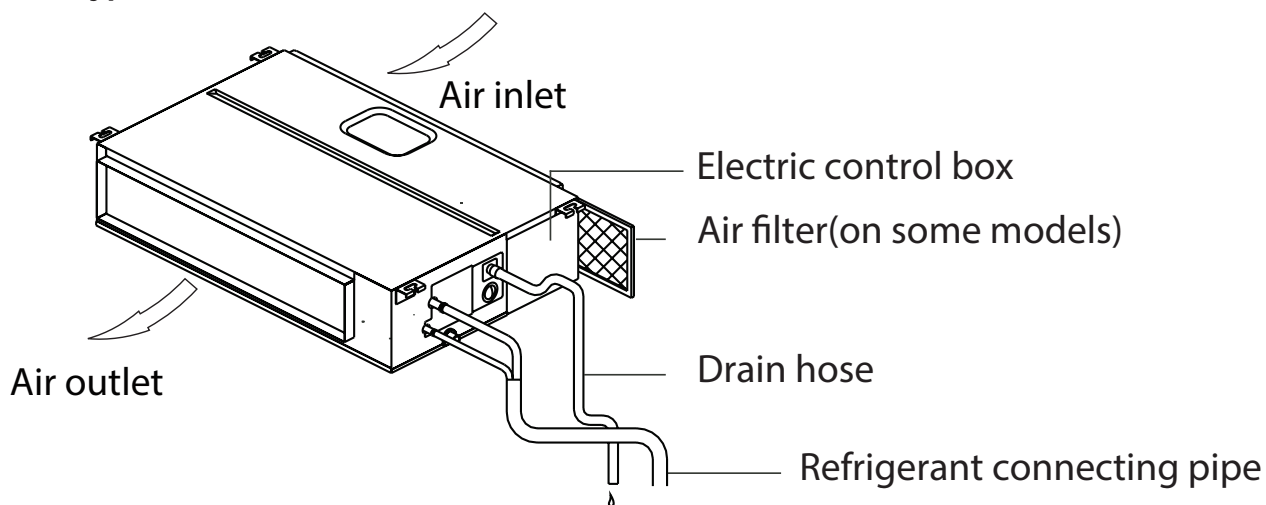

Compact Cassette Type

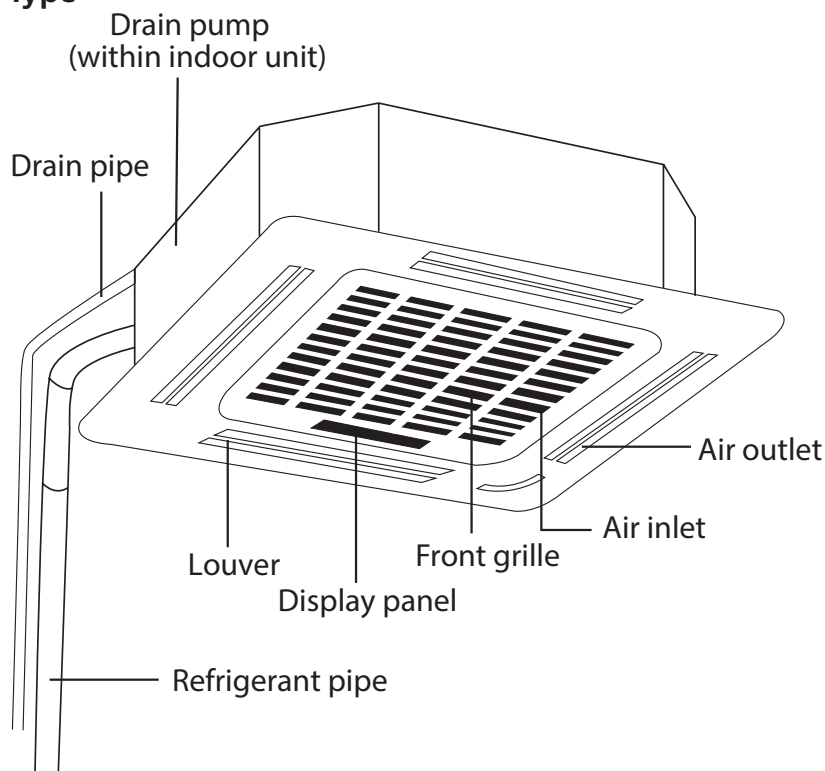

New 4-way Cassette Type

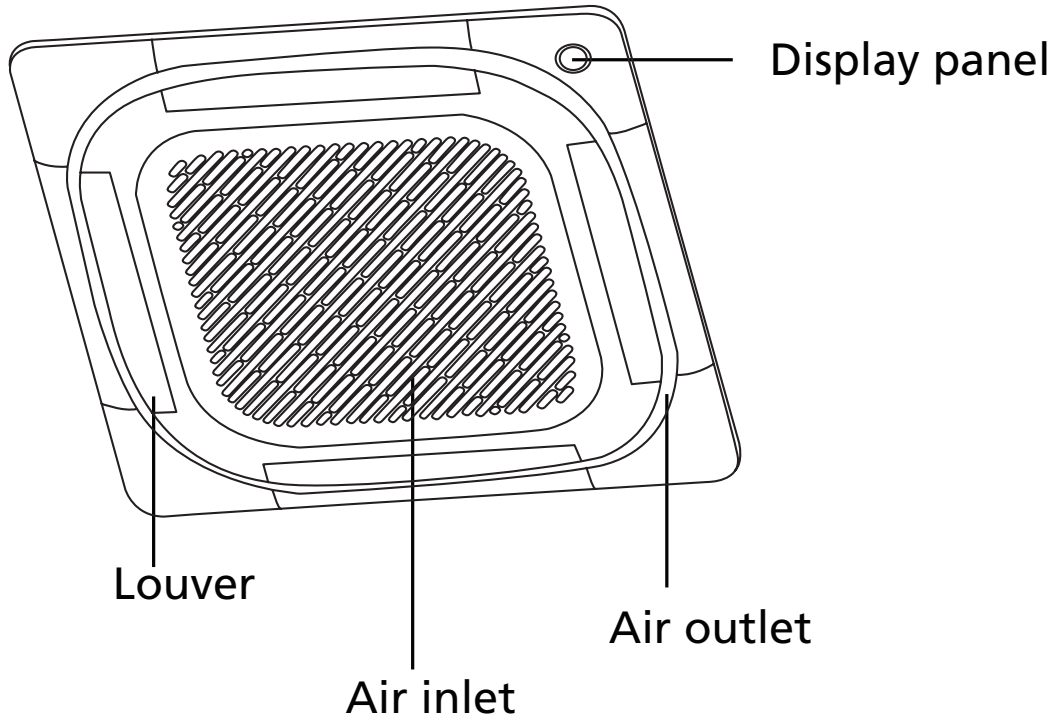

Floor Ceiling Type

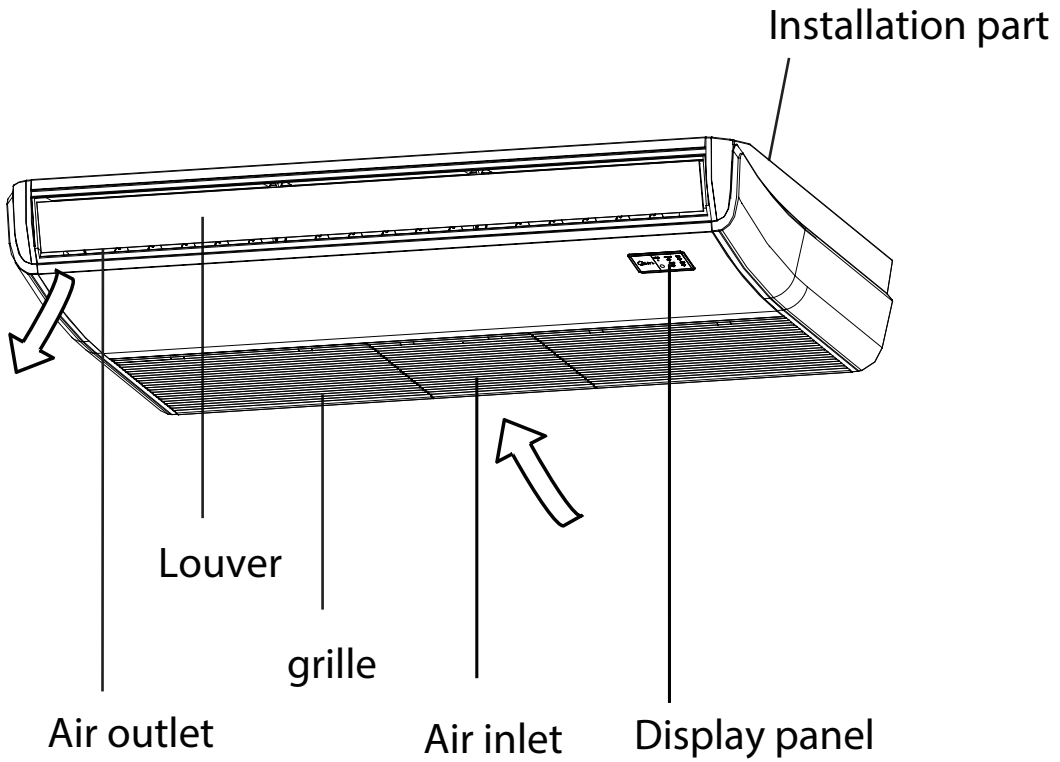

Air Handler Type

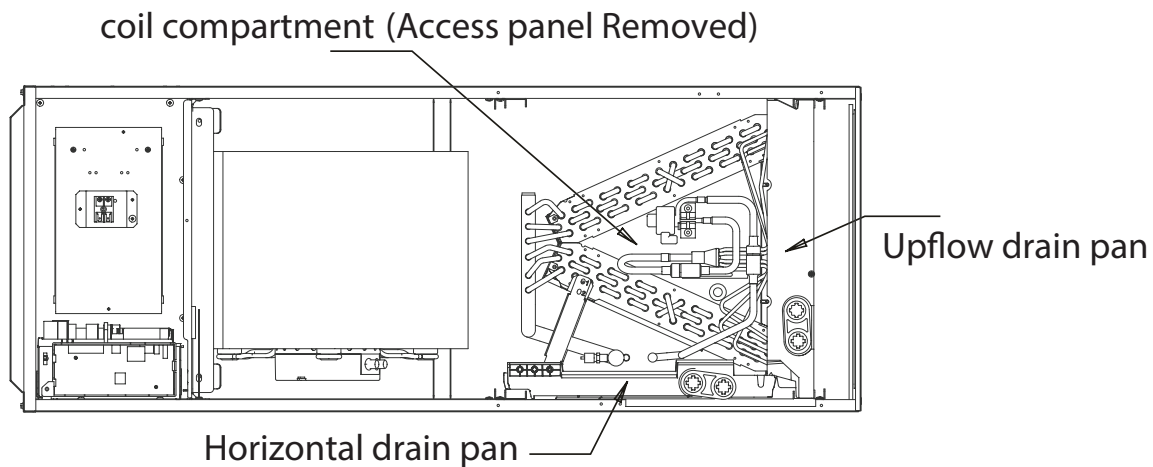

Wall Mounted Type-Aurora & INFINI

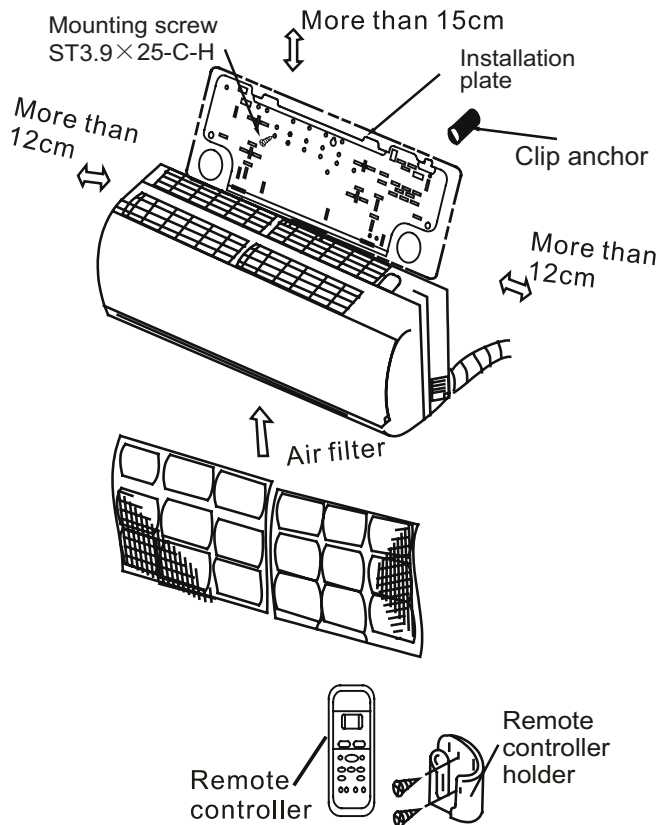

Wall Mounted Type-All Easy Pro

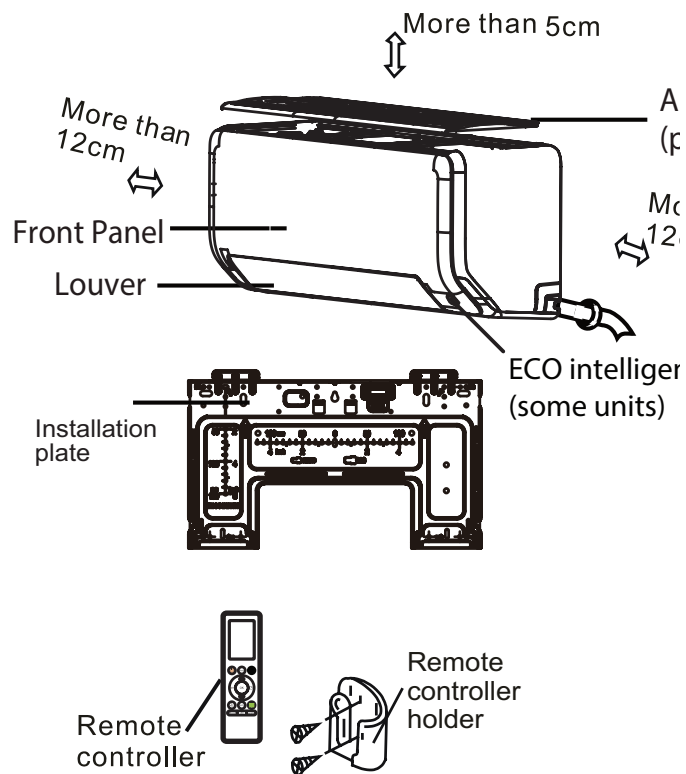

5. General Specifications

Indoor model			MTIU-09HWFN1-M	MTIU-12HWFN1-M	MTIU-18HWFN1-M	MTIU-24HWFN1-M
Power supply (Indoor)		V- Ph-Hz	208/230-1-60	208/230-1-60	208/230-1-60	208/230-1-60
Indoor fan motor	Model		ZKFN-55-8-22	ZKFN-55-8-22	ZKFN-160-8-1-2	ZKFN-160-8-1-2
	Qty		1	1	1	1
	Input	W	130.0	130.0	90.0	90.0
	RLA	A	1.11	1.11	1.2	1.5
	LRA	A	/	/	/	/
	Capacitor	uF	/	/	/	/
	Speed(Hi/Med/Lo)	r/min	1170/1030/850	1170/1030/850	850/700/450	880/820/690
Indoor coil	a.Number of rows		3	3	3	3
	b.Tube pitch(a)x row pitch(b)	mm	21x13.37	21x13.37	21x13.37	21x13.37
	c.Fin spacing	mm	1.4	1.4	1.4	1.4
	d.Fin type (code)		Hydrophilic aluminum	Hydrophilic aluminum	Hydrophilic aluminum	Hydrophilic aluminum
	e.Tube outside dia.and type	mm	Φ7 Inner groove tube	Φ7 Inner groove tube	Φ7 Inner groove tube	Φ7 Inner groove tube
	f.Coil length x height x width	mm	526x210x40.11	526x210x40.11	695x252x40.11	915x294x40.11
	g.Number of circuits		4	4	4	7
Indoor air flow (Hi/Med/Lo)		m3/h	600/480/300	600/480/300	900/765/630	1320/1180/740
		CFM	353/282/176	353/282/176	529/450/371	775/693/435
ESP	Rated	Pa	25	25	25	25
	Range	Pa	0-40	0-40	0-100	0-160
Indoor noise level (Hi/Med/Lo)(Standard pressure)		dB(A)	38/32/25	38/33.5/26	39/37/35	44/41/34
Indoor unit	Dimension(W*D*H)	mm	700x506x200	700x506x200	880x674x210	1100x774x249
		inch	27.56x19.92x7.87	27.56x19.92x7.87	34.65x26.54x8.27	43.31x30.47x9.80
	Packing(W*D*H)	mm	860x540x285	860x540x285	1070x725x280	1305x805x315
		inch	33.86x21.26x11.22	33.86x21.26x11.22	42.13x28.54x11.02	51.38x31.69x12.40
	Net/Gross weight	Kg	17.7/21.9	17.8/22	25.1/30.4	41/48
		lb	39.02/48.28	39.24/48.50	55.34/67.02	90.39/105.82
Design pressure		MPa	4.2/1.5	4.2/1.5	4.2/1.5	4.2/1.5
Drainage water pipe dia.		mm	ODΦ25	ODΦ25	ODΦ25	ODΦ25
Refrigerant piping	Liquid side/ Gas side	mm(inch)	Φ6.35/Φ9.52(1/4"/3/8")	Φ6.35/Φ12.7(1/4"/1/2")	Φ6.35/Φ12.7(1/4"/1/2")	Φ9.52/Φ15.9(3/8"/5/8")
Controller			Wired Control	Wired Control	Wired control	Wired control
Operation temperature		°C	17~30	17~30	17~30	17~30
		°F	63~86	63~86	63~86	63~86
Room temperature	Cooling	°C	17~32	17~32	17~32	17~32
		°F	63~90	63~90	63~90	63~90
	Heating	°C	0~30	0~30	0~30	0~30
		°F	32~86	32~86	32~86	32~86
Qty'per 20' /40' /40'HQ			214/416/519	214/416/519	120/264/297	77/161/198

Notes:

1) Capacities are based on the following conditions:

Cooling: - Indoor Temperature 26.7°C(80°F) DB /19.4 °C(67°F) WB
 -Outdoor Temperature 35 °C(95°F) DB /23.9 °C(75°F) WB
 -Interconnecting Piping Length 7.5m
 - Level Difference of Zero.

Heating: - Indoor Temperature 21.1°C(70°F) DB / 15.6°C(60°F) WB
 -Outdoor Temperature 8.3°C(47°F) DB / 6.1°C(43°F) WB
 - Interconnecting Piping Length 7.5 m
 - Level Difference of Zero.

2) Capacities are net capacities.

3) Due to our policy of innovation some specifications may be changed without notification.

Indoor model			MCA3U-09HRFN1-M(C)	MCA3U-12HRFN1-M(C)	MCA3U-18HRFN1-M(C)	MCD1-24HRFN1-MT0W(GA)
Power supply (Indoor)		V- Ph-Hz	208/230-1-60	208/230-1-60	208/230-1-60	208/230-1-60
Indoor fan motor	Model		ZKFP-46-8-1	ZKFP-46-8-1	ZKFP-46-8-1	ZKFN-45-8-1
	Qty		1	1	1	1
	Input	W	45.0	45.0	45.0	65
	RLA	A	0.9	1	1.5	1
	LRA	A	/	/	/	/
	Capacitor	uF	/	/	/	/
	Speed(Hi/Med/Lo)	r/min	600/520/460	680/580/500	730/630/570	680/624/568/512
Indoor coil	a.Number of rows	3.0	1	2	2	2
	b.Tube pitch(a)x row pitch(b)	mm	21x13.37	21x13.37	21x13.37	21x13.37
	c.Fin spacing	mm	1.3	1.3	1.3	1.3
	d.Fin type (code)		Hydrophilic aluminum	Hydrophilic aluminum	Hydrophilic aluminum	Hydrophilic aluminum
	e.Tube outside dia.and type	mm	Φ7 Inner groove tube	Φ7 Inner groove tube	Φ7 Inner groove tube	Φ7,Inner groove tube
	f.Coil length x height x width	mm	1380x210x13.37	1360x210x26.74	1360x210x26.74	2155x168x26.74
	g.Number of circuits		2	4	4	4
Indoor air flow (Hi/Med/Lo)		m3/h	600/520/460	574/490/422	956/825/746	1200/1080/930
		CFM	353/306/271	338/288/248	562/485/439	706/635/547
Indoor sound pressure level (Hi/Med/Lo)		dB(A)	41/39/37	41/38/35	46/43/41	48/45.5/43
Indoor unit	Dimension (W x Dx H)(body)	mm	570x570x260	570x570x260	570x570x260	830x830x205
		inch	22.44x22.44x10.24	22.44x22.44x10.24	22.44x22.44x10.24	32.68x32.68x8.07
	Packing (W x Dx H)(body)	mm	662x662x317	662x662x317	662x662x317	910x910x250
		inch	26.06x26.06x12.48	26.06x26.06x12.48	26.06x26.06x12.48	35.83x35.83x9.84
	Dimension (W x Dx H)(panel)	mm	647x647x50	647x647x50	647x647x50	950x950x55
		inch	25.47x25.47x1.97	25.47x25.47x1.97	25.47x25.47x1.97	37.4x37.4x2.17
	Packing (W x Dx H)(panel)	mm	715x715x123	715x715x123	715x715x123	1035x1035x90
		inch	28.15x28.15x4.84	28.15x28.15x4.84	28.15x28.15x4.84	40.75x40.75x3.54
	Net/Gross weight(body)	kg	14.5/17.3	16/18.6	16.2/21.3	21.4/25.1
		lb	31.97/38.14	35.27/41.01	35.71/46.96	47.18/55.34
Net/Gross weight	kg	2.5/4.5	2.5/4.5	2.5/4.5	6/9	
	lb	5.51/9.92	5.51/9.92	5.51/9.92	13.23/19.84	
Design pressure		MPa	4.2/1.5	4.2/1.5	4.2/1.5	4.2/1.5
Drainage water pipe dia.		mm	ODΦ25	ODΦ25	ODΦ25	ODΦ32
Refrigerant piping	Liquid side/ Gas side	mm(inch)	Φ6.35/Φ9.52(1/4"/3/8")	Φ6.35/Φ12.7(1/4"/1/2")	Φ6.35/Φ12.7(1/4"/1/2")	Φ9.52/Φ15.9(3/8"/5/8")
Controller			Remote Control	Remote Control	Remote Control	Remote control
Operation temperature		°C	17~30	17~30	17~30	16~30
		°F	63~86	63~86	63~86	60~86
Room temperature	Cooling	°C	17~32	17~32	17~32	16~32
		°F	63~90	63~90	63~90	60~90
	Heating	°C	0~30	0~30	0~30	0~30
		°F	32~86	32~86	32~86	32~86
Qty'per 20' /40' /40'HQ			186/375/429	186/375/429	186/375/429	108/234/260

Notes:

1) Capacities are based on the following conditions:

Cooling: - Indoor Temperature 26.7°C(80°F) DB /19.4 °C(67°F) WB Heating: - Indoor Temperature 21.1°C(70°F) DB / 15.6°C(60°F) WB
 -Outdoor Temperature 35 °C(95°F) DB /23.9 °C(75°F) WB -Outdoor Temperature 8.3°C(47°F) DB / 6.1°C(43°F) WB
 -Interconnecting Piping Length 7.5m - Interconnecting Piping Length 7.5 m
 - Level Difference of Zero. - Level Difference of Zero.

2) Capacities are net capacities.

3) Due to our policy of innovation some specifications may be changed without notification.

Indoor model			MUEU-18HRFN1-M(C)	MUBU-24HRFN1-M(C)
Power supply (Indoor)		V- Ph-Hz	208/230-1-60	208/230-1-60
Indoor fan motor	Model		ZKFN-90-8-1	ZKFN-90-8-1
	Qty		1	1
	Input	W	96	96
	RLA	A	1.5	2
	LRA	A	/	/
	Capacitor	uF	/	/
	Speed(Hi/Med/Lo)	r/min	950/850/750	1350/1260/1120
Indoor coil	a.Number of rows		2	3
	b.Tube pitch(a)x row pitch(b)	mm	21x13.37	21x13.37
	c.Fin spacing	mm	1.3	1.3
	d.Fin type (code)		Hydrophilic aluminum	Hydrophilic aluminum
	e.Tube outside dia.and type	mm	Φ7 Inner groove tube	Φ7 Inner groove tube
	f.Coil length x height x width	mm	795x294x26.74	795x294x40.11
	g.Number of circuits		6	7
Indoor air flow (Hi/Med/Lo)		m ³ /h	932/825/715	1290/1204/1017
		CFM	548/485/421	759/708/598
Indoor noise level (Hi/Med/Lo)		dB(A)	47/44/39	58.5/55/52
Indoor unit	Dimension(W*D*H)	mm	1068x675x235	1068x675x235
		inch	42.05x26.57x9.25	42.05x26.57x9.25
	Packing(W*D*H)	mm	1145x755x318	1145x755x318
		inch	45.08x29.72x12.52	45.08x29.72x12.52
	Net/Gross weight	kg	25.9/31	27.5/32.7
		lb	57.10/68.34	60.63/72.09
Design pressure		MPa	4.2/1.5	4.2/1.5
Drainage water pipe dia.		mm	ODΦ25	ODΦ25
Refrigerant piping	Liquid side/ Gas side	mm(inch)	Φ6.35/Φ9.52(1/4"/3/8")	Φ9.52/Φ15.9(3/8"/5/8")
Controller			Wired Control	Wired control
Operation temperature		°C	17~30	17~30
		°F	63~86	63~86
Room temperature	Cooling	°C	17~32	17~32
		°F	63~90	63~90
	Heating	°C	0~30	0~30
		°F	32~86	32~86
Qty'per 20' /40' /40'HQ			102/220/252	102/220/252

Notes:

1) Capacities are based on the following conditions:

Cooling: - Indoor Temperature 26.7°C(80°F) DB /19.4 °C(67°F) WB

-Outdoor Temperature 35 °C(95°F) DB /23.9 °C(75°F) WB

-Interconnecting Piping Length 7.5m

- Level Difference of Zero.

Heating: - Indoor Temperature 21.1°C(70°F) DB / 15.6°C(60°F) WB

-Outdoor Temperature 8.3°C(47°F) DB / 6.1°C(43°F) WB

- Interconnecting Piping Length 7.5 m

- Level Difference of Zero.

2) Capacities are net capacities.

3) Due to our policy of innovation some specifications may be changed without notification.

Indoor model		MVC-18HWFN1-MW(GA)	MVC-23HWFN1-M	MVC-30HWFN1-M(GA)	MVCU-36HWFN1-M(GA)	
Power supply (Indoor)		V- Ph-Hz	208/230-1-60	208/230-1-60	208/230-1-60	208/230-1-60
Indoor fan motor	Model		ZKFD-250-8-1	ZKFD-250-8-1	ZKFD-375-8-1-1	ZKFD-375-8-1-1
	Qty		1	1	1	1
	Input	W	67.8	67.8	168	168
	RLA	A	2	3	3.5	4
	LRA	A	/	/	/	/
	Capacitor	uF	/	/	/	/
	Speed(Hi/Med/Lo)	r/min	/	/	/	/
Indoor coil	a.Number of rows		3	3	4	4
	b.Tube pitch(a)x row pitch(b)	mm	21x13.37	21x13.37	21x13.37	21x13.37
	c.Fin spacing	mm	1.3	1.3	1.3	1.3
	d.Fin type (code)		Hydrophilic aluminum	Hydrophilic aluminum	Hydrophilic aluminum	Hydrophilic aluminum
	e.Tube outside dia.and type	mm	Φ7,Inner groove tube	Φ7,Inner groove tube	Φ7,Inner groove tube	Φ7,Inner groove tube
	f.Coil length x height x width	mm	415*336*40.11*2	415*336*40.11*2	415*546*53.48*2	415*546*53.48*2
	g.Number of circuits		6	6	10	10
Indoor air flow (Hi/Med/Lo)		m3/h	980/900/830	1290/1180/1070	1520/1370/1210	1840/1650/1470
		CFM	576/529/488	759/694/629	894/806/712	1082/971/865
ESP	Rated	Pa	25	25	37	37
	Range	Pa	0-200	0-200	0-200	0-200
Indoor noise level (Hi/Med/Lo)(Standard pressure)		dB(A)	38.5/35/34	42/40/38.0	40/38/36	50/45/42.5
Indoor unit	Dimension(W*D*H)	mm	534x445x1143	534x445x1143	534x534x1245	534x534x1245
		inch	21.02x17.52x45.00	21.02x17.52x45.00	21.02x21.02x49.02	21.02x21.02x49.02
	Packing(W*D*H)	mm	675x530x1235	675x530x1235	675x620x1335	675x620x1335
		inch	26.57x20.87x48.62	26.57x20.87x48.62	26.57x24.41x52.56	26.57x24.41x52.56
	Net/Gross weight	kg	48.4/57.7	48.4/57.7	58.8/69.4	58.8/69.4
		lb	106.70/127.21	106.70/127.21	129.63/153.00	129.63/153.00
Design pressure		MPa	4.2/1.5	4.2/1.5	4.2/1.5	4.2/1.5
Drainage water pipe dia.		mm	/	/	/	/
Refrigerant piping	Liquid side/ Gas side	mm(inch)	Φ6.35/Φ12.7(1/4"/1/2")	Φ9.52/Φ15.9(3/8"/5/8")	Φ9.52/Φ15.9(3/8"/5/8")	Φ9.52/Φ15.9(3/8"/5/8")
Controller			Wired Control	Wired Control	Wired control	Wired control
Operation temperature		°C	16~30	16~30	16~30	16~30
		°F	60~86	60~86	60~86	60~86
Room temperature	Cooling	°C	16~32	16~32	16~32	16~32
		°F	60~90	60~90	60~90	60~90
	Heating	°C	0~30	0~30	0~30	0~30
		°F	32~86	32~86	32~86	32~86
Qty/per 20' /40' /40'HQ			36/74/148	36/74/148	27/57/114	27/57/114

Notes:

1) Capacities are based on the following conditions:

Cooling: - Indoor Temperature 26.7°C(80°F) DB /19.4 °C(67°F) WB

-Outdoor Temperature 35 °C(95°F) DB /23.9 °C(75°F) WB

-Interconnecting Piping Length 7.5m

- Level Difference of Zero.

Heating: - Indoor Temperature 21.1°C(70°F) DB / 15.6°C(60°F) WB

-Outdoor Temperature 8.3°C(47°F) DB / 6.1°C(43°F) WB

- Interconnecting Piping Length 7.5 m

- Level Difference of Zero.

2) Capacities are net capacities.

3) Due to our policy of innovation some specifications may be changed without notification.

Indoor model		MSABB-09HRFN1-MX0W	MSABB-12HRFN1-MV0W	MSABE-18HRFN1-MW5W	MSABE-24HRFN1-MU0W	MSABF-30HRFN1-MR0W	MSABF-36HRFN1-MQ0W	
Power supply (Indoor)		V- Ph-Hz	208/230-1-60	208/230-1-60	208/230-1-60	208/230-1-60	208/230-1-60	
Indoor fan motor	Model		ZKFP-20-8-6-7	ZKFP-20-8-6-7	ZKFP-58-8-1-10	ZKFP-58-8-1-10	ZKFP-58-8-1-5	
	Input	W	50.0	50.0	58.0	58.0	58.0	
	RLA	A	0.1	0.1	0.25	0.4	0	
	LRA	A	/	/	/	/	/	
	Winding Resistance	Ω	/	/	/	/	/	
	Capacitor	uF	/	/	/	/	/	
	Speed(Hi/Med/Lo)	r/min	1080/850/650	1100/850/650	1000/800/700	1200/1000/750	1200/1050/950	1200/950/750
Indoor coil	a.Number of rows		2	2	2	2	2.0	
	b.Tube pitch(a)x row pitch(b)	mm	21x13.37	21x13.37	21x13.37	21x13.37	21x13.37	21x13.37
	c.Fin spacing	mm	1.3	1.3	1.3	1.3	1.2	1.2
	d.Fin type (code)		Hydrophilic aluminum	Hydrophilic aluminum	Hydrophilic aluminum	Hydrophilic aluminum	Hydrophilic aluminum	Hydrophilic aluminum
	e.Tube outside dia. and type	mm	Φ7 Inner groove tube	Φ7 Inner groove tube	Φ7 Inner groove tube	Φ7 Inner groove tube	Φ7 Inner groove tube	Φ7 Inner groove tube
	f.Coil length x height x width	mm	605x210x26.74+605x84x26.74	605x210x26.74+605x84x26.74	820x210x26.74+820x126x26.74	820x210x26.74+820x126x26.74	965x189x26.74+965x84x26.74+945x147x26.74	965x189x26.74+965x84x26.74+945x147x26.74
	g.Number of circuits		2	2	4	4	5	5
Indoor air flow (Hi/Med/Lo)		m3/h	450/350/240	520/360/250	800/600/500	1050/800/550	1350/1050/800	1245/880/680
		CFM	265/206/141	306/212/147	471/353/294	618/471/324	794/618/471	732/518/400
Indoor sound pressure level (Hi/Med/Lo)		dB(A)	37/30/21	37.5/30/21.5	43/35.5/29	47.5/42/32	51.5/47.5/44	56.5/54.5/40
Indoor unit	Dimension(W*D*H)	mm	802x189x297	802x189x297	1080x226x335	1080x226x335	1259x282x362	1259x282x362
		inch	31.57x7.44x11.69	31.57x7.44x11.69	42.52x8.90x13.19	42.52x8.90x13.19	49.57x11.10x14.25	49.57x11.10x14.25
	Packing (W*D*H)	mm	875x285x380	875x285x380	1155x415x320	1155x415x320	1340x450x385	1340x450x385
		inch	34.45x11.22x14.96	34.45x11.22x14.96	45.47x16.34x12.60	45.47x16.34x12.60	52.76x17.72x15.16	52.76x17.72x15.16
	Net/Gross weight	kg	8.6/10.9	8.6/10.9	13.4/17	13.7/17.2	17/22.9	18.3/23.9
	lb	18.96/24.03	18.96/24.03	29.54/37.48	30.20/37.92	37.48/50.49	40.34/52.69	
Design pressure		MPa	4.2/1.5	4.2/1.5	4.2/1.5	4.2/1.5	4.2/1.5	4.2/1.5
Refrigerant piping	Liquid side/ Gas side	mm(inch)	Φ6.35/Φ9.52(1/4"/3/8")	Φ6.35/Φ12.7(1/4"/1/2")	Φ6.35/Φ12.7(1/4"/1/2")	Φ9.52/Φ15.9(3/8"/5/8")	Φ9.52/Φ15.9(3/8"/5/8")	Φ9.52/Φ15.9(3/8"/5/8")
Controller			Remote Control	Remote Control	Remote Control	Remote control	Remote control	Remote control
Operation temperature		°C	17~30	17~30	17~30	17~30	17~30	17~30
		°F	63~86	63~86	63~86	63~86	63~86	63~86
Room temperature	Cooling	°C	17~32	17~32	17~32	17~32	17~32	17~32
		°F	63~90	63~90	63~90	63~90	63~90	63~90
	Heating	°C	0~30	0~30	0~30	0~30	0~30	0~30
		°F	32~86	32~86	32~86	32~86	32~86	32~86
Qty'per 20' /40' /40'HQ			300/630/720	300/630/720	195/400/464	195/400/464	130/264/300	130/264/300

Notes:

1) Capacities are based on the following conditions:

- Cooling: - Indoor Temperature 26.7°C(80°F) DB /19.4 °C(67°F) WB Heating: - Indoor Temperature 21.1°C(70°F) DB / 15.6°C(60°F) WB
 -Outdoor Temperature 35 °C(95°F) DB /23.9 °C(75°F) WB -Outdoor Temperature 8.3°C(47°F) DB / 6.1°C(43°F) WB
 -Interconnecting Piping Length 7.5m - Interconnecting Piping Length 7.5 m
 - Level Difference of Zero. - Level Difference of Zero.

2) Capacities are net capacities.

3) Due to our policy of innovation some specifications may be changed without notification.

Indoor model		MSAG11A-06HRFN1-MU0W	MSAG11B-09HRFN1-MX7W(GA)	MSAG11B-12HRFN1-MV0W(GA)	MSAG11D-18HRFN1-MT8W	
Power supply (Indoor)		V- Ph-Hz	208/230-1-60	208/230-1-60	208/230-1-60	208/230-1-60
Indoor fan motor	Model		ZKFP-13-8-4	ZKFP-13-8-4	ZKFP-13-8-4	ZKFP-58-8-1-5
	Input	W	18.2	18.2	18.2	58.0
	RLA	A	0.25	0.15	0.38	0.25
	LRA	A	/	/	/	/
	Winding Resistance	Ω	/	/	/	/
	Capacitor	uF	/	/	/	/
	Speed(Hi/Med/Lo)	r/min	1080/850/650	1100/850/650	1000/800/700	1200/1000/750
Indoor coil	a.Number of rows		2	2	2	2
	b.Tube pitch(a)x row pitch(b)	mm	21x13.37	21x13.37	21x13.37	21x13.37
	c.Fin spacing	mm	1.3	1.3	1.3	1.3
	d.Fin type (code)		Hydrophilic aluminum	Hydrophilic aluminum	Hydrophilic aluminum	Hydrophilic aluminum
	e.Tube outside dia.and type	mm	Φ7 Inner groove tube	Φ7 Inner groove tube	Φ7 Inner groove tube	Φ7 Inner groove tube
	f.Coil length x height x width	mm	525x84x13.37+ 525x105x26.74+ 525x105x26.74	605x210x26.74+ 605x105x26.74	605x210x26.74+ 605x105x26.74	820x210x26.74+ 820x126x26.74
	g.Number of circuits		2	2	2	4
Indoor air flow (Hi/Med/Lo)		m3/h	420/300/240	495/330/260	495/330/260	902/780/650
		CFM	247.06/176.47/141.18	291.18/194.12/152.94	291.18/194.12/152.94	530.59/458.82/382.35
Indoor sound pressure level (Hi/Med/Lo)		dB(A)	38.5/33/20.5	40/34/23.5	42/36/25	45.5/41/24.5
Indoor unit	Dimension(W*D*H)	mm	729x200x292	802x200x295	802x200x295	1082x234x337
		inch	28.70x7.87x11.50	31.57x7.87x11.61	31.57x7.87x11.61	42.60x9.21x13.27
	Packing (W*D*H)	mm	790x270x375	875x285x380	875x285x380	1155x415x315
		inch	31.10x10.63x14.76	34.45x11.22x14.96	34.45x11.22x14.96	45.47x16.34x12.40
	Net/Gross weight	kg	8.0/10.2	8.6/11	8.5/11	13.4/17
		lb	17.64/22.49	18.96/24.25	18.74/24.25	29.54/37.48
Design pressure		MPa	4.2/1.5	4.2/1.5	4.2/1.5	4.2/1.5
Refrigerant piping	Liquid side/ Gas side	mm(inch)	Φ6.35/Φ9.52(1/4"/3/8")	Φ6.35/Φ9.52(1/4"/3/8")	Φ6.35/Φ12.7(1/4"/1/2")	Φ6.35/Φ12.7(1/4"/1/2")
Controller			Remote Control	Remote Control	Remote Control	Remote control
Operation temperature		°C	16~30	16~30	16~30	16~30
		°F	60~86	60~86	60~86	60~86
Room temperature	Cooling	°C	16~32	16~32	16~32	16~32
		°F	60~90	60~90	60~90	60~90
	Heating	°C	0~30	0~30	0~30	0~30
		°F	32~86	32~86	32~86	32~86
Qty/per 20' /40' /40'HQ			370/760/860	300/630/720	300/630/720	195/400/464

Notes:

1) Capacities are based on the following conditions:

- Cooling: - Indoor Temperature 26.7°C(80°F) DB /19.4 °C(67°F) WB Heating: - Indoor Temperature 21.1°C(70°F) DB / 15.6°C(60°F) WB
 -Outdoor Temperature 35 °C(95°F) DB /23.9 °C(75°F) WB -Outdoor Temperature 8.3°C(47°F) DB / 6.1°C(43°F) WB
 -Interconnecting Piping Length 7.5m - Interconnecting Piping Length 7.5 m
 - Level Difference of Zero. - Level Difference of Zero.

2) Capacities are net capacities.

3) Due to our policy of innovation some specifications may be changed without notification.

Indoor model			MSAG11D-23HRFN1-MU0W	MSAGF-30HRFN1-MT0W	MSAGF-36HRFNX-MR0W
Power supply (Indoor)		V- Ph-Hz	208/230-1-60	208/230-1-60	208/230-1-60
Indoor fan motor	Model		ZKFP-58-8-1-5	ZKFP-58-8-1-5	ZKFP-58-8-1-5
	Input	W	58	58	58
	RLA	A	0.38	0.5	0.5
	LRA	A	/	/	/
	Winding Resistance	Ω	/	/	/
	Capacitor	uF	/	/	/
	Speed(Hi/Med/Lo)	r/min	1200/1080/600	1200/1050/950	1200/960/600
Indoor coil	a.Number of rows		2	3	3
	b.Tube pitch(a)x row pitch(b)	mm	21x13.37	21x13.37	21x13.37
	c.Fin spacing	mm	1.3	1.3	1.3
	d.Fin type (code)		Hydrophilic aluminum	Hydrophilic aluminum	Hydrophilic aluminum
	e.Tube outside dia.and type	mm	Φ7 Inner groove tube	Φ7 Inner groove tube	Φ7 Inner groove tube
	f.Coil length x height x width	mm	820x210x26.74+ 820x126x26.74	965x126x40.11+ 965x126x40.11+ 945x126x40.11	965x126x40.11+ 965x126x40.11+ 945x126x40.11
	g.Number of circuits		4	7	7
Indoor air flow (Hi/Med/Lo)		m ³ /h	1022/780/650	1193/911/646	1110/760/560
		CFM	601/459/382	702/536/380	653/447/329
Indoor sound pressure level (Hi/Med/Lo)		dB(A)	48/40/28	49.5/43.5/39.5	54/45/40
Indoor unit	Dimension(W*D*H)	mm	1082x234x337	1259x283x362	1259x283x362
		inch	42.60x9.21x13.27	49.57x11.14x14.25	49.57x11.14x14.25
	Packing (W*D*H)	mm	1155x415x315	1340x450x385	1340x450x385
		inch	45.47x16.34x12.40	52.76x17.72x15.16	52.76x17.72x15.16
	Net/Gross weight	kg	13.6/17.3	19.5/25.2	19.4/25.2
		lb	29.98/38.14	42.99/55.56	42.77/55.56
Design pressure		MPa	4.2/1.5	4.2/1.5	4.2/1.5
Refrigerant piping	Liquid side/ Gas side	mm(inch)	Φ9.52/Φ15.9(3/8"/5/8")	Φ9.52/Φ15.9(3/8"/5/8")	Φ9.52/Φ15.9(3/8"/5/8")
Controller			Remote Control	Remote Control	Remote Control
Operation temperature		°C	16~30	16~30	16~30
		°F	60~86	60~86	60~86
Room temperature	Cooling	°C	16~32	16~32	16~32
		°F	60~90	60~90	60~90
	Heating	°C	0~30	0~30	0~30
		°F	32~86	32~86	32~86
Qty'per 20' /40' /40'HQ			195/400/464	130/264/300	130/264/300

Notes:

1) Capacities are based on the following conditions:

Cooling: - Indoor Temperature 26.7°C(80°F) DB /19.4 °C(67°F) WB

-Outdoor Temperature 35 °C(95°F) DB /23.9 °C(75°F) WB

-Interconnecting Piping Length 7.5m

- Level Difference of Zero.

Heating: - Indoor Temperature 21.1°C(70°F) DB / 15.6°C(60°F) WB

-Outdoor Temperature 8.3°C(47°F) DB / 6.1°C(43°F) WB

- Interconnecting Piping Length 7.5 m

- Level Difference of Zero.

2) Capacities are net capacities.

3) Due to our policy of innovation some specifications may be changed without notification.

Indoor model		MSEPB-06HRFN1-MY5W	MSEPB-09HRFN1-MY5W(GA)	MSEPB-12HRFN1-MW5W(GA)	MSEPC-18HRFN1-MU0W	
Power supply (Indoor)		V- Ph-Hz	208/230-1-60	208/230-1-60	208/230-1-60	208/230-1-60
Indoor fan motor	Model		ZKFP-20-8-6-7	ZKFP-20-8-6-7	ZKFP-20-8-6-7	ZKFP-30-8-3-10
	Input	W	50.0	50.0	50.0	36.0
	RLA	A	0.41	0.25	0.25	0.4
	LRA	A	/	/	/	/
	Winding Resistance	Ω	/	/	/	/
	Capacitor	uF	/	/	/	/
	Speed(Hi/Med/Lo)	r/min	1050/930/870	1100/850/700	1050/930/870	1240/1024/916
Indoor coil	a.Number of rows		2	2	2	2
	b.Tube pitch(a)x row pitch(b)	mm	21x13.37	21x13.37	21x13.37	21x13.37
	c.Fin spacing	mm	1.3	1.3	1.3	1.3
	d.Fin type (code)		Hydrophilic aluminum	Hydrophilic aluminum	Hydrophilic aluminum	Hydrophilic aluminum
	e.Tube outside dia.and type	mm	Φ7 Inner groove tube	Φ7 Inner groove tube	Φ7 Inner groove tube	Φ7 Inner groove tube
	f.Coil length x height x width	mm	635x84x26.74+ 635x126x26.74+ 635x105x26.74	635x84x26.74+ 635x126x26.74+ 635x105x26.74	635x84x26.74+ 635x126x26.74+ 635x105x26.74	760x84x26.74+ 760x126x26.74+ 760x126x26.74
	g.Number of circuits		3	3	3	4
Indoor air flow (Hi/Med/Lo)		m3/h	540/370/285	570/390/300	570/390/300	890/640/520
		CFM	318/218/168	335/229/176	335/229/176	524/376/306
Indoor sound pressure level (Hi/Med/Lo)		dB(A)	36/32/23	38/33.5/23.5	38/33.5/23.5	46/42/24
Indoor unit	Dimension(W*D*H)	mm	795x225x295	795x225x295	795x225x295	965x239x319
		inch	31.30x8.86x11.61	31.30x8.86x11.61	31.30x8.86x11.61	37.99x9.41x12.56
	Packing (W*D*H)	mm	870x370x305	870x370x305	870x370x305	1045x400x325
		inch	34.25x14.57x12.01	34.25x14.57x12.01	34.25x14.57x12.01	41.14x15.75x12.80
	Net/Gross weight	kg	10.3/13.1	10.3/13.1	10.4/13.1	12.3/16.2
		lb	22.71/28.88	22.71/28.88	22.93/28.88	27.12/35.71
Design pressure		MPa	4.2/1.5	4.2/1.5	4.2/1.5	4.2/1.5
Refrigerant piping	Liquid side/ Gas side	mm(inch)	Φ6.35/Φ9.52(1/4"/3/8")	Φ6.35/Φ9.52(1/4"/3/8")	Φ6.35/Φ12.7(1/4"/1/2")	Φ6.35/Φ12.7(1/4"/1/2")
Controller			Remote Control	Remote Control	Remote Control	Remote control
Operation temperature		°C	16~30	16~30	16~30	16~30
		°F	60~86	60~86	60~86	60~86
Room temperature	Cooling	°C	16~32	16~32	16~32	16~32
		°F	60~90	60~90	60~90	60~90
	Heating	°C	0~30	0~30	0~30	0~30
		°F	32~86	32~86	32~86	32~86
Qty/per 20' /40' /40'HQ			370/760/860	300/630/720	300/630/720	195/400/464

Notes:

1) Capacities are based on the following conditions:

- Cooling: - Indoor Temperature 26.7°C(80°F) DB /19.4 °C(67°F) WB Heating: - Indoor Temperature 21.1°C(70°F) DB / 15.6°C(60°F) WB
 -Outdoor Temperature 35 °C(95°F) DB /23.9 °C(75°F) WB -Outdoor Temperature 8.3°C(47°F) DB / 6.1°C(43°F) WB
 -Interconnecting Piping Length 7.5m - Interconnecting Piping Length 7.5 m
 - Level Difference of Zero. - Level Difference of Zero.

2) Capacities are net capacities.

3) Due to our policy of innovation some specifications may be changed without notification.

Indoor model			MSEPD-24HRFN1-MU0W	MSEPD-30HRFN1-MS8W	MSEPD-36HRFN1-MQ0W
Power supply (Indoor)		V- Ph-Hz	208/230-1-60	208/230-1-60	208/230-1-60
Indoor fan motor	Model		ZKFP-58-8-1-5	ZKFP-58-8-1-5	ZKFP-58-8-1-5
	Input	W	58	58	58
	RLA	A	0.5	0.5	0.5
	LRA	A	/	/	/
	Winding Resistance	Ω	/	/	/
	Capacitor	uF	/	/	/
	Speed(Hi/Med/Lo)	r/min	1000/850/700	1050/880/630	1050/880/630
Indoor coil	a.Number of rows		3	3	3
	b.Tube pitch(a)x row pitch(b)	mm	21x13.37	21x13.37	21x13.37
	c.Fin spacing	mm	1.3	1.3	1.3
	d.Fin type (code)		Hydrophilic aluminum	Hydrophilic aluminum	Hydrophilic aluminum
	e.Tube outside dia.and type	mm	Φ7 Inner groove tube	Φ7 Inner groove tube	Φ7 Inner groove tube
	f.Coil length x height x width	mm	885x126x40.11+ 885x126x40.11	885x126x40.11+ 885x126x40.11	885x126x40.11+ 885x126x40.11
	g.Number of circuits		7	7	7
Indoor air flow (Hi/Med/Lo)		m ³ /h	1039/704/542	1099/859/650	1087/860/650
		CFM	611/414/319	646/505/382	639/506/382
Indoor sound pressure level (Hi/Med/Lo)		dB(A)	46/39/34	46/40.5/33	47.5/42/35.5
Indoor unit	Dimension(W*D*H)	mm	1140x275x370	1140x275x370	1140x275x370
		inch	44.88x10.83x14.57	44.88x10.83x14.57	44.88x10.83x14.57
	Packing (W*D*H)	mm	1230x455x355	1230x455x355	1230x455x355
		inch	48.43x17.91x13.98	48.43x17.91x13.98	48.43x17.91x13.98
	Net/Gross weight	kg	19.8/24.9	19.8/24.9	19.8/24.9
		lb	43.65/54.89	43.65/54.89	43.65/54.89
Design pressure		MPa	4.2/1.5	4.2/1.5	4.2/1.5
Refrigerant piping	Liquid side/ Gas side	mm(inch)	Φ9.52/Φ15.9(3/8"/5/8")	Φ9.52/Φ15.9(3/8"/5/8")	Φ9.52/Φ15.9(3/8"/5/8")
Controller			Remote Control	Remote Control	Remote Control
Operation temperature		°C	16~30	16~30	16~30
		°F	60~86	60~86	60~86
Room temperature	Cooling	°C	16~32	16~32	16~32
		°F	60~90	60~90	60~90
	Heating	°C	0~30	0~30	0~30
		°F	32~86	32~86	32~86
Qty'per 20' /40' /40'HQ			143/297/348	143/297/348	143/297/348

Notes:

1) Capacities are based on the following conditions:

Cooling: - Indoor Temperature 26.7°C(80°F) DB /19.4 °C(67°F) WB

-Outdoor Temperature 35 °C(95°F) DB /23.9 °C(75°F) WB

-Interconnecting Piping Length 7.5m

- Level Difference of Zero.

Heating: - Indoor Temperature 21.1°C(70°F) DB / 15.6°C(60°F) WB

-Outdoor Temperature 8.3°C(47°F) DB / 6.1°C(43°F) WB

- Interconnecting Piping Length 7.5 m

- Level Difference of Zero.

2) Capacities are net capacities.

3) Due to our policy of innovation some specifications may be changed without notification.

Outdoor model		M2OA-18HFN1-M	M3OJ-27HFN1-M	M4OG-36HFN1-M	M5OG-48HFN1-M	
Power Supply (Outdoor)	V-Ph-Hz	208/230-1-60	208/230-1-60	208/230-1-60	208/230-1-60	
Max. input consumption	W	3450	4100	4800	6400	
Max. current	A	15	19	21.0	32	
Min. Circuit ampacity	A	18	24.5	25.0	40	
Max.Fuse	A	25	30	40	60	
Compressor	Model	KTN150D30UFZA	KTM240D43UKT	KTF310D43UMT	ATQ360D1UMU	
	Type	Twin-ROTARY	Twin-ROTARY	ROTARY	ROTARY	
	Brand	GMCC	GMCC	GMCC	GMCC	
	Capacity	W	4730	7600	10010	11200
	Input	W	1250	2045	2765	3040
	Rated current(RLA)	A	11	14	18.0	24
	Locked rotor Amp(LRA)	A	/	/	/	/
	Thermal protector	A	/	/	INT01L-4639	/
	Thermal protector position		NA	NA	EXTERNAL	NA
	Capacitor	µF	/	/	/	/
Refrigerant oil	ml	ESTER OIL VG74 450	ESTER OIL VG74 620	VG74/1000	VG74/1400	
Outdoor fan motor	Model	ZKFN-80-8-3	ZKFN-120-8-2	ZKFN-120-8-2	ZKFN-85-8-22-5	
	Qty	1	1	1	2	
	Input	W	88	150.0	150.0	126.0
	RLA	A	1	1.7	1.0	2.5
	LRA	A	/	/	/	/
	Capacitor	uF	/	/	/	/
	Speed	r/min	750/600/500	1050/900/850	1000/900/750	900/850/800/750
Outdoor coil	Number of rows	2	2	2.6	2	
	Tube pitch(a)x row pitch(b)	mm	25.4x22	25.4x22	25.4x22	25.4x22
	Fin spacing	mm	1.3	1.4	1.5	1.2
	Fin type (code)		Hydrophilic aluminum	Hydrophilic aluminum	Hydrophilic aluminum	Hydrophilic aluminum
	Tube outside dia.and type	mm	Φ7,Inner groove tube	Φ7,Inner groove tube	Φ9.52,Inner groove tube	Φ7,Inner groove tube
	Coil length x height x width	mm	900*609*22+ 865*609*22	1005x756x13.37+ 985x756x13.37	995x762x22+ 960x762x22+ 580x762x22	980x630x44
	Number of circuits		6	6	6	10
Outdoor air flow	m ³ /h	3000	3620	3650	7650	
	CFM	1765	2129	2147	4500	
Outdoor sound pressure level	dB(A)	58.5	61	63	64.0	
Throttle type		Capillary+EXV	Capillary+EXV	Capillary+EXV	EXV	
Outdoor unit	Dimension(W*D*H)	mm	890x342x673	946x410x810	946x410x810	952x415x1333
		inch	35.04x13.46x26.50	37.24x16.14x31.89	37.24x16.14x31.89	37.48x16.34x52.48
	Packing (W*D*H)	mm	1030x438x750	1090x500x885	1090x500x885	1095x495x1480
		inch	40.55x17.24x29.53	42.91x19.69x34.84	42.91x19.69x34.84	43.11x19.49x58.27
	Net/Gross weight	kg	45.5/49.3	63.4/68.3	76.7/82.3	102.3/116.4
lb		100.31/108.69	139.77/150.57	169.09/181.44	225.53/256.62	
Refrigerant type	Type	-	R410A	R410A	R410A	
	Charged quantity	ozs	65.26	91.7	134.04	162
Design pressure	MPa	4.2/1.5	4.2/1.5	4.2/1.5	4.2/1.5	
Refrigerant piping	Liquid side/ Gas side	mm(inch)	2 x Φ6.35/Φ9.52(1/4"/3/8")	3 x Φ6.35/Φ9.52(1/4"/3/8")	4 x Φ6.35/3x Φ9.52+1xΦ12.7 (4x1/4"/3x3/8"+1x1/2")	5 x Φ6.35/3x Φ9.52+2xΦ12.7(5 x1/4"/3x3/8"+2x1/2")
	Max. length for all rooms	m	40	60	80	80
		ft	131.23	196.85	262.46	262.46
	Max. length for one indoor unit	m	25	30	35	35
		ft	82	98.42	114.83	114.83
	Max. height difference between indoor and outdoor unit	m	15	15	15	15
		ft	49.21	49.21	49.21	49.21
Max. height difference between indoor units	m	10	10	10	10	
	ft	33	33	33	33	

Ambient temperature	Cooling	°C	-25~50	-25~50	-25~50	-15~50
		°F	-13~122	-13~122	-13~122	5~122
	Heating	°C	-25~24	-25~24	-25~24	-15~24
		°F	-13~75.2	-13~75.2	-13~75.2	5~75.2
Qty'per 20' /40' /40'HQ			84/171/171	44/96/138	44/96/138	22/48/48

Notes:

1) Capacities are based on the following conditions:

Cooling: - Indoor Temperature 26.7°C(80°F) DB /19.4 °C(67°F) WB
 -Outdoor Temperature 35 °C(95°F) DB /23.9 °C(75°F) WB
 -Interconnecting Piping Length 7.5m
 - Level Difference of Zero.

Heating: - Indoor Temperature 21.1°C(70°F) DB / 15.6°C(60°F) WB
 -Outdoor Temperature 8.3°C(47°F) DB / 6.1°C(43°F) WB
 - Interconnecting Piping Length 7.5 m
 - Level Difference of Zero.

2) Capacities are net capacities.

3) Due to our policy of innovation some specifications may be changed without notification.

6. Indoor Unit Combination

Multi DC Outdoor Unit		Nominal capacity	Suggested Combination
			Two units
1 drive 2	M20A-18HFN1-M	5.2kW	6+6
			6+9
			6+12
			9+9
			9+12
			12+12

Multi DC Outdoor Unit		Nominal capacity	Suggested Combination		
			Two units	Three units	
1 drive 3	M30J-27HFN1-M	7.8kW	6+12	6+6+6	6+12+18
			6+18	6+6+9	9+9+9
			9+9	6+6+12	9+9+12
			9+12	6+6+18	9+9+18
			9+18	6+9+9	9+12+12
			12+12	6+9+12	12+12+12
			12+18	6+9+18	
			18+18	6+12+12	

Multi DC Outdoor Unit		Nominal capacity	Suggested Combination						
			Two units	Three units		Four units			
1 drive 4	M40G-36HFN1-M	10.5kW	6+18	6+6+12	6+18+24	12+12+18	6+6+6+6	6+6+12+18	9+9+9+9
			6+24	6+6+18	9+9+9	12+12+24	6+6+6+9	6+6+12+24	9+9+9+12
			9+18	6+6+24	9+9+12	12+18+18	6+6+6+12	6+9+9+9	9+9+9+18
			9+24	6+9+12	9+9+18		6+6+6+18	6+9+9+12	9+9+12+12
			12+12	6+9+18	9+9+24		6+6+6+24	6+9+9+18	9+9+12+18
			12+18	6+9+24	9+12+12		6+6+9+9	6+9+9+24	9+12+12+12
			12+24	6+12+12	9+12+18		6+6+9+12	6+9+12+12	12+12+12+12
			18+18	6+12+18	9+12+24		6+6+9+18	6+9+12+18	
			18+24	6+12+24	9+18+18		6+6+9+24	6+12+12+12	
			24+24	6+18+18	12+12+12		6+6+12+12	6+12+12+18	

Multi DC Outdoor Unit		Nominal capacity	Suggested Combination			
			Two units	Three units		
1 drive 5	M50G-48HFN1-M	14kW	9+24	6+6+24	6+24+24	9+18+36
			9+30	6+6+30	6+24+30	9+24+24
			9+36	6+6+36	9+9+18	9+24+30
			12+24	6+9+24	9+9+24	12+12+12
			12+30	6+9+30	9+9+30	12+12+18
			12+36	6+9+36	9+9+36	12+12+24
			18+18	6+12+18	9+12+12	12+12+30
			18+24	6+12+24	9+12+18	12+12+36
			18+30	6+12+30	9+12+24	12+18+18
			18+36	6+12+36	9+12+30	12+18+24
			24+30	6+18+18	9+12+36	12+18+30
			24+36	6+18+24	9+18+18	12+24+24
			30+30	6+18+30	9+18+24	18+18+18
				6+18+36	9+18+30	18+18+24

Four Units					
6+6+6+18	6+6+12+24	6+9+9+30	6+12+12+12	9+9+9+30	9+12+12+24
6+6+6+24	6+6+12+30	6+9+9+36	6+12+12+18	9+9+9+36	9+12+12+30
6+6+6+30	6+6+12+36	6+9+12+12	6+12+12+24	9+9+12+12	9+12+18+18
6+6+6+36	6+6+18+18	6+9+12+18	6+12+12+30	9+9+12+18	9+12+18+24
6+6+9+18	6+6+18+24	6+9+12+24	6+12+18+18	9+9+12+24	12+12+12+12
6+6+9+24	6+6+18+30	6+9+12+30	6+12+18+24	9+9+12+30	12+12+12+18
6+6+9+30	6+6+24+24	6+9+12+36	9+9+9+9	9+9+18+18	12+12+12+24
6+6+9+36	6+9+9+12	6+9+18+18	9+9+9+12	9+9+18+24	12+12+18+18
6+6+12+12	6+9+9+18	6+9+18+24	9+9+9+18	9+12+12+12	
6+6+12+18	6+9+9+24	6+9+18+30	9+9+9+24	9+12+12+18	

Five Units					
6+6+6+6+9	6+6+6+9+30	6+6+9+9+18	6+6+12+12+18	6+9+9+12+24	9+9+9+9+24
6+6+6+6+12	6+6+6+9+36	6+6+9+9+24	6+6+12+12+24	6+9+9+18+18	9+9+9+12+12
6+6+6+6+18	6+6+6+12+12	6+6+9+9+30	6+6+12+18+18	6+9+12+12+12	9+9+9+12+18
6+6+6+6+24	6+6+6+12+18	6+6+9+12+12	6+9+9+9+9	6+9+12+12+18	9+9+9+12+24
6+6+6+6+30	6+6+6+12+24	6+6+9+12+18	6+9+9+9+12	6+9+12+12+24	9+9+12+12+12
6+6+6+6+36	6+6+6+12+30	6+6+9+12+24	6+9+9+9+18	6+12+12+12+12	9+9+12+12+18
6+6+6+9+9	6+6+6+18+18	6+6+9+12+30	6+9+9+9+24	6+12+12+12+18	9+12+12+12+12
6+6+6+9+12	6+6+6+18+24	6+6+9+18+18	6+9+9+9+30	9+9+9+9+9	12+12+12+12+12
6+6+6+9+18	6+6+9+9+9	6+6+9+18+24	6+9+9+12+12	9+9+9+9+12	
6+6+6+9+24	6+6+9+9+12	6+6+12+12+12	6+9+9+12+18	9+9+9+9+18	

7. Dimensional Drawings

7.1 Indoor Unit

A6 Duct type

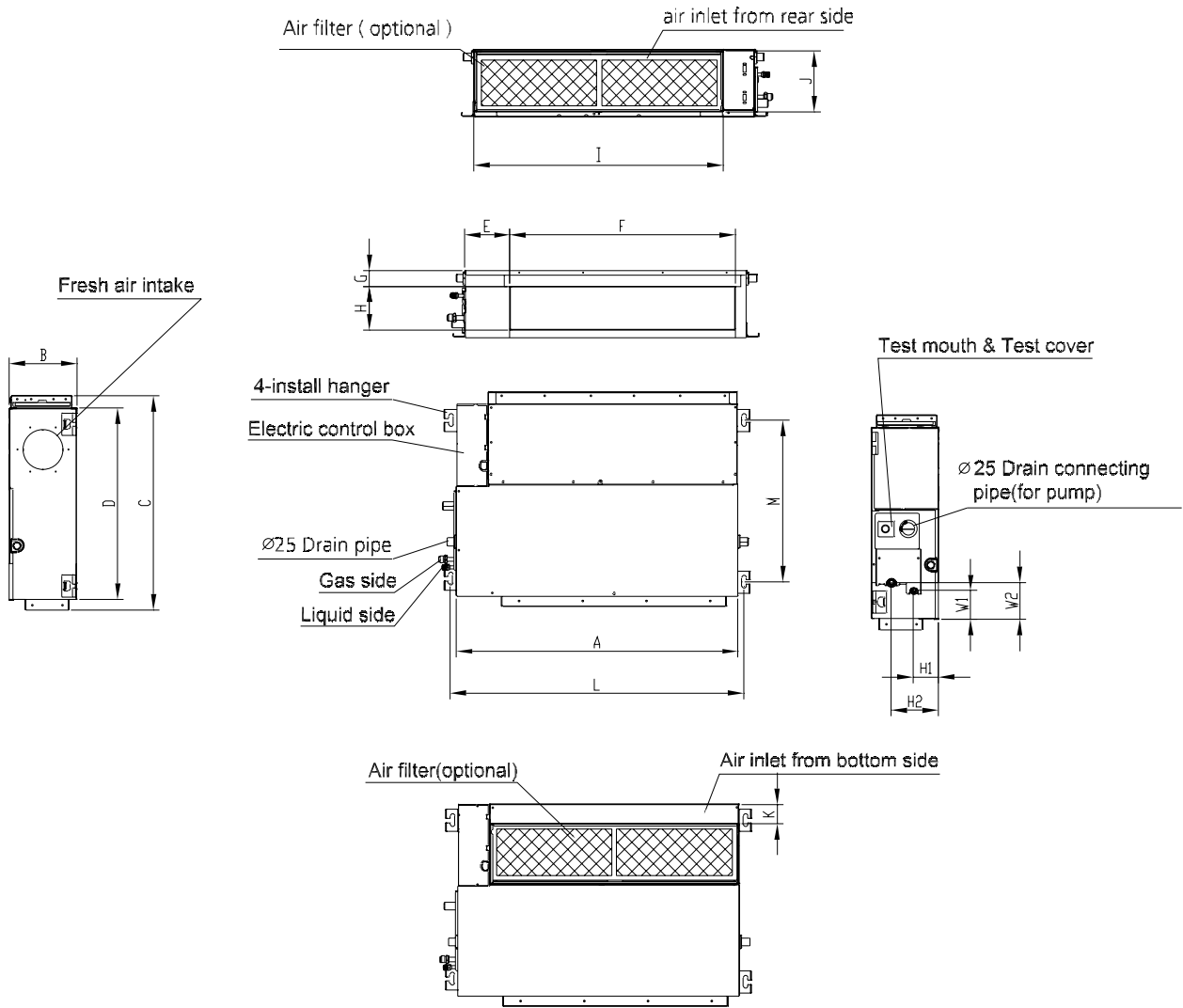

Capacity (kBtu/h)	unit	A	B	C	D	E	F	G	H	I	J	K	L	M	H1	H2	W1	W2
9/12	mm	700	200	506	450	137	537	30	152	599	186	50	741	360	84	140	84	84
	inch	27.56	7.87	19.92	17.72	5.39	21.14	1.18	5.98	23.58	7.32	1.97	29.17	14.17	3.31	5.51	3.31	3.31
18	mm	880	210	674	600	140	706	50	136	782	190	40	920	508	78	148	88	112
	inch	34.65	8.27	26.54	23.62	5.51	27.8	1.97	5.35	30.79	7.48	1.57	36.22	20	3.07	5.83	3.46	4.41
24	mm	1100	249	774	700	140	926	50	175	1001	228	5	1140	598	80	150	130	155
	inch	43.31	9.8	30.47	27.56	5.51	36.46	1.97	6.89	39.41	8.98	0.2	44.88	23.54	3.15	5.91	5.12	6.1

Compact Cassette type

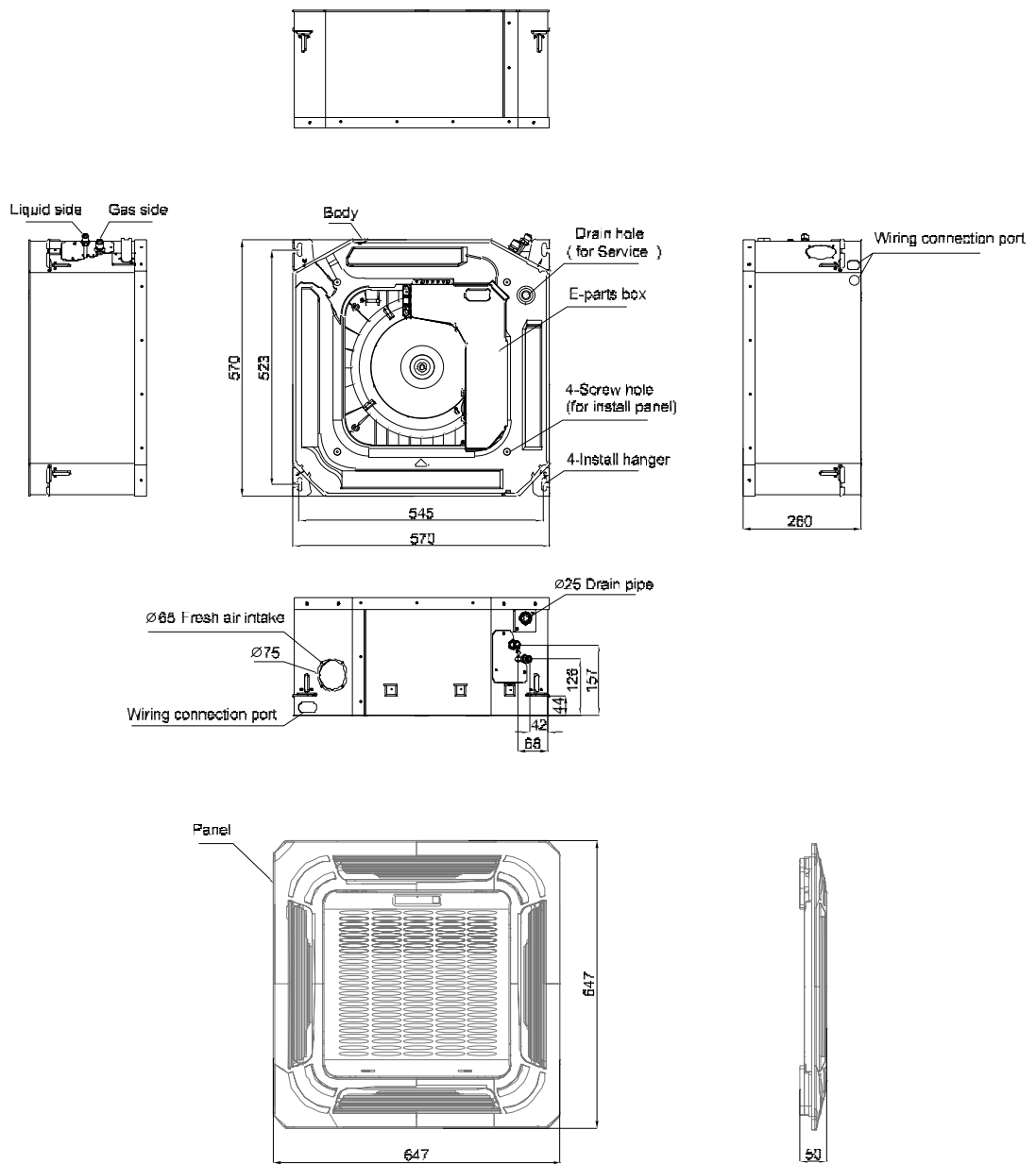

Super Slim Cassette

Specifications

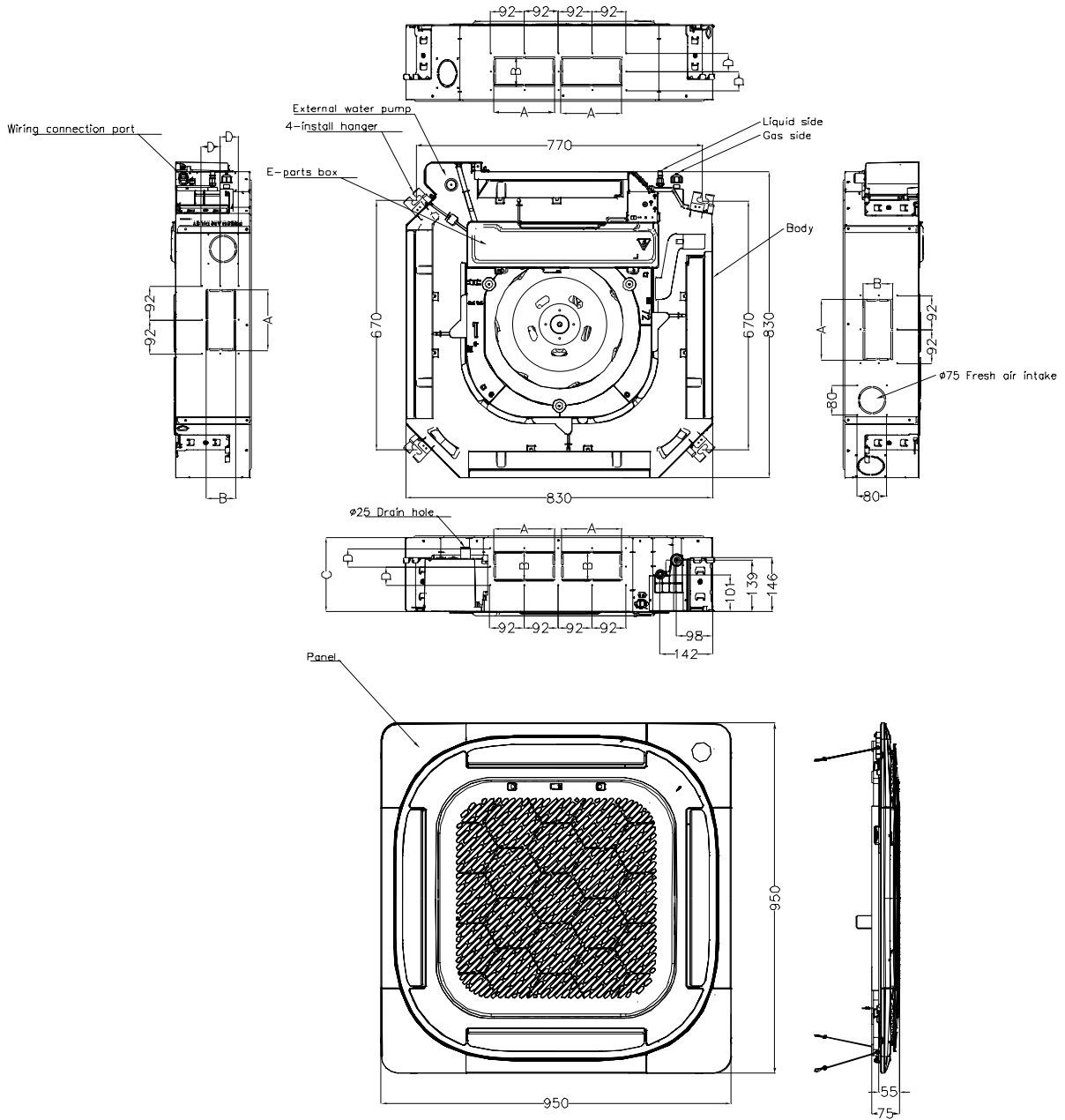

Model (KBtu/h)	Unit	A	B	C	D
24	mm	165	80	205	50
	inch	6.50	3.15	8.07	1.97

Floor Ceiling type

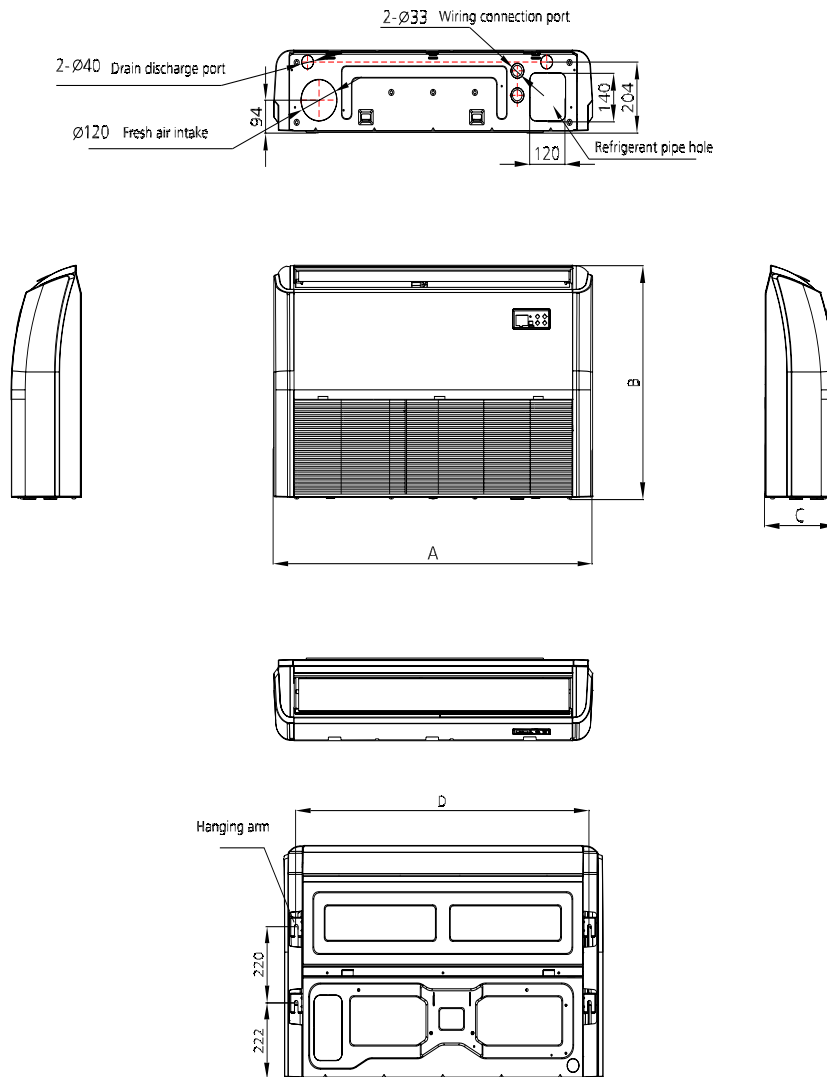

Model(KBtu/h)	Unit	A	B	C	D
18-24	mm	1068	675	235	983
	inch	42.05	26.57	9.25	38.7

Air handler Type

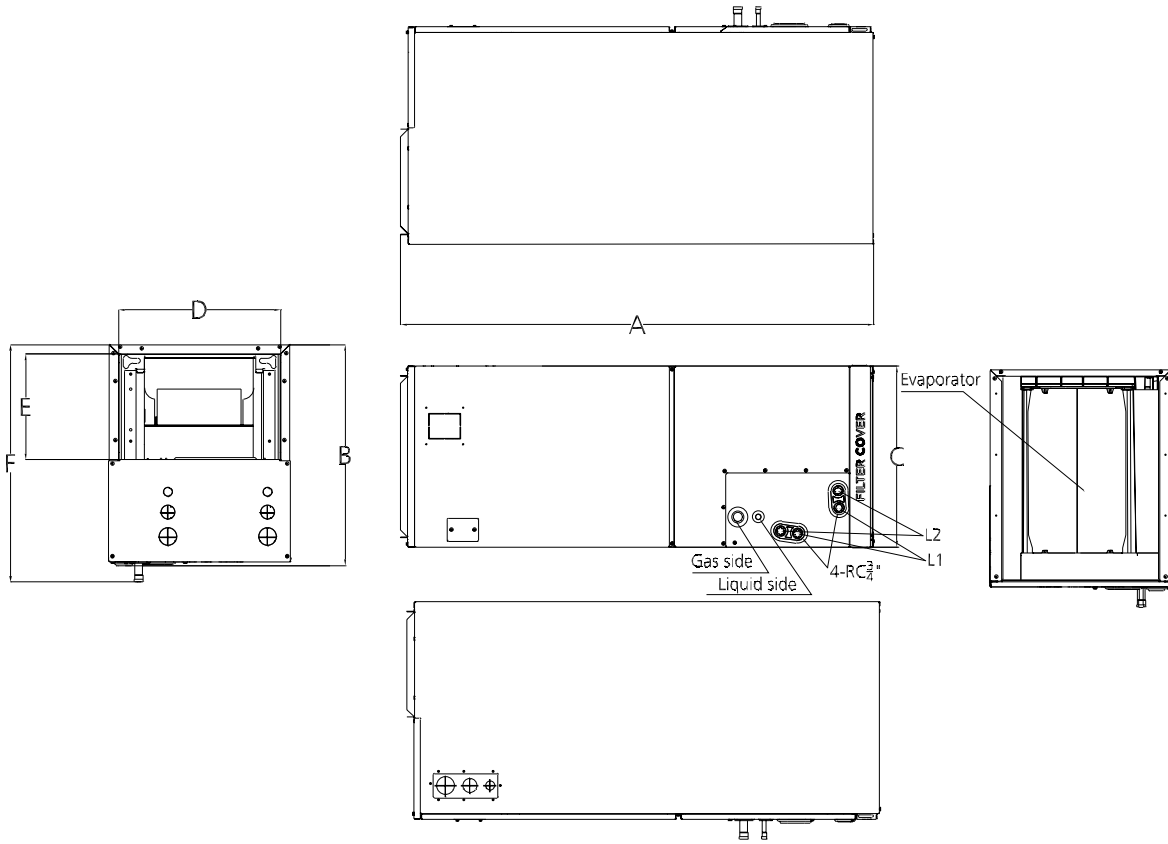

Model	Unit	Dimensions(mm)						Drain hole	
		A	B	C	D	E	F	L1	L2
18k~24k	mm	1143	534	445	400	260	585	Main drain	Overflow drain
	inch	45	21	17-1/2	15-3/4	10-1/4	23		
30k-36k	mm	1245	534	534	490	260	585		
	inch	49	21	21	19-5/16	10-1/4	23		

Wall mounted type-Aurora

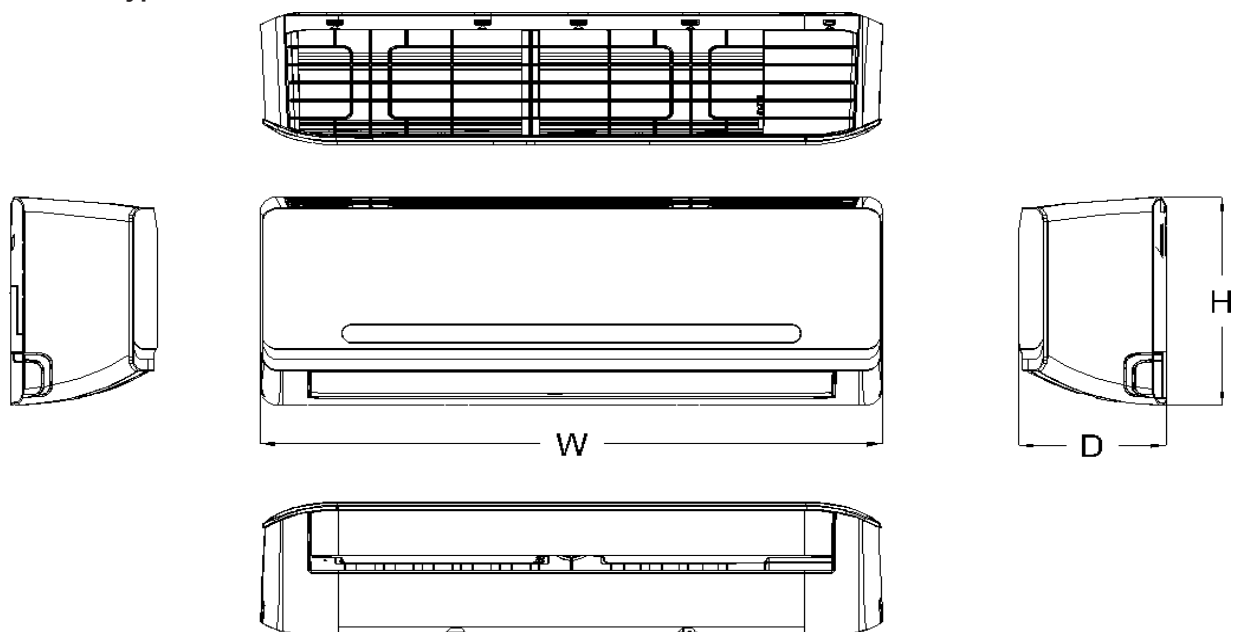

Model(kBtu/h)	Unit	W	D	H
9~12	mm	802	189	297
	inch	31.57	7.44	11.69
18~24	mm	1080	226	335
	inch	42.52	8.90	13.19
30~36	mm	1259	282	362
	inch	49.57	11.10	14.25

Wall mounted type-INFINI

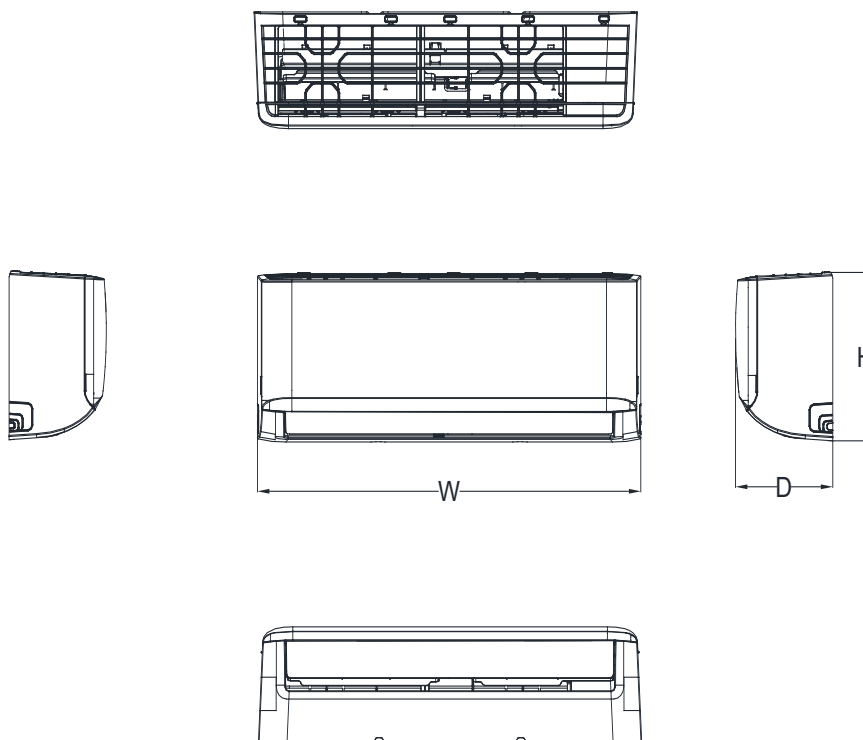

Model(kBtu/h)	W(mm/inch)	D(mm/inch)	H(mm/inch)
6	729/28.7	200/7.87	292/11.5
9~12	802/31.57	200/7.87	295/11.61
18~24	1082/42.6	234/9.21	337/13.27
30~36	1259/49.57	283/11.14	362/14.25

Wall mounted type-All Easy Pro

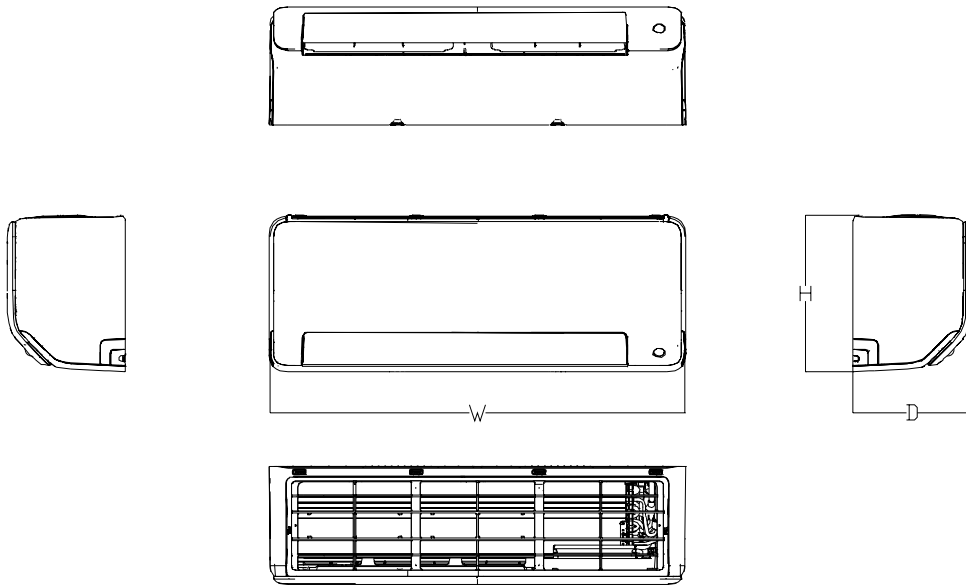

Model(kBtu/h)	W(mm/inch)	D(mm/inch)	H(mm/inch)
6k~12k	795/31.3	225/8.86	295/11.61
18k	965/38	239/9.41	319/12.56
24k~36k	1140/44.88	275/10.83	370/14.57

7.2 Outdoor Unit

M20A-18HFN1-M

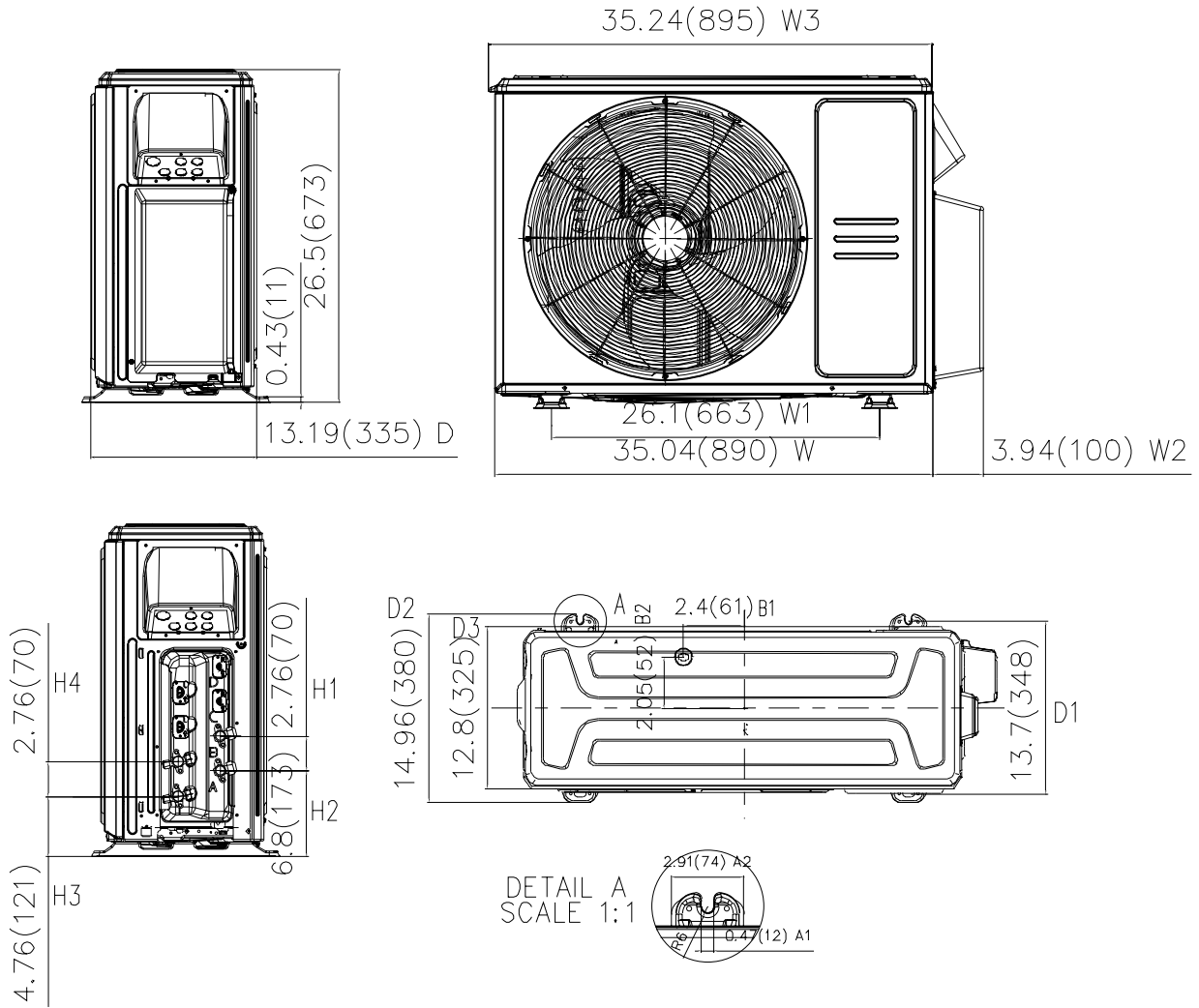

M30J-27HFN1-M, M40G-36HFN1-M

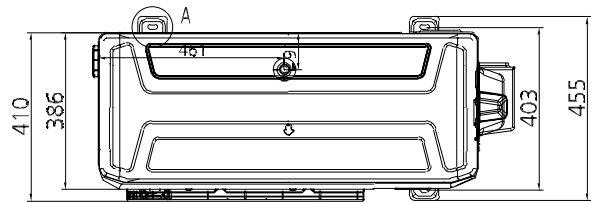
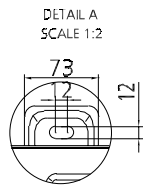
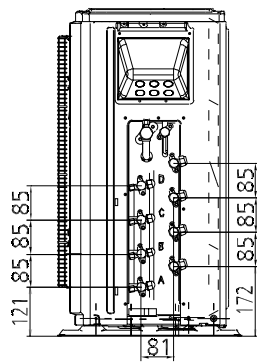
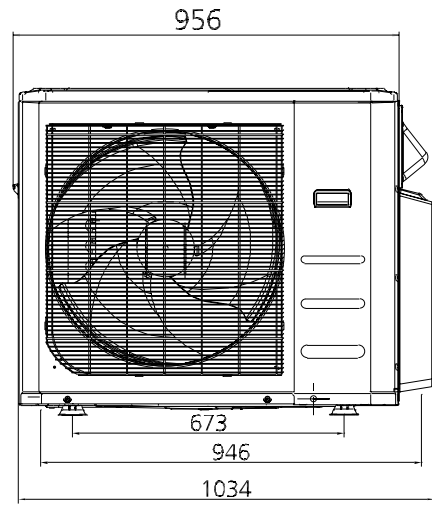
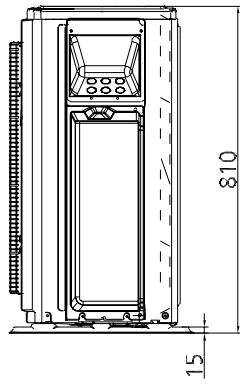
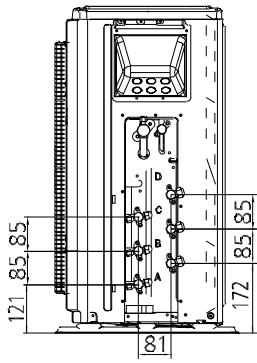

M50G-48HFN1-M

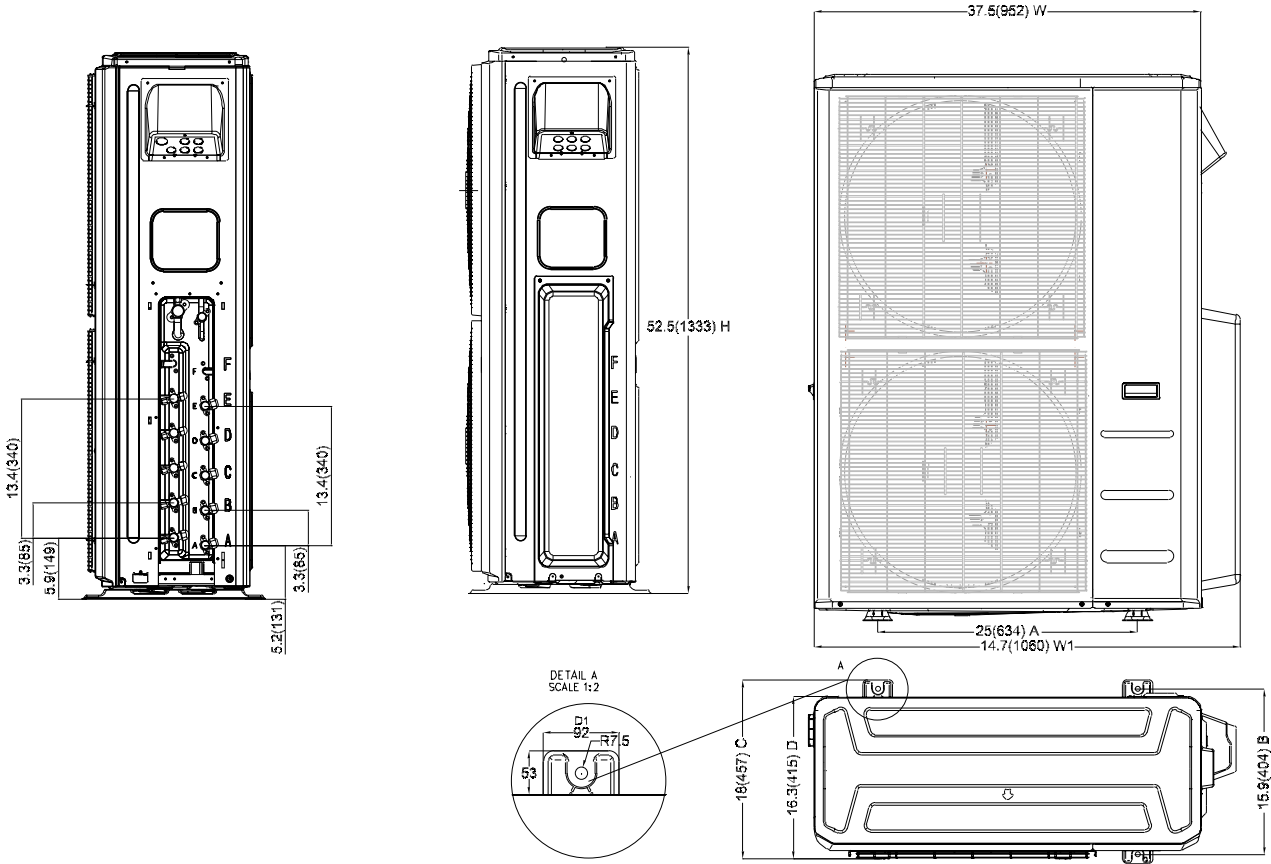

8. Centre of gravity

M2OA-18HFN1-M

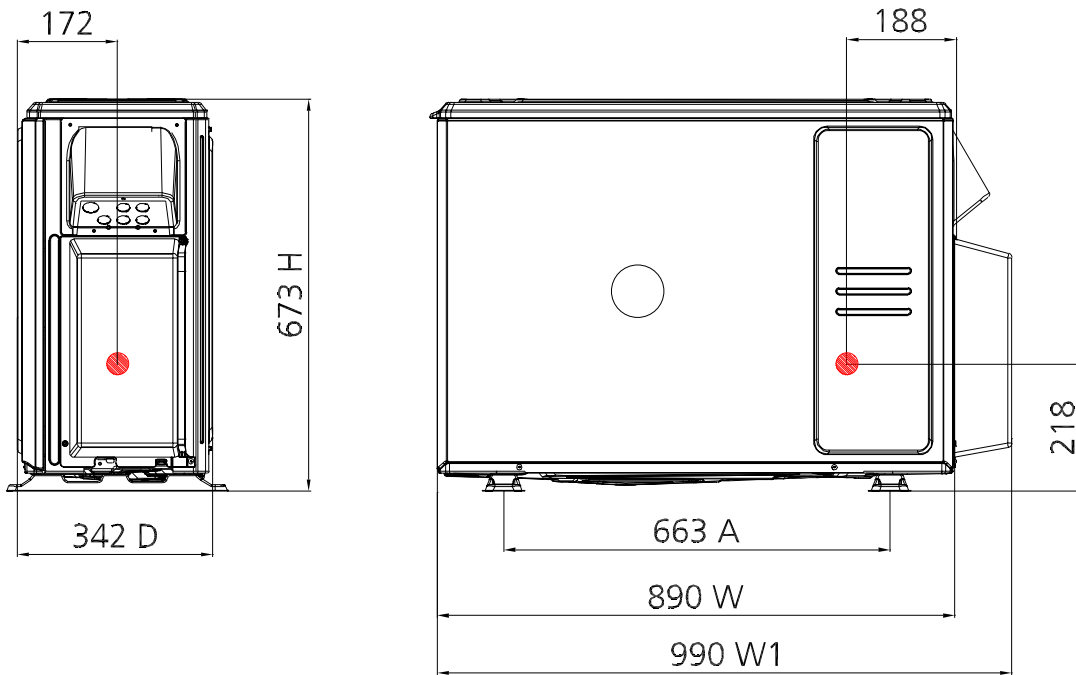

M3OJ-27HFN1-M, M4OG-36HFN1-M

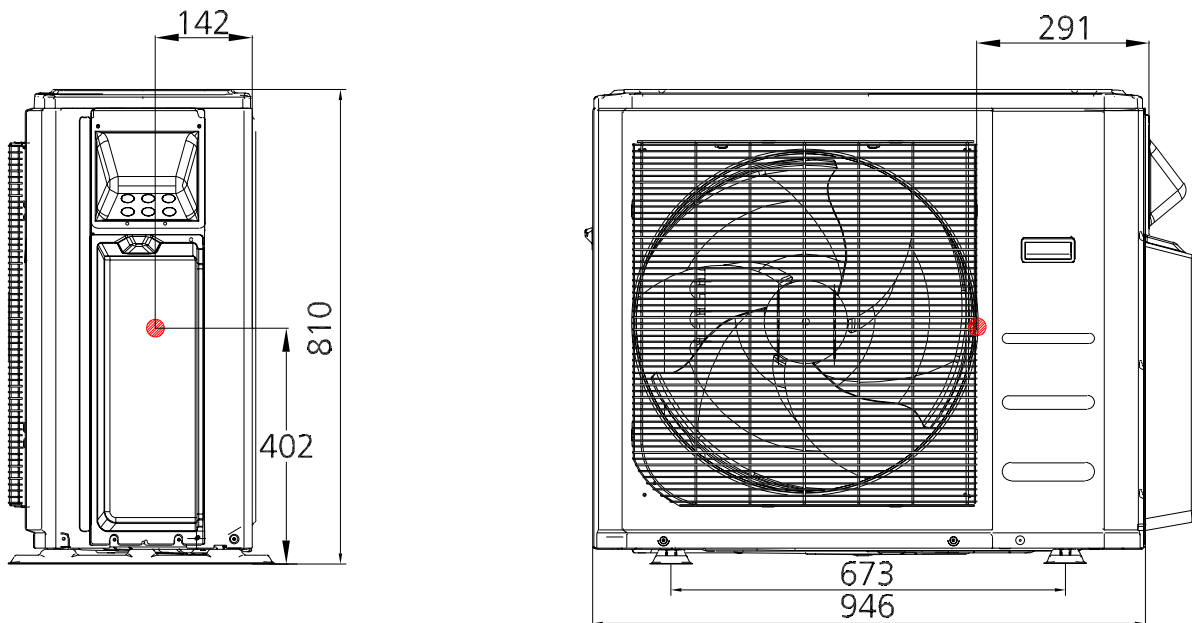

M5OG-48HFN1-M

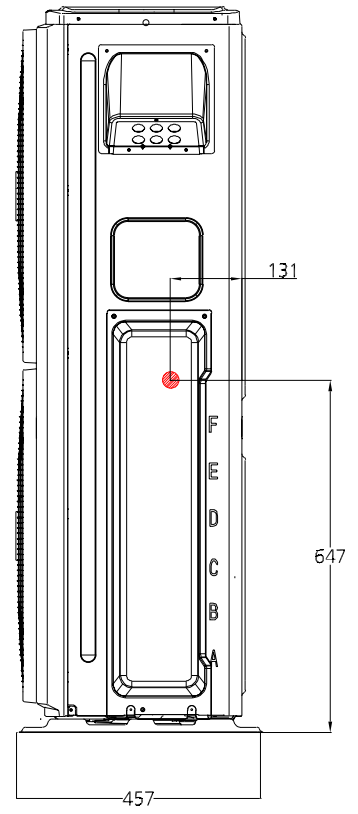
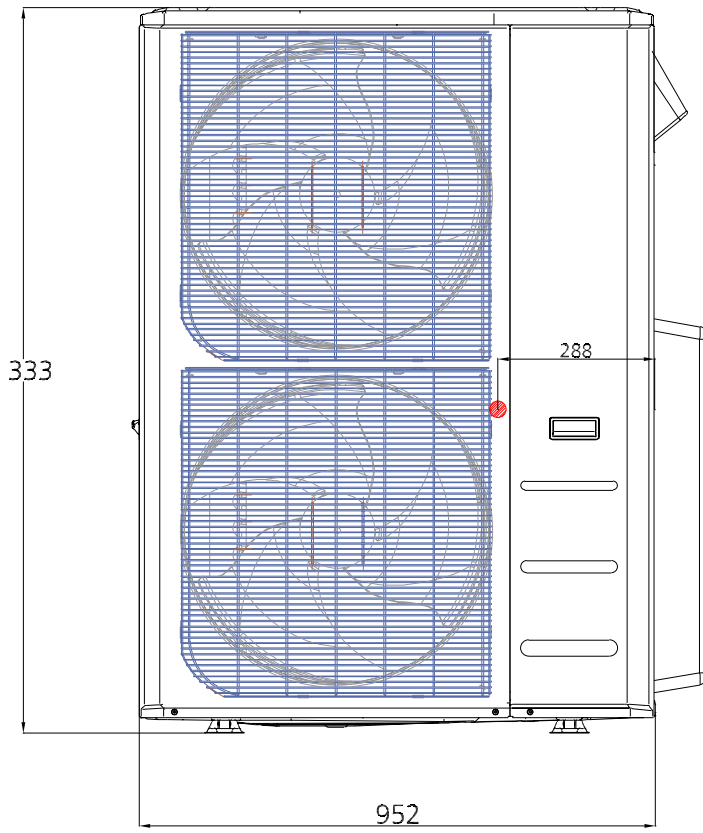

9. Air Velocity and Temperature Distributions

Compact Cassette type -9k &12k

Discharge Angle 30°

Cooling airflow velocity distributions

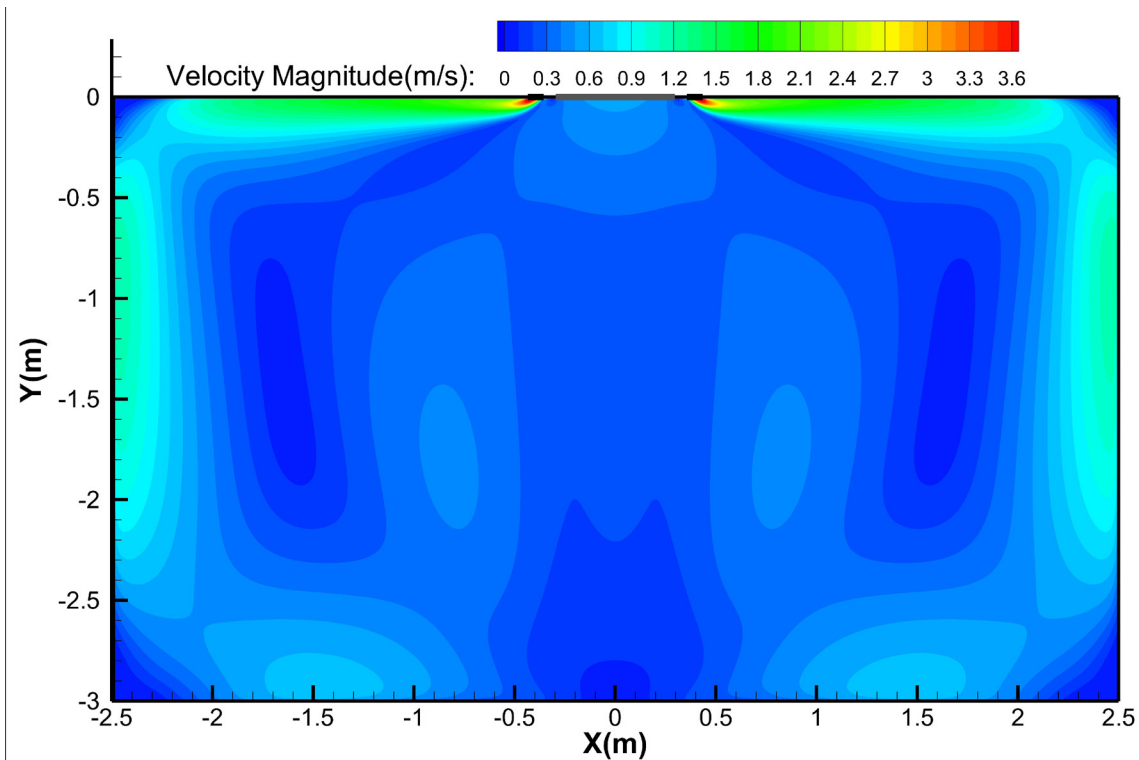

Cooling temperature distributions

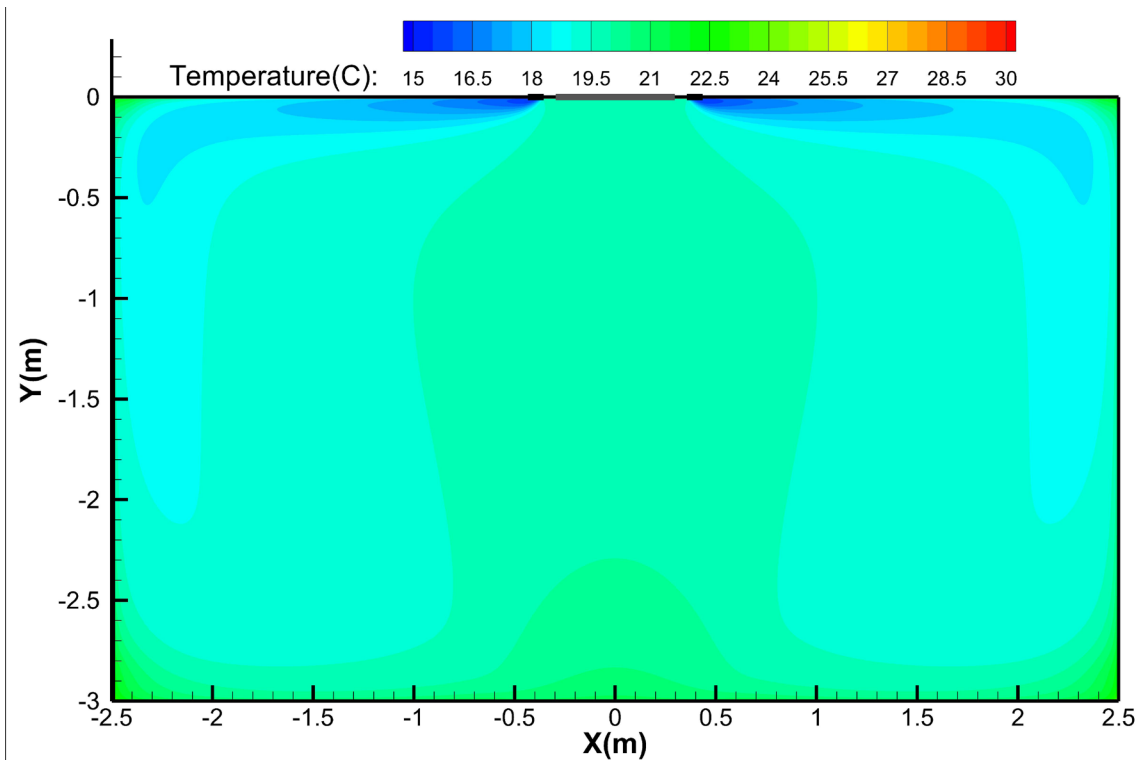

Compact Cassette type -9k & 12k

Heating airflow velocity distributions

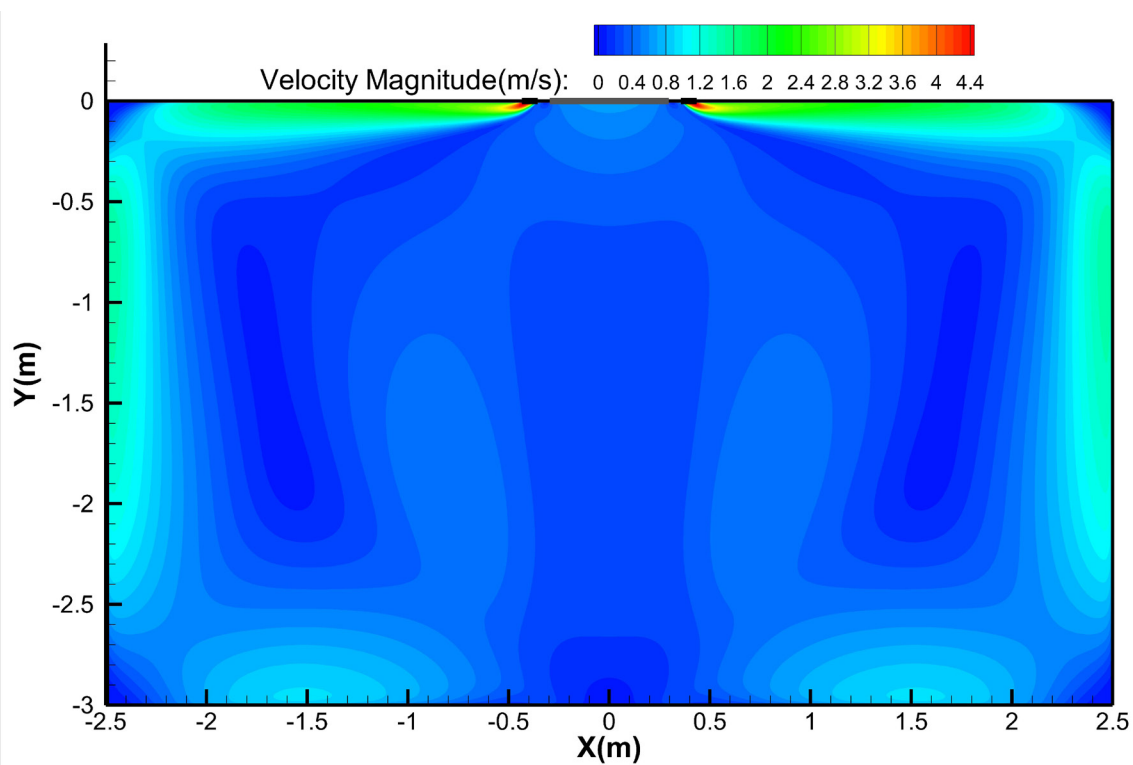

Heating temperature distributions

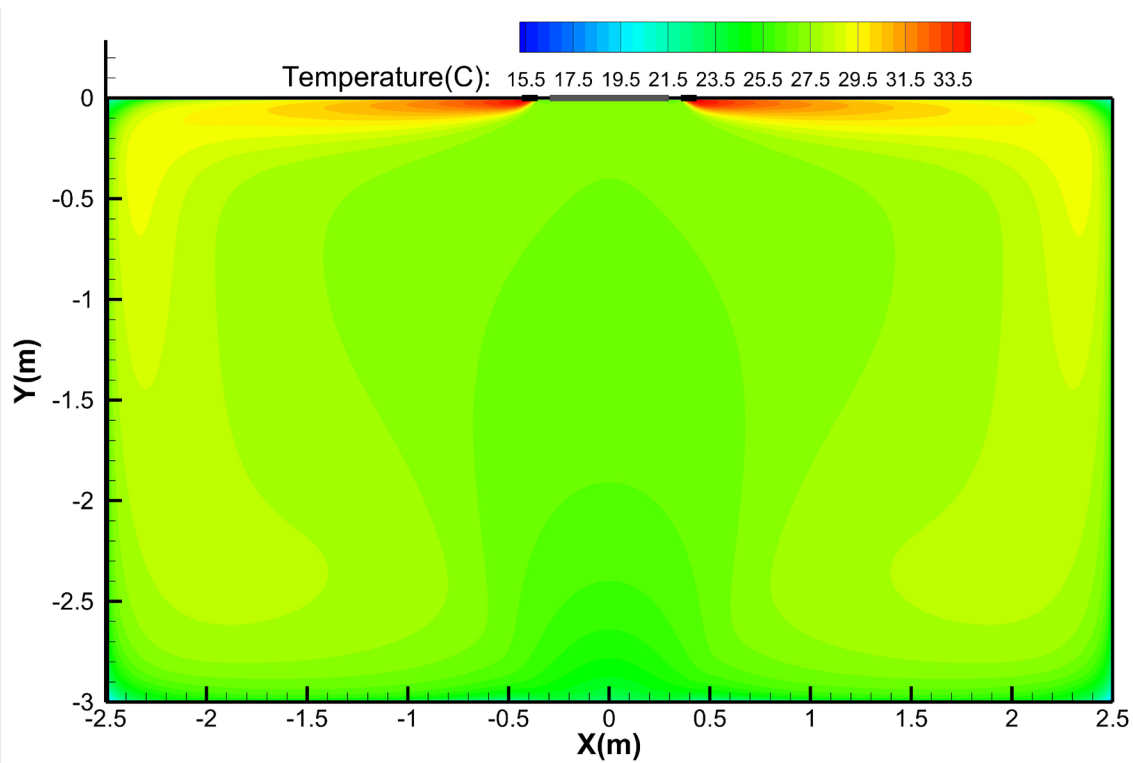

Compact Cassette type -9k &12k

Discharge Angle 60°

Cooling airflow velocity distributions

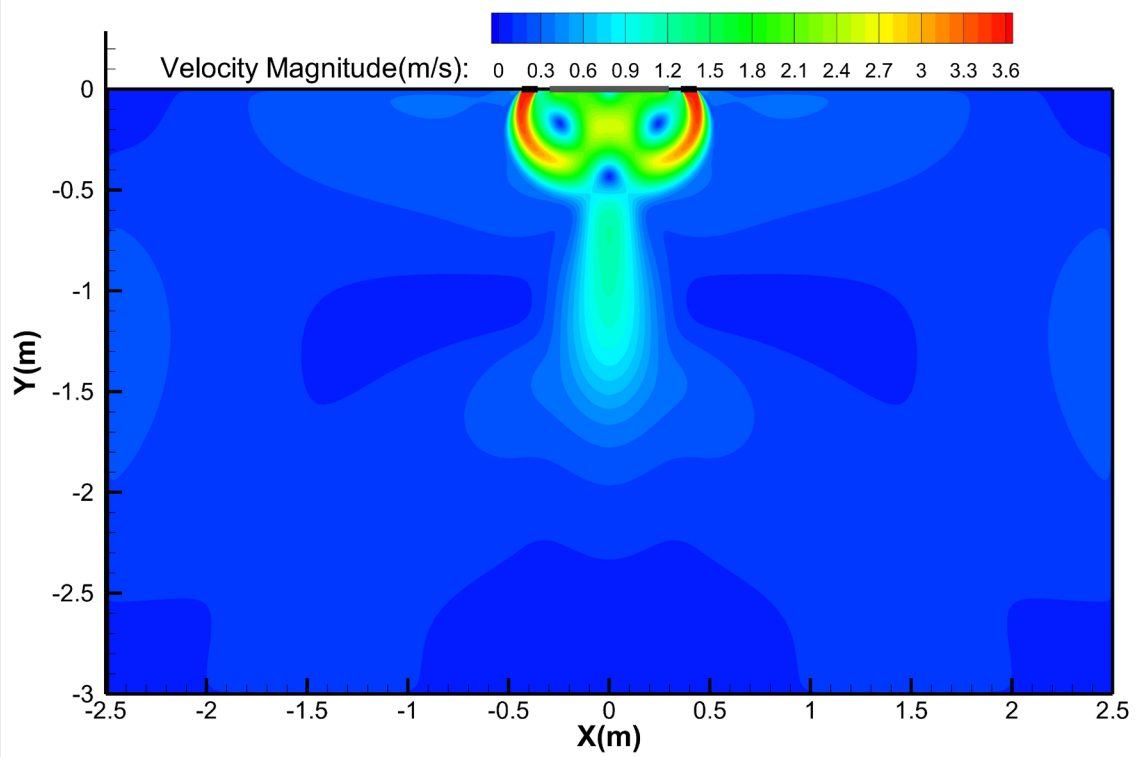

Cooling temperature distributions

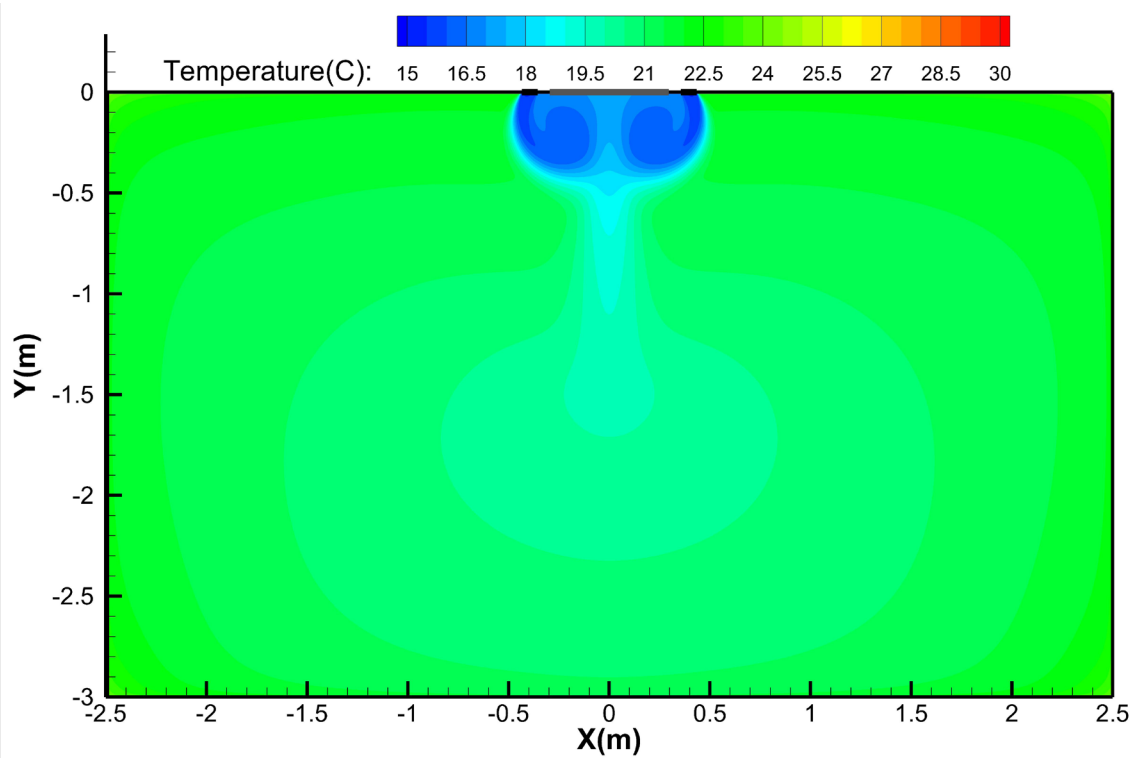

Compact Cassette type -9k &12k

Heating airflow velocity distributions

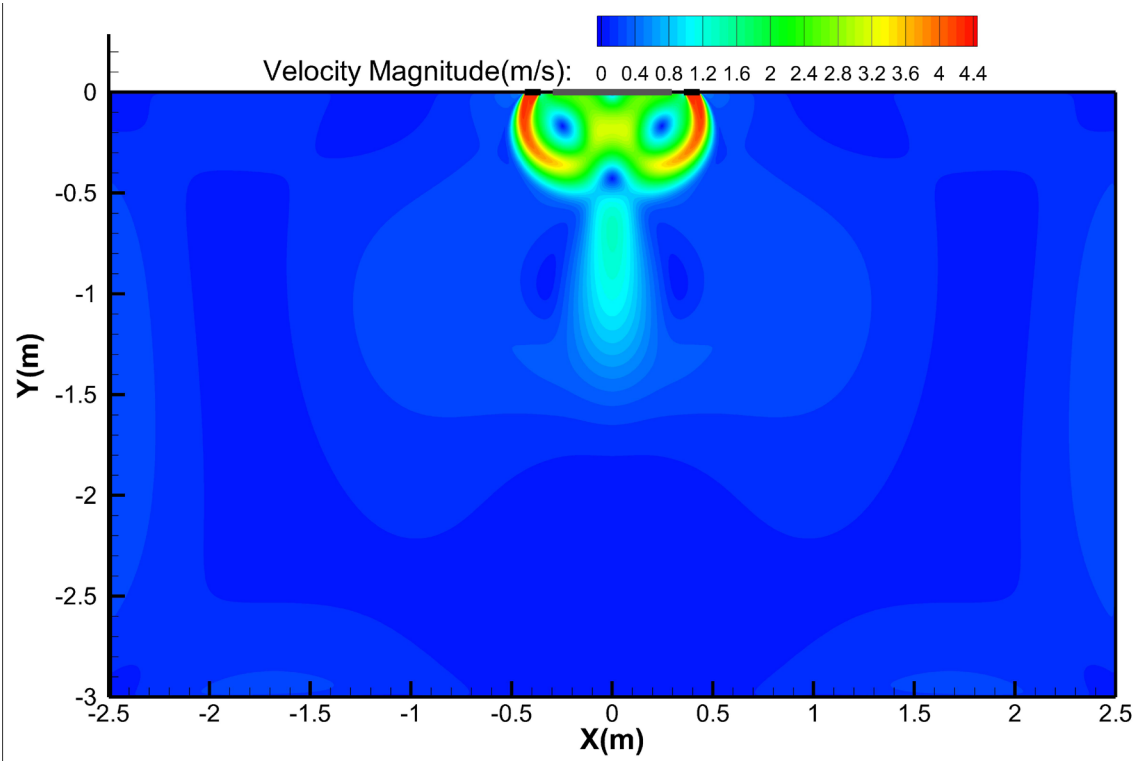

Heating temperature distributions

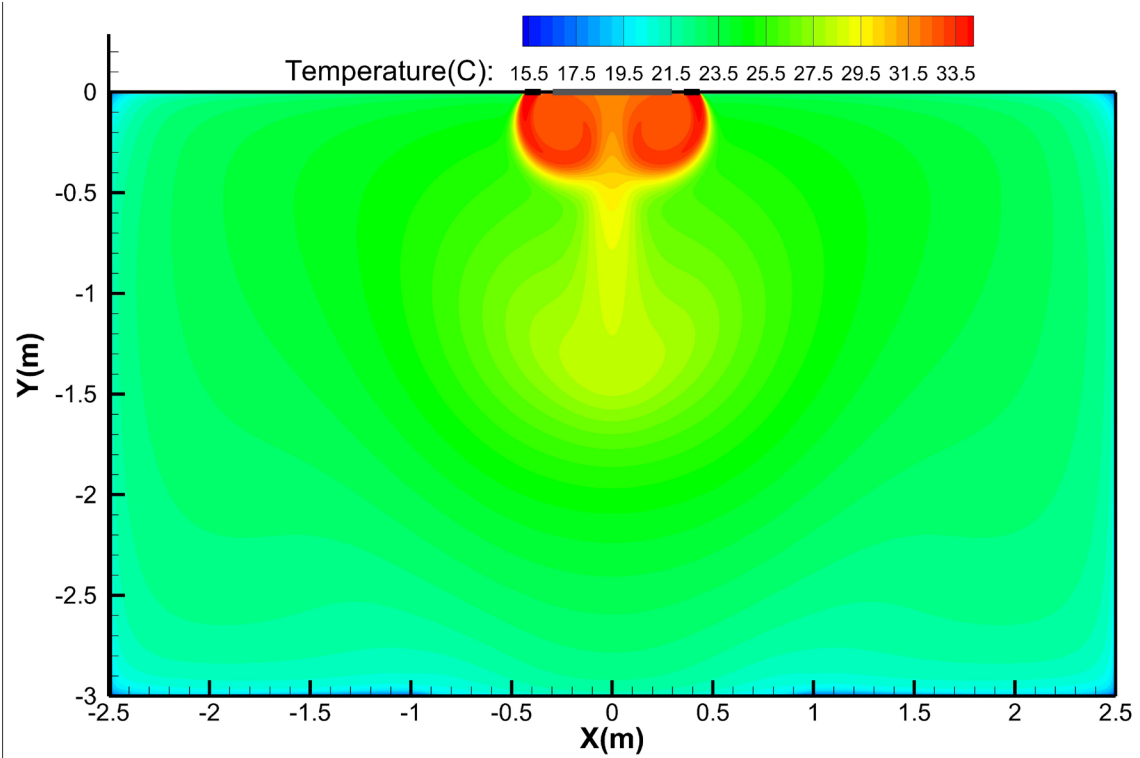

Compact Cassette type -18k

Discharge Angle 30°

Cooling airflow velocity distributions

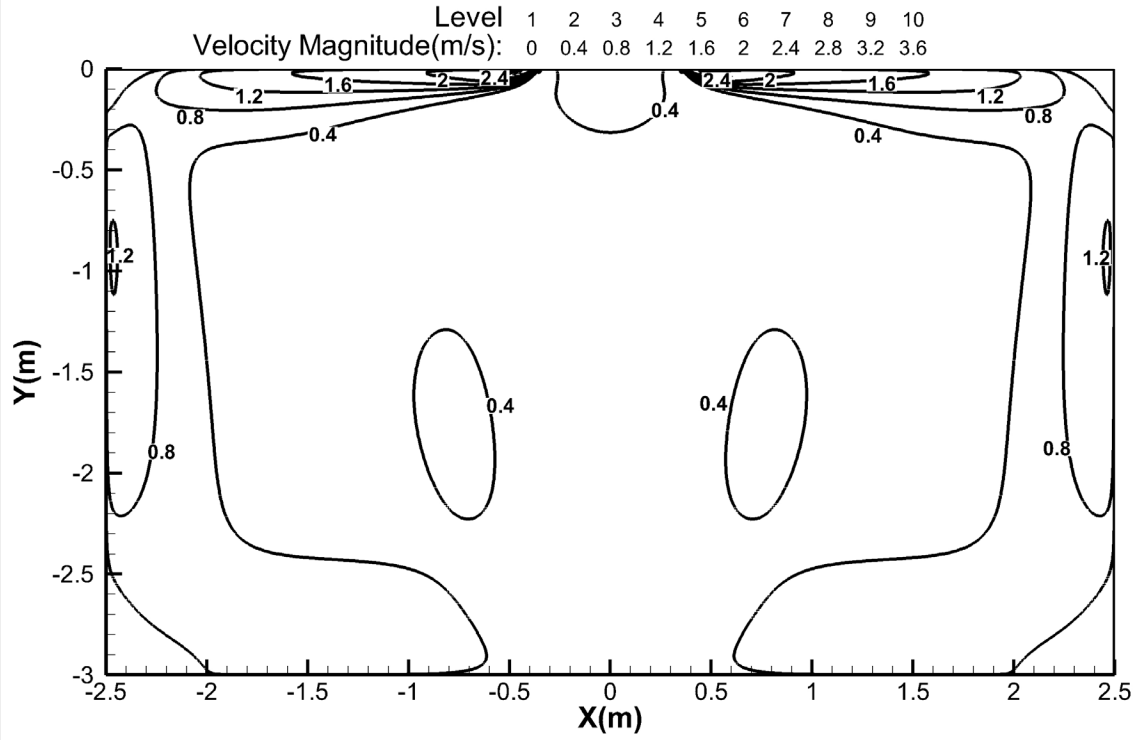

Cooling temperature distributions

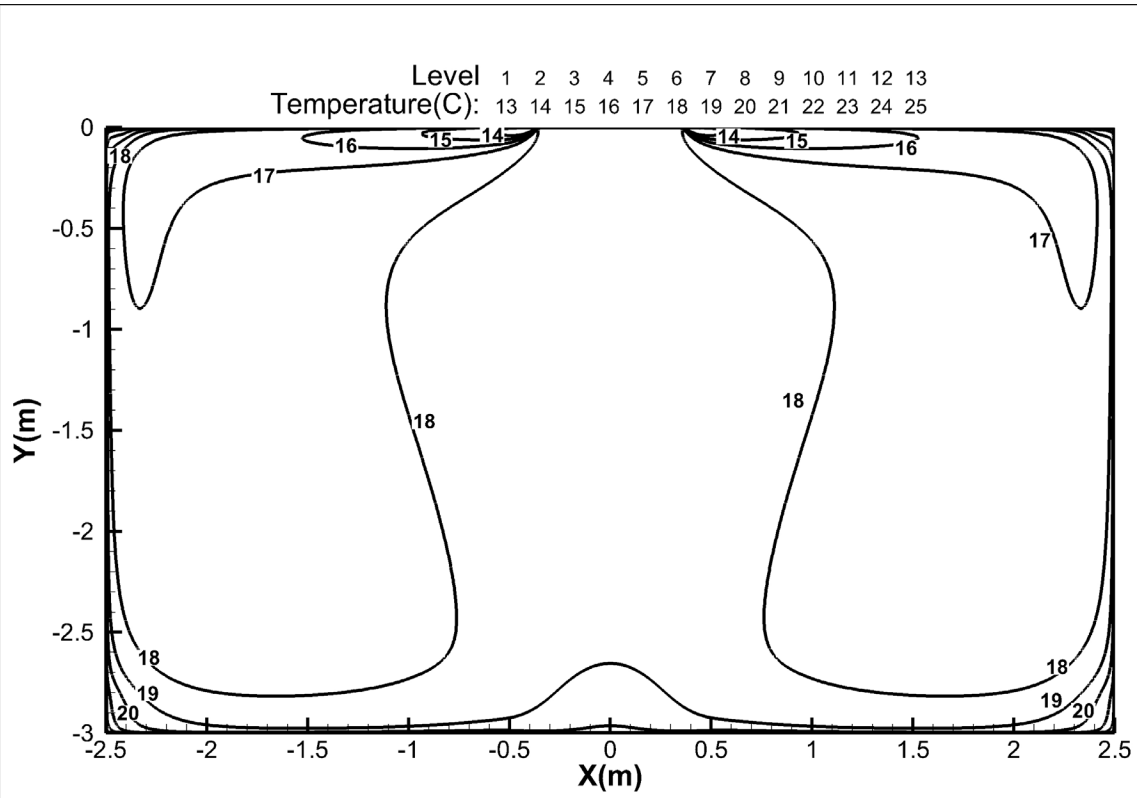

Compact Cassette type -18k

Heating airflow velocity distributions

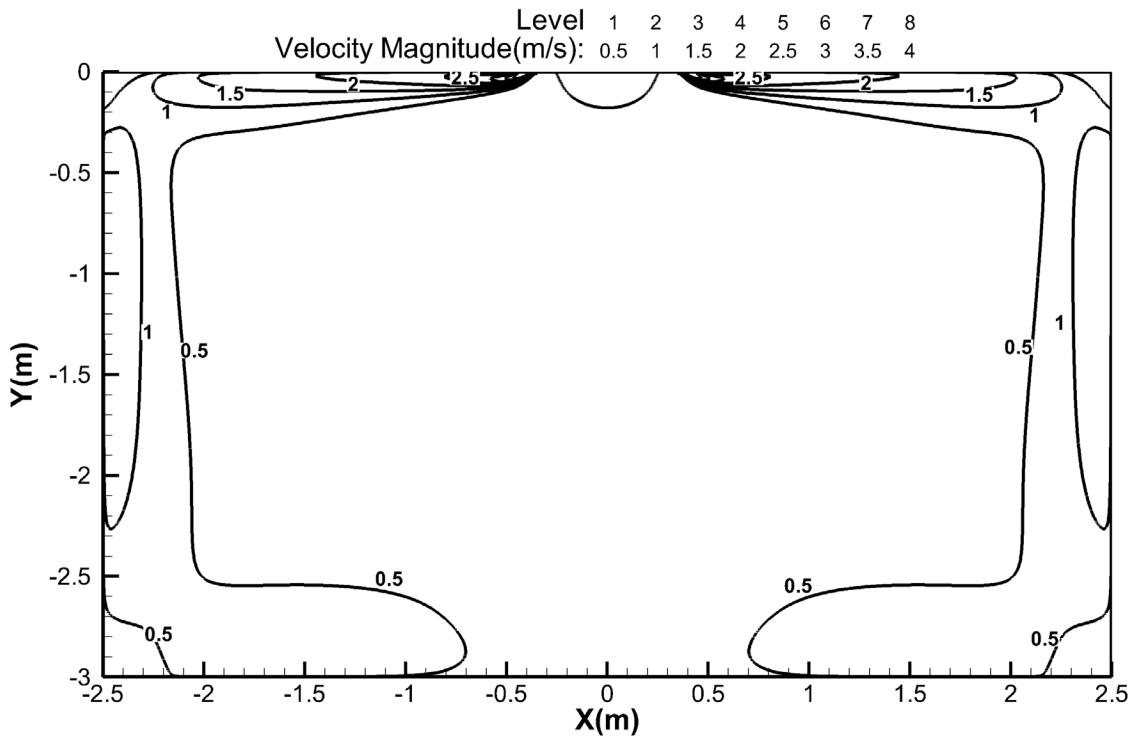

Heating temperature distributions

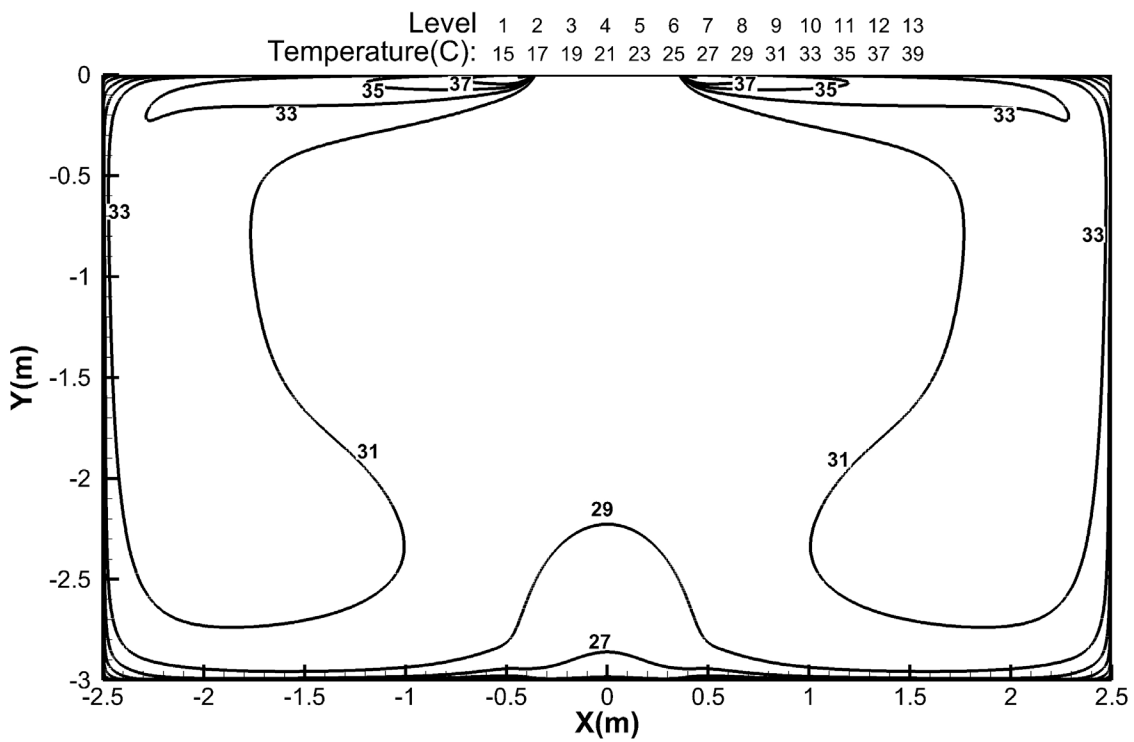

Compact Cassette type -18k

Discharge Angle 60°

Cooling airflow velocity distributions

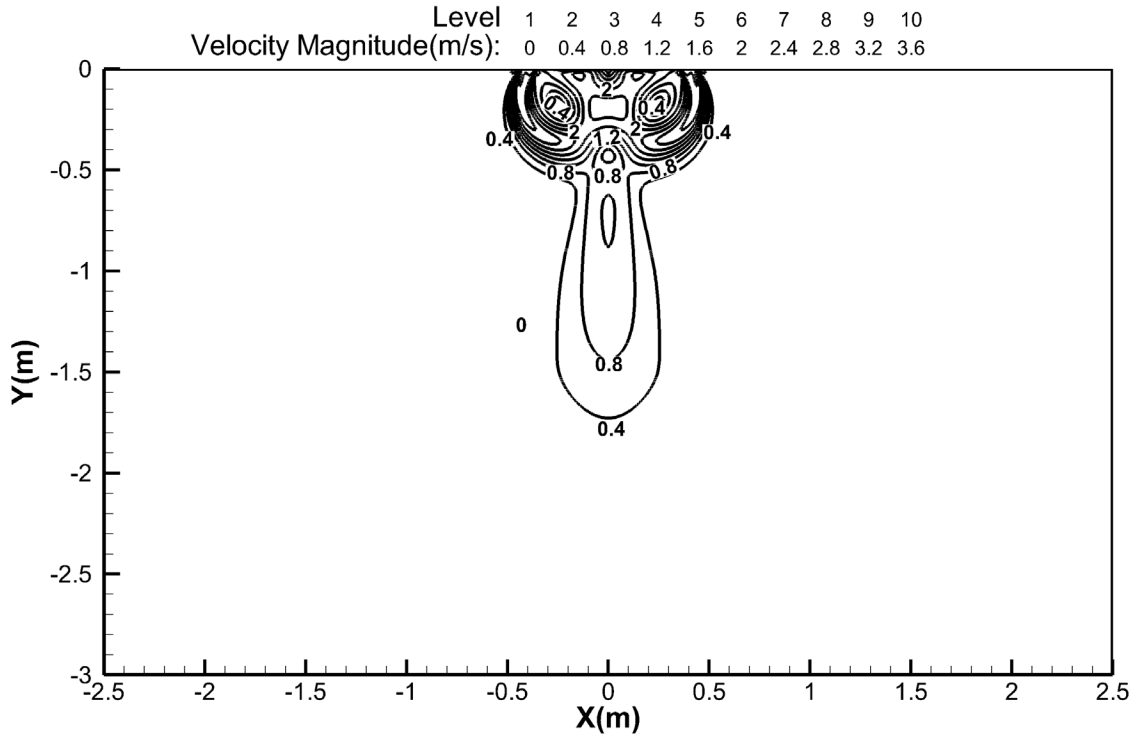

Cooling temperature distributions

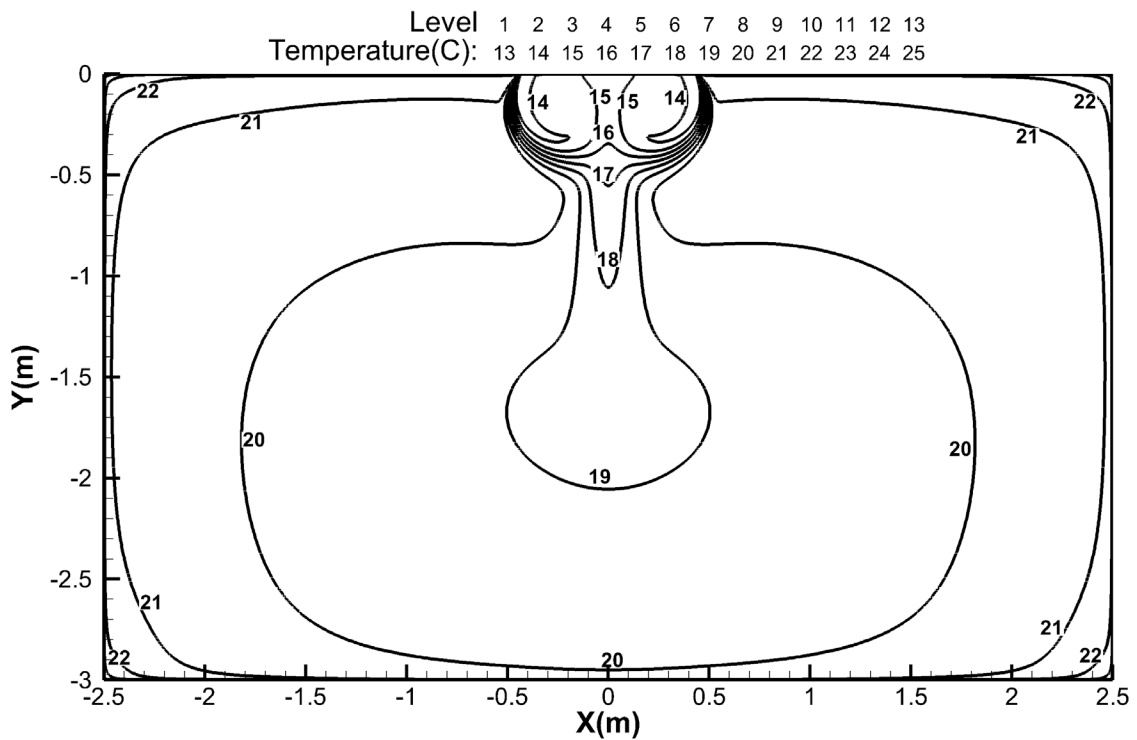

Compact Cassette type -18k

Heating airflow velocity distributions

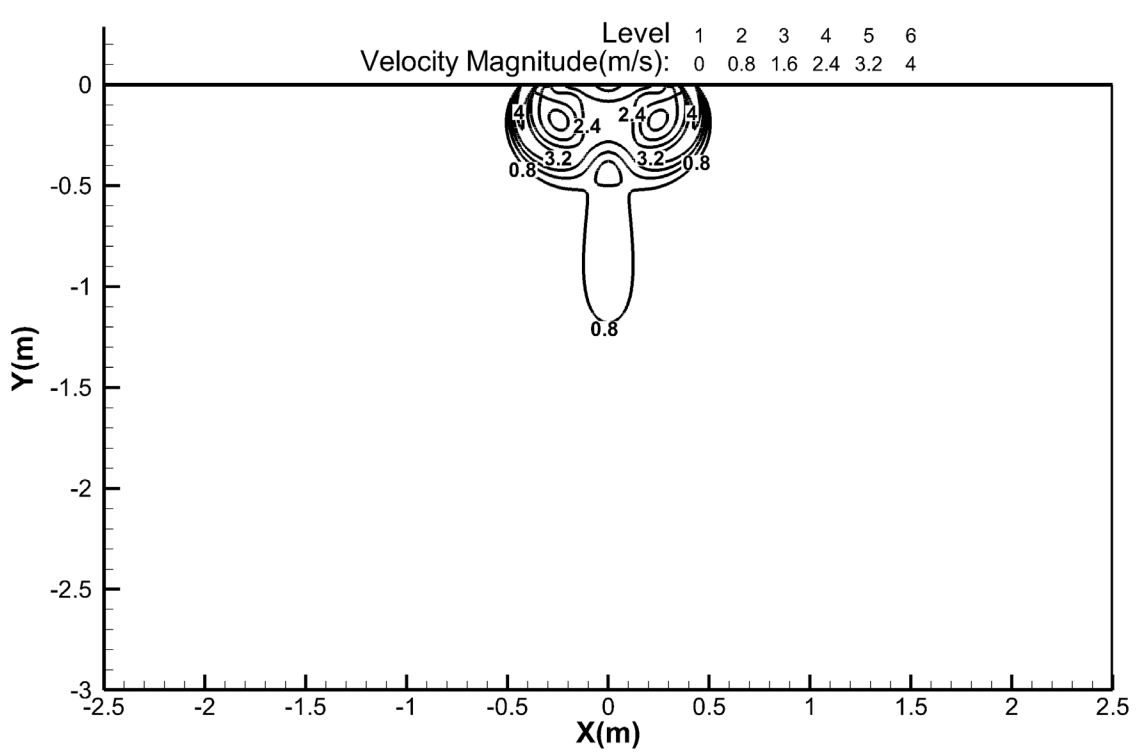

Heating temperature distributions

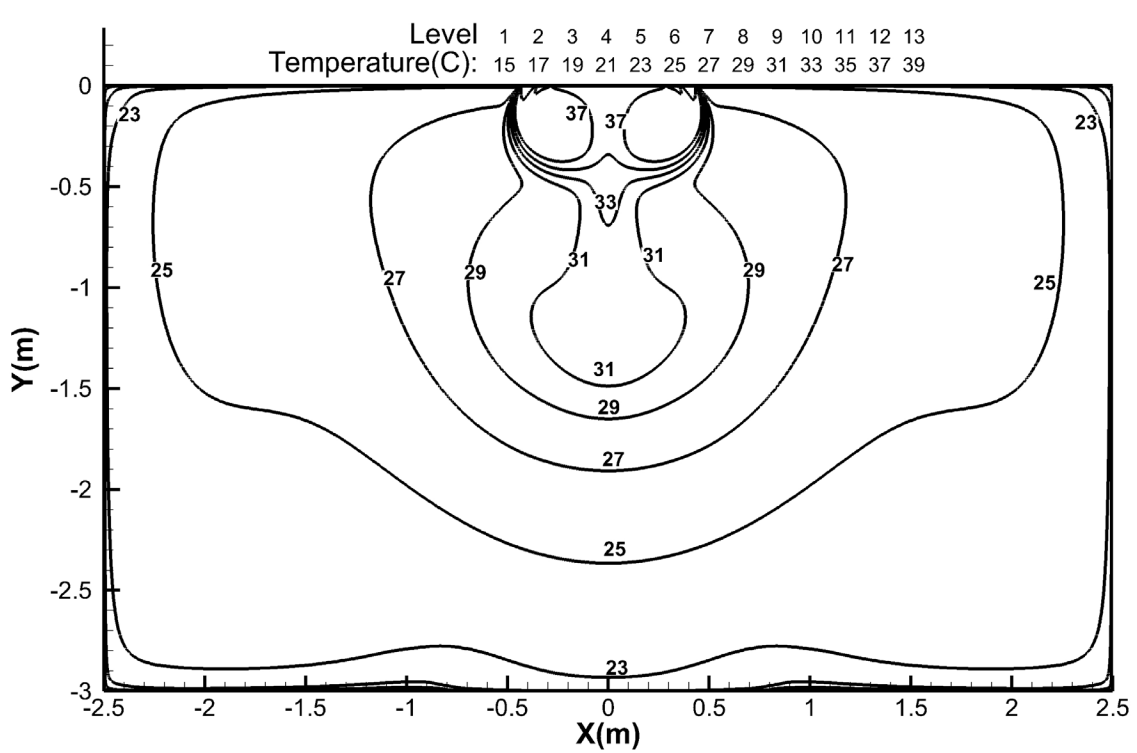

New 4-way Cassette type -24k

Cooling airflow velocity distributions

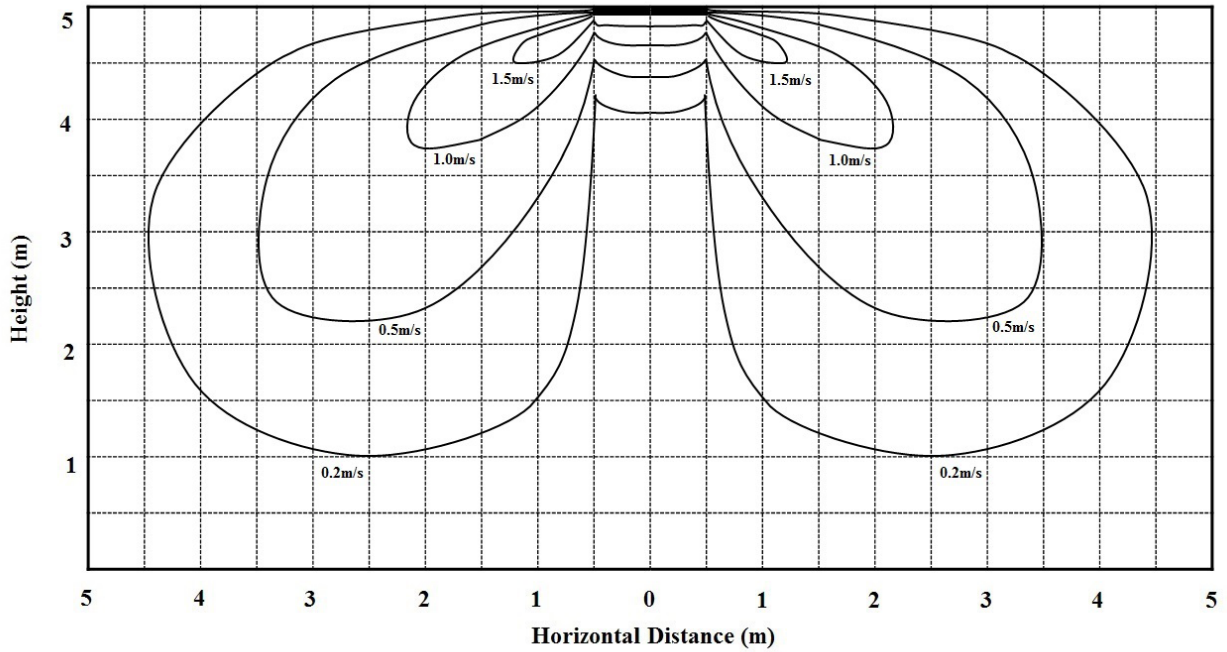

Cooling temperature distributions

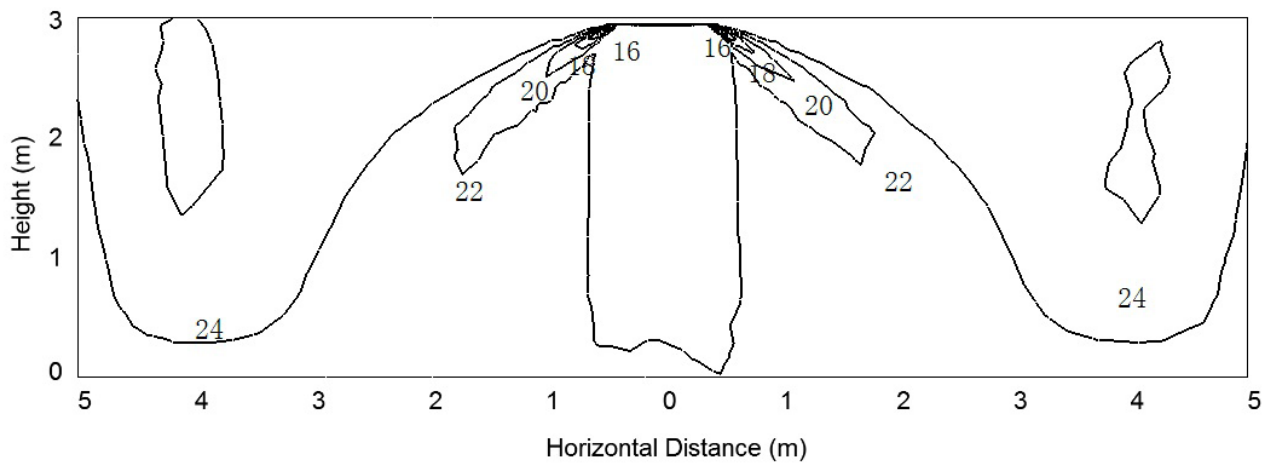

New 4-way Cassette type -24k

Heating airflow velocity distributions

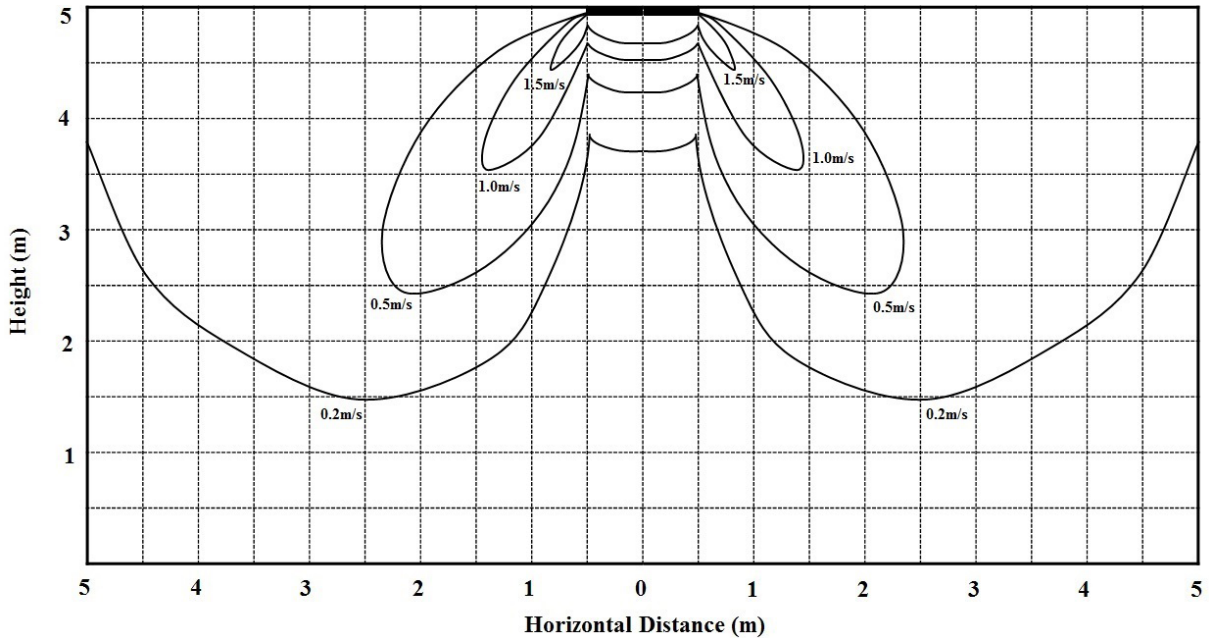

Heating temperature distributions

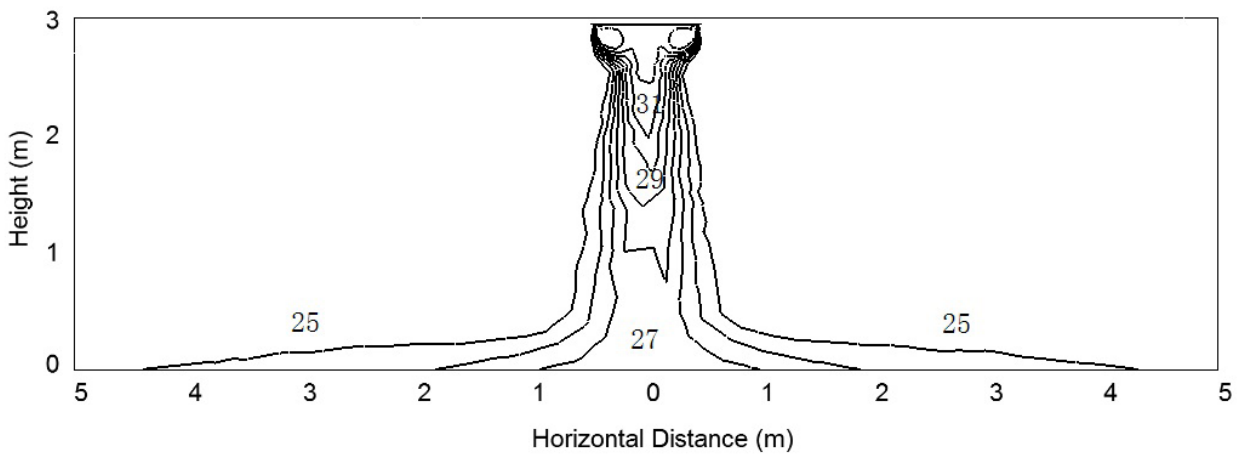

Floor Ceiling Type -18k

Ceiling installation:

Discharge Angle 30°

Cooling airflow velocity distributions

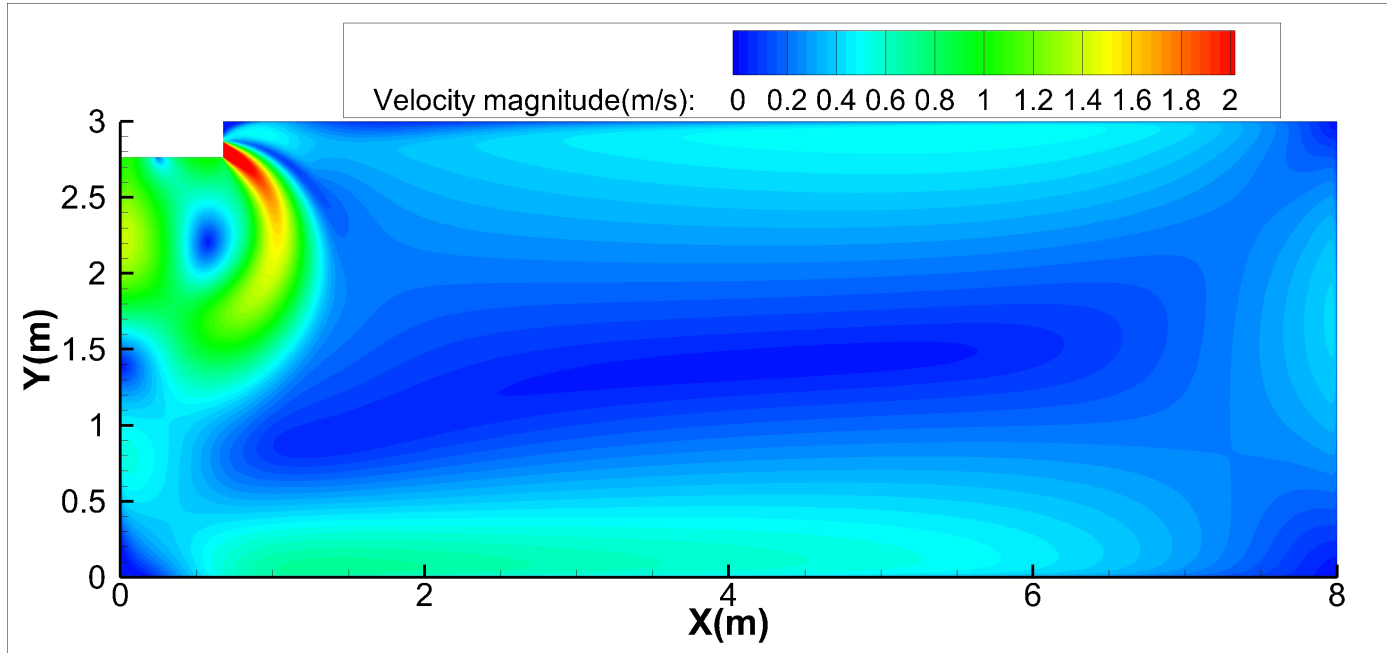

Specifications

Cooling temperature distributions

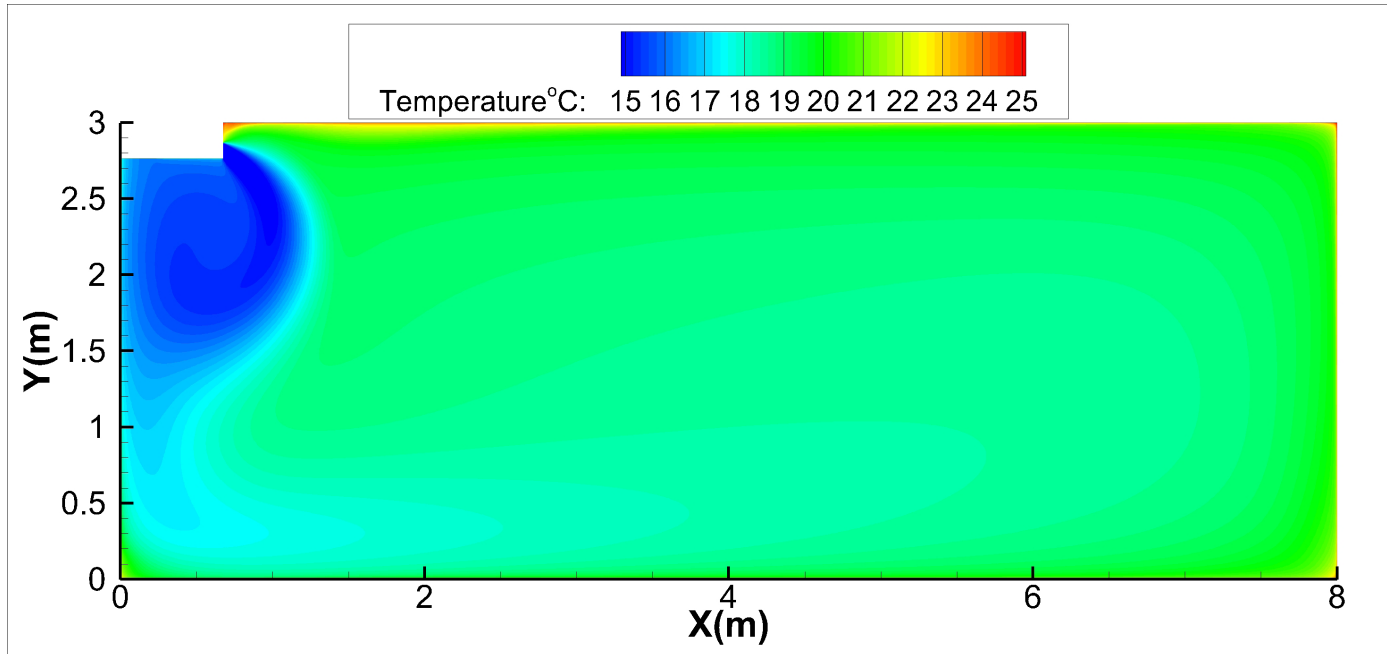

Floor Ceiling Type -18k

Ceiling installation:

Discharge Angle 60°

Cooling airflow velocity distributions

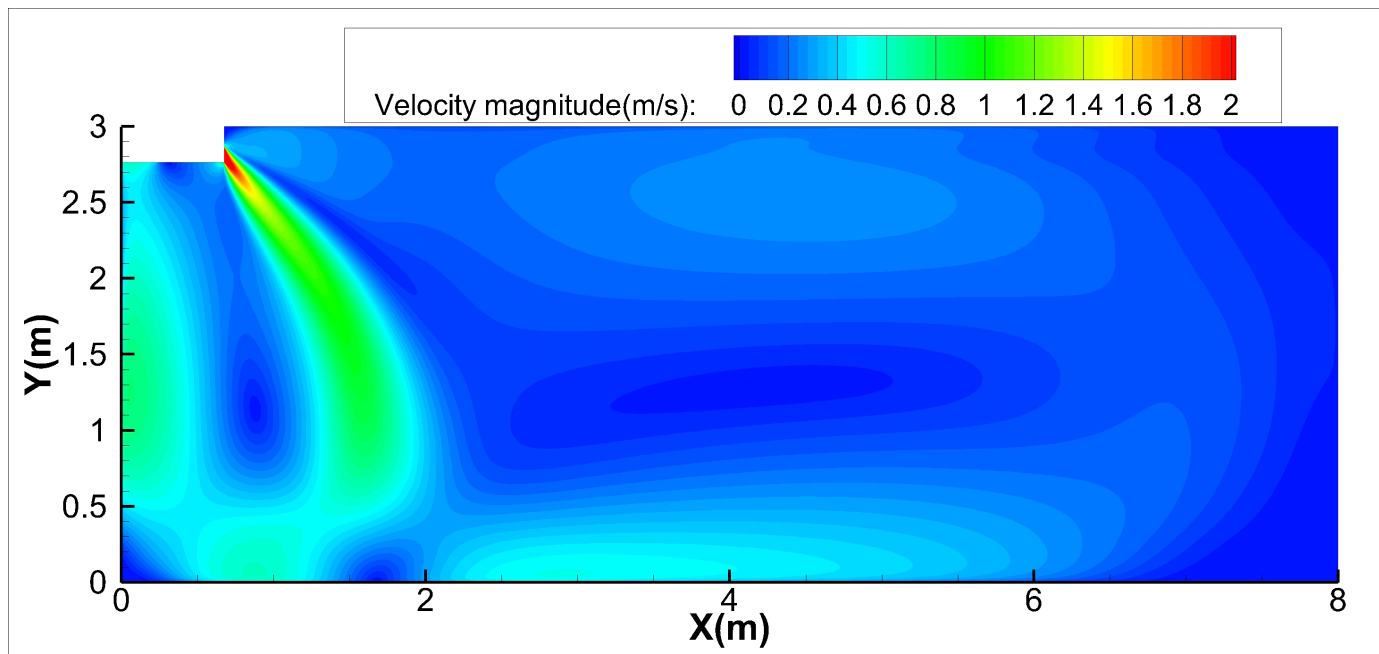

Cooling temperature distributions

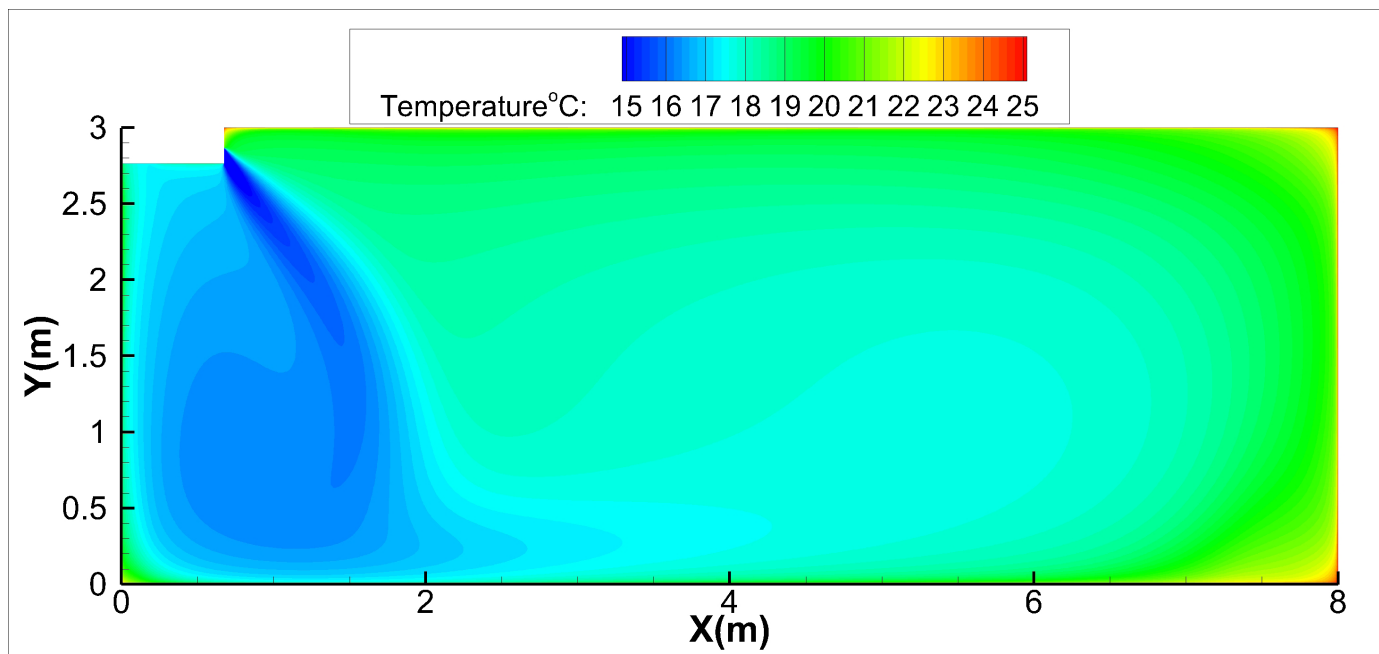

Floor Ceiling Type -18k

Ceiling installation:

Discharge Angle 30°

Heating airflow velocity distributions

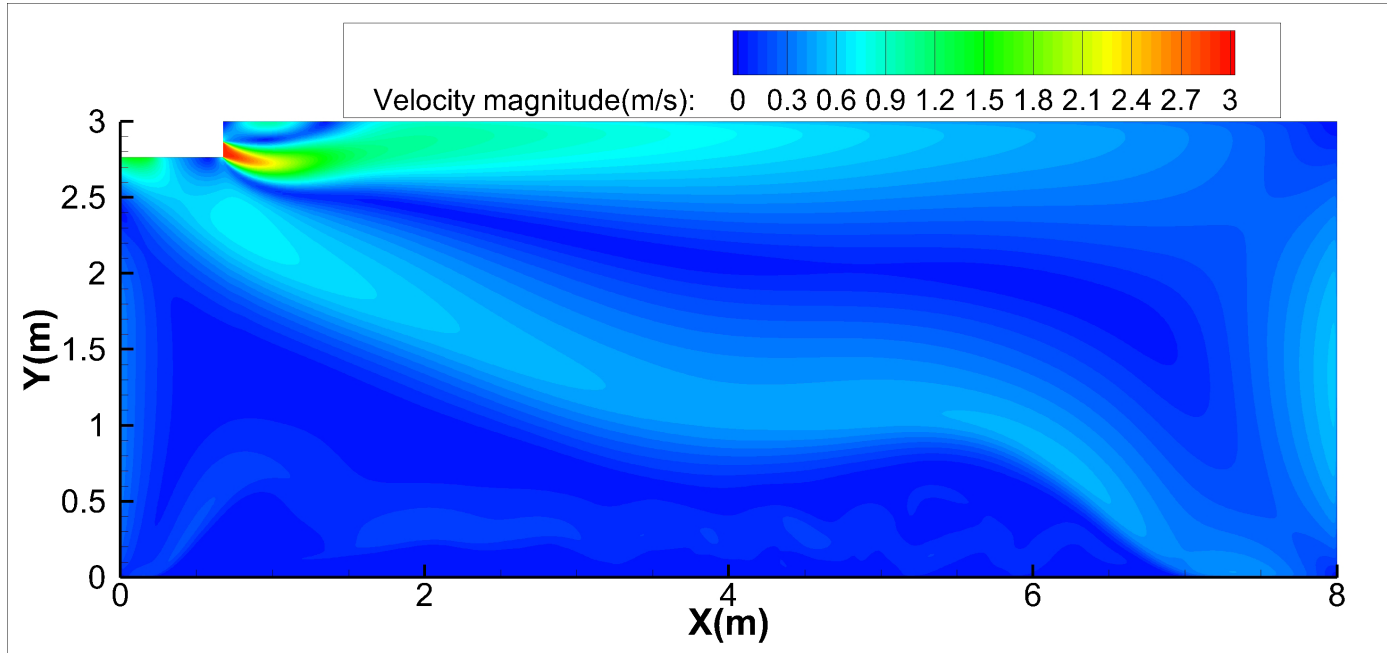

Specifications

Heating temperature distributions

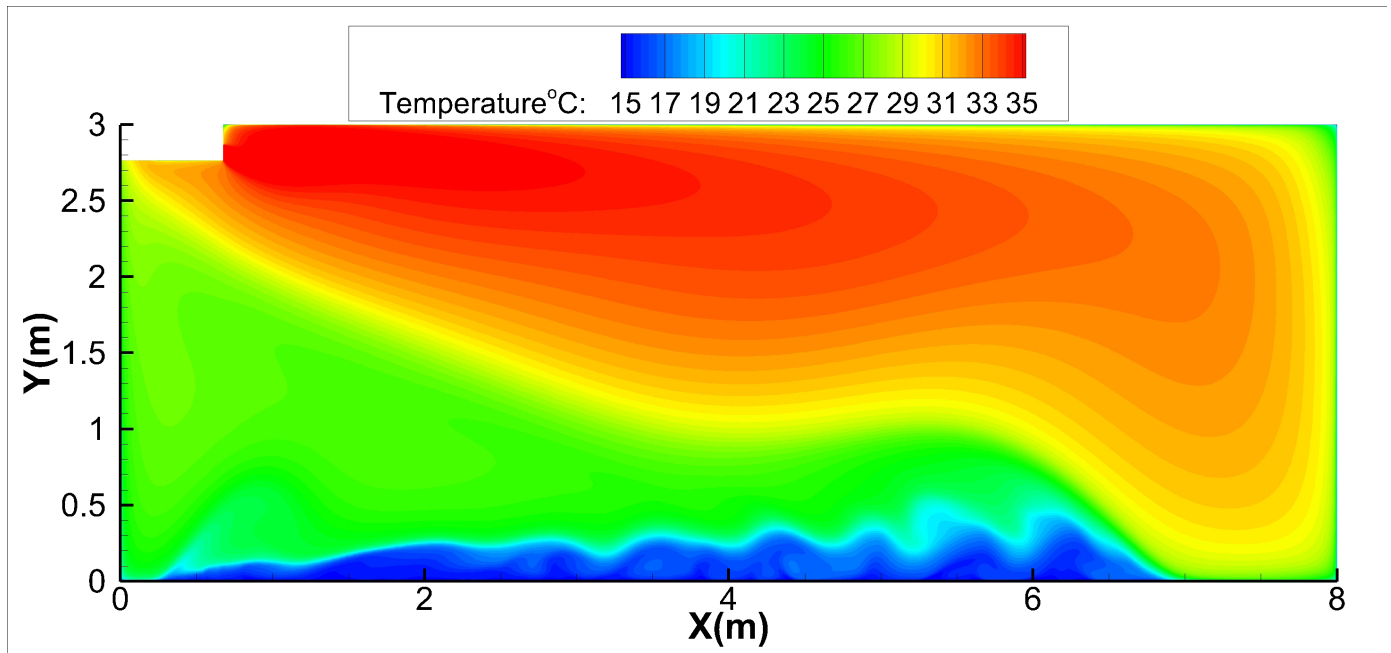

Floor Ceiling Type -18k

Ceiling installation:

Discharge Angle 60°

Heating airflow velocity distributions

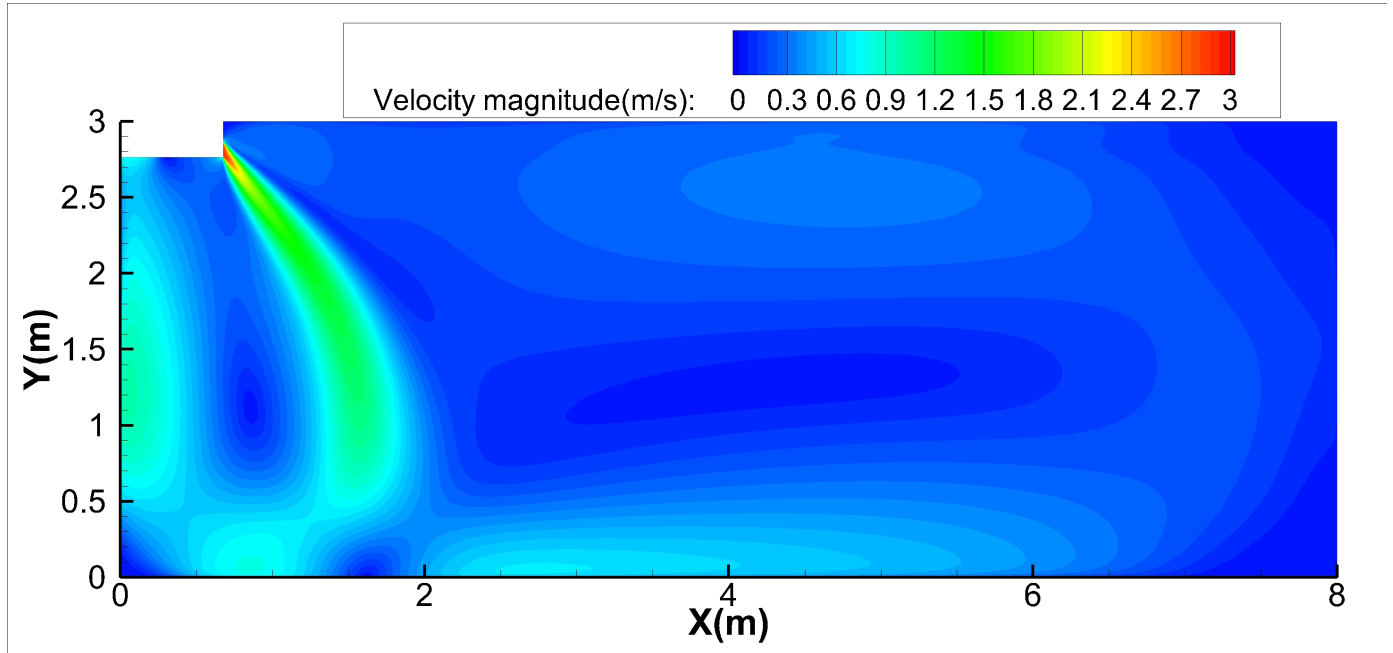

Heating temperature distributions

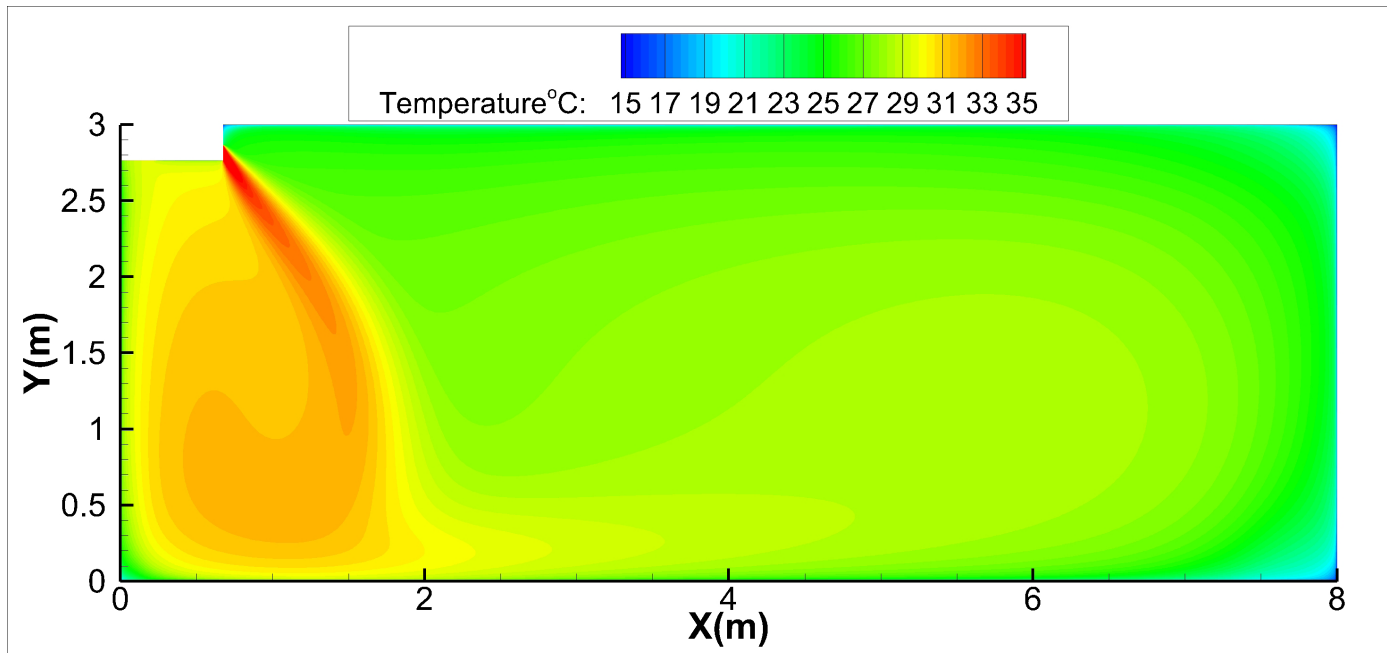

Floor Ceiling Type -18k

Floor installation:

Discharge Angle 30°

Cooling airflow velocity distributions

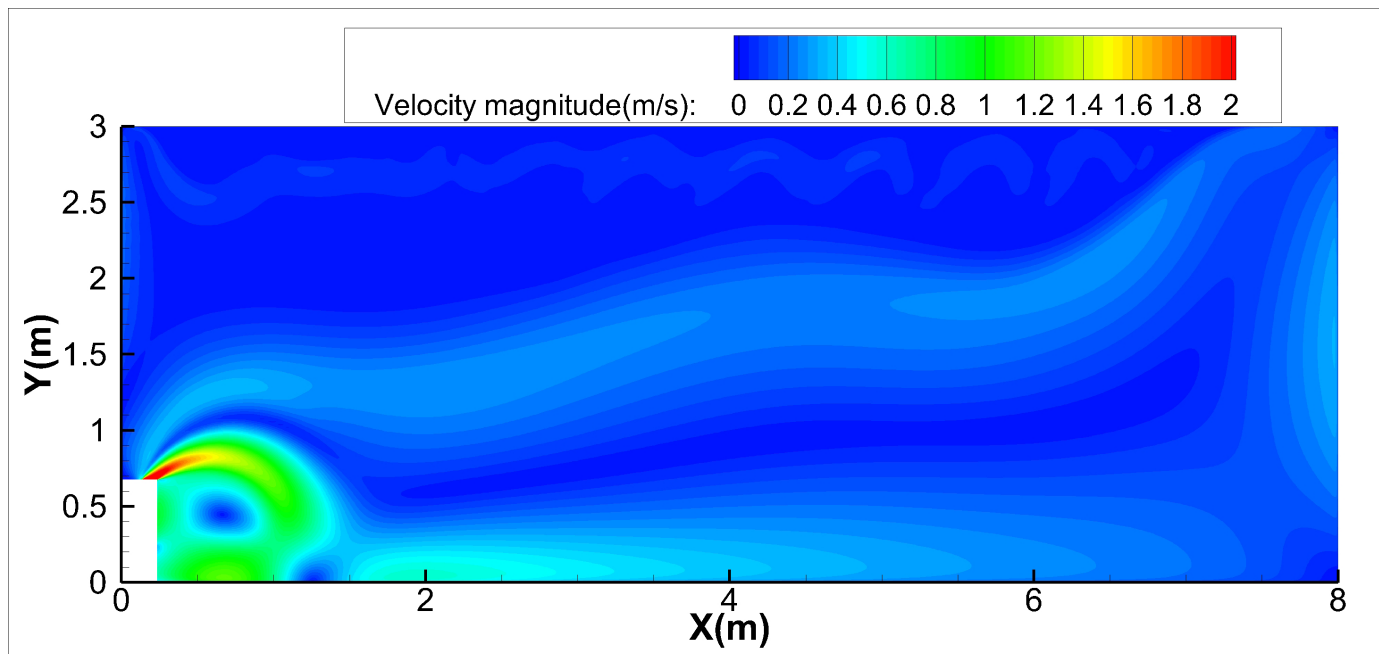

Specifications

Cooling temperature distributions

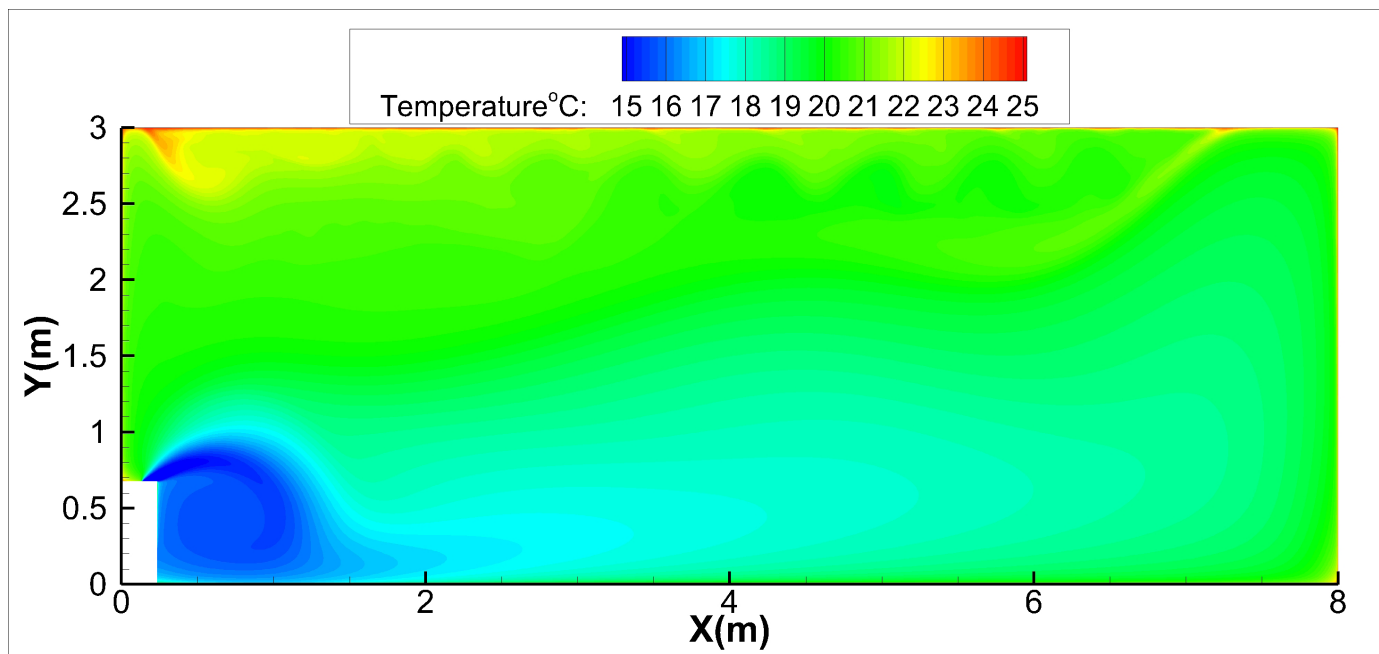

Floor Ceiling Type -18k

Floor installation:

Discharge Angle 60°

Cooling airflow velocity distributions

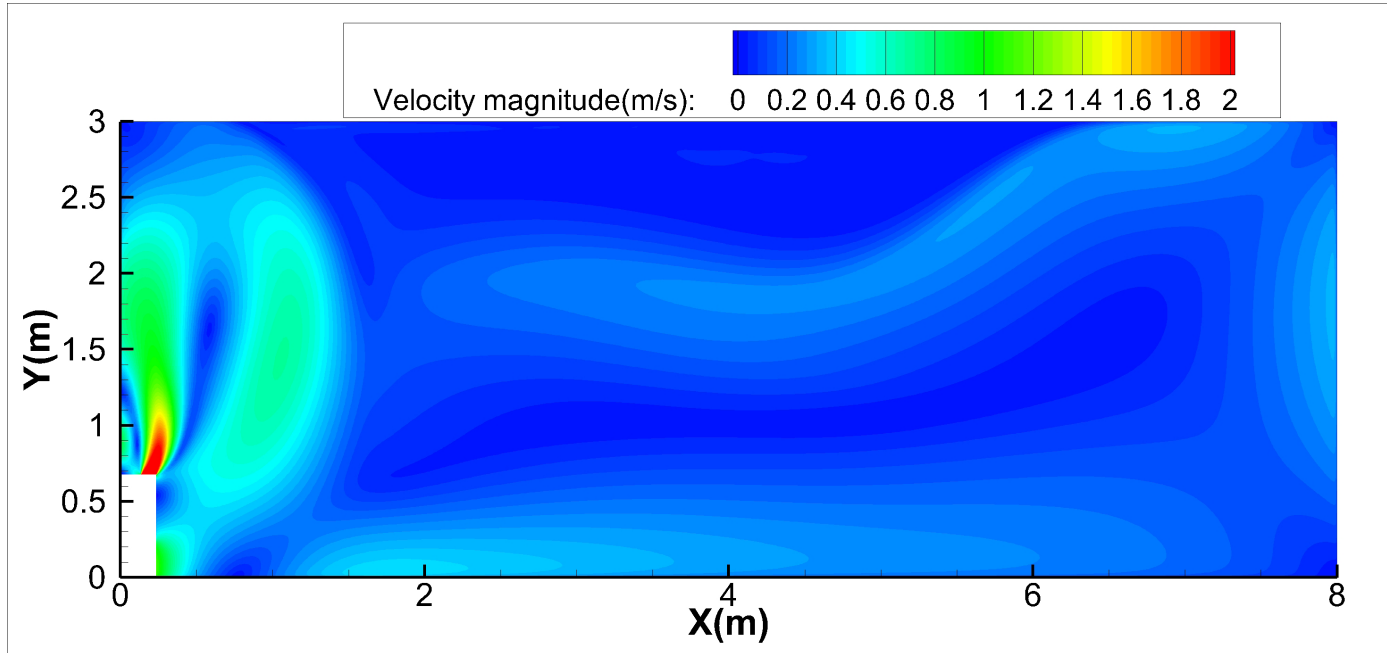

Cooling temperature distributions

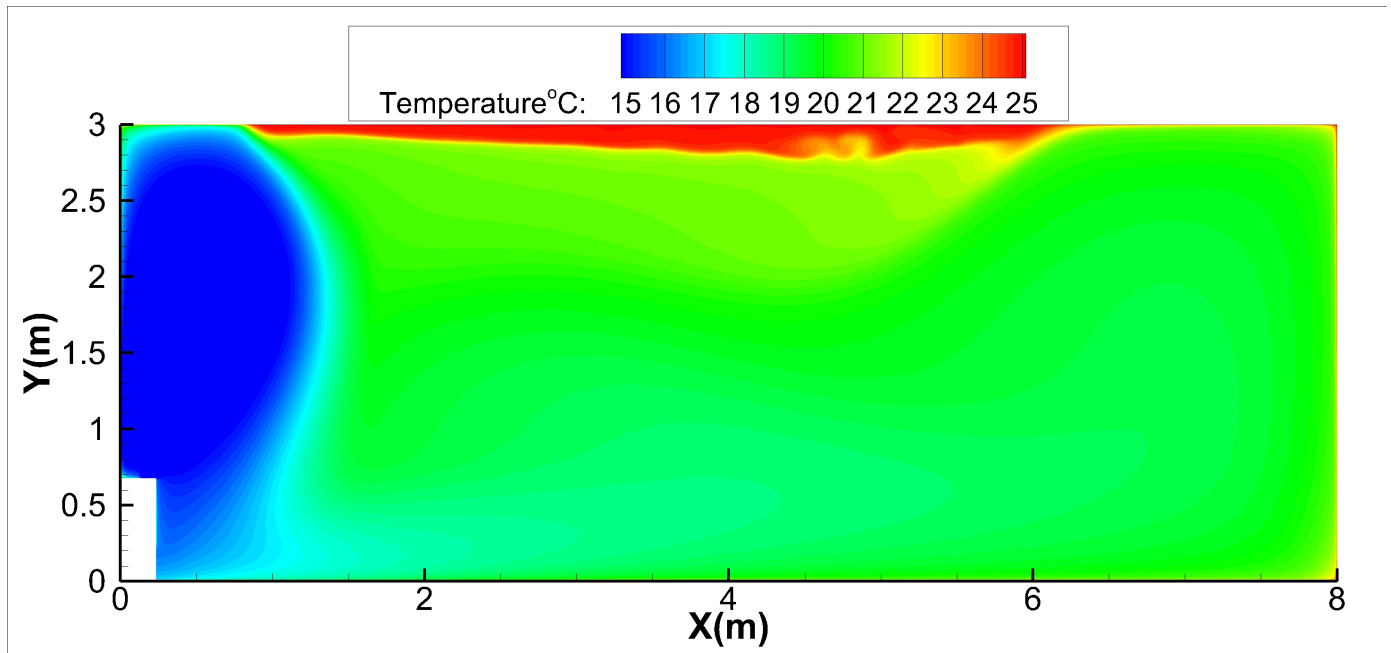

Floor Ceiling Type -18k

Floor installation:

Discharge Angle 30°

Heating airflow velocity distributions

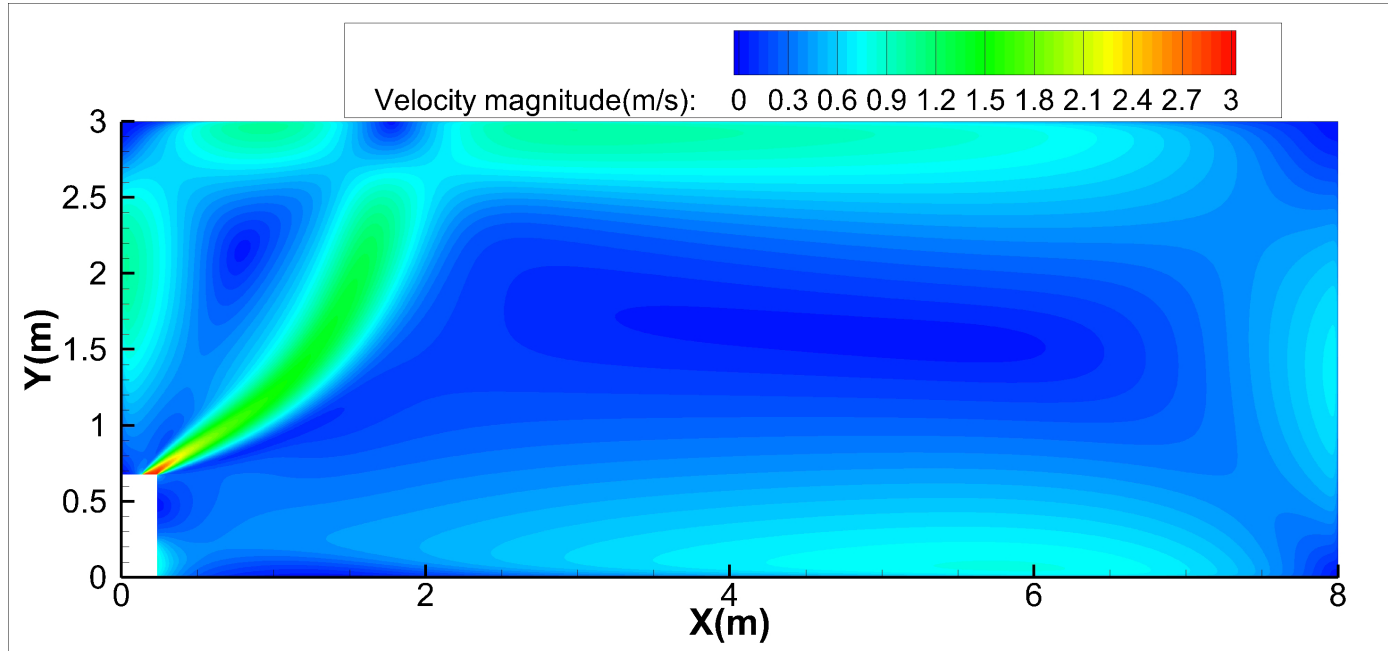

Specifications

Heating temperature distributions

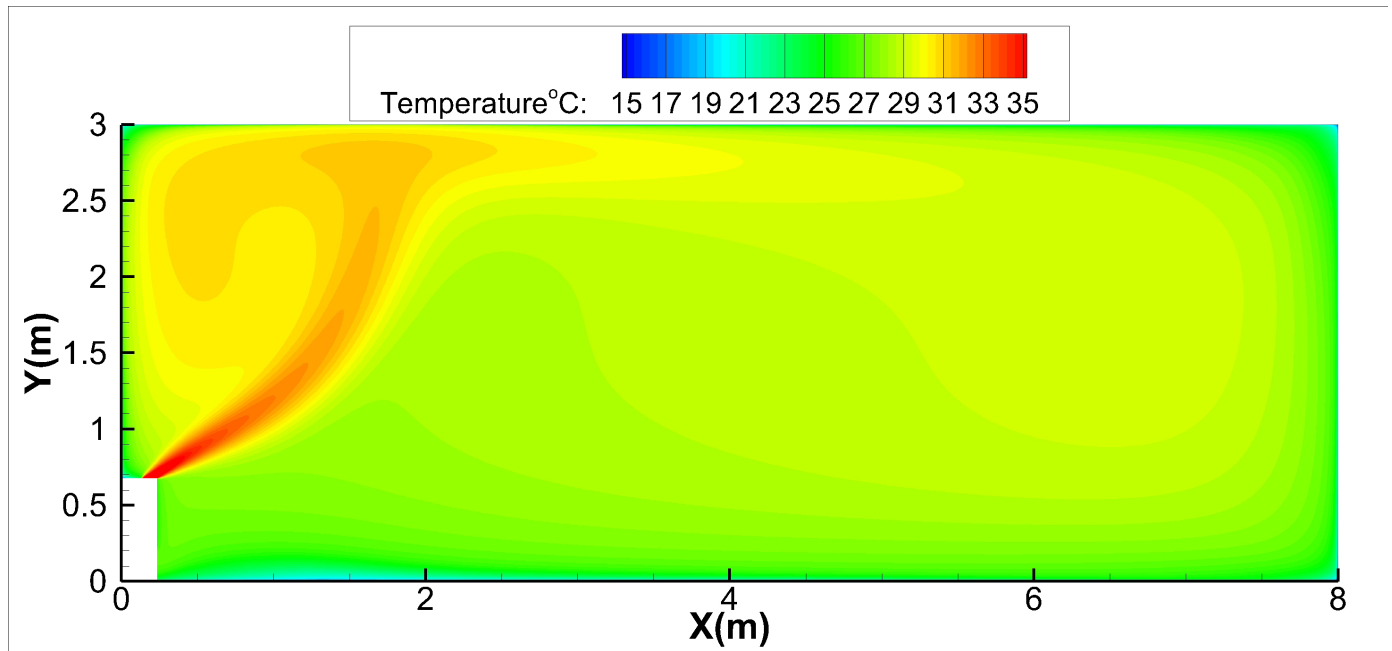

Floor Ceiling Type -18k

Floor installation:

Discharge Angle 60°

Heating airflow velocity distributions

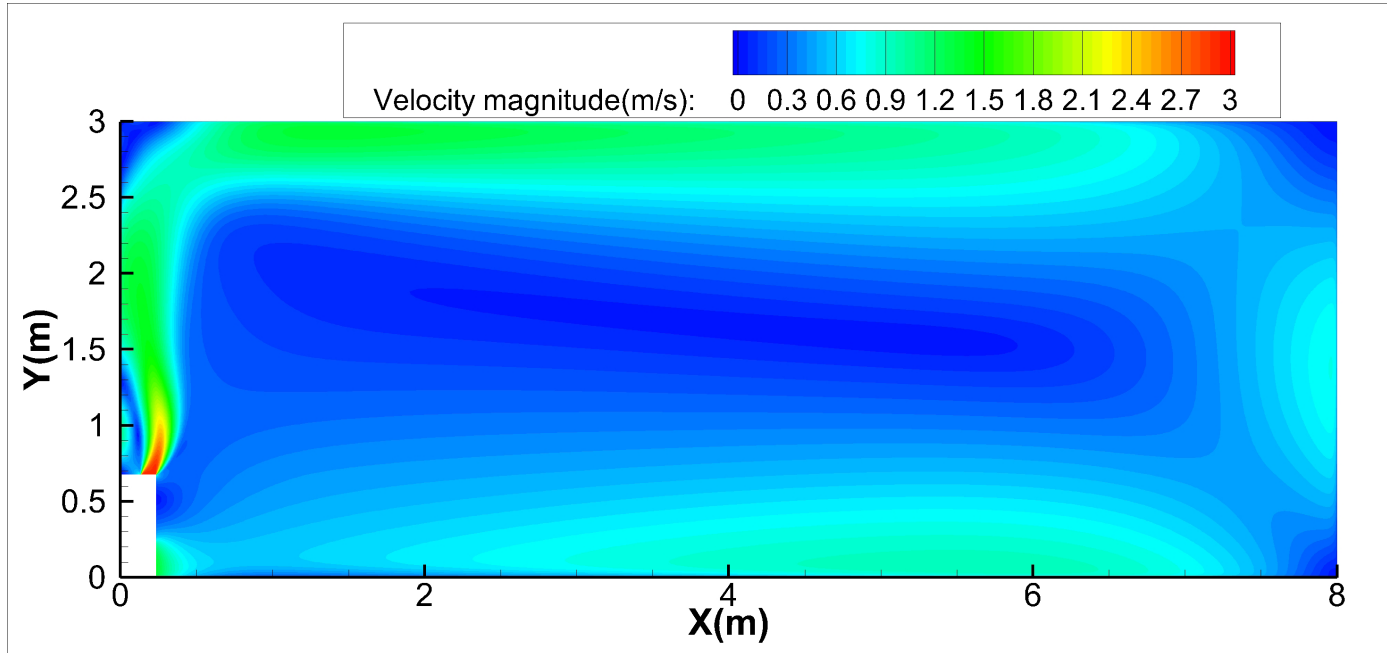

Heating temperature distributions

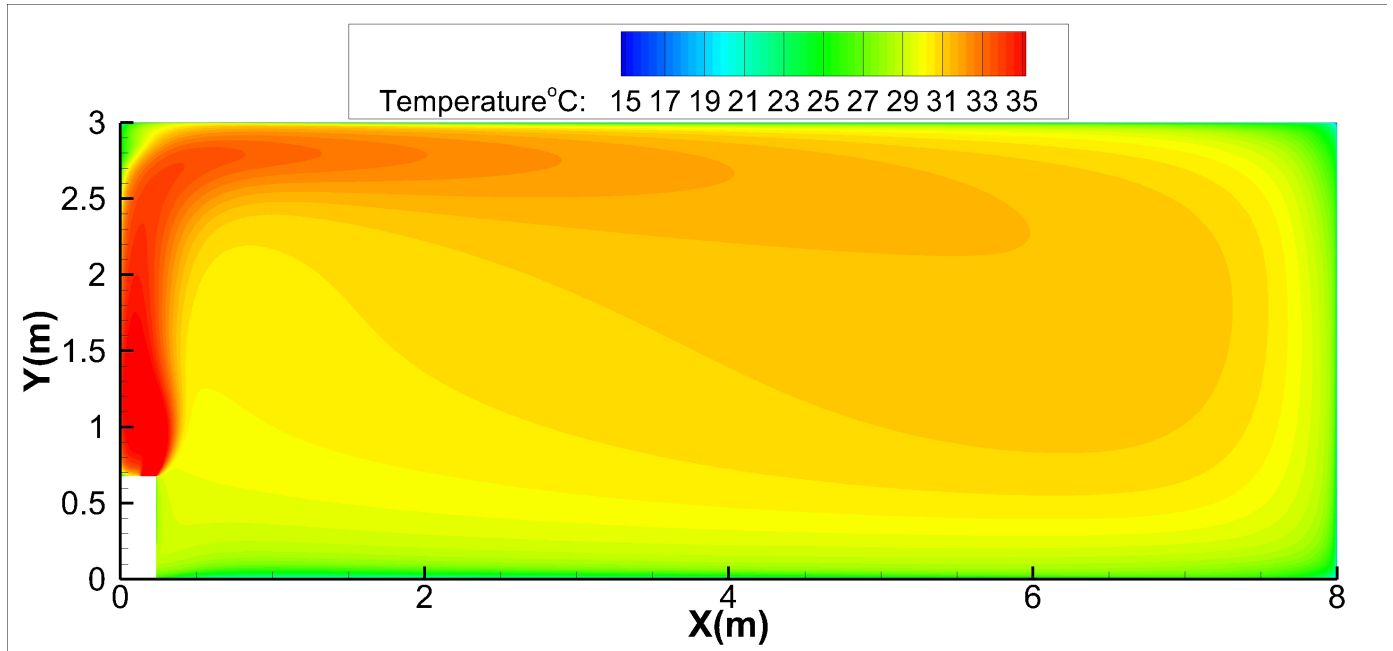

Floor Ceiling Type -24k

Ceiling installation:

Discharge Angle 30°

Cooling airflow velocity distributions

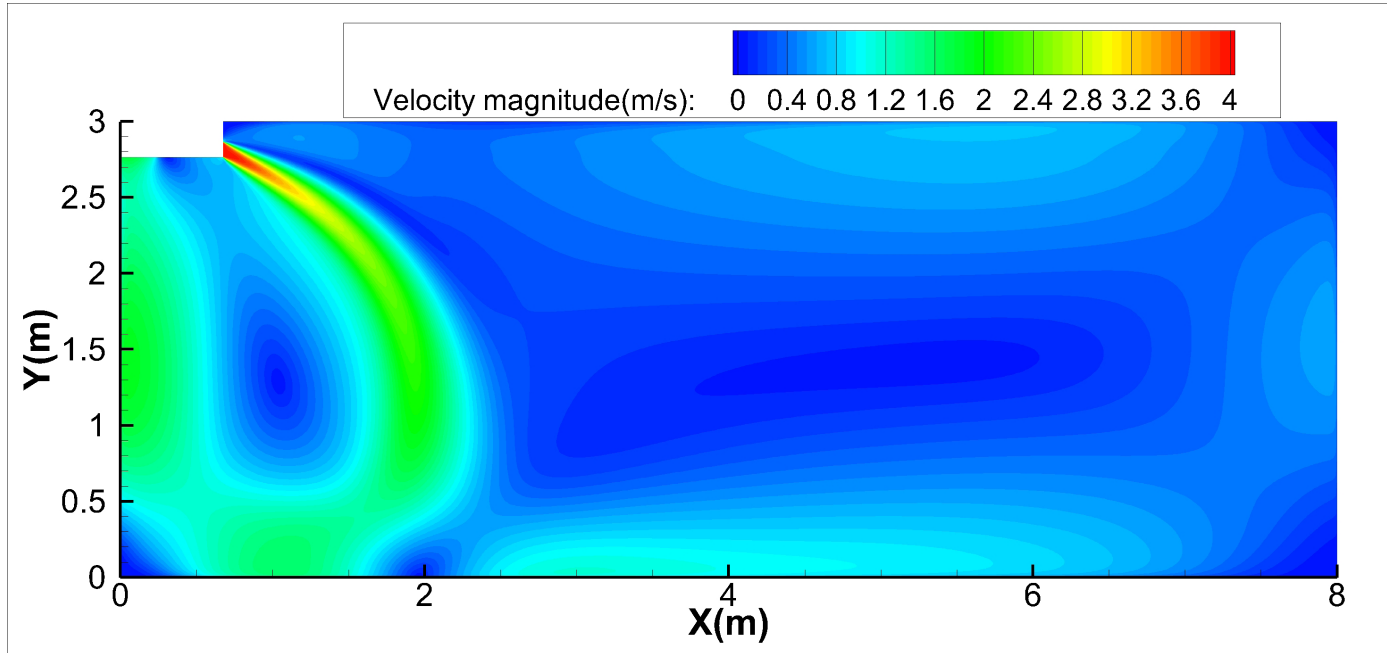

Specifications

Cooling temperature distributions

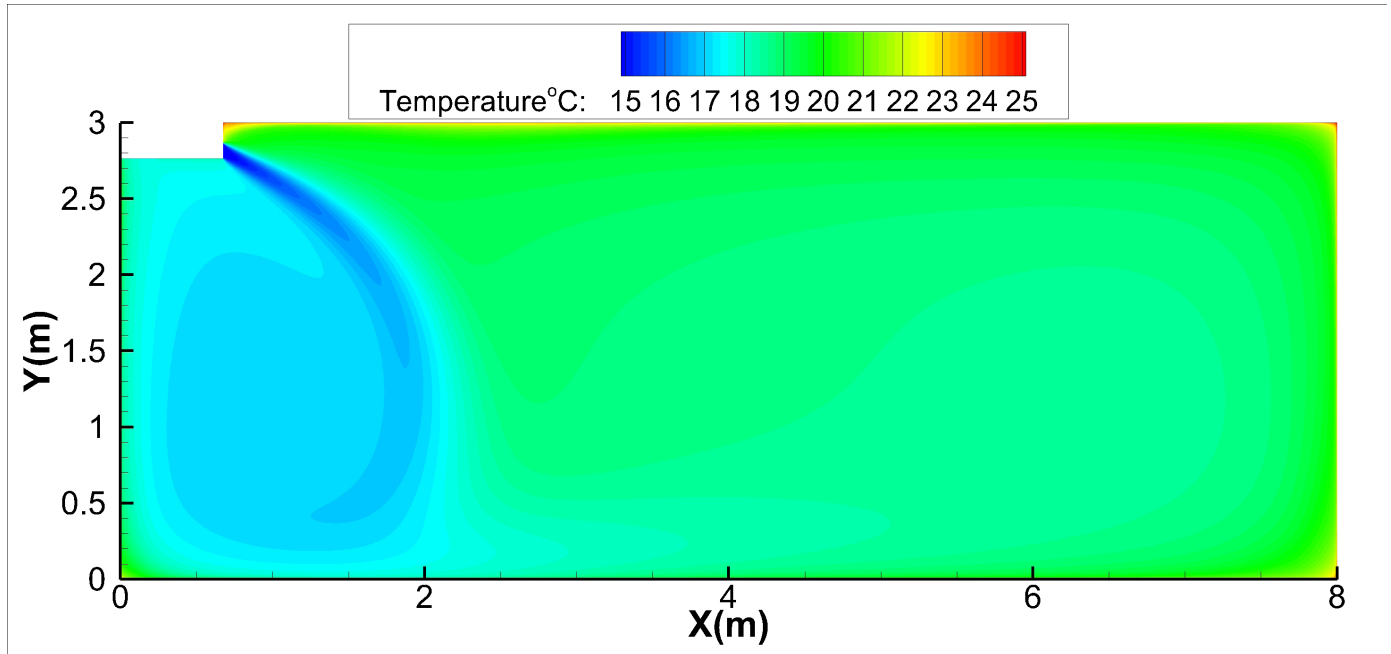

Floor Ceiling Type -24k

Ceiling installation:

Discharge Angle 60°

Cooling airflow velocity distributions

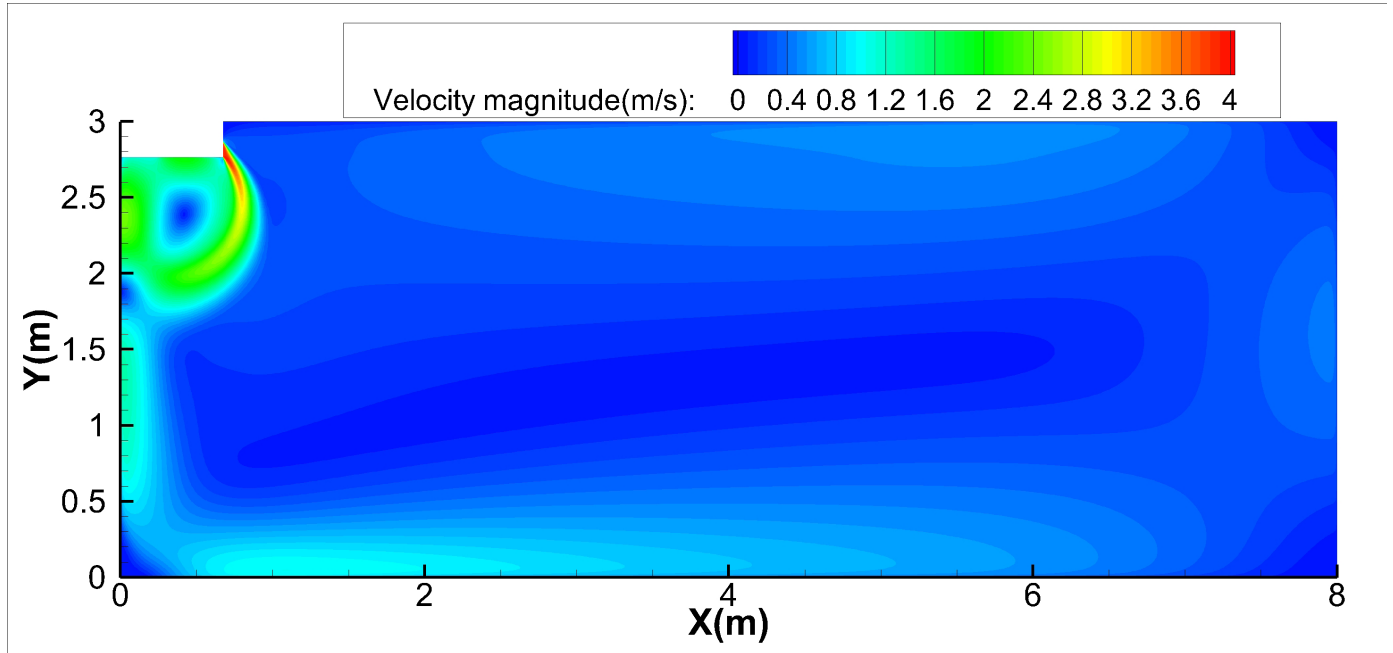

Cooling temperature distributions

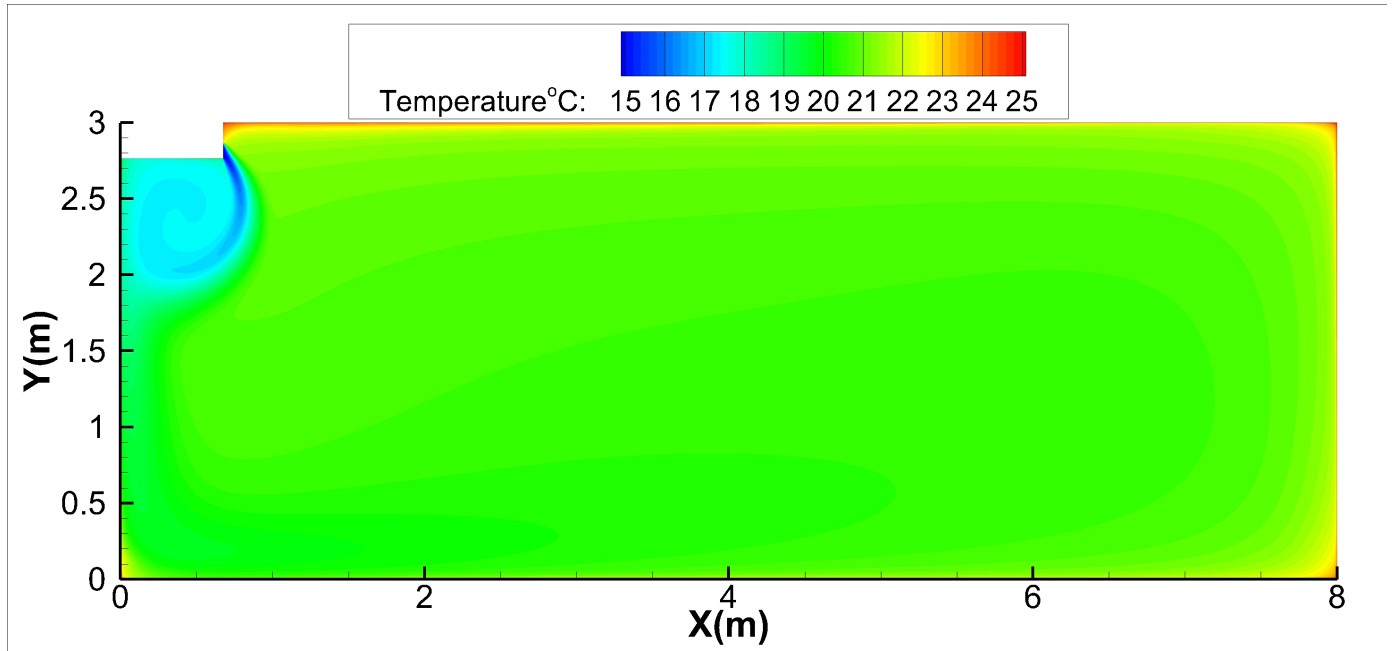

Floor Ceiling Type -24k

Ceiling installation:

Discharge Angle 30°

Heating airflow velocity distributions

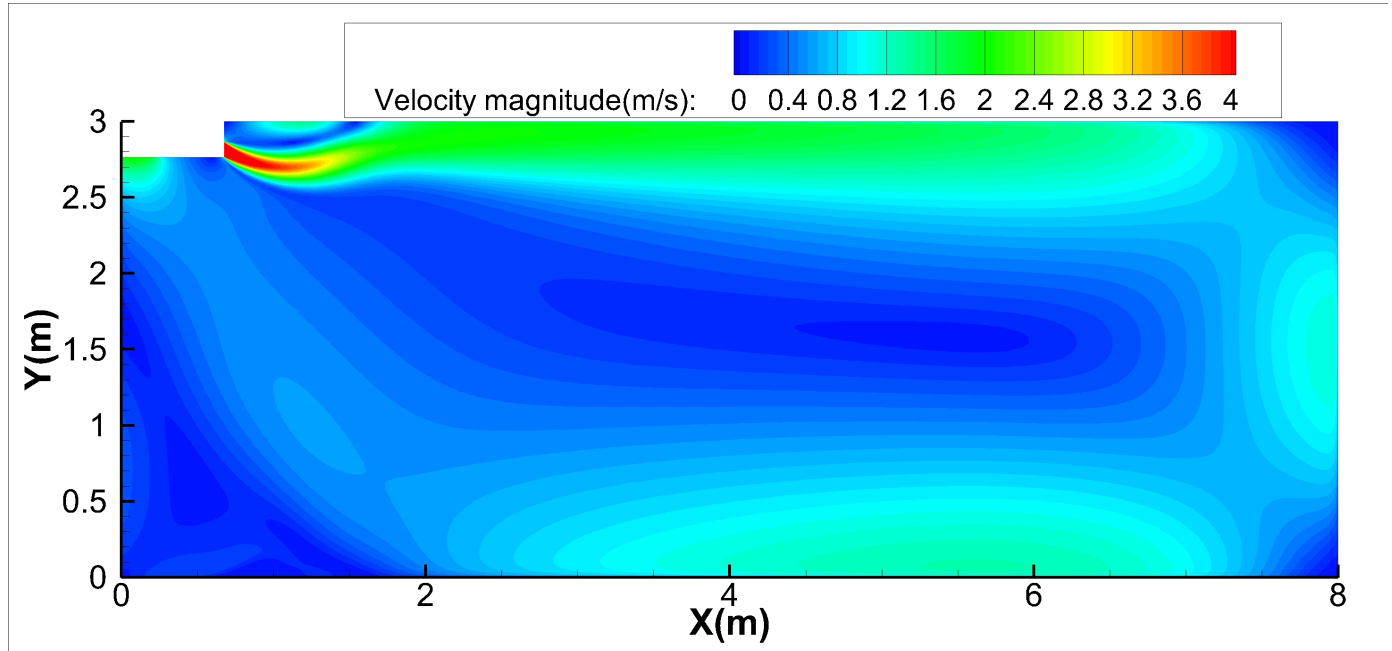

Specifications

Heating temperature distributions

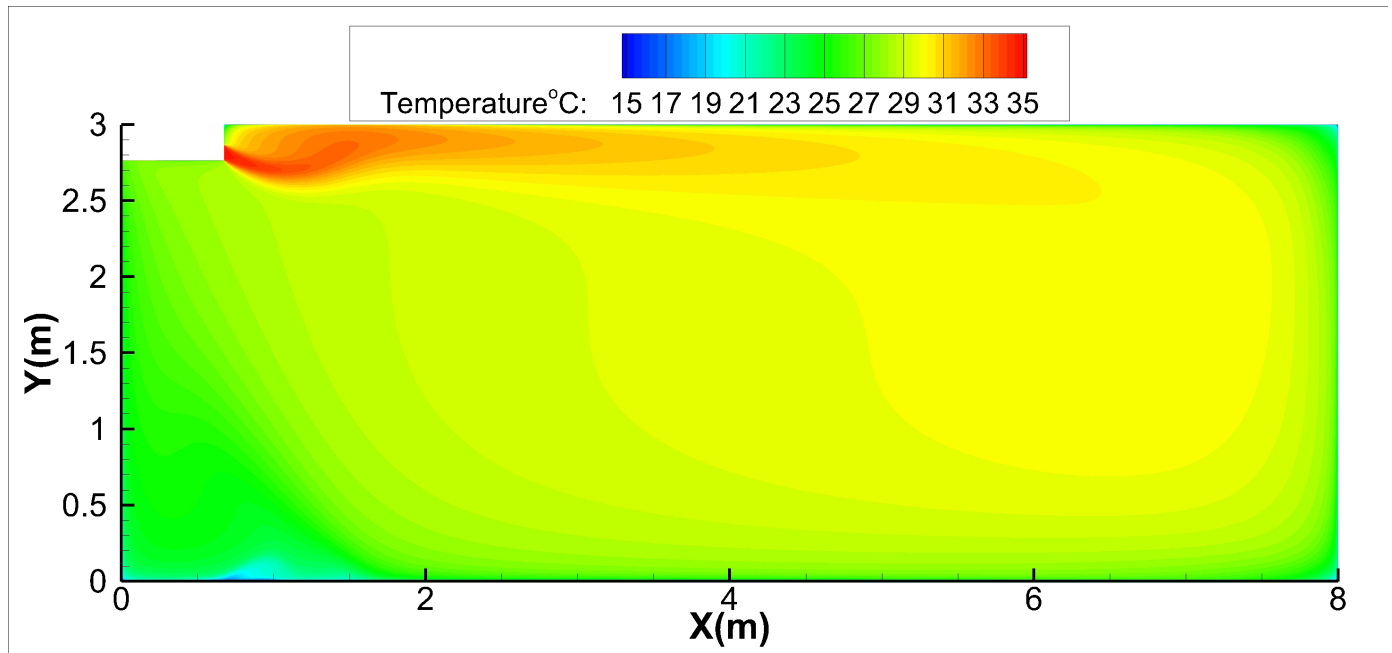

Floor Ceiling Type -24k

Ceiling installation:

Discharge Angle 60°

Heating airflow velocity distributions

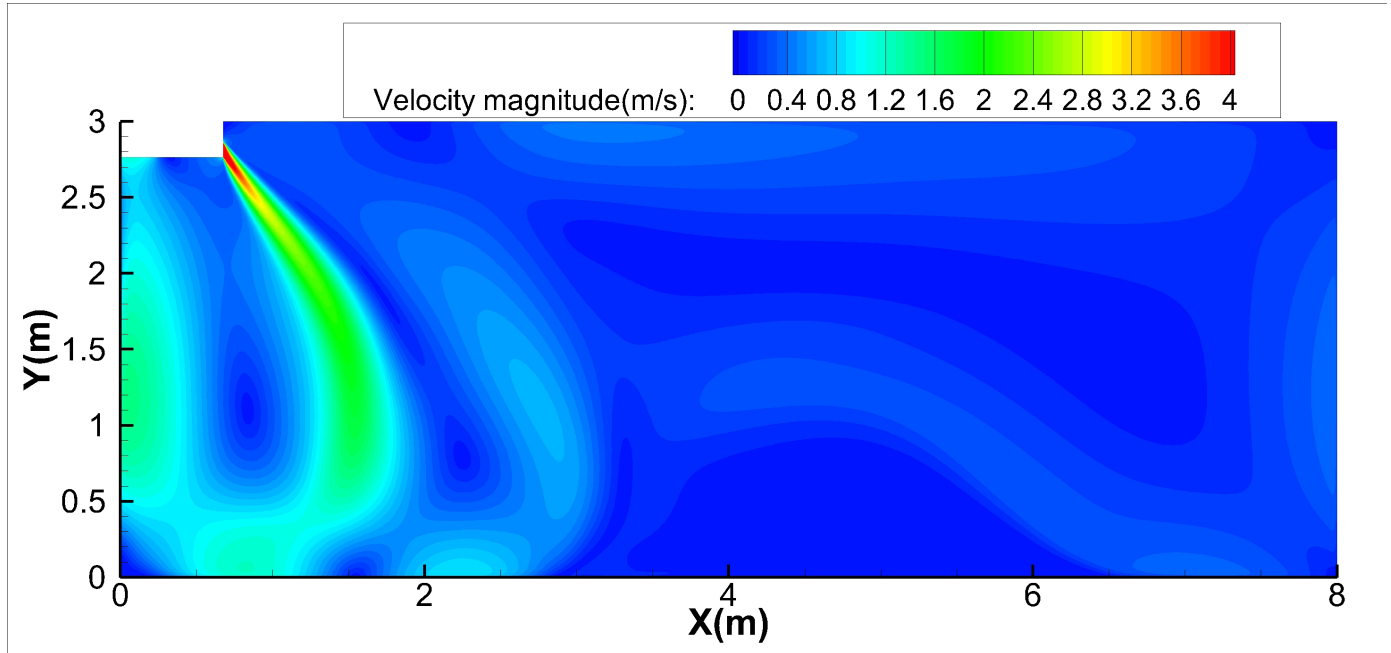

Heating temperature distributions

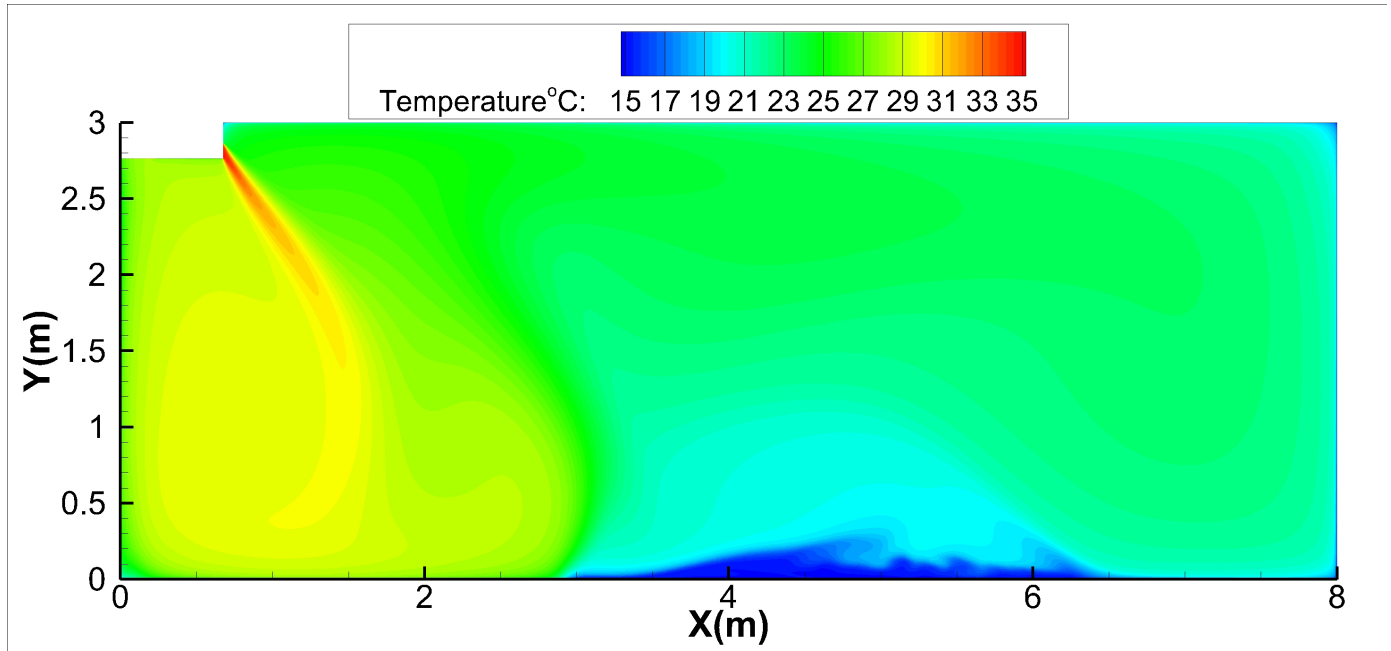

Floor Ceiling Type -24k

Floor installation:

Discharge Angle 30°

Cooling airflow velocity distributions

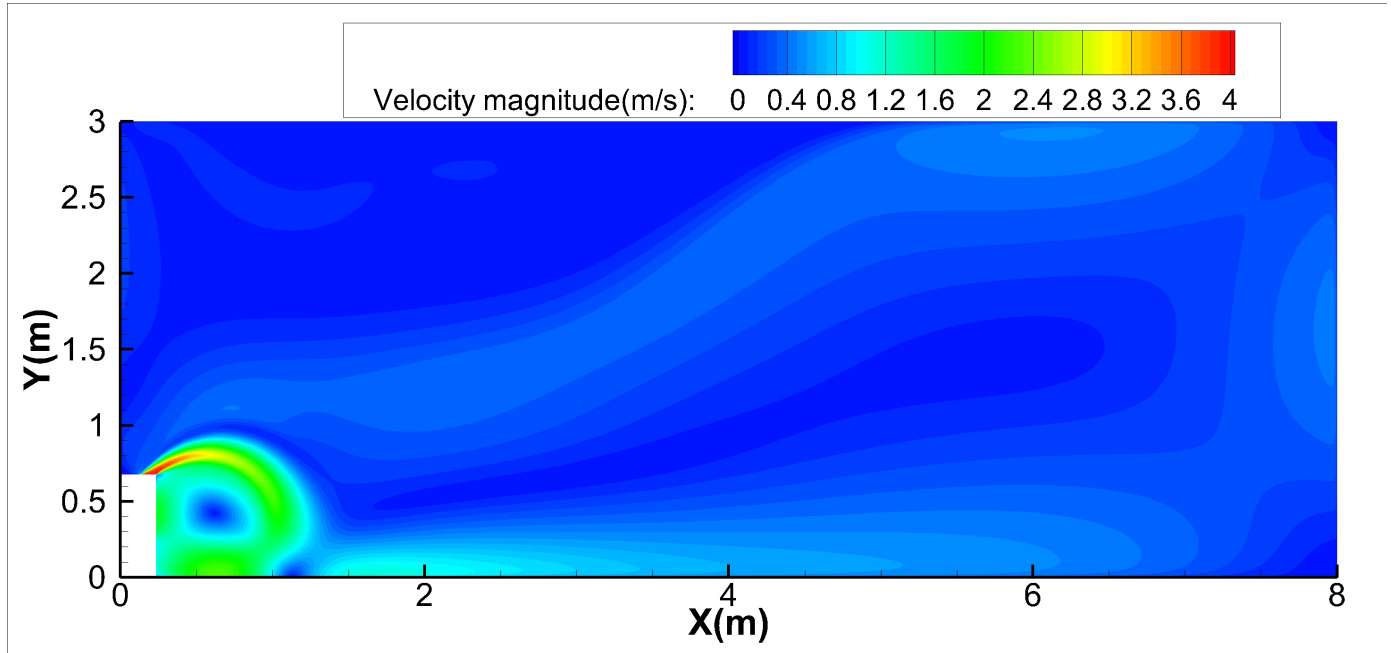

Specifications

Cooling temperature distributions

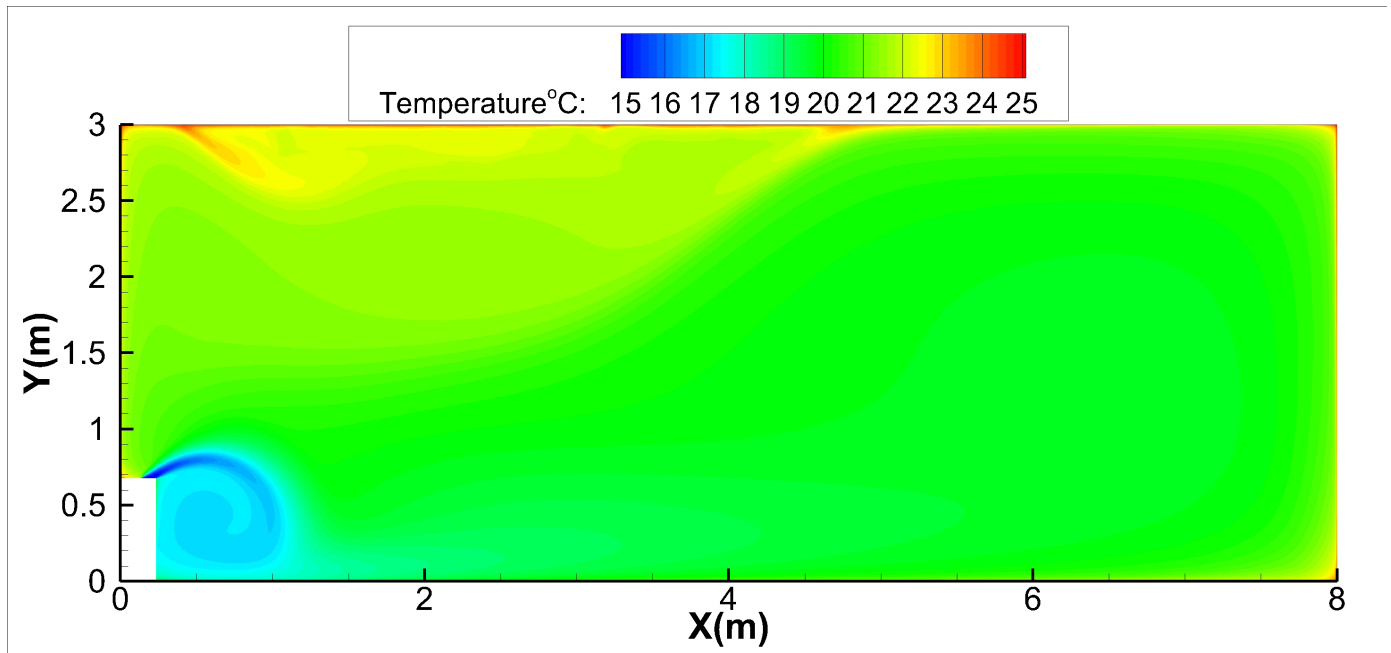

Floor Ceiling Type -24k

Floor installation:

Discharge Angle 60°

Cooling airflow velocity distributions

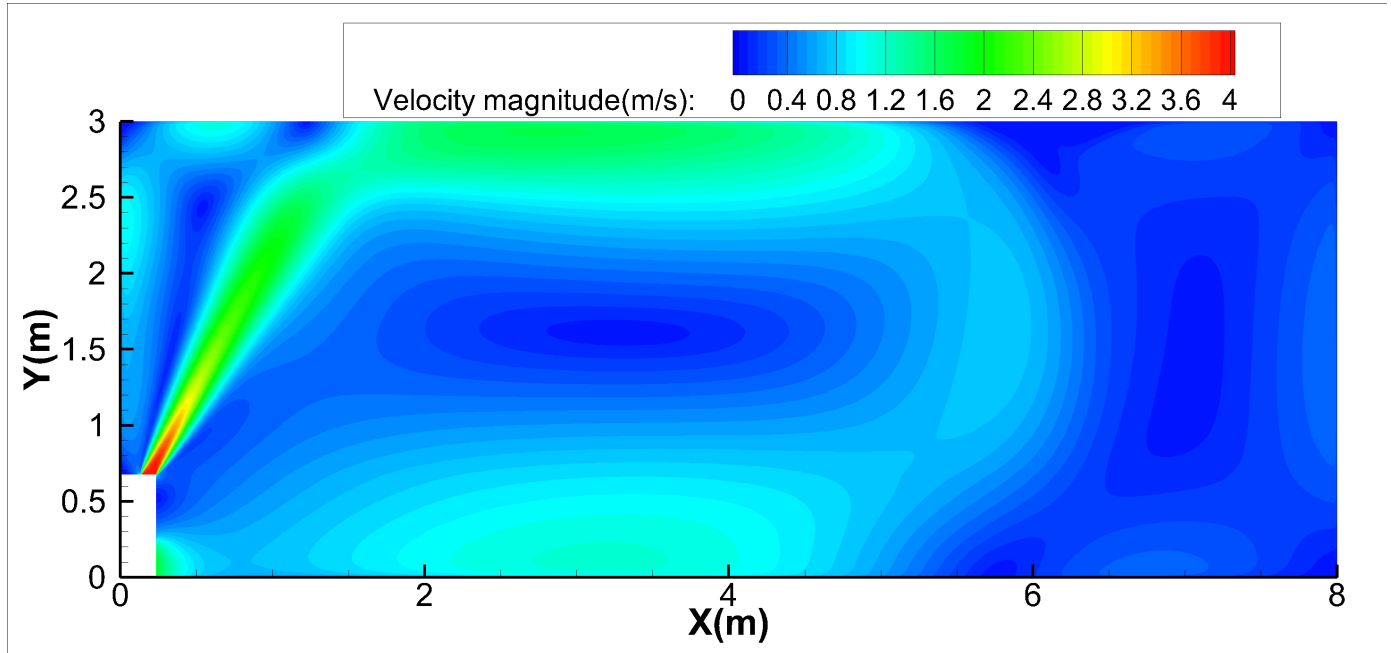

Cooling temperature distributions

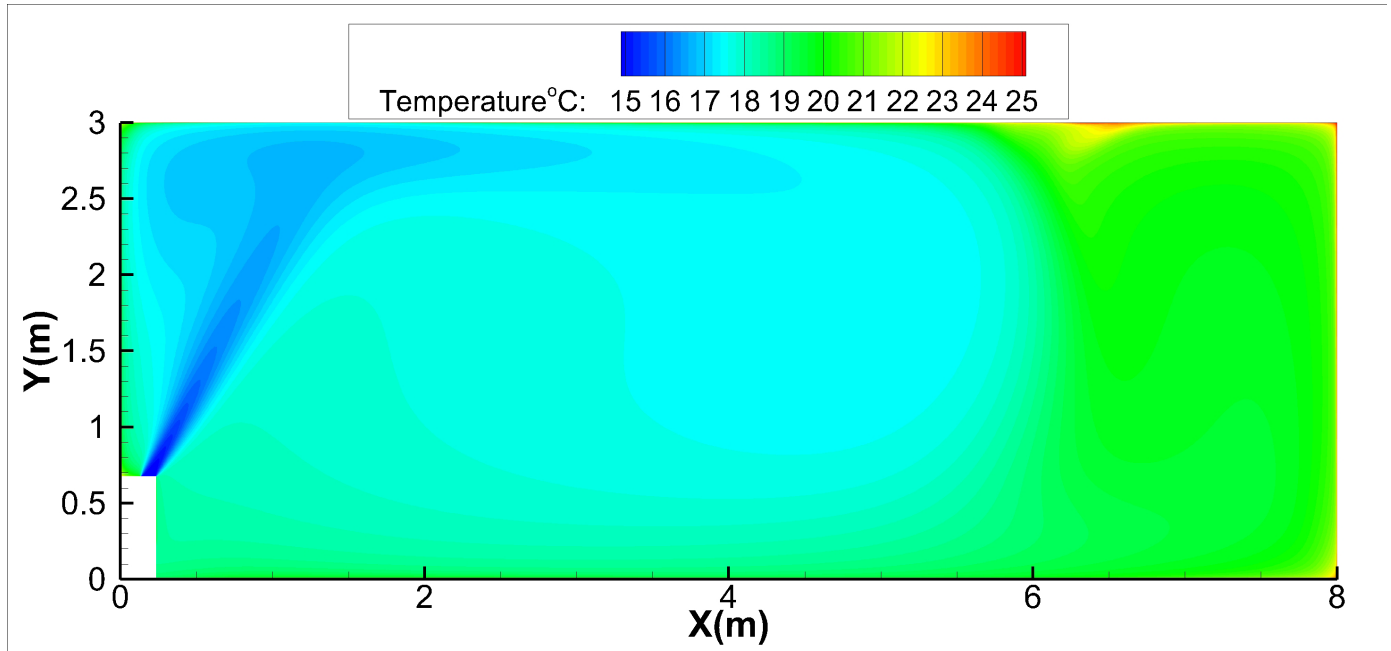

Floor Ceiling Type -24k

Floor installation:

Discharge Angle 30°

Heating airflow velocity distributions

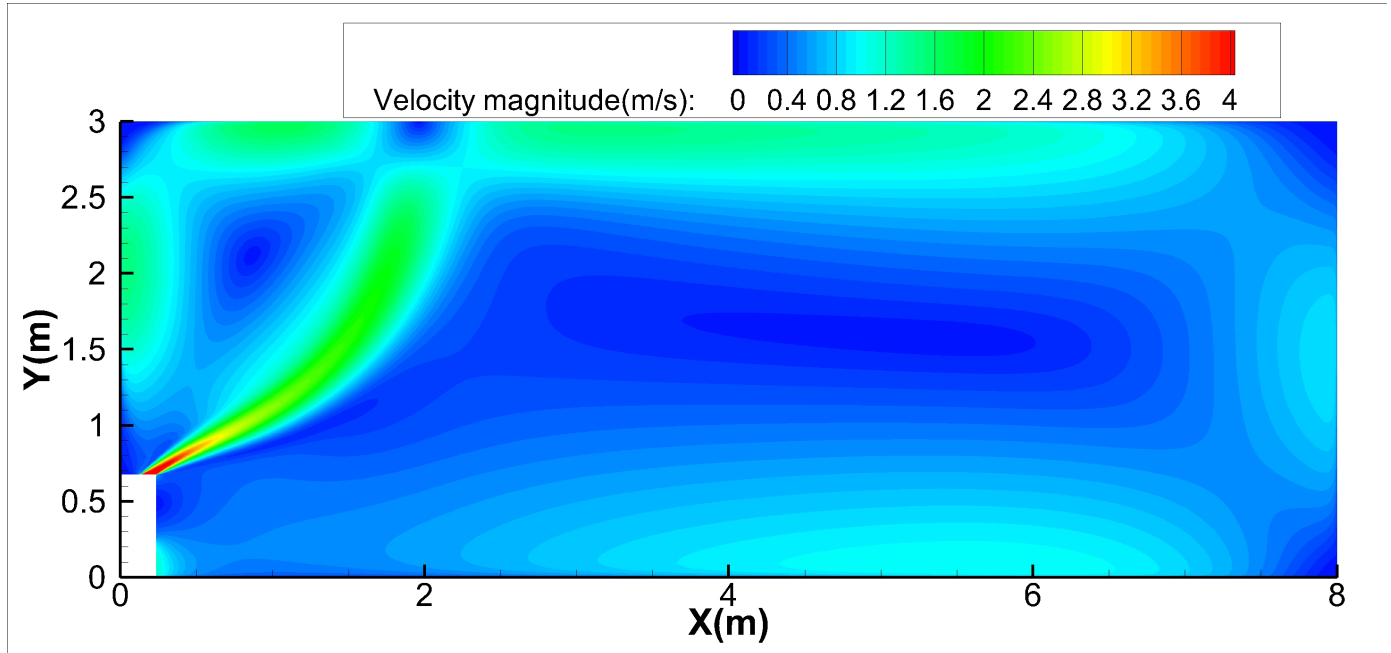

Specifications

Heating temperature distributions

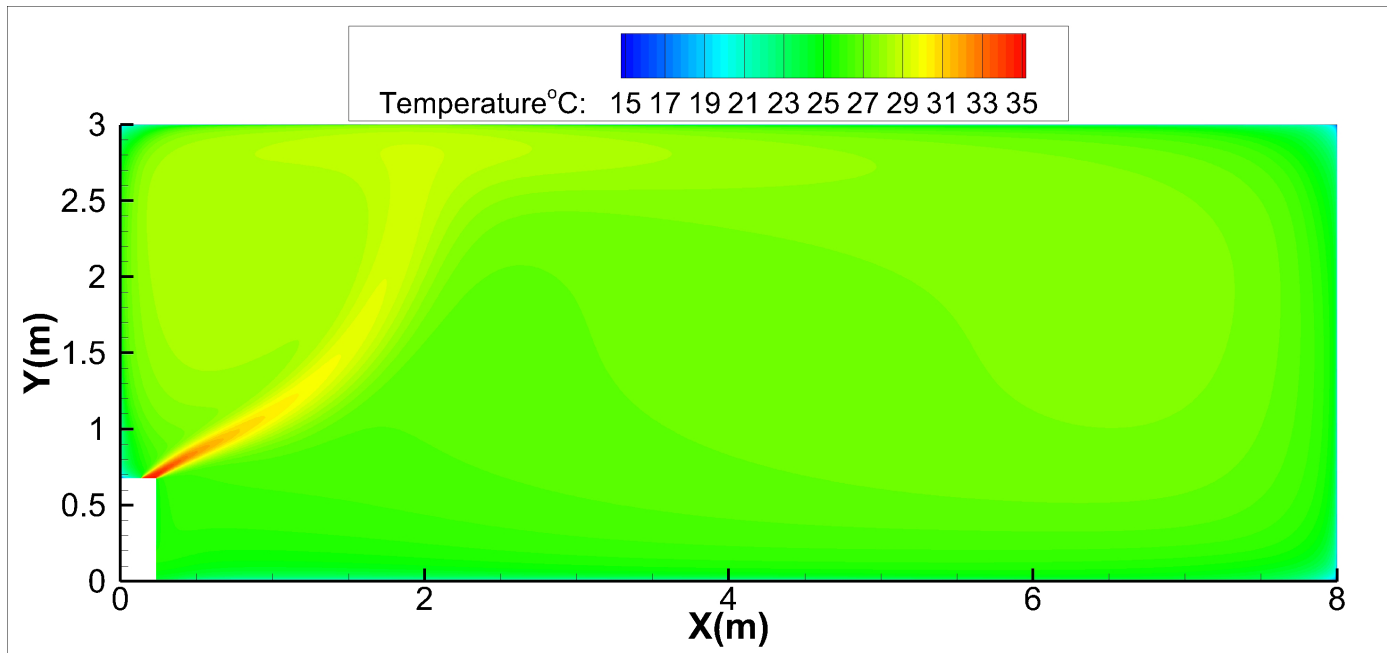

Floor Ceiling Type -24k

Floor installation:

Discharge Angle 60°

Heating airflow velocity distributions

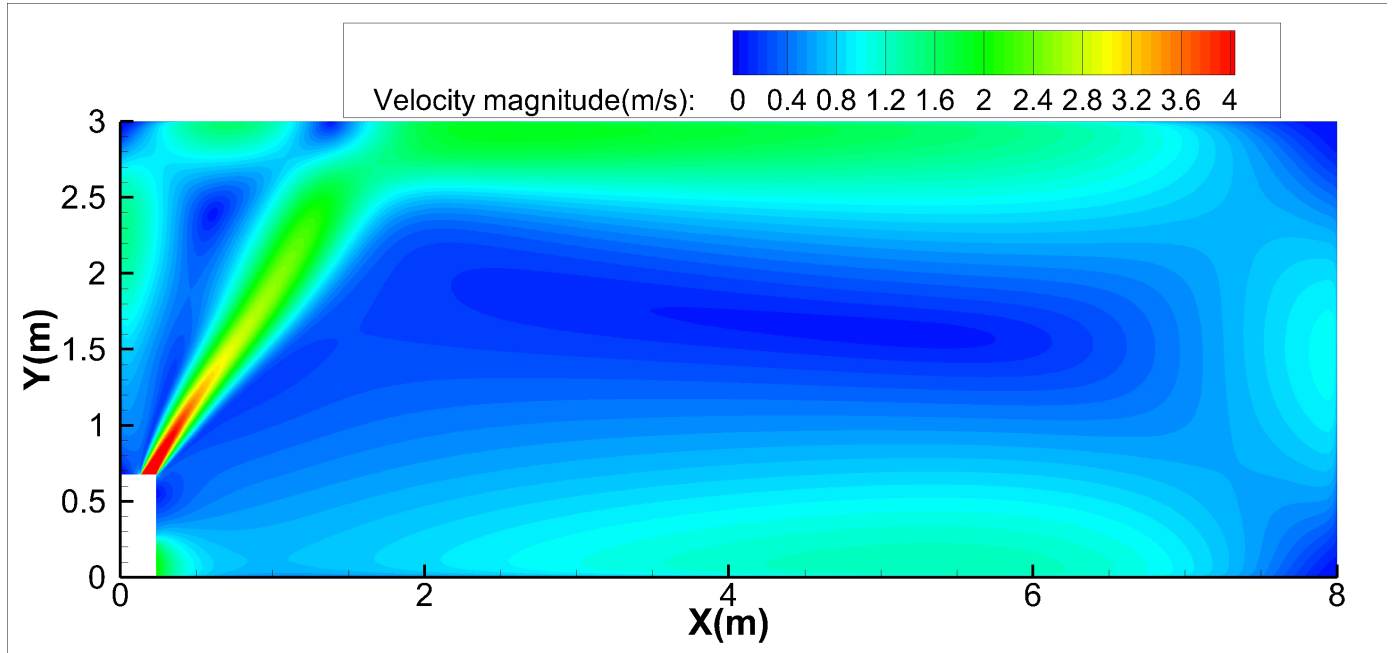

Heating temperature distributions

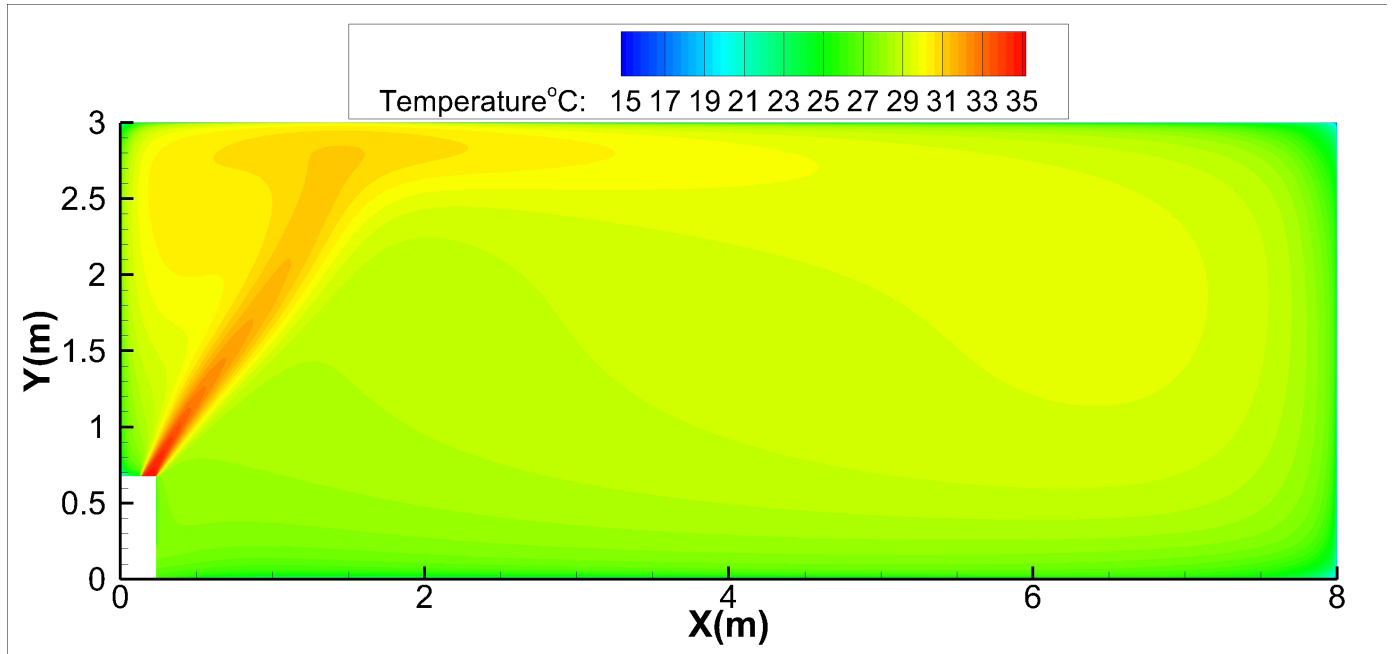

Infini-6k&9k

Cooling(ID: 27°C/80.6°F, OD: 35°C/95°F)

Discharge Angle 58°

Airflow velocity distributions

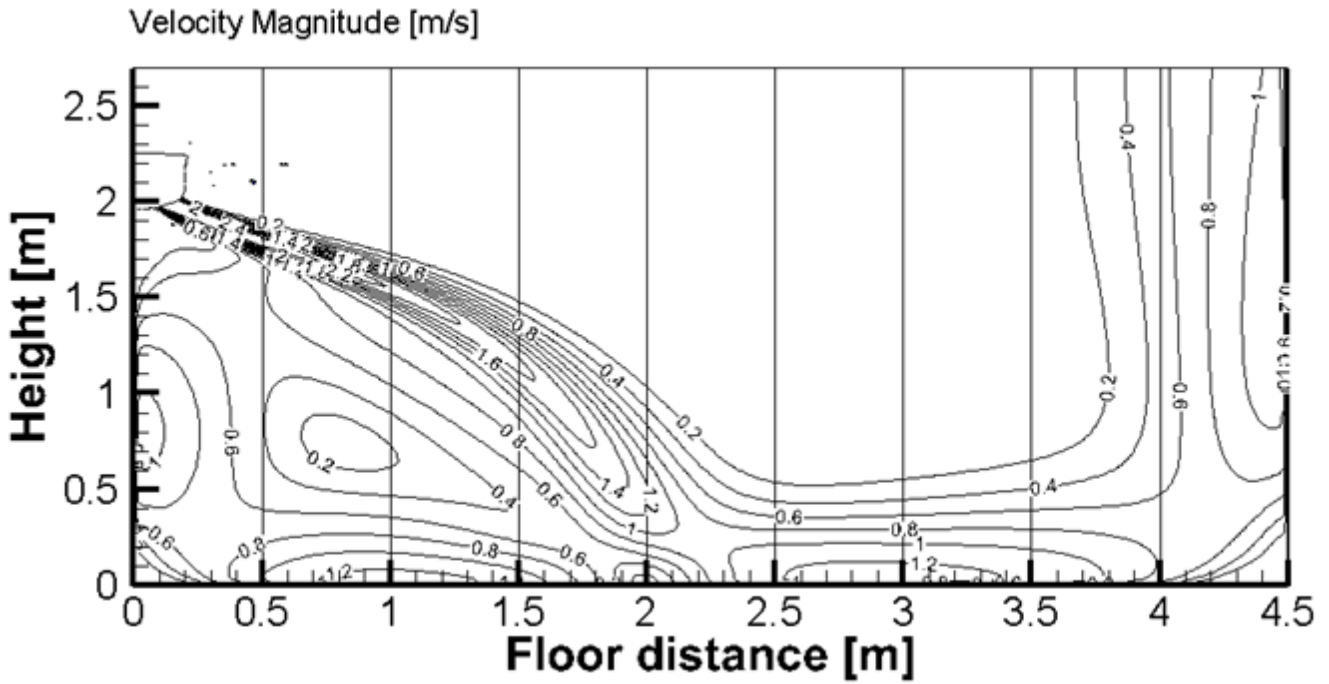

Temperature distributions

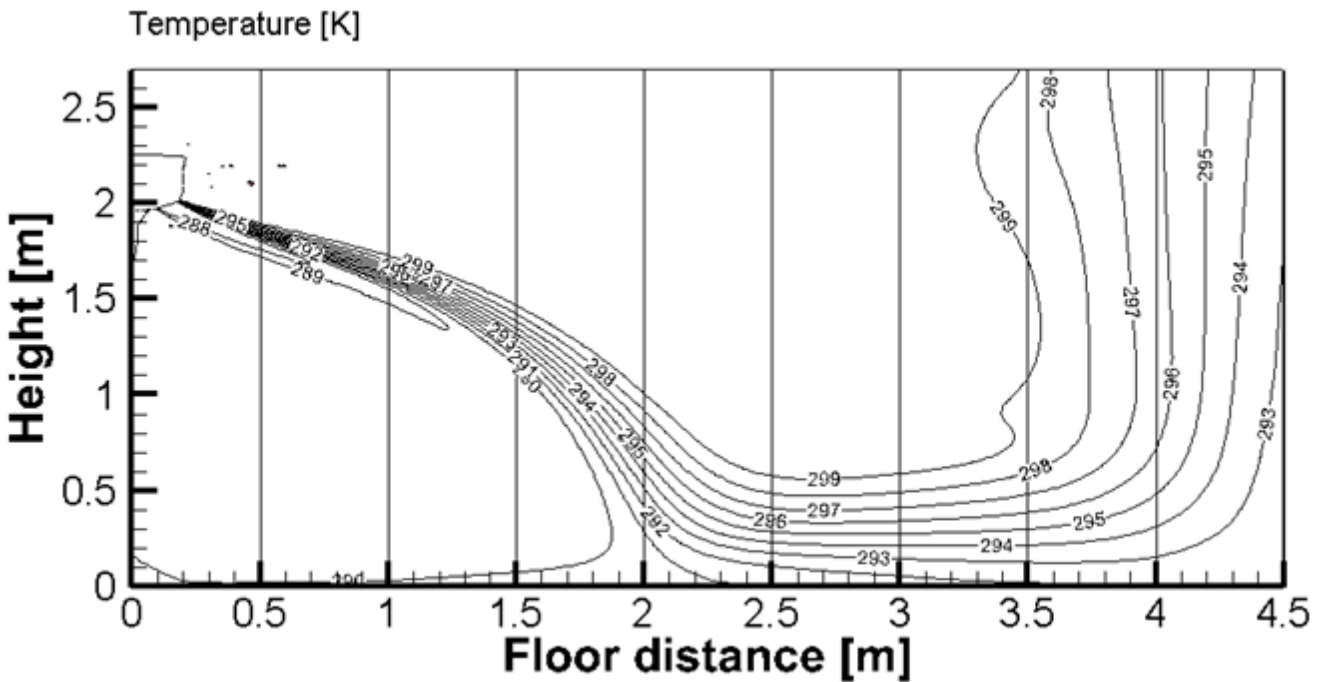

Infini-6k&9k

Heating(ID: 20°C/68°F, OD: 7°C/44.6°F)

Discharge Angle 90°

Airflow velocity distributions

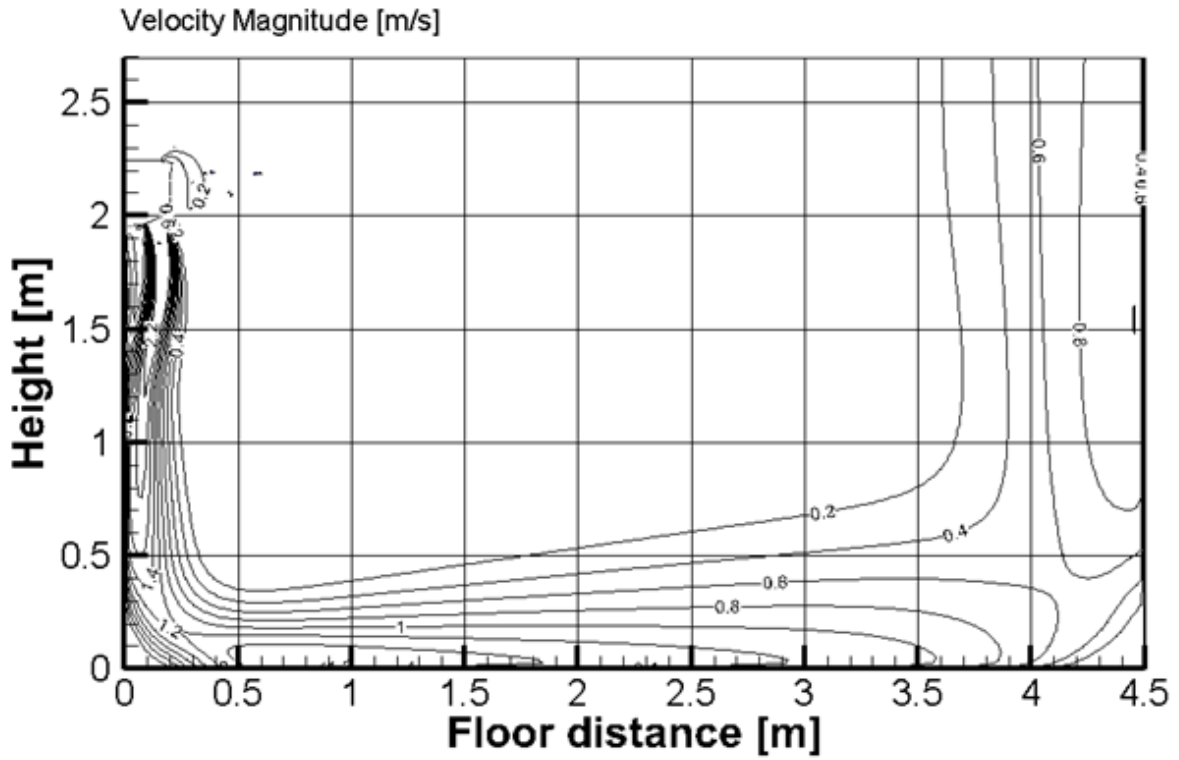

Temperature distributions

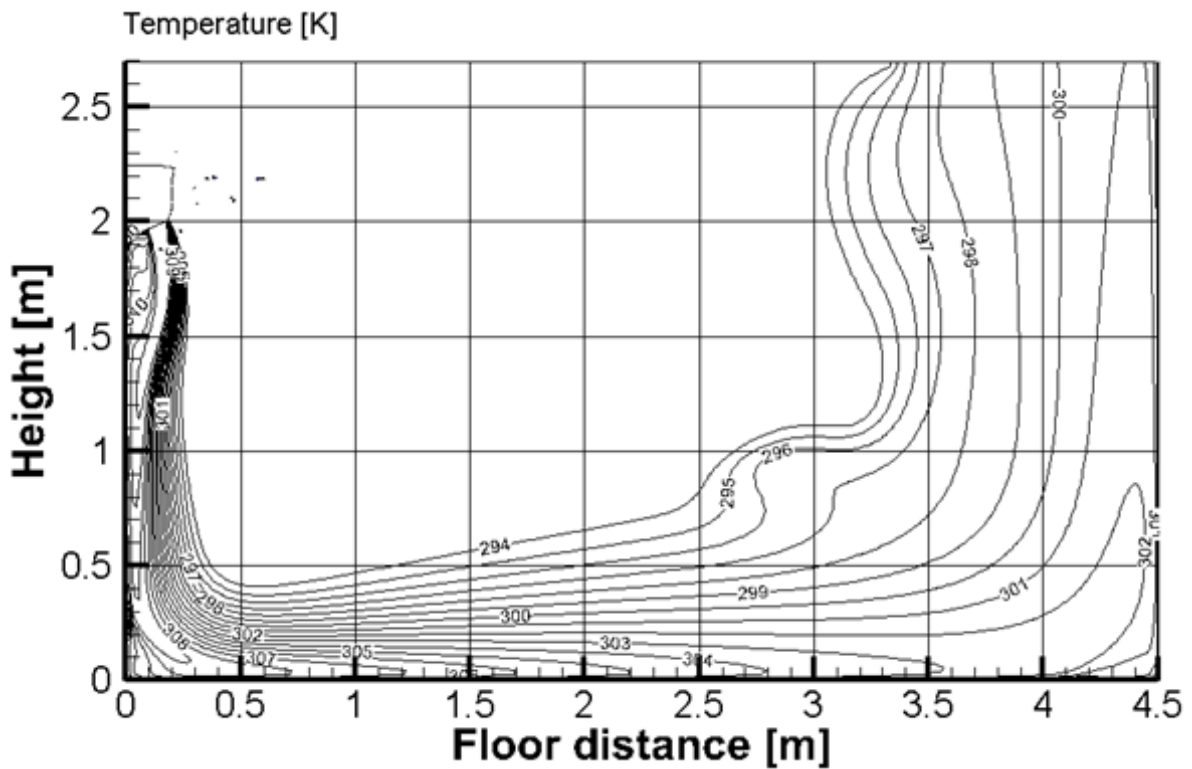

Infini-12k

Cooling(ID: 27°C/80.6°F, OD: 35°C/95°F)

Discharge Angle 58°

Airflow velocity distributions

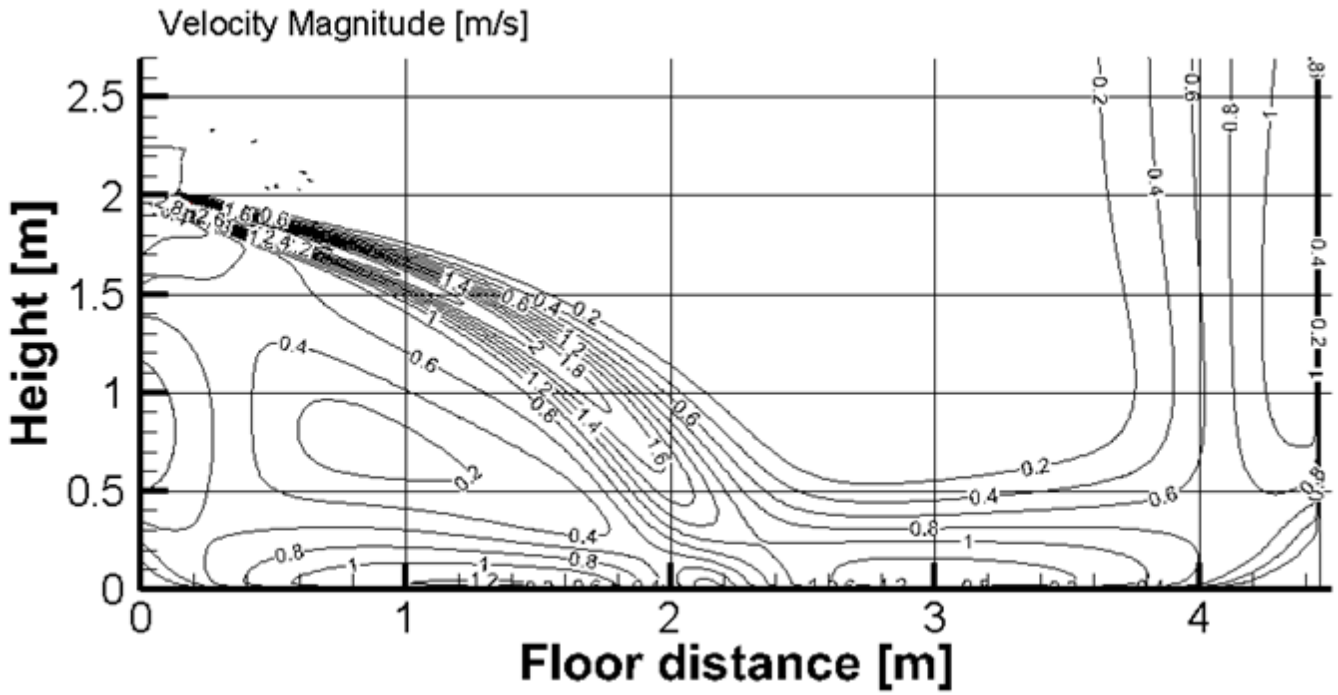

Specifications

Temperature distributions

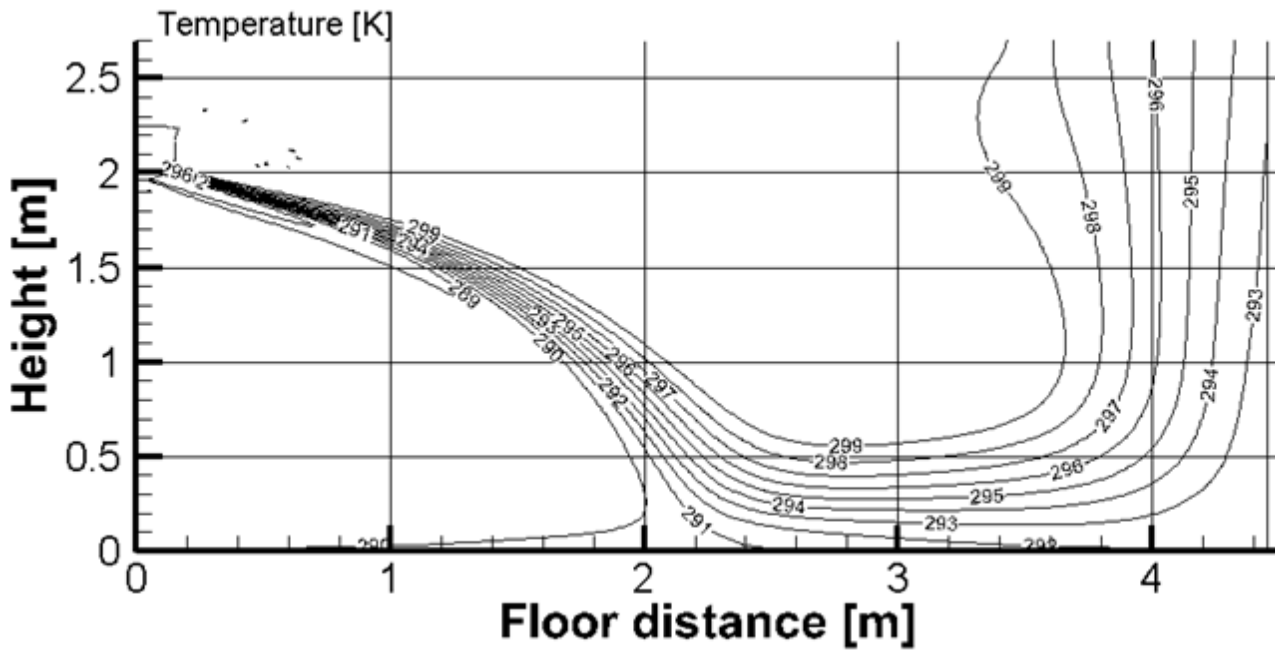

Infini-12k

Heating(ID: 20°C/68°F, OD: 7°C/44.6°F)

Discharge Angle 90°

Airflow velocity distributions

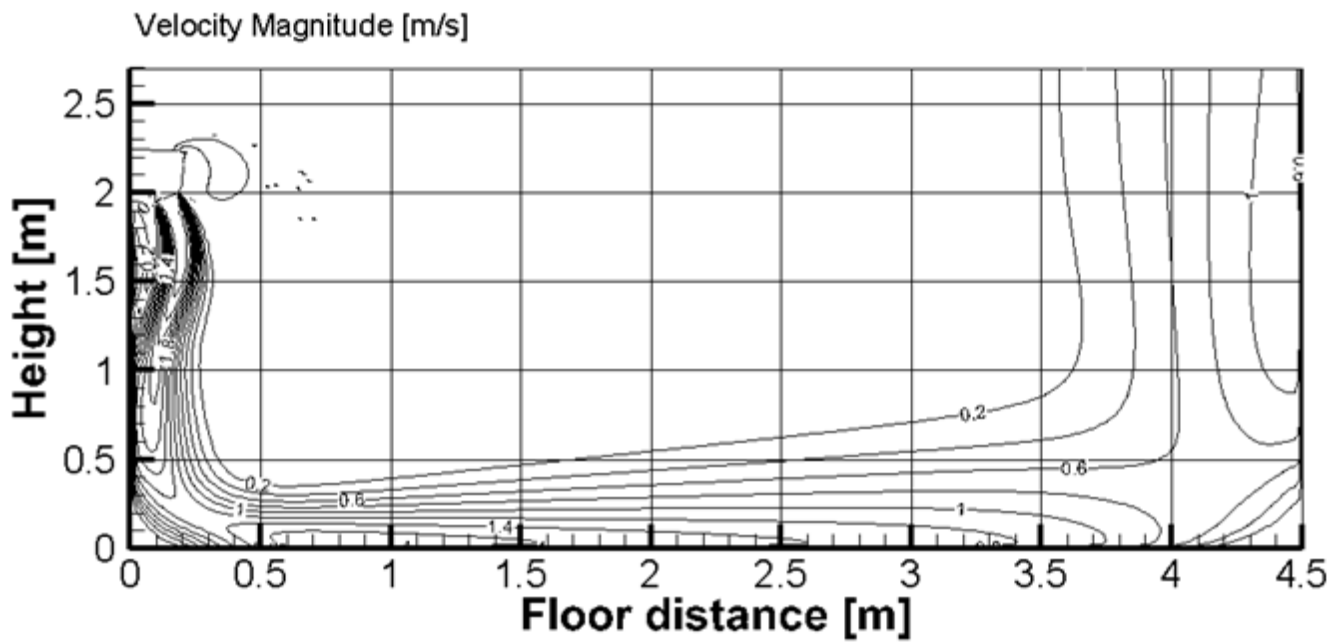

Temperature distributions

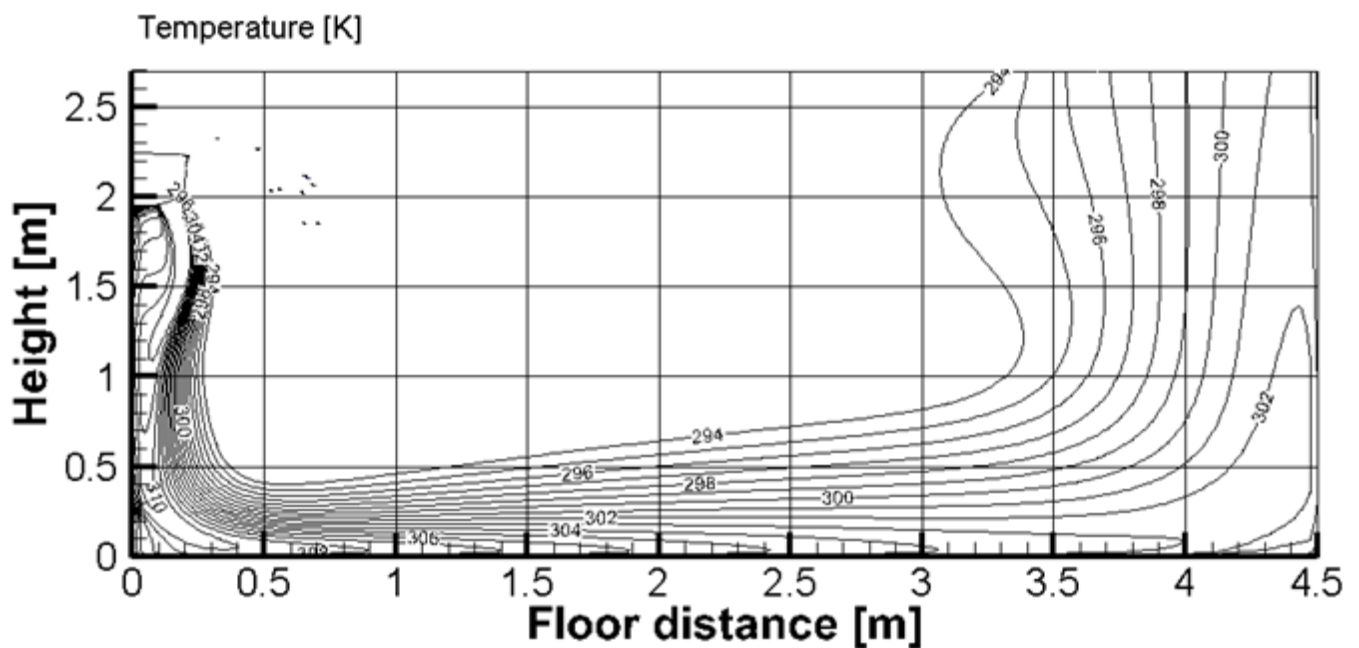

Infini-18k

Cooling(ID: 27°C/80.6°F, OD: 35°C/95°F)

Discharge Angle 50°

Airflow velocity distributions

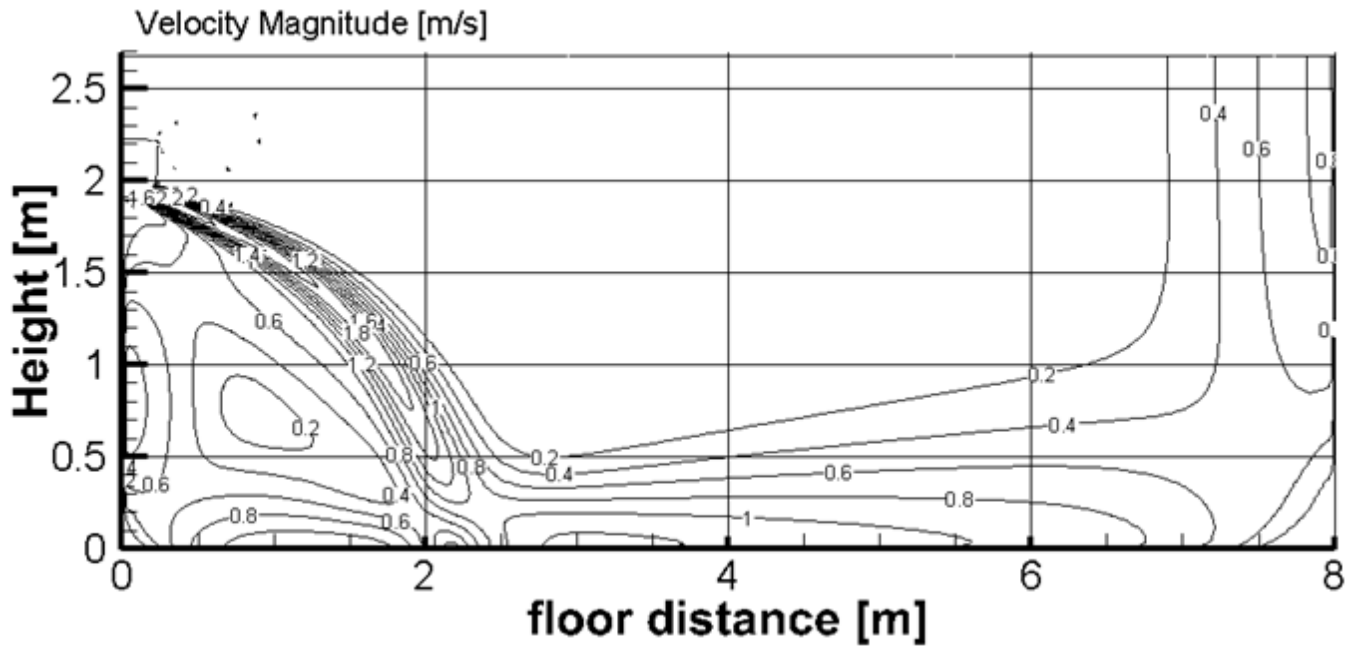

Specifications

Temperature distributions

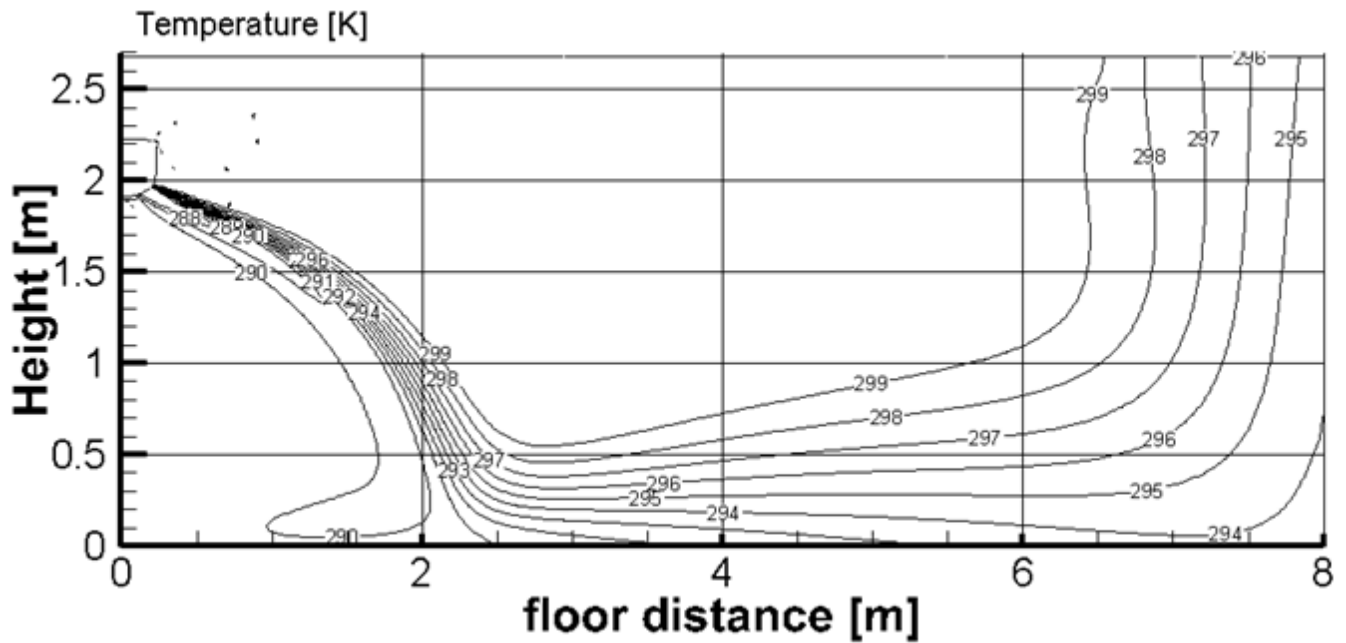

Infini-18k

Heating(ID: 20°C/68°F, OD: 7°C/44.6°F)

Discharge Angle 84°

Airflow velocity distributions

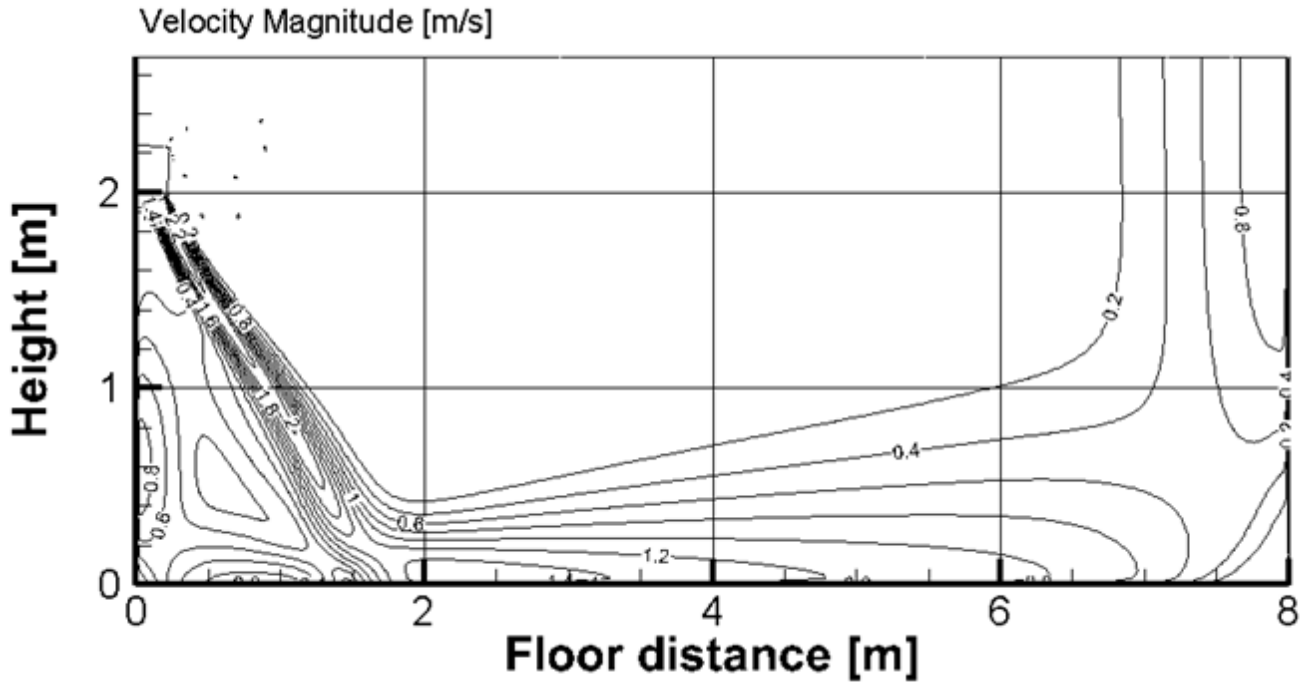

Temperature distributions

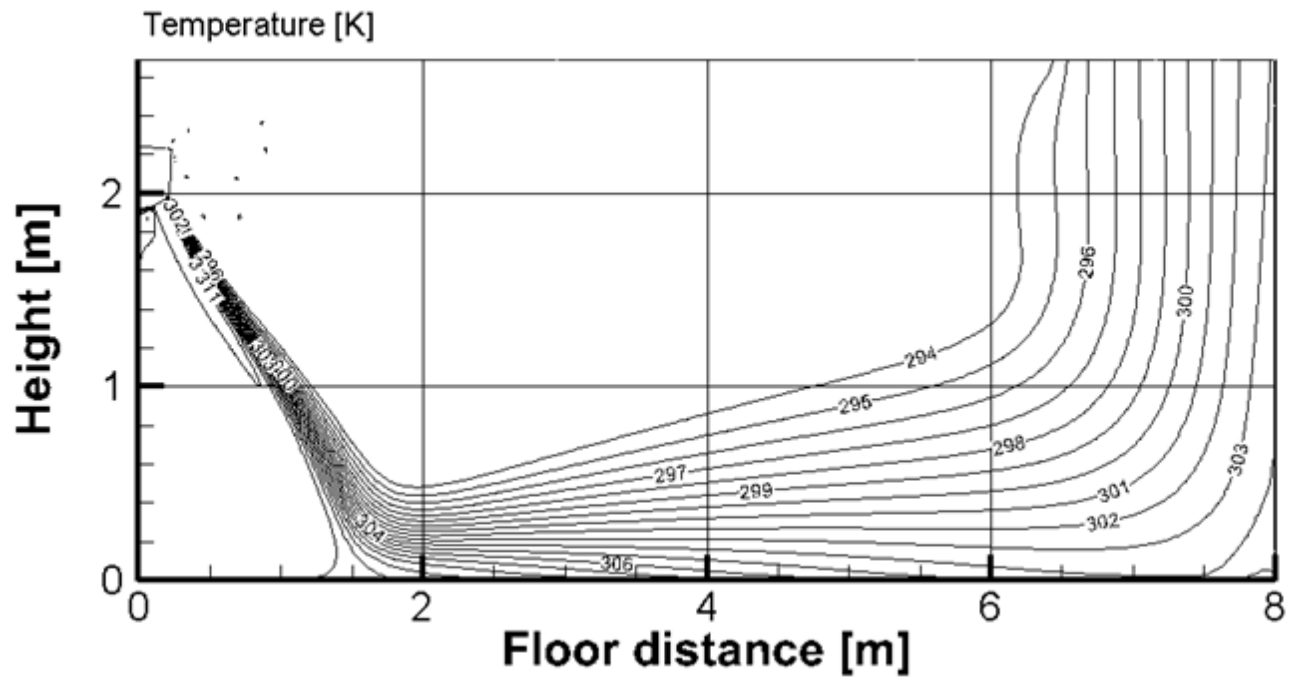

Infini-24k

Cooling(ID: 27°C/80.6°F, OD: 35°C/95°F)

Discharge Angle 50°

Airflow velocity distributions

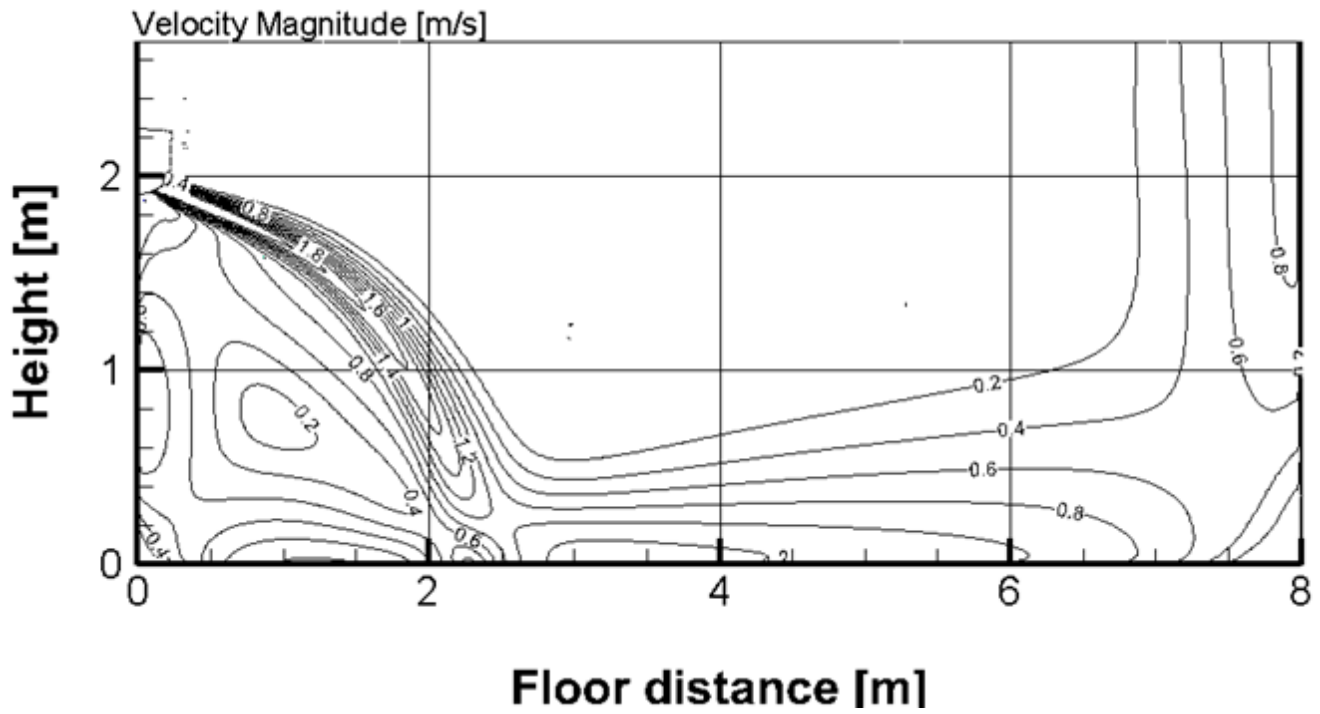

Temperature distributions

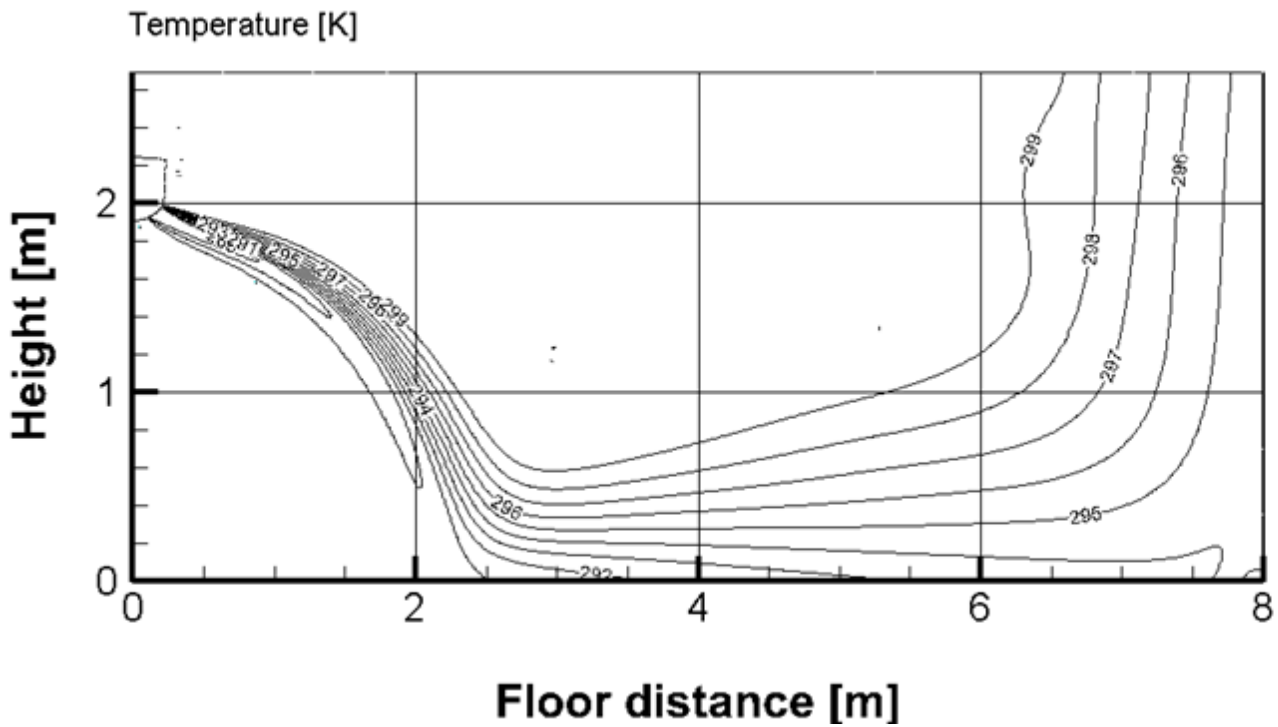

Infini-24k

Heating(ID: 20°C/68°F, OD: 7°C/44.6°F)

Discharge Angle 67°

Airflow velocity distributions

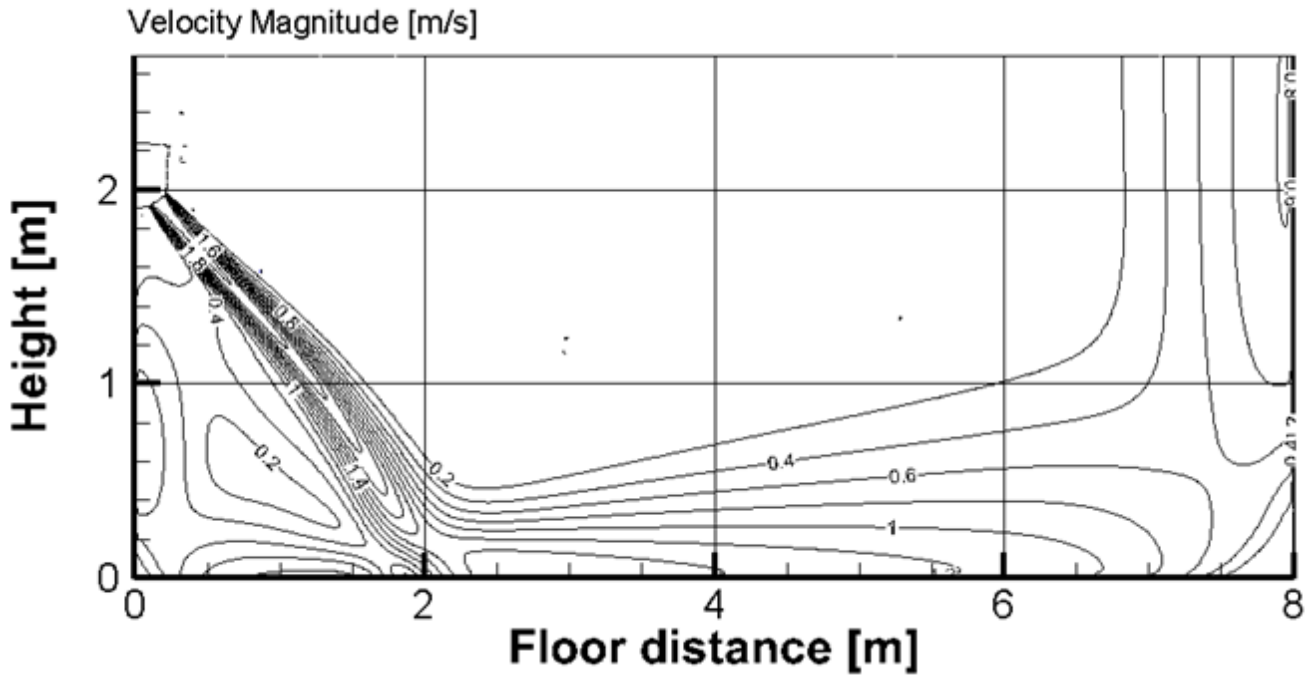

Temperature distributions

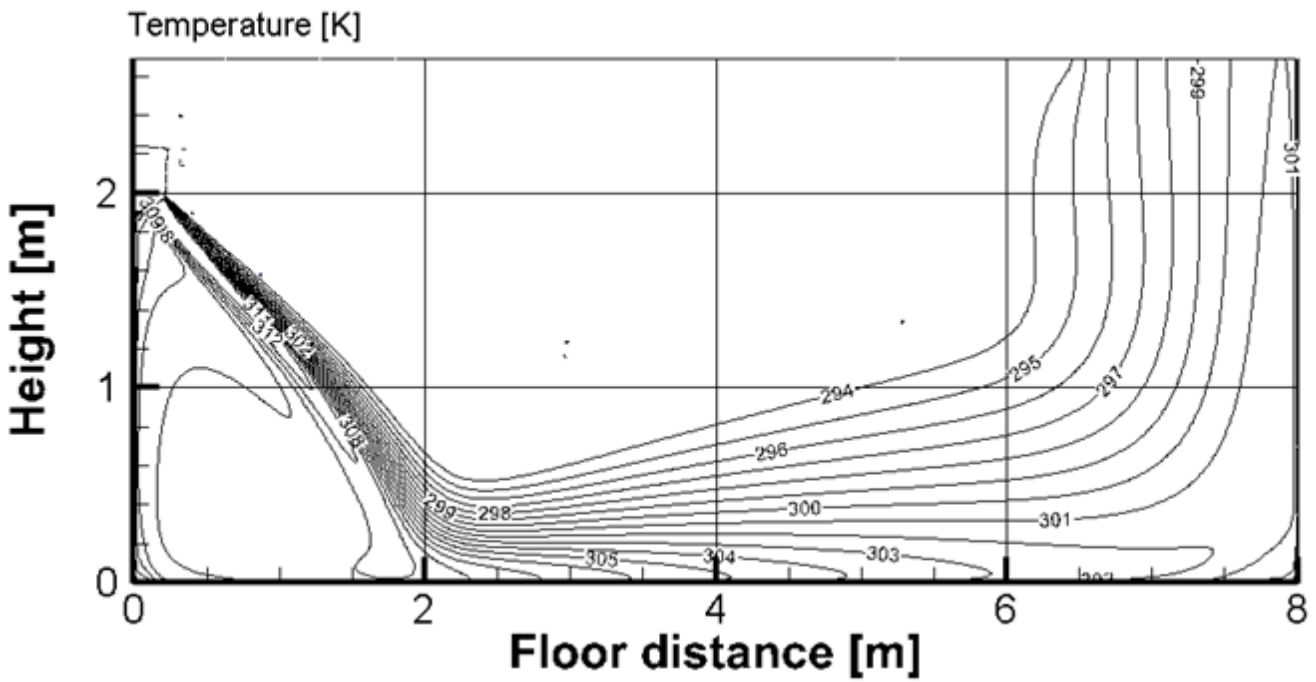

AURORA-9k

Cooling(ID: 27°C/80.6°F, OD: 35°C/95°F)

Discharge Angle 58°

Airflow velocity distributions

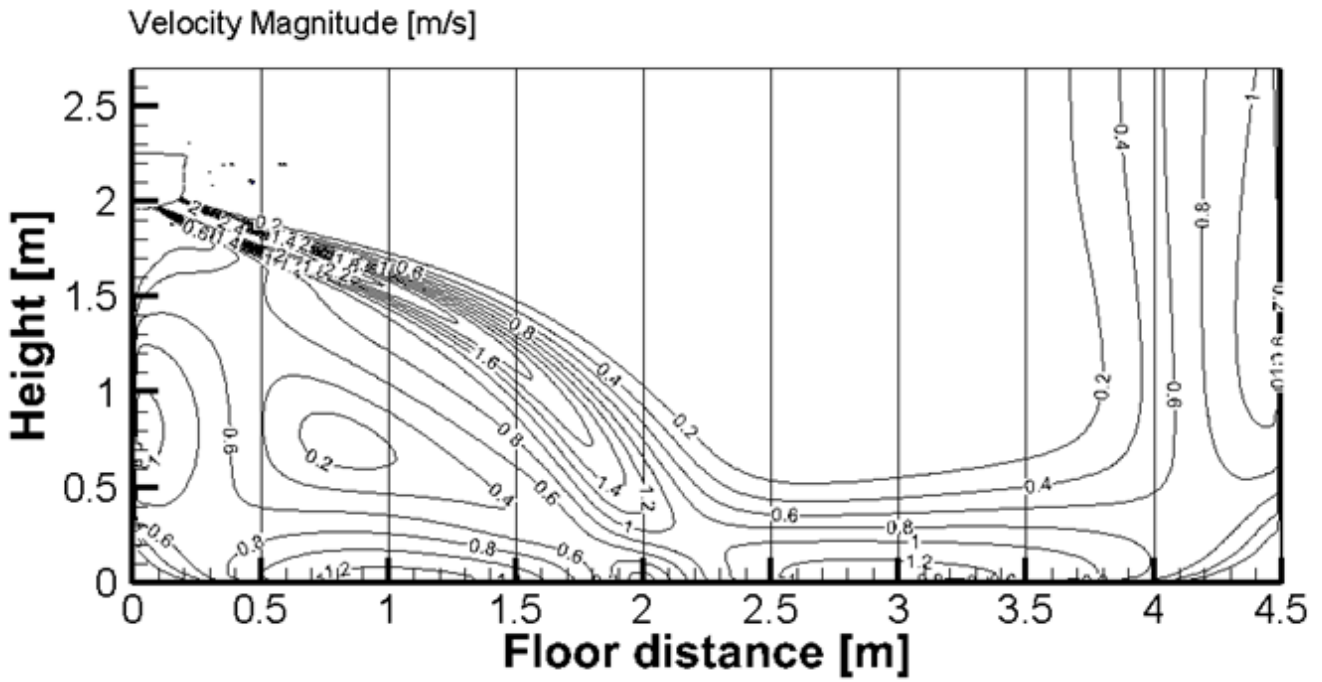

Temperature distributions

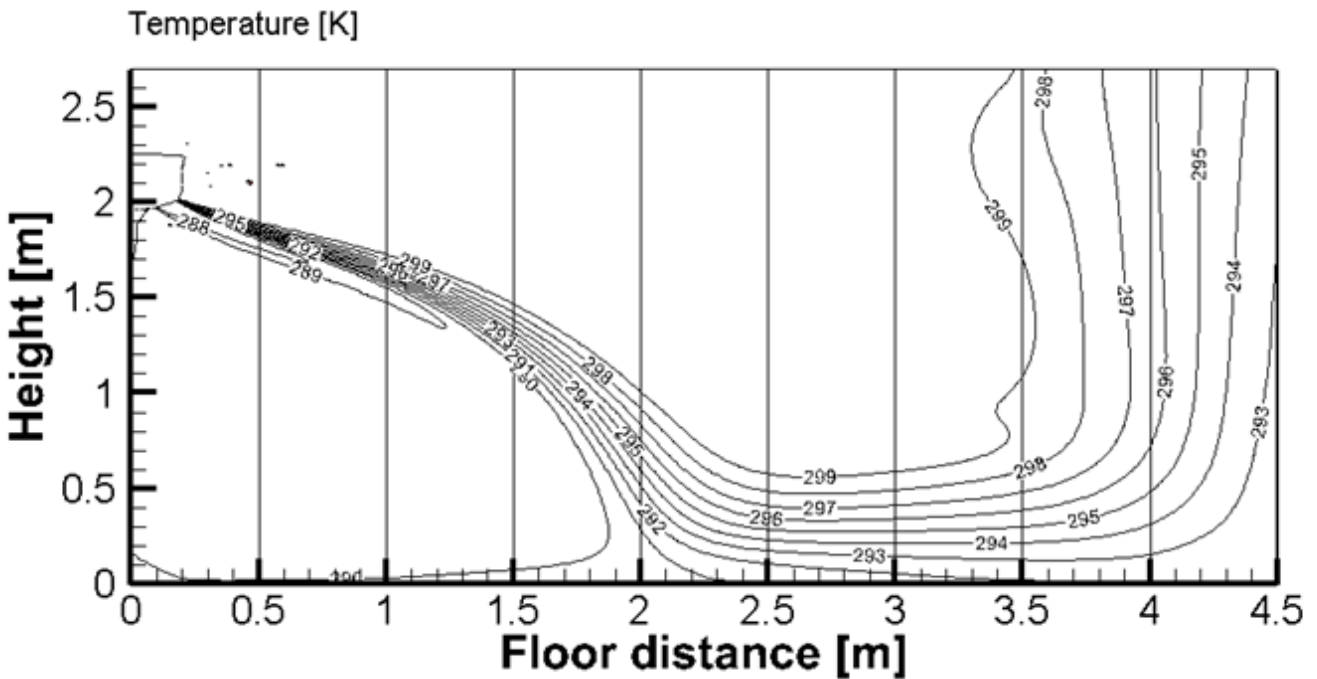

AURORA-9k

Heating(ID: 20°C/68°F, OD: 7°C/44.6°F)

Discharge Angle 90°

Airflow velocity distributions

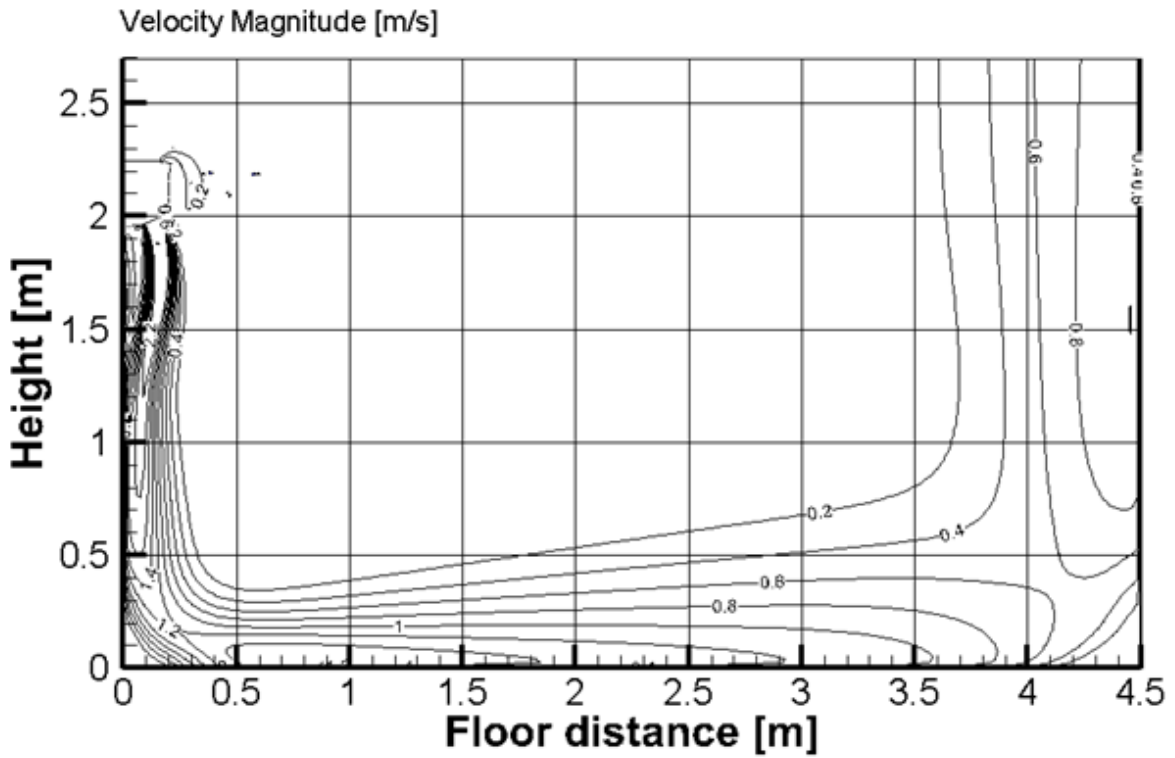

Temperature distributions

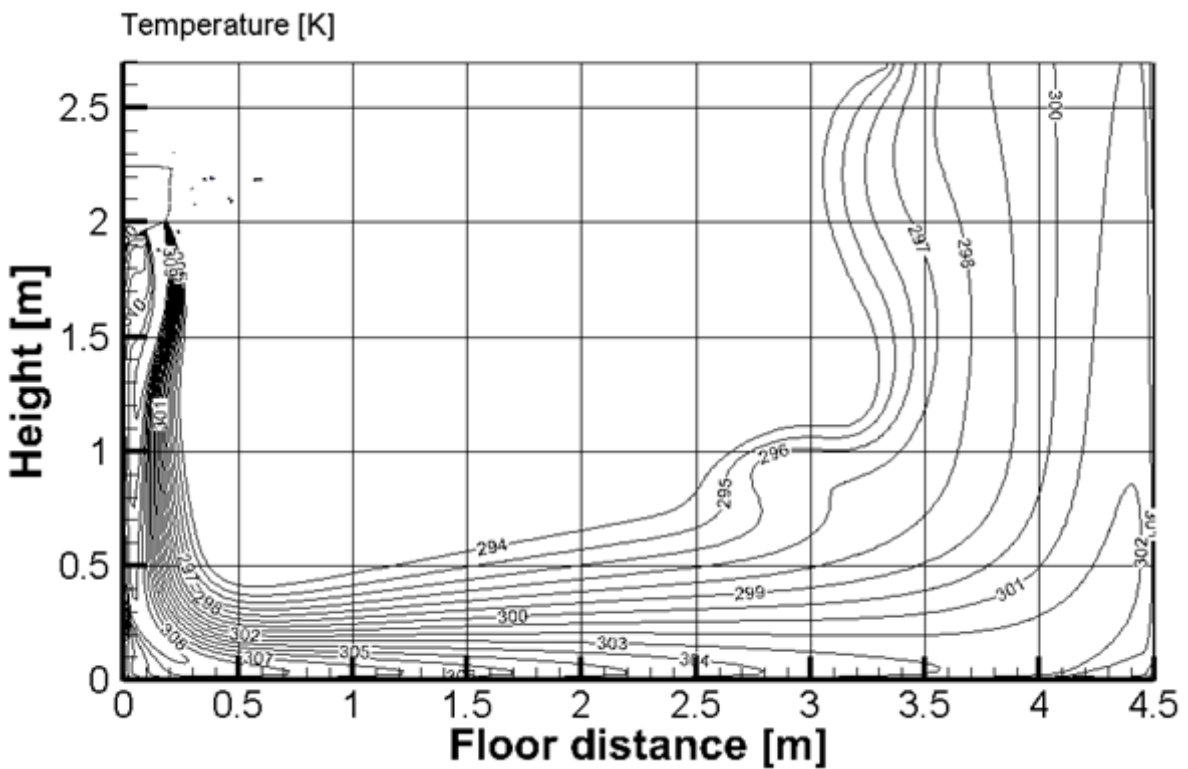

AURORA-12k

Cooling(ID: 27°C/80.6°F, OD: 35°C/95°F)

Discharge Angle 58°

Airflow velocity distributions

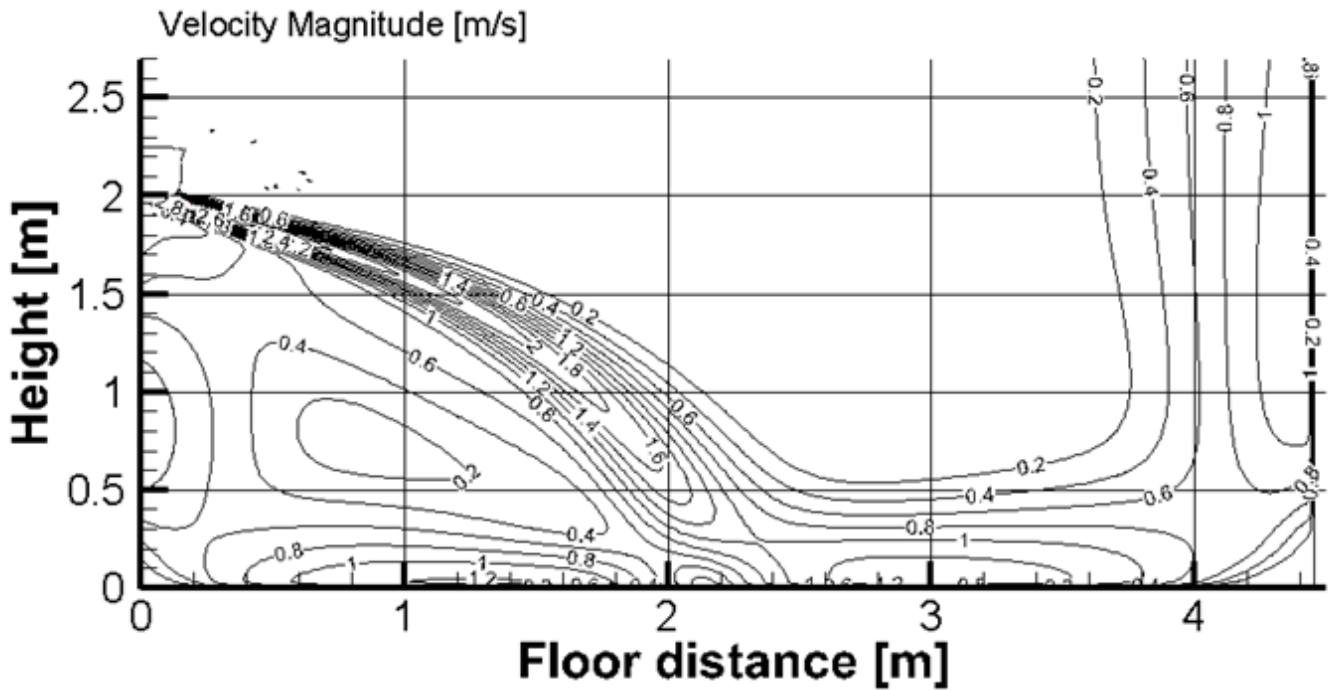

Temperature distributions

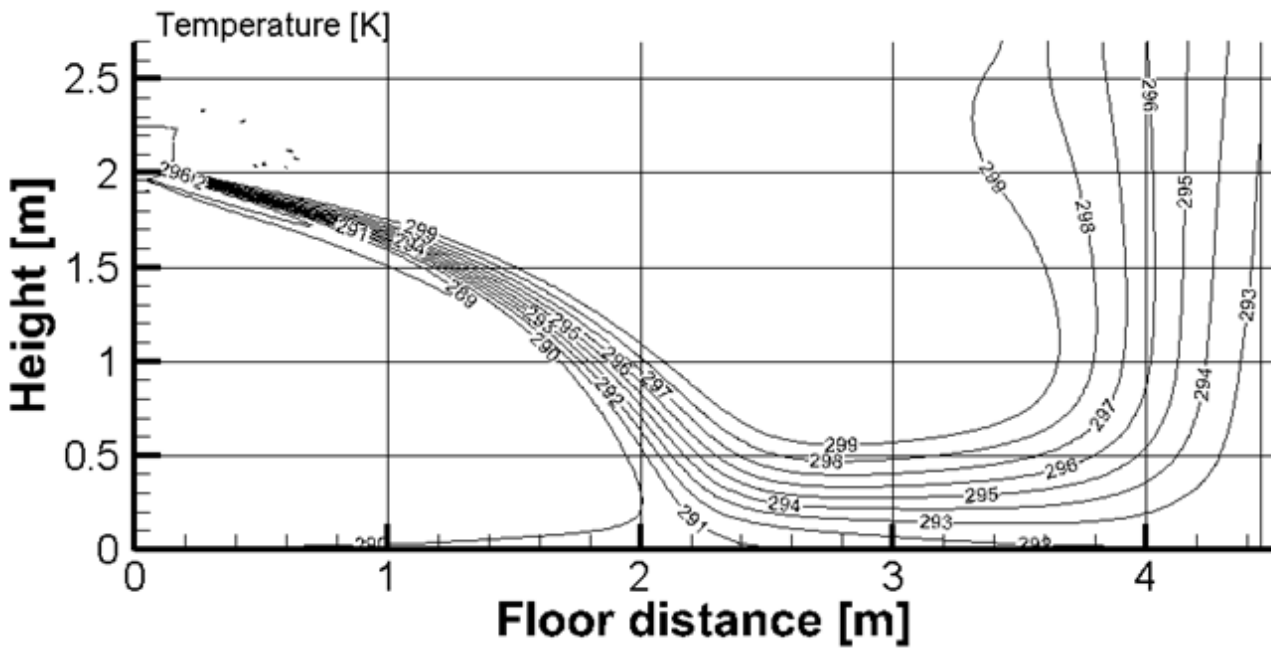

AURORA-12k

Heating(ID: 20°C/68°F, OD: 7°C/44.6°F)

Discharge Angle 90°

Airflow velocity distributions

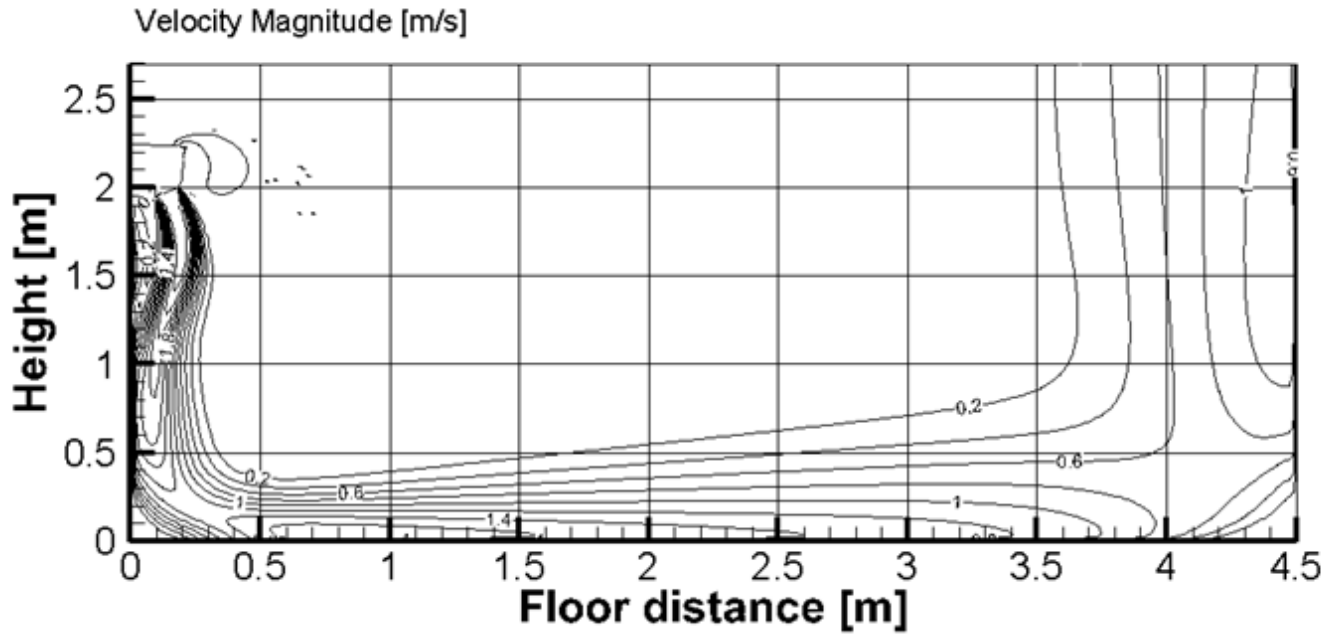

Temperature distributions

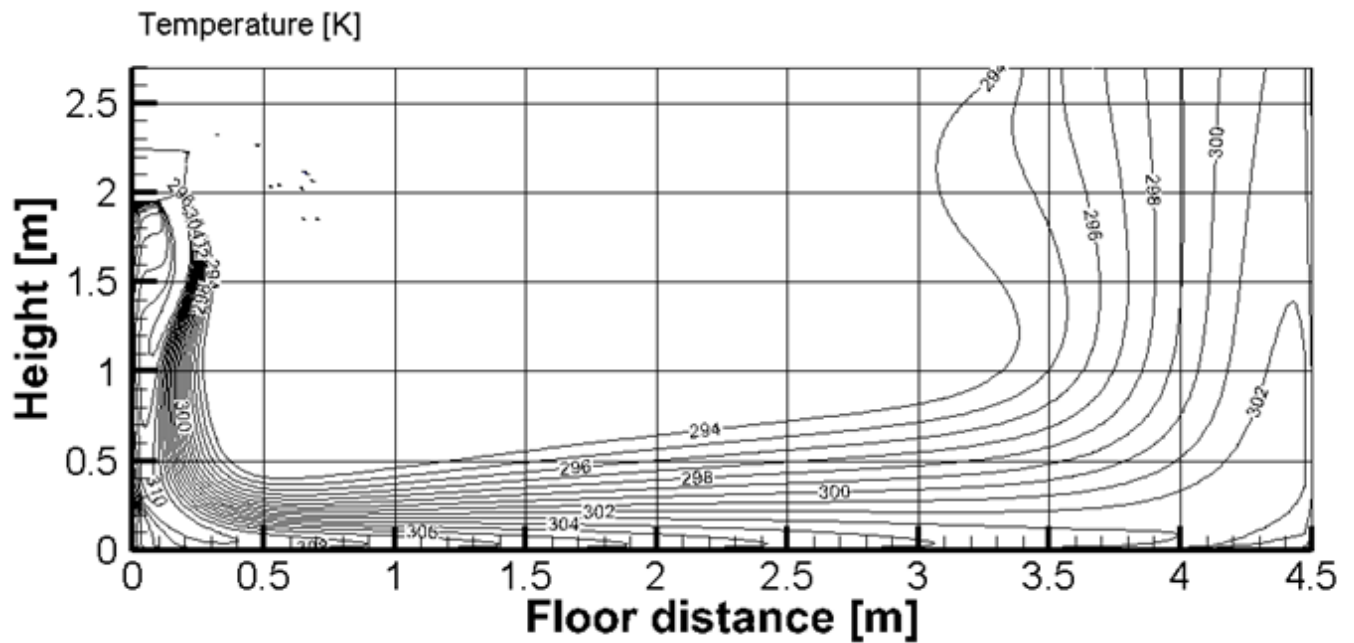

AURORA-18k

Cooling(ID: 27°C/80.6°F, OD: 35°C/95°F)

Discharge Angle 50°

Airflow velocity distributions

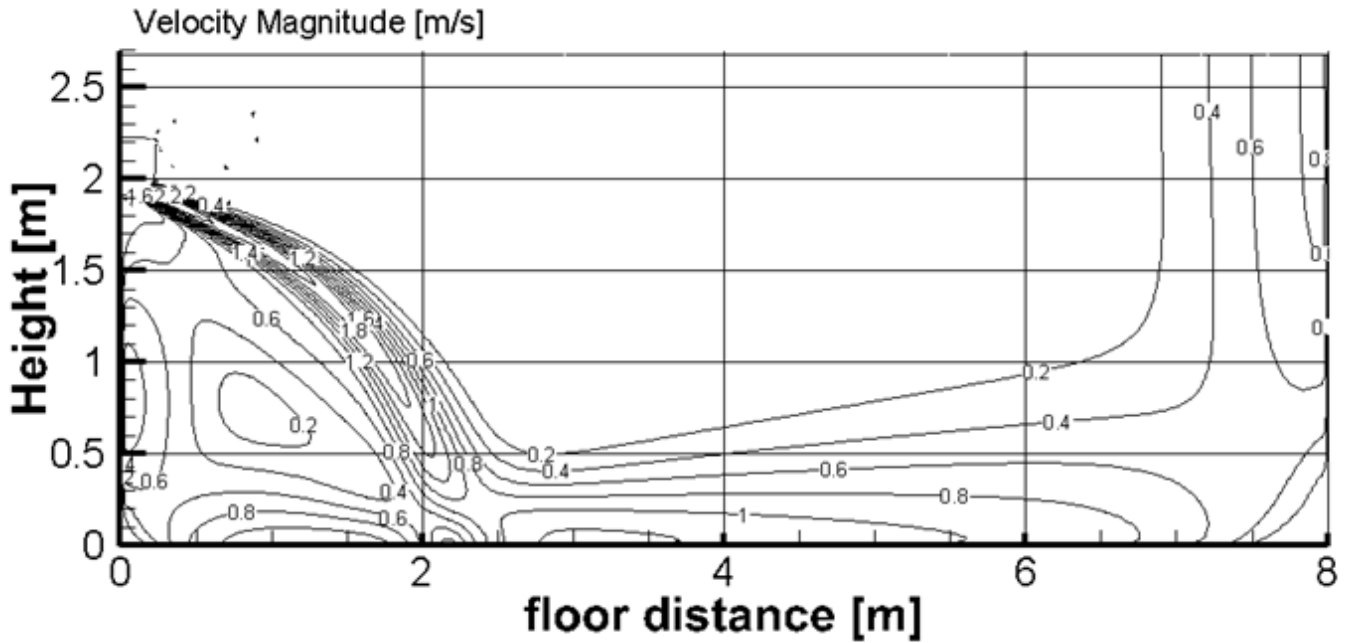

Temperature distributions

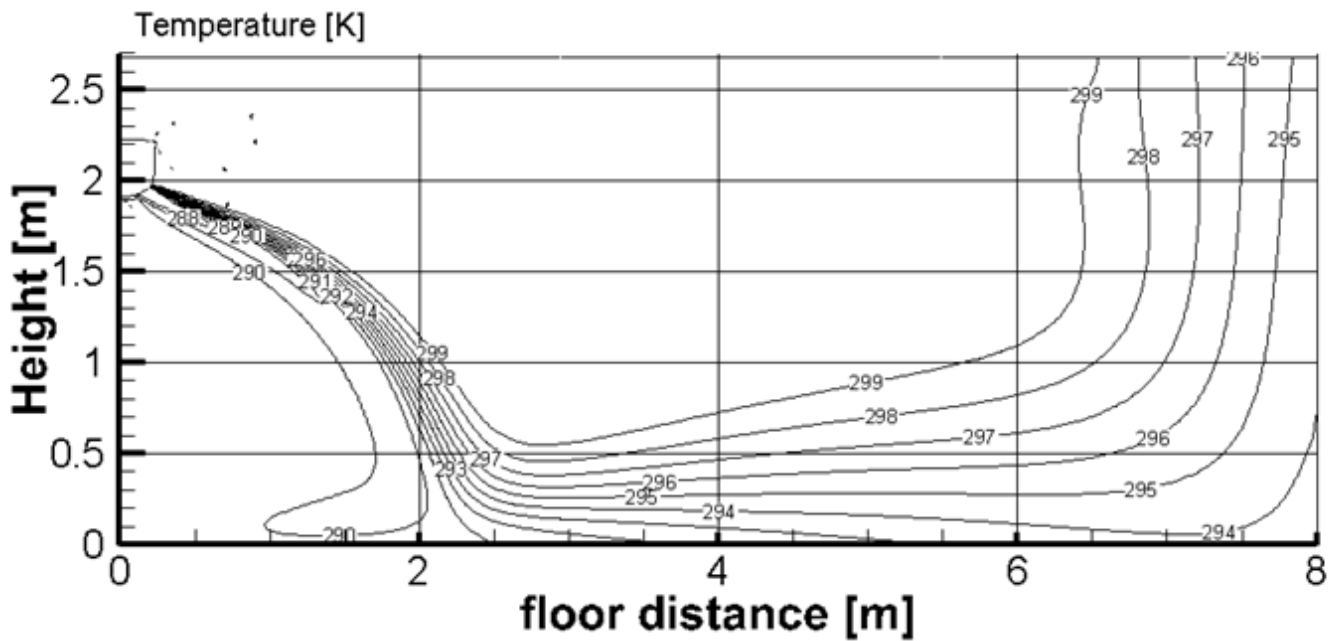

AURORA-18k

Heating(ID: 20°C/68°F, OD: 7°C/44.6°F)

Discharge Angle 84°

Airflow velocity distributions

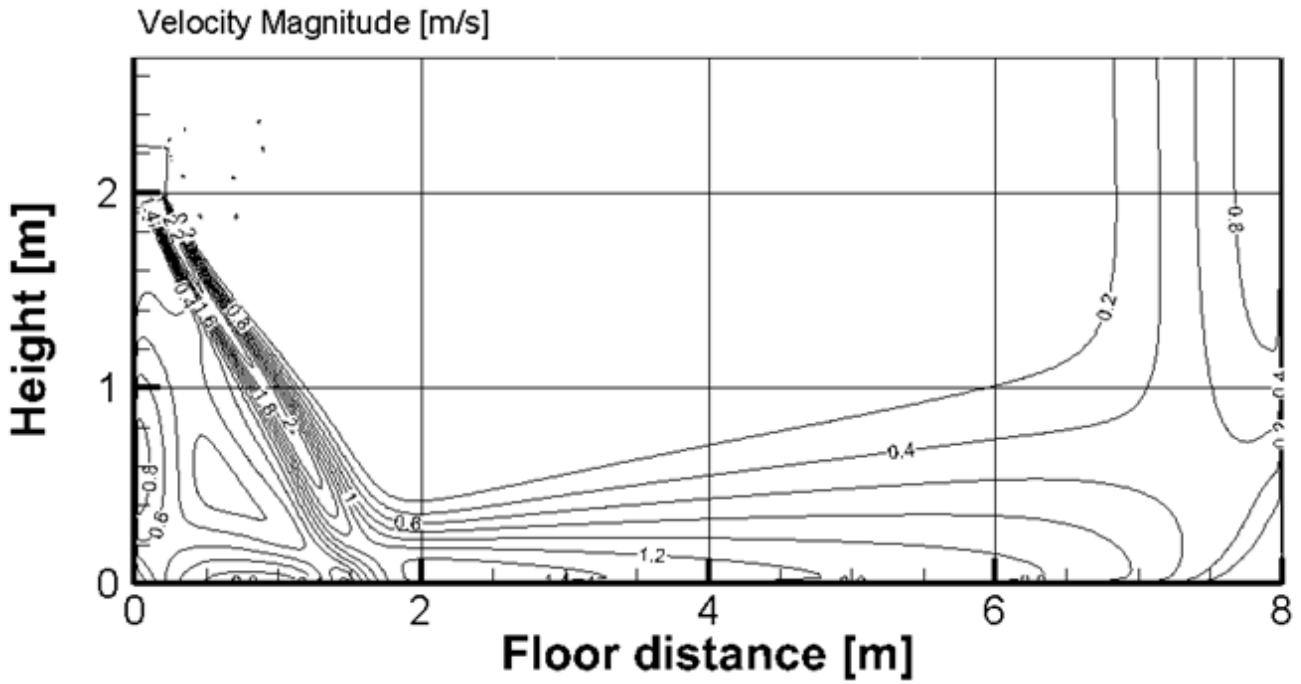

Temperature distributions

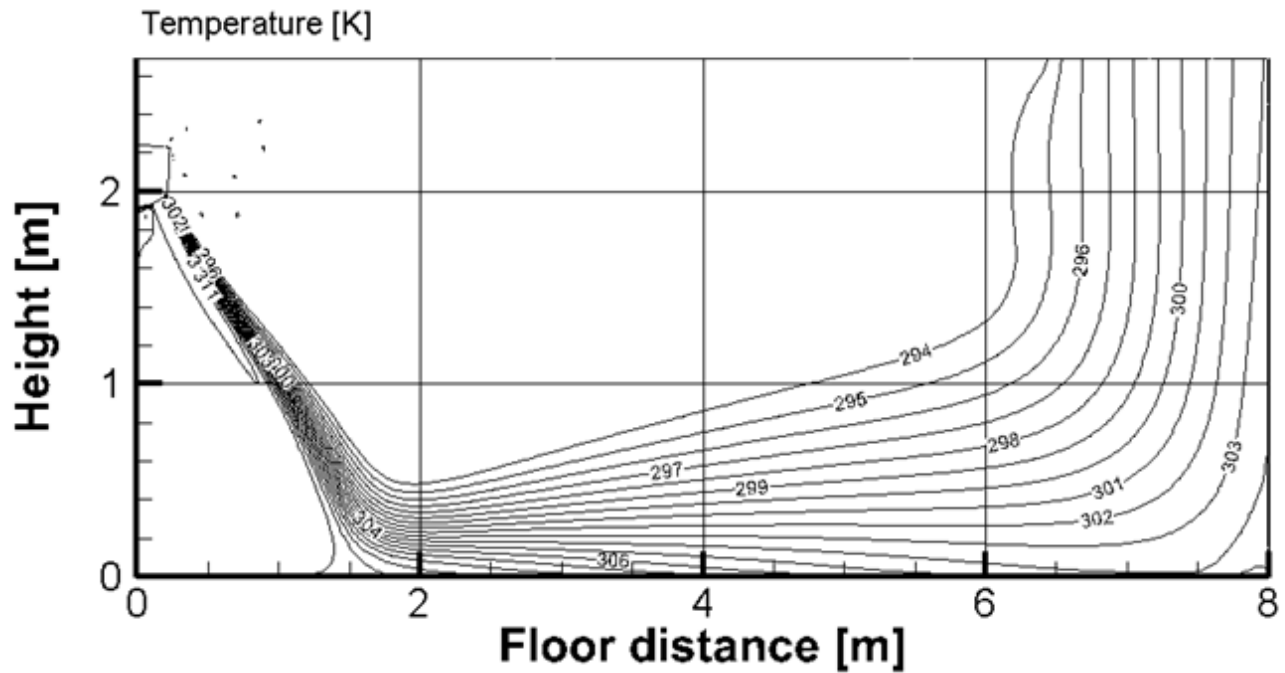

AURORA-24k

Cooling(ID: 27°C/80.6°F, OD: 35°C/95°F)

Discharge Angle 50°

Airflow velocity distributions

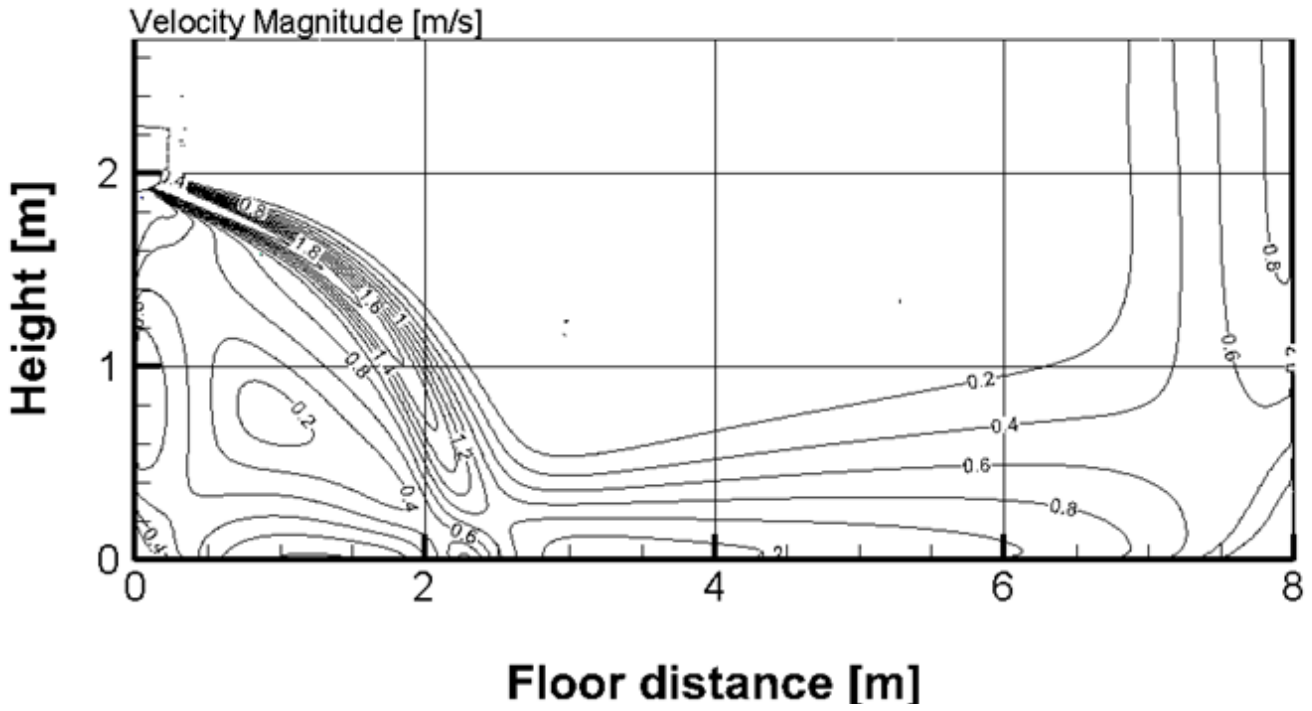

Cooling temperature distributions

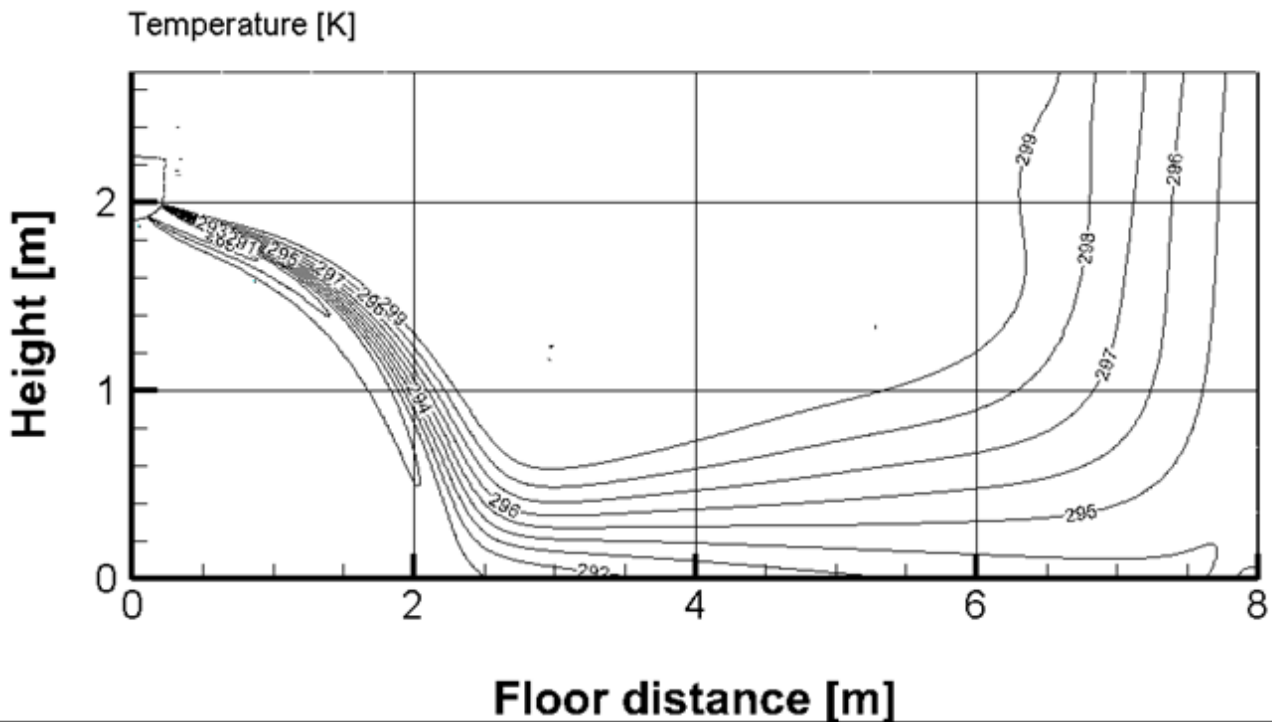

AURORA-24k

Heating(ID: 20°C/68°F, OD: 7°C/44.6°F)

Discharge Angle 67°

Airflow velocity distributions

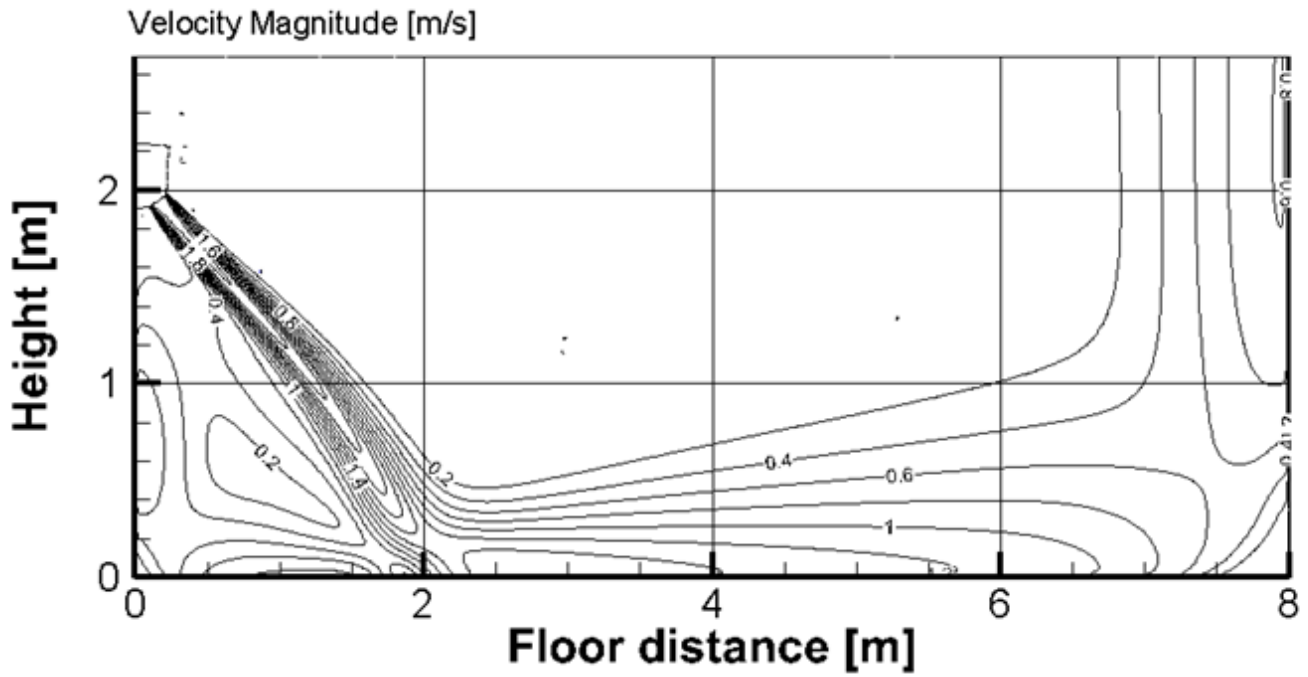

Temperature distributions

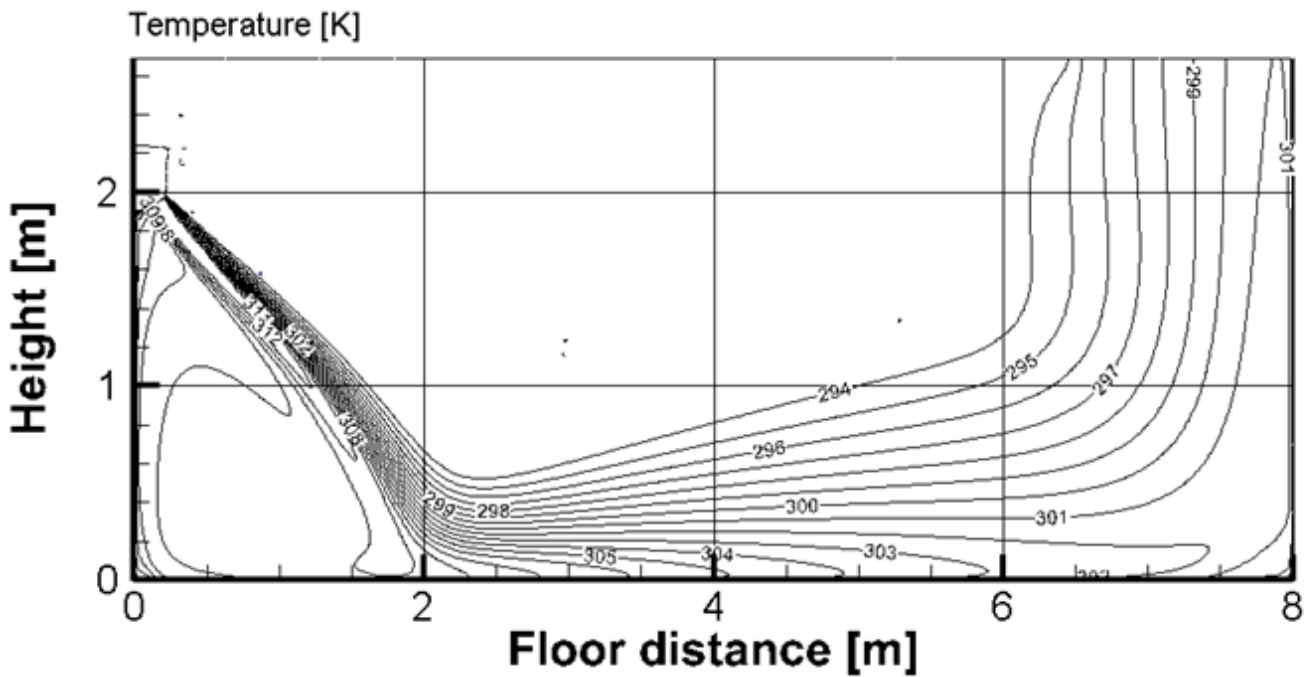

AURORA &Infini-30k

Cooling(ID: 27°C/80.6°F, OD: 35°C/95°F)

Discharge Angle 55°

Airflow velocity distributions

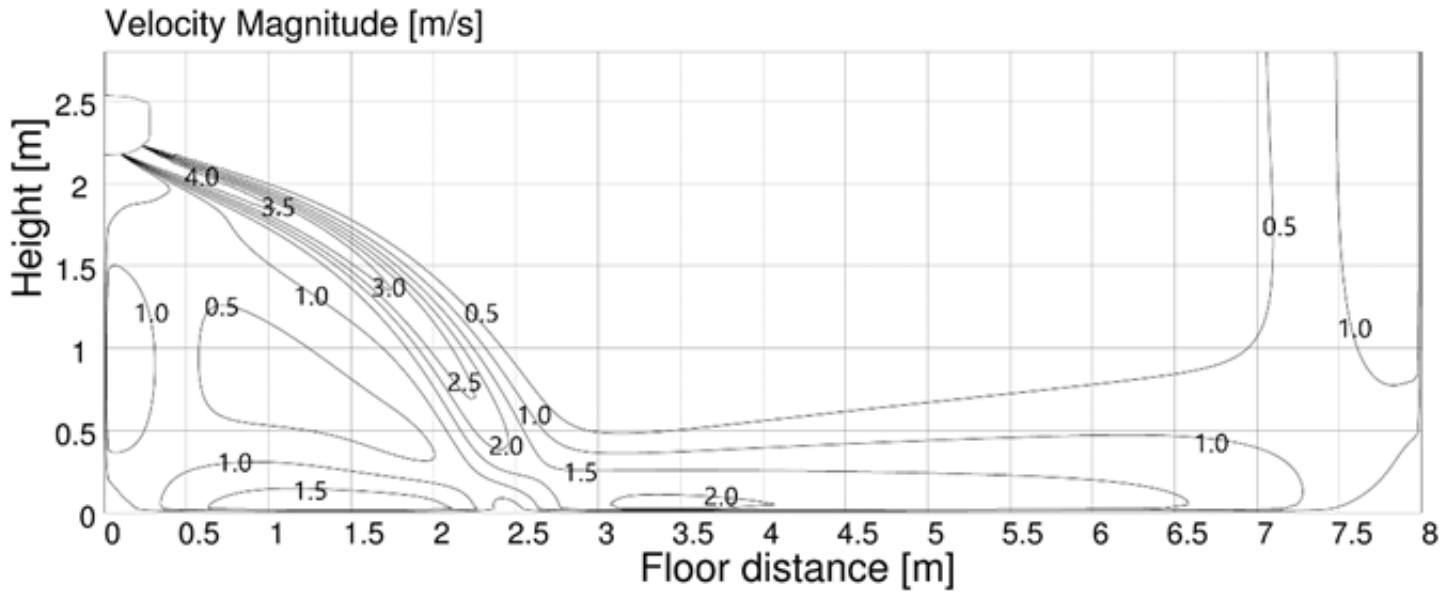

Temperature distributions

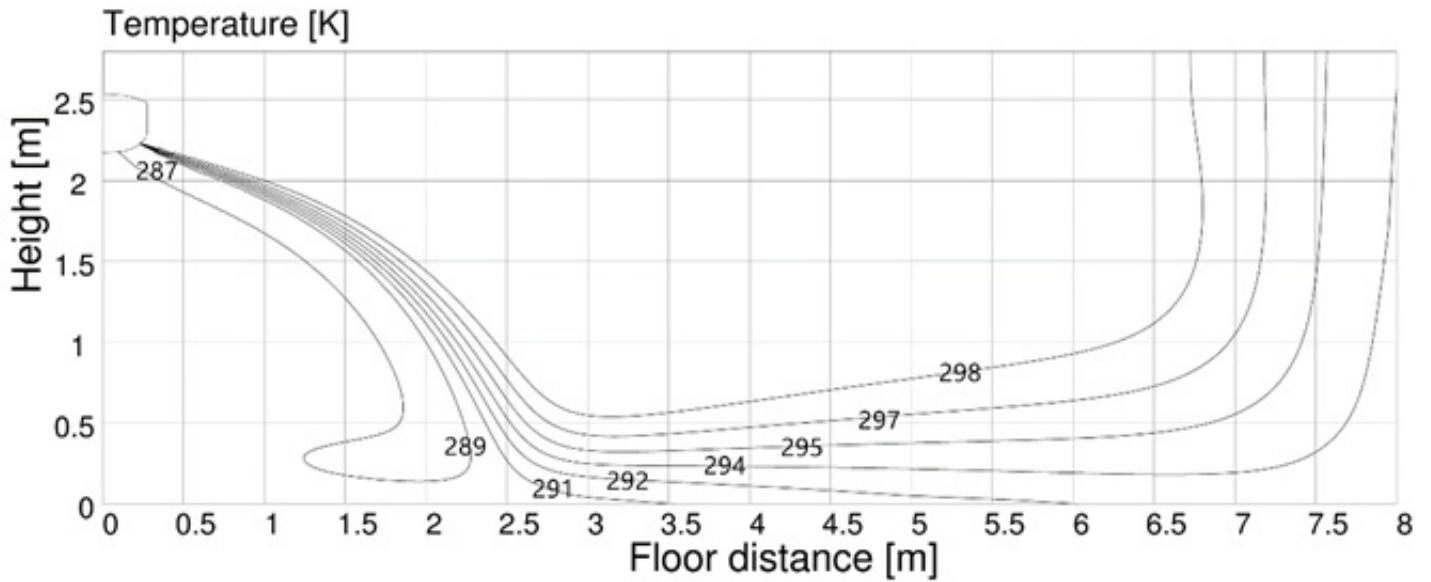

AURORA & Infini-30k

Heating (ID: 20°C/68°F, OD: 7°C/44.6°F)

Discharge Angle 75°

Airflow velocity distributions

Velocity Magnitude [m/s]

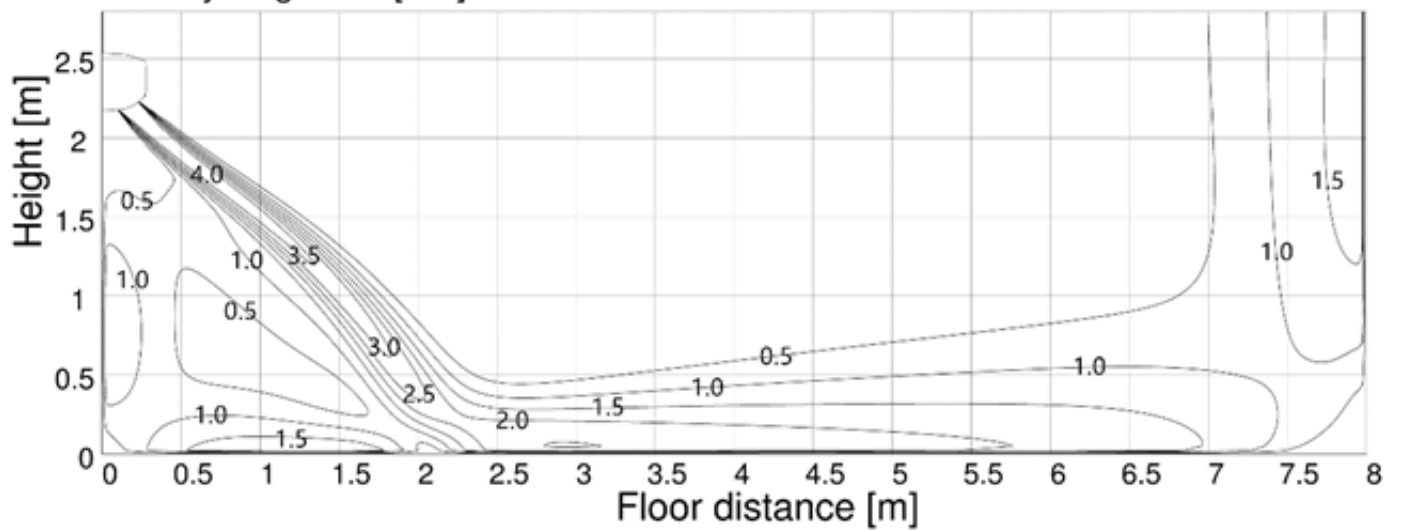

Temperature distributions

Temperature [K]

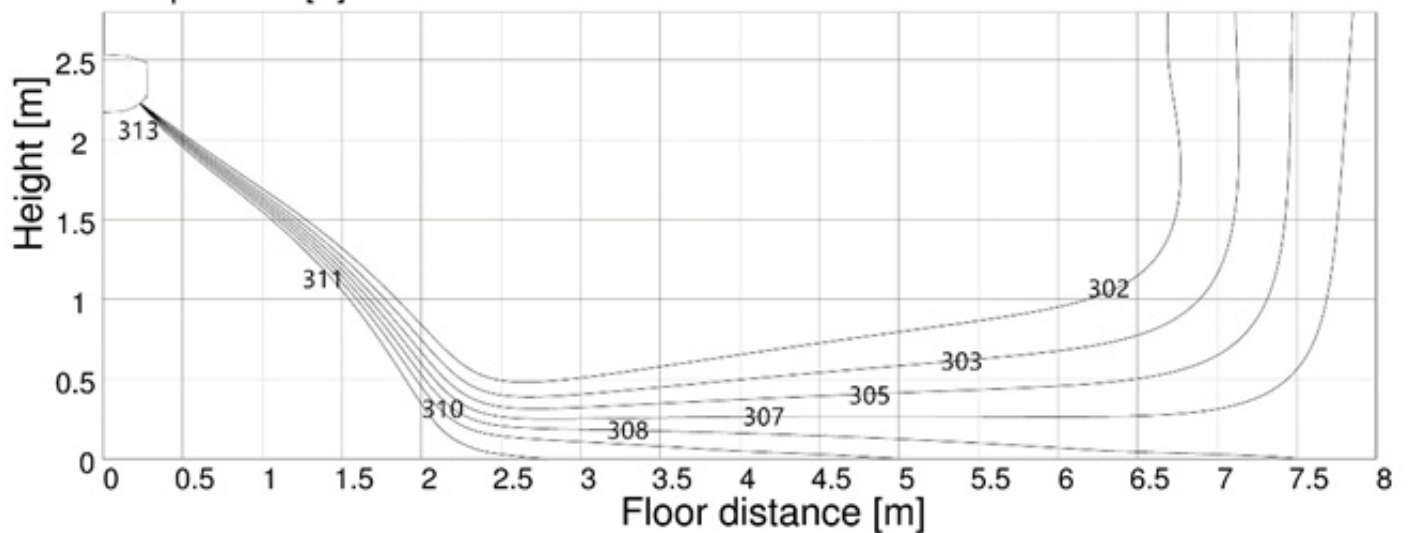

AURORA & Infini-36k

Cooling(ID: 27°C/80.6°F, OD: 35°C/95°F)

Discharge Angle 55°

Airflow velocity distributions

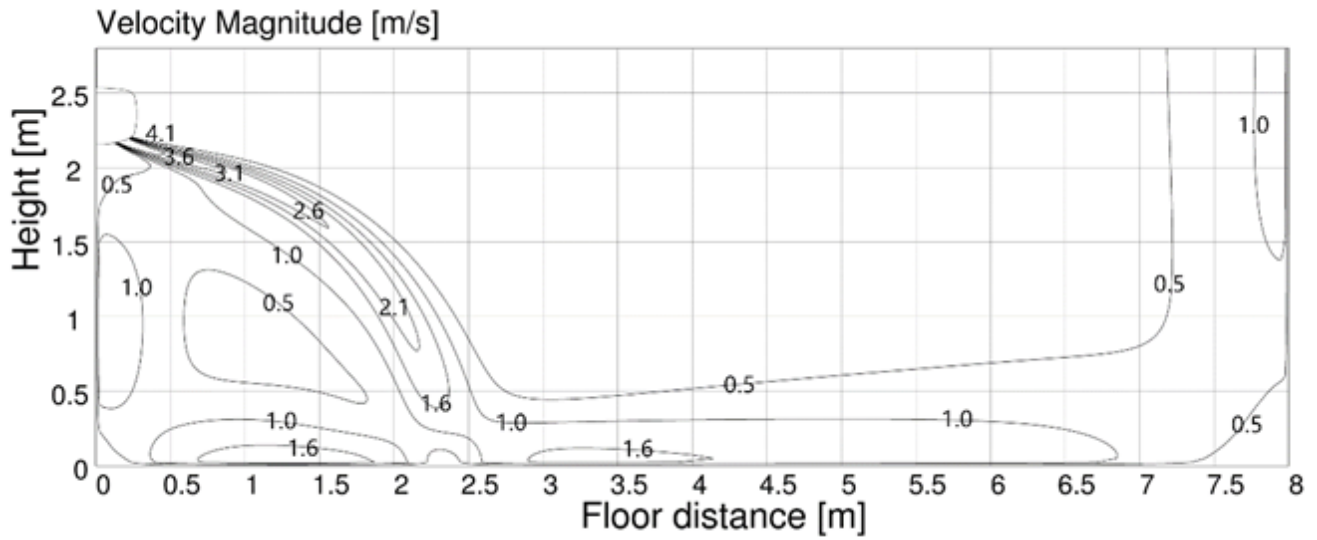

Temperature distributions

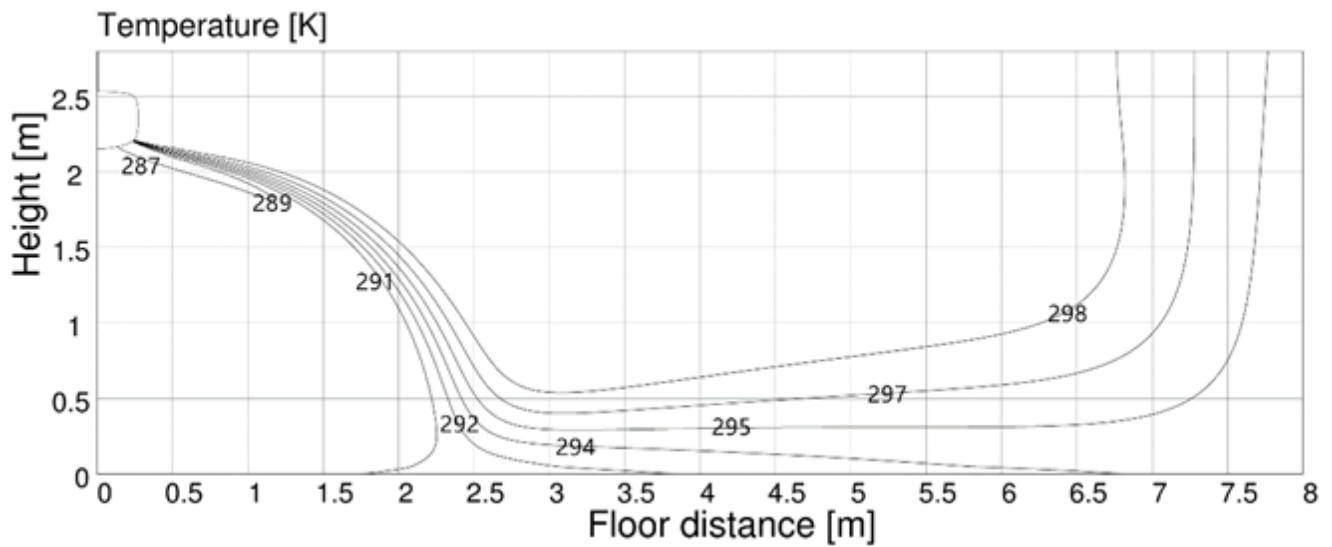

AURORA & Infini-36k

Heating(ID: 20°C/68°F, OD: 7°C/44.6°F)

Discharge Angle 75°

Airflow velocity distributions

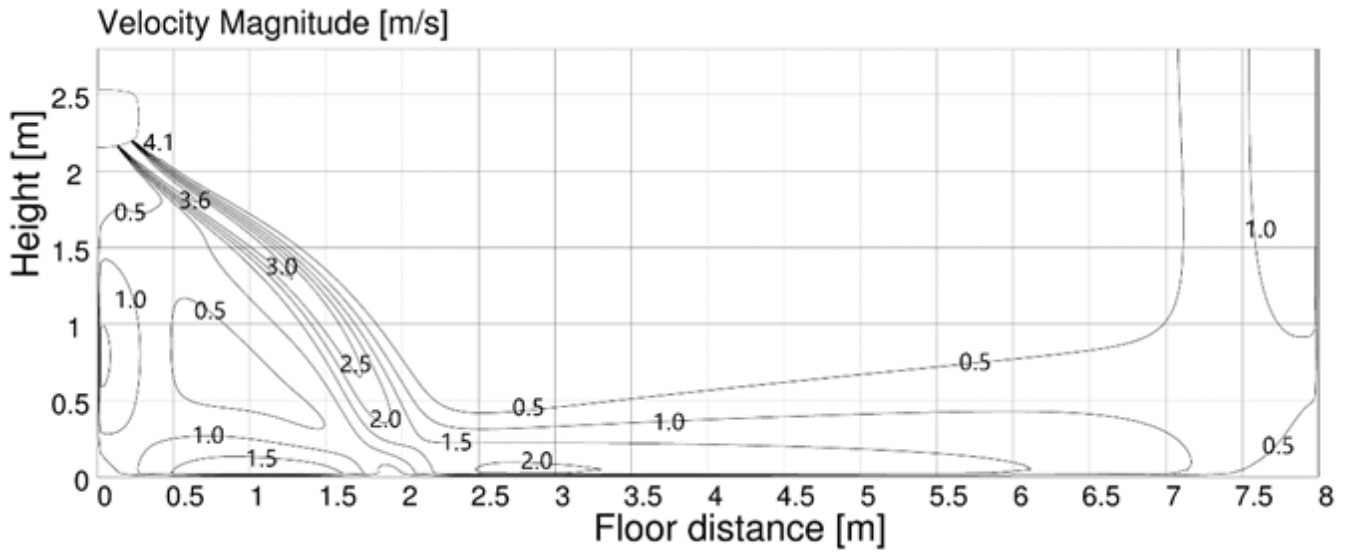

Temperature distributions

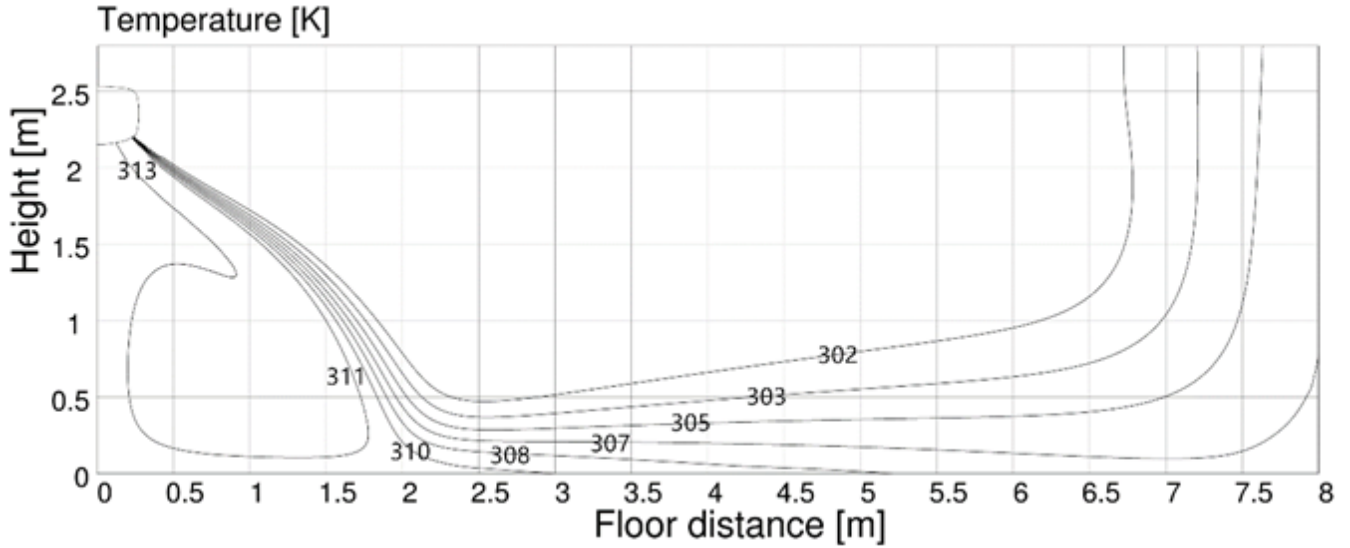

All Easy Pro-6k&9k

Cooling(ID: 27°C/80.6°F, OD: 35°C/95°F)

Discharge Angle 60°

Airflow velocity distributions

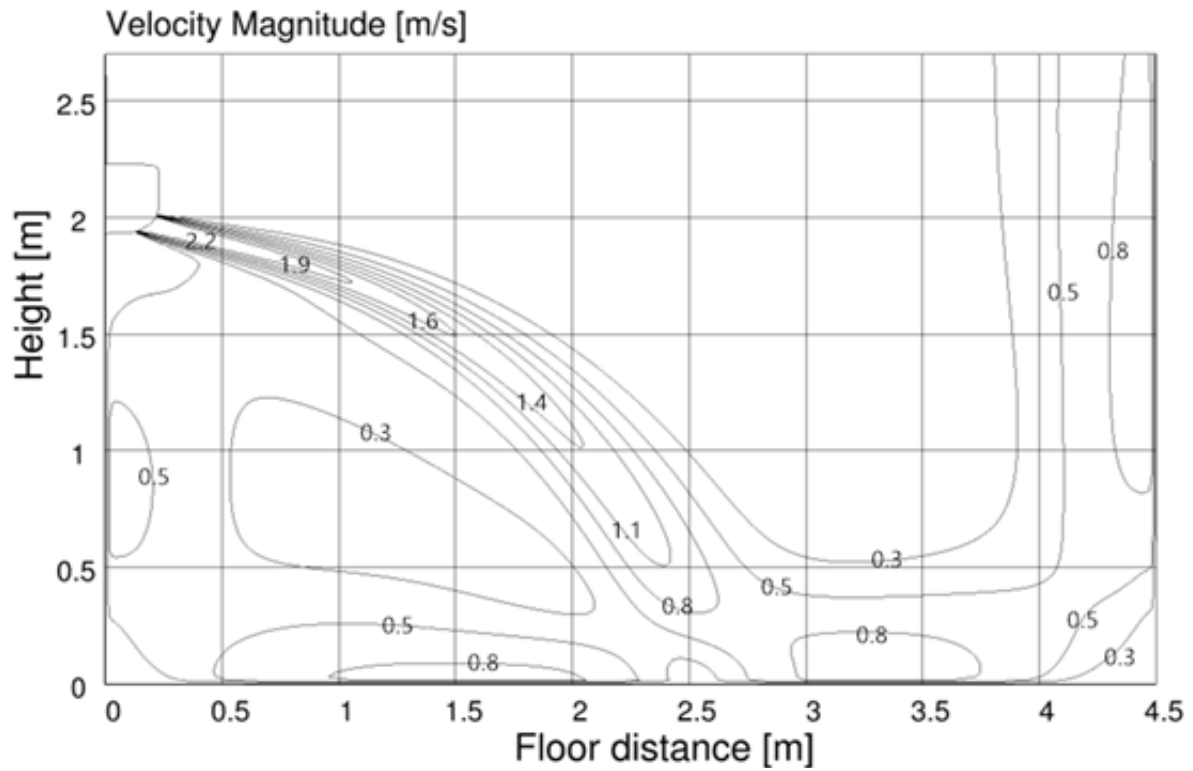

Temperature distributions

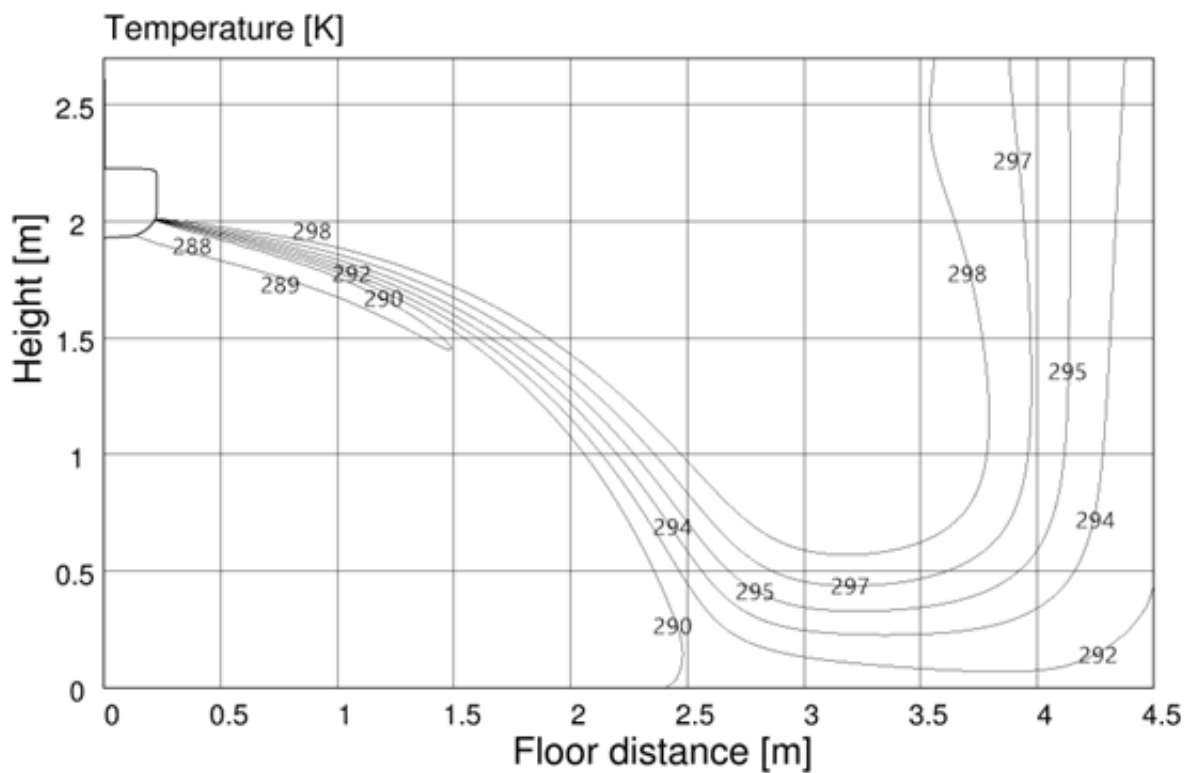

All Easy Pro-6k&9k

Heating(ID: 20°C/68°F, OD: 7°C/44.6°F)

Discharge Angle 110°

Airflow velocity distributions

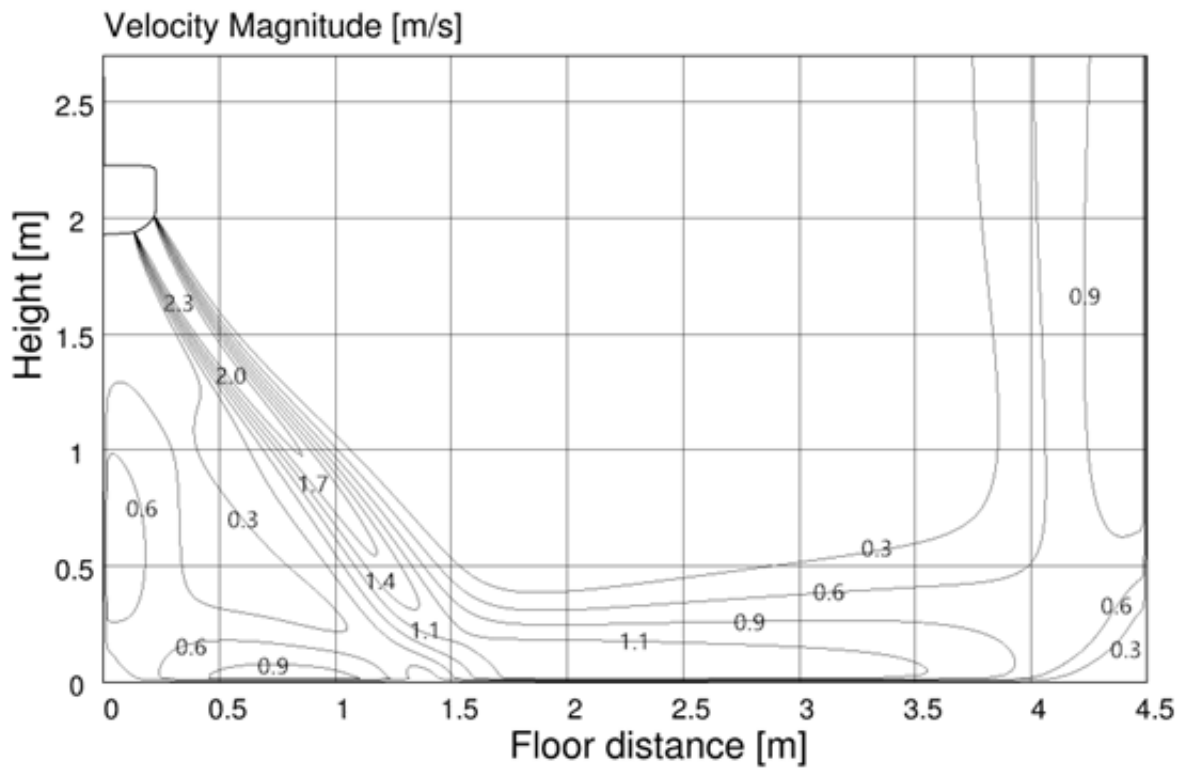

Temperature distributions

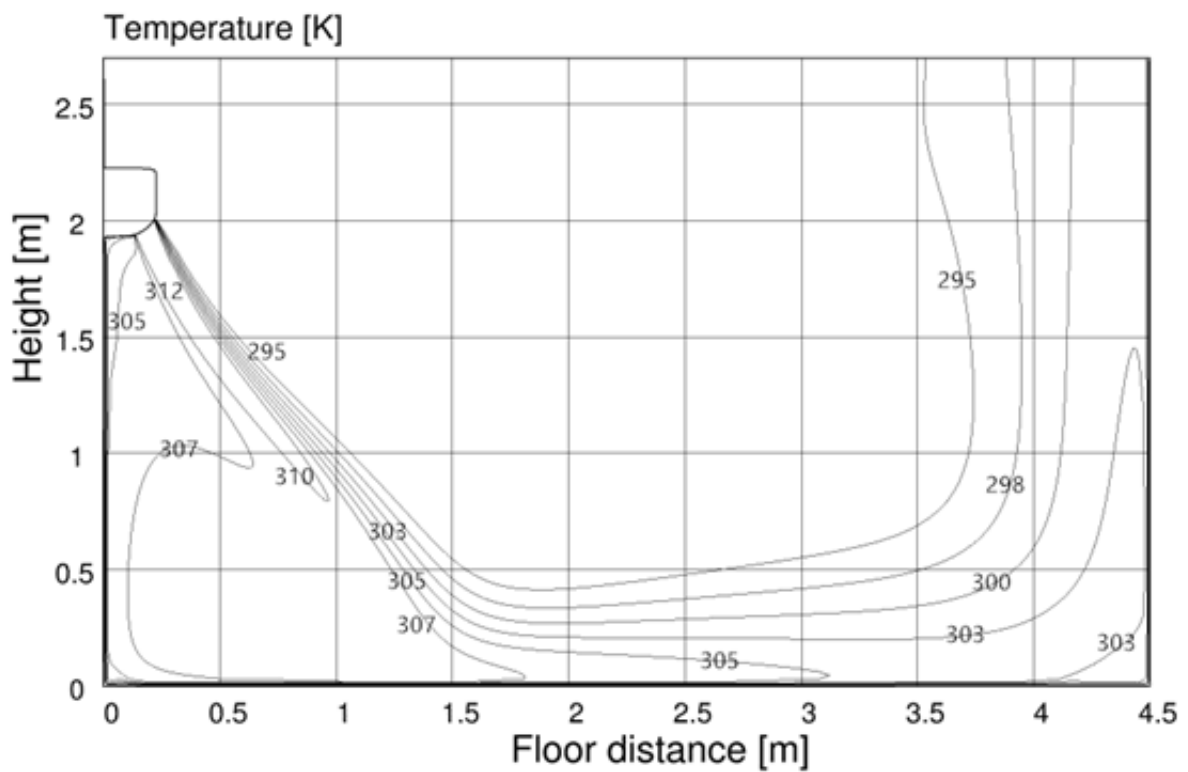

All Easy Pro-12k

Cooling(ID: 27°C/80.6°F, OD: 35°C/95°F)

Discharge Angle 60°

Airflow velocity distributions

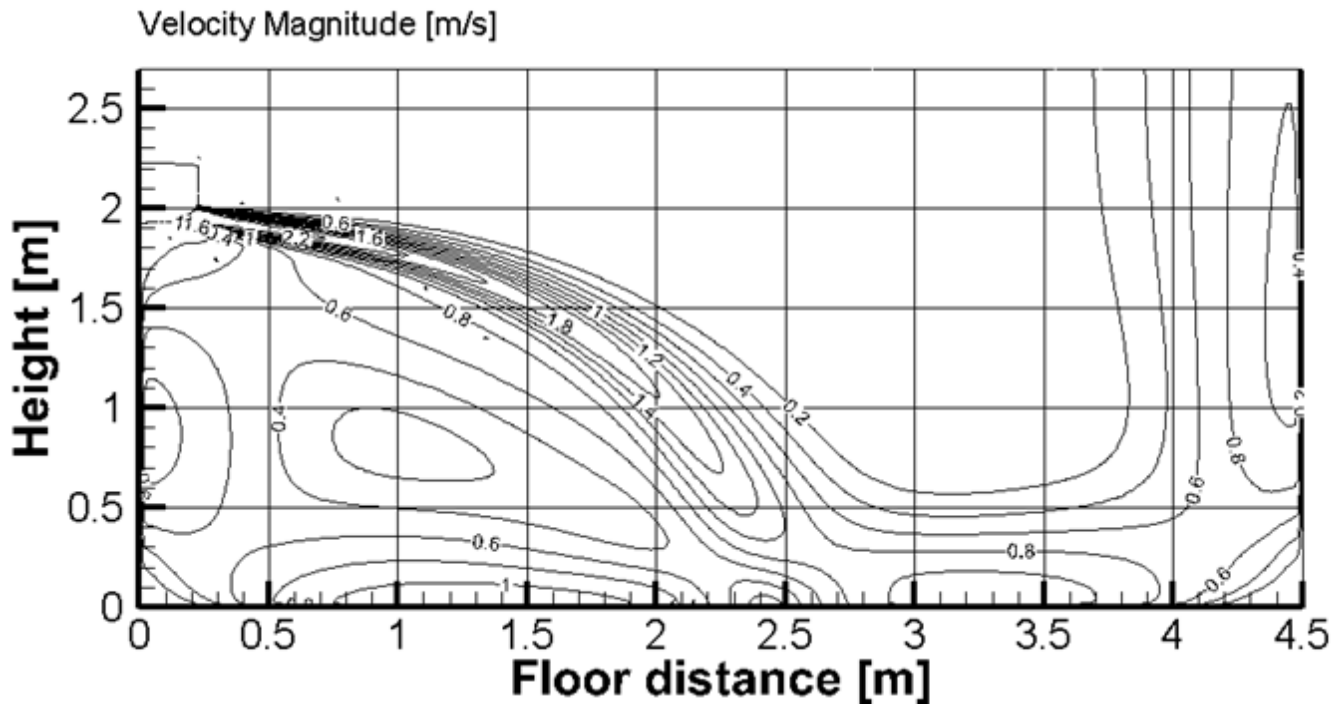

Temperature distributions

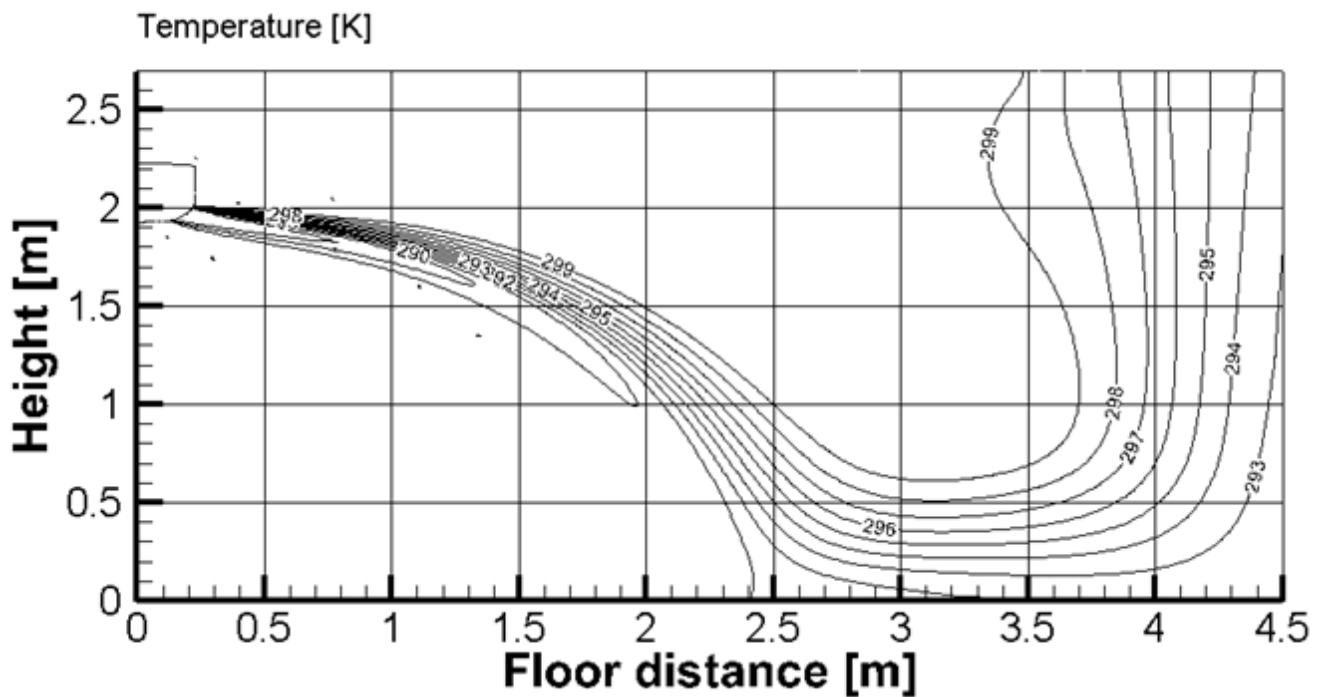

All Easy Pro-12k

Heating(ID: 20°C/68°F, OD: 7°C/44.6°F)

Discharge Angle 110°

Airflow velocity distributions

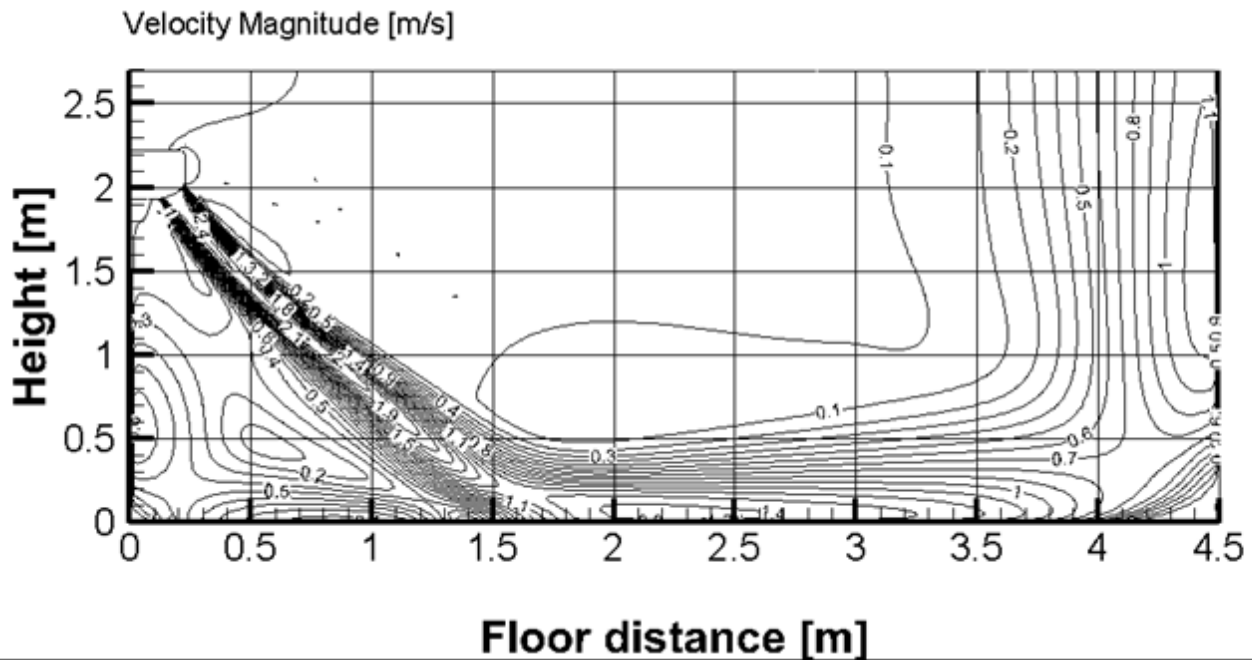

Temperature distributions

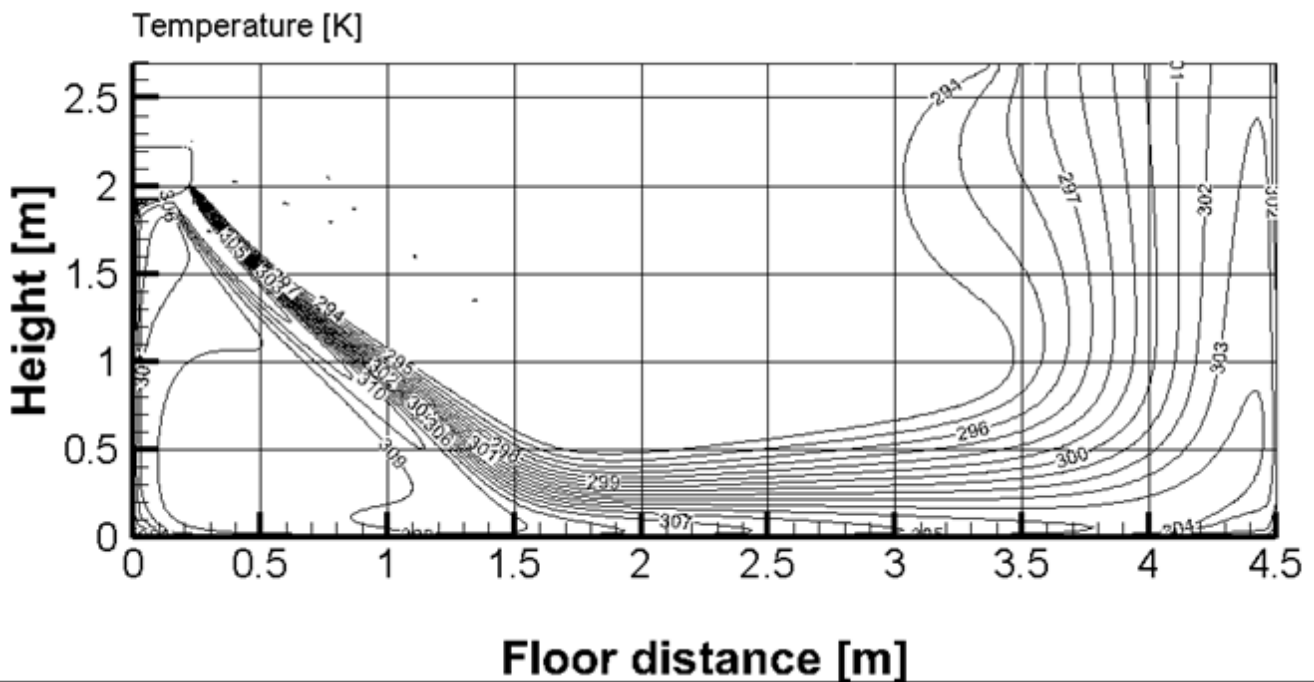

All Easy Pro-18k

Cooling(ID: 27°C/80.6°F, OD: 35°C/95°F)

Discharge Angle 60°

Airflow velocity distributions

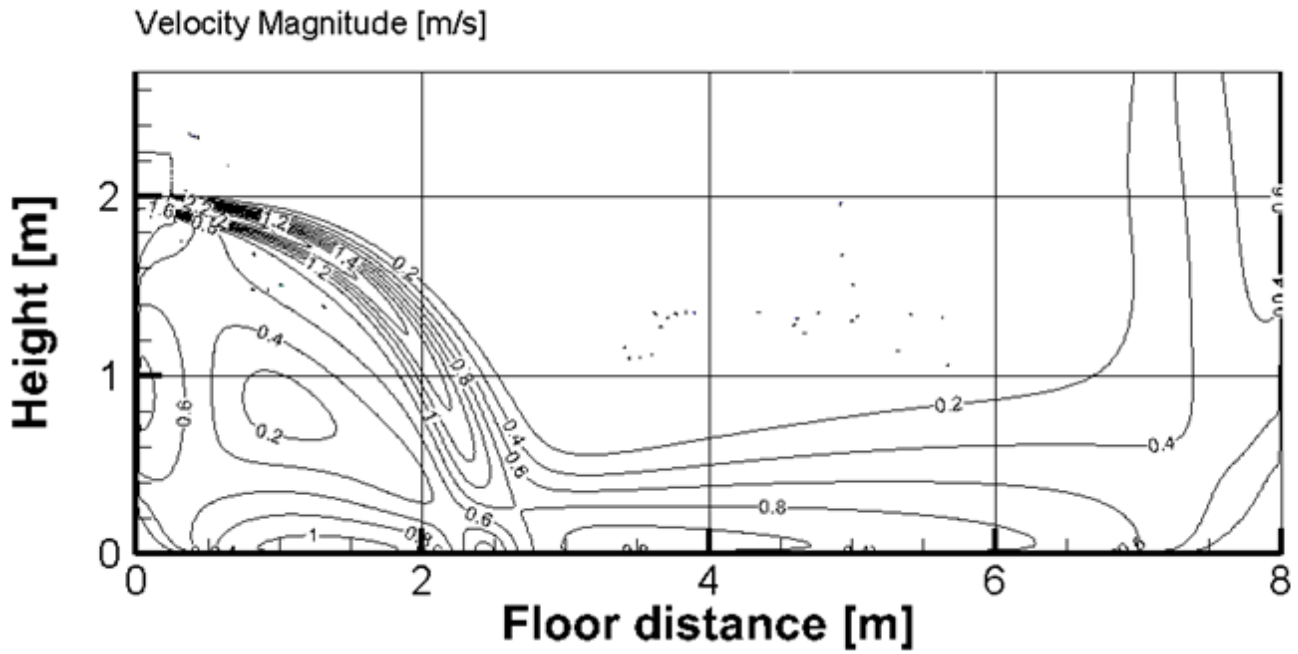

Temperature distributions

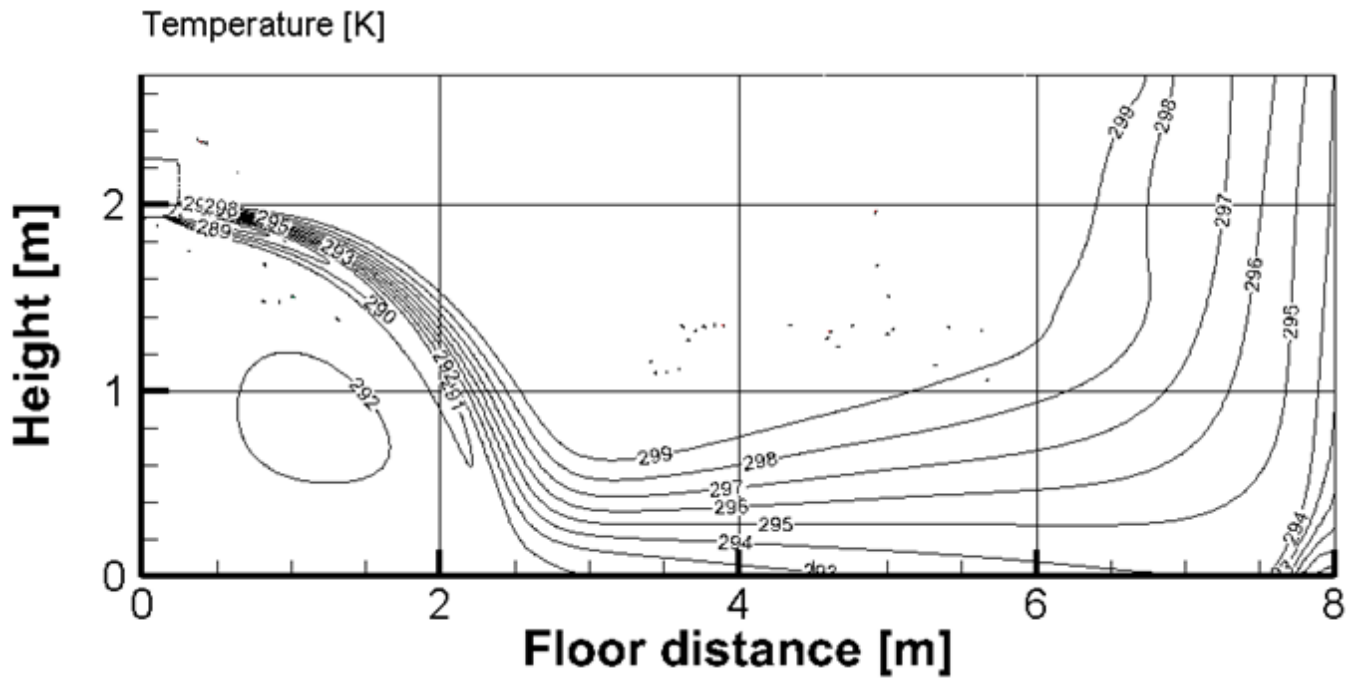

All Easy Pro-18k

Heating(ID: 20°C/68°F, OD: 7°C/44.6°F)

Discharge Angle 95°

Airflow velocity distributions

Velocity Magnitude [m/s]

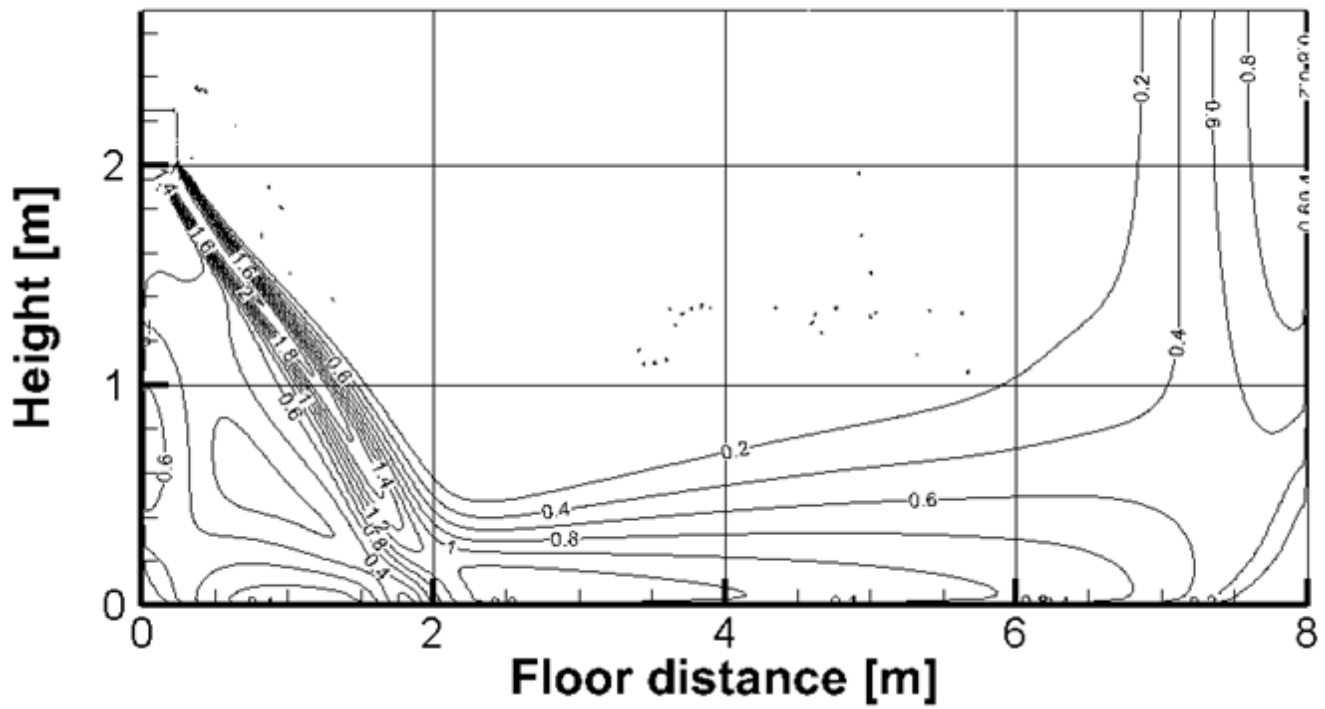

Temperature distributions

Temperature [K]

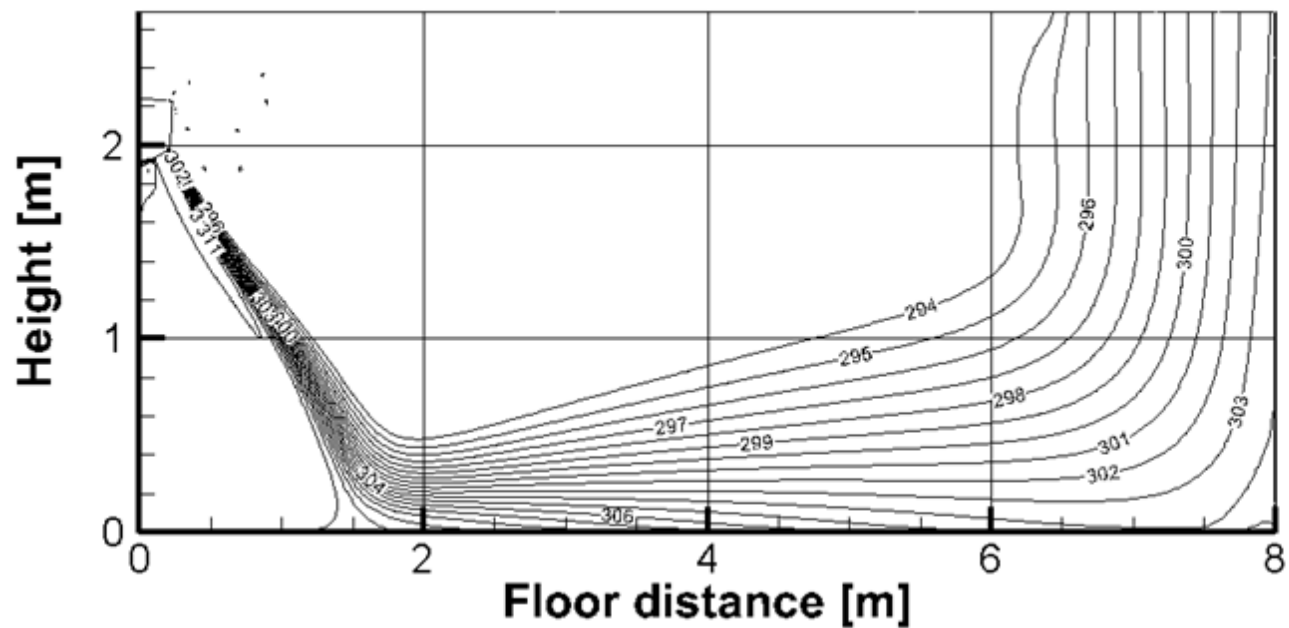

All Easy Pro-24k

Cooling(ID: 27°C/80.6°F, OD: 35°C/95°F)

Discharge Angle 65°

Airflow velocity distributions

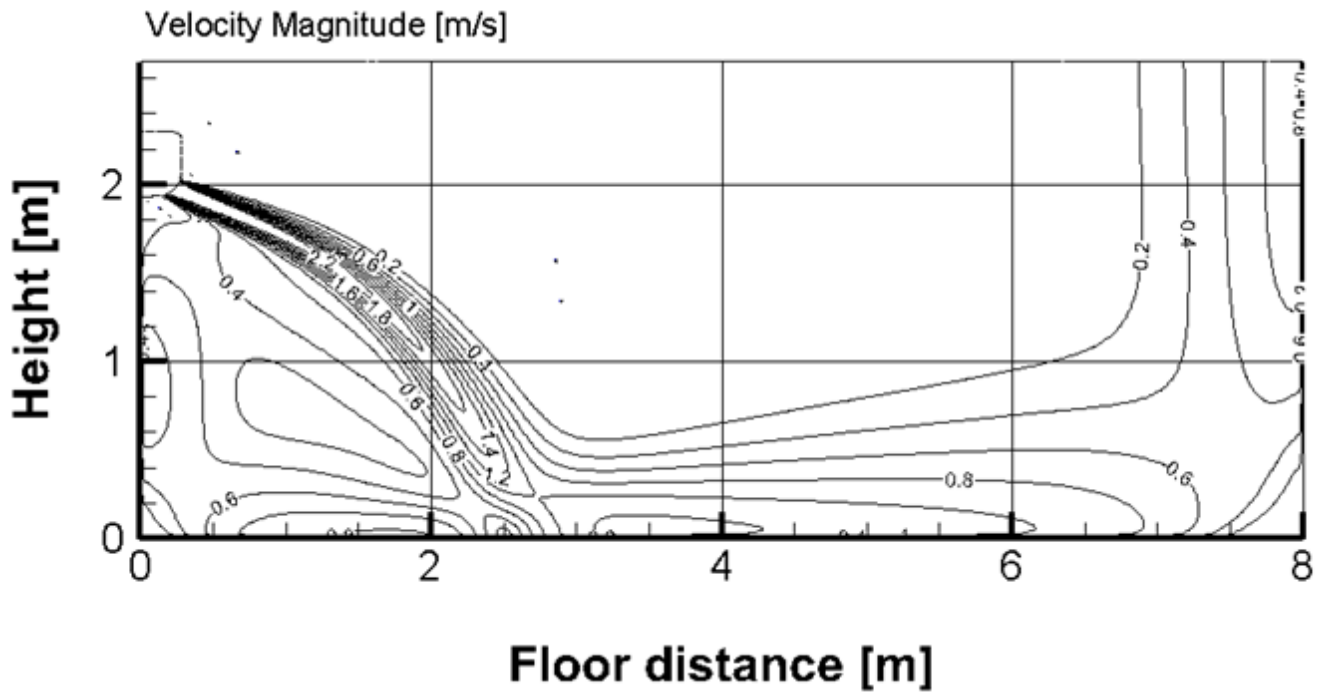

Temperature distributions

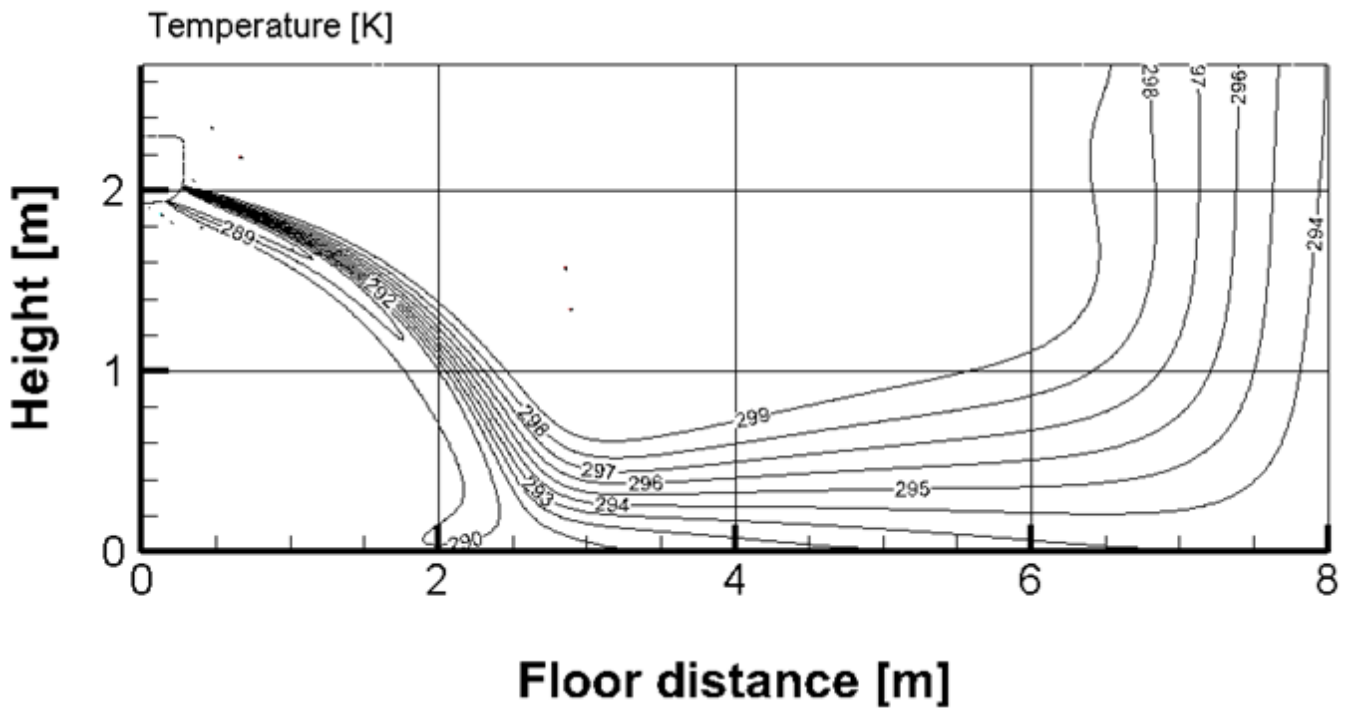

All Easy Pro-24k

Heating(ID: 20°C/68°F, OD: 7°C/44.6°F)

Discharge Angle 100°

Airflow velocity distributions

Velocity Magnitude [m/s]

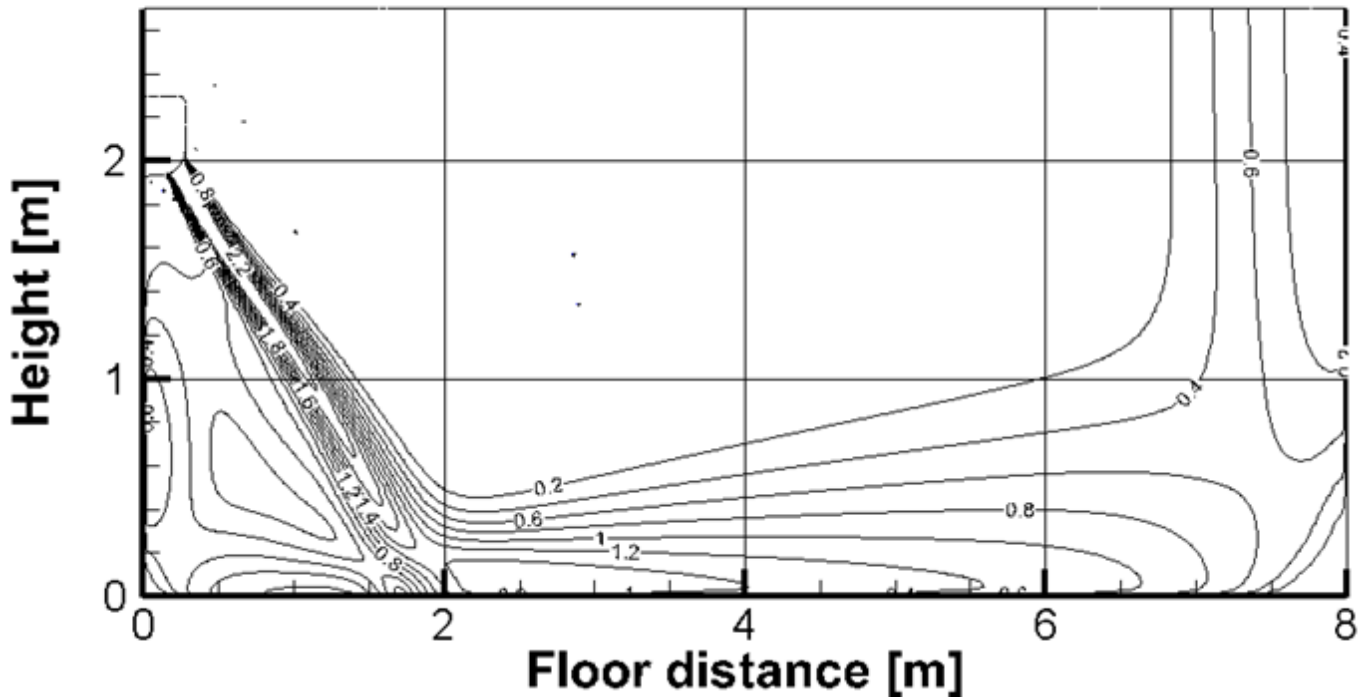

Temperature distributions

Temperature [K]

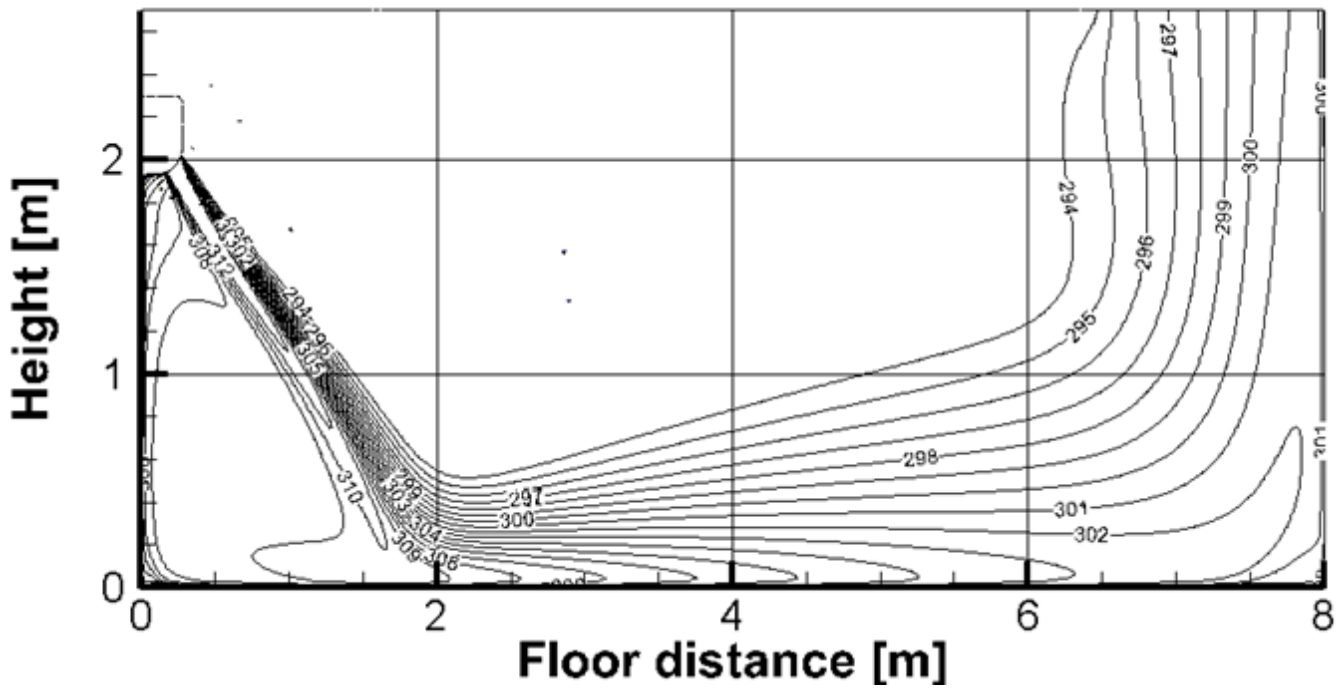

All Easy Pro-30k

Cooling(ID: 27°C/80.6°F, OD: 35°C/95°F)

Discharge Angle 65°

Airflow velocity distributions

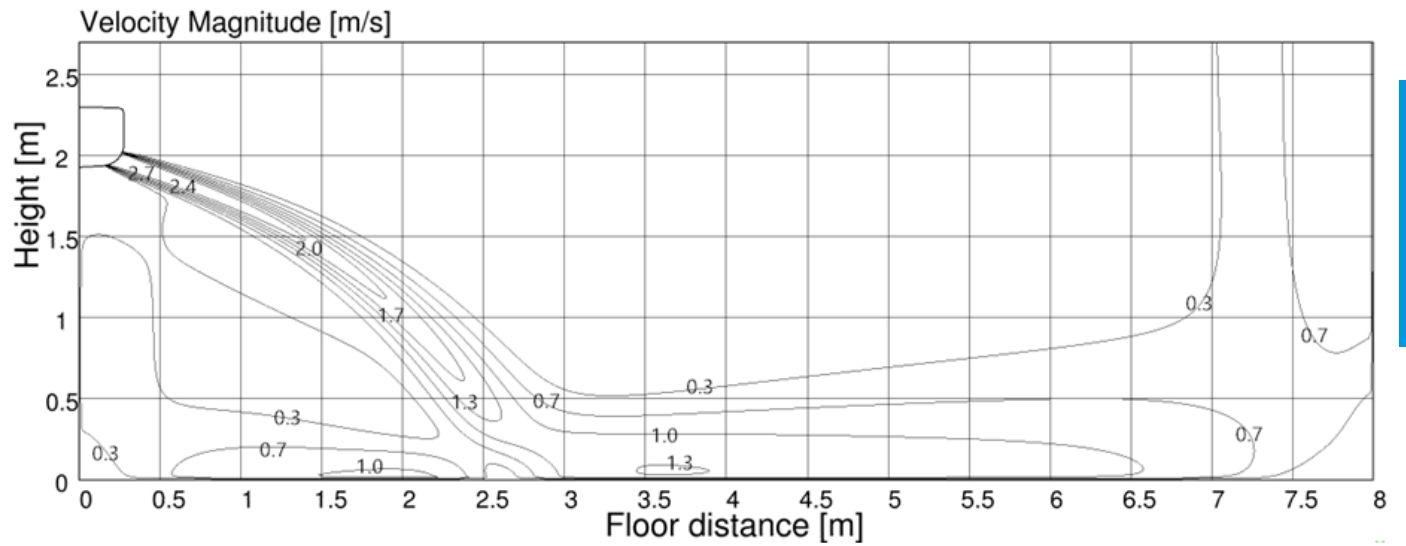

Temperature distributions

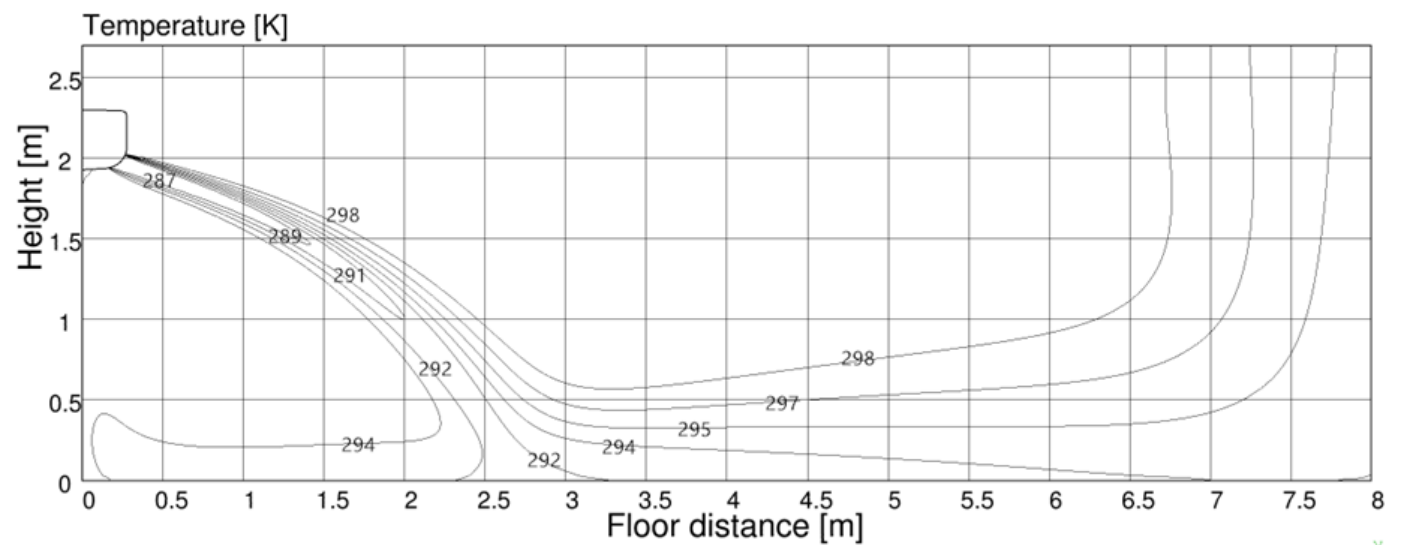

All Easy Pro-30k

Heating(ID: 20°C/68°F, OD: 7°C/44.6°F)

Discharge Angle 100°

Airflow velocity distributions

Velocity Magnitude [m/s]

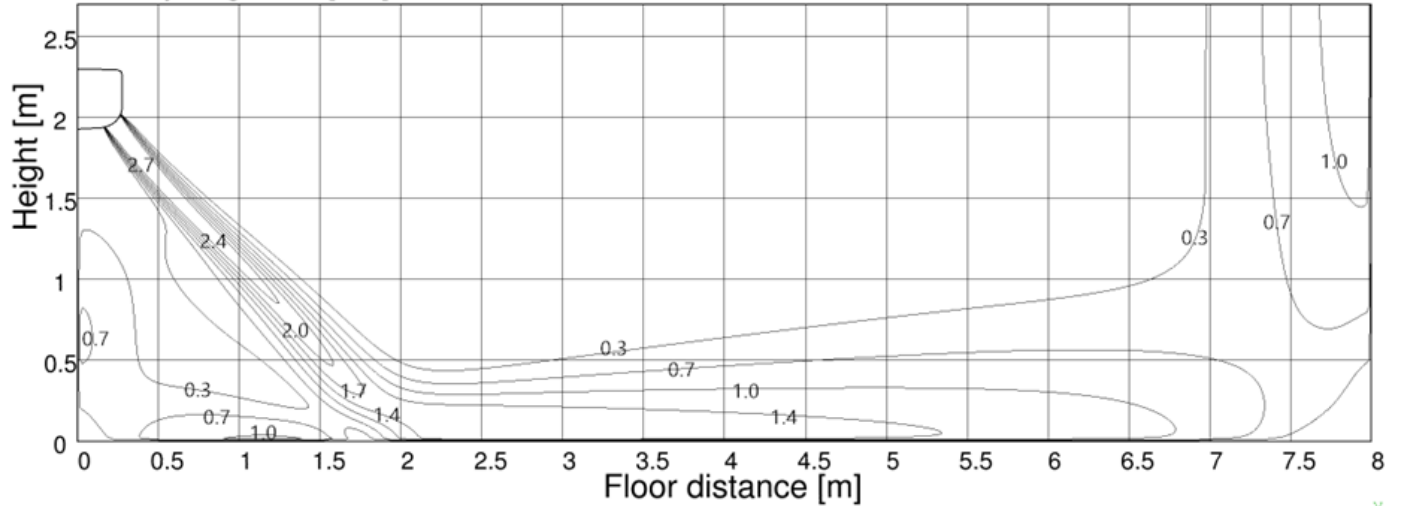

Temperature distributions

Temperature [K]

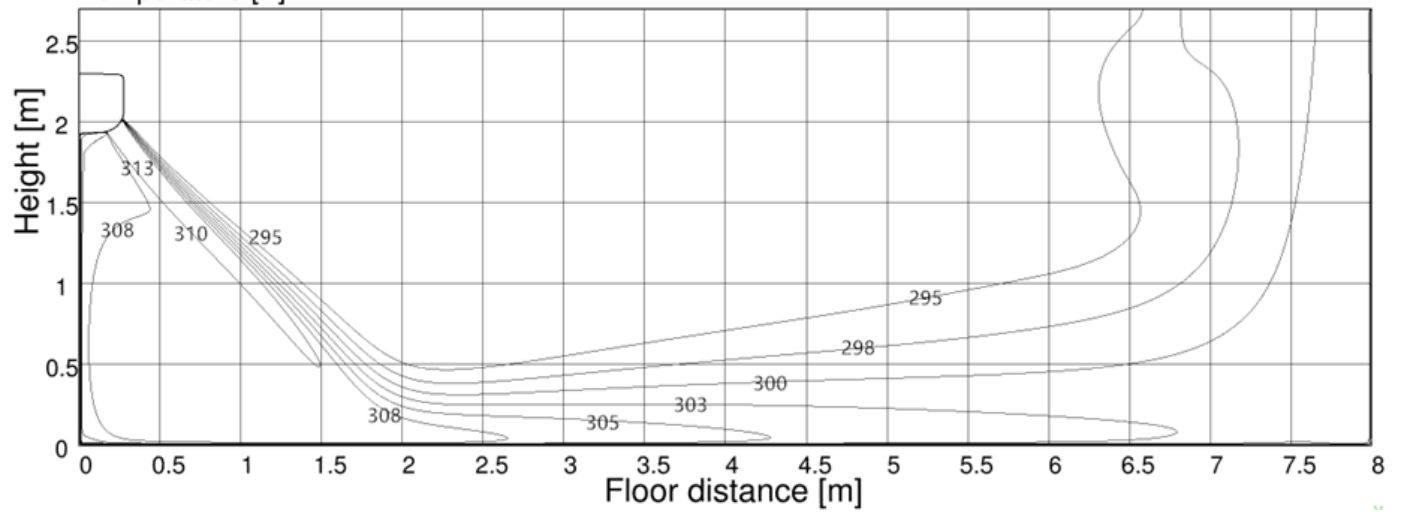

All Easy Pro-36k

Cooling(ID: 27°C/80.6°F, OD: 35°C/95°F)

Discharge Angle 65°

Airflow velocity distributions

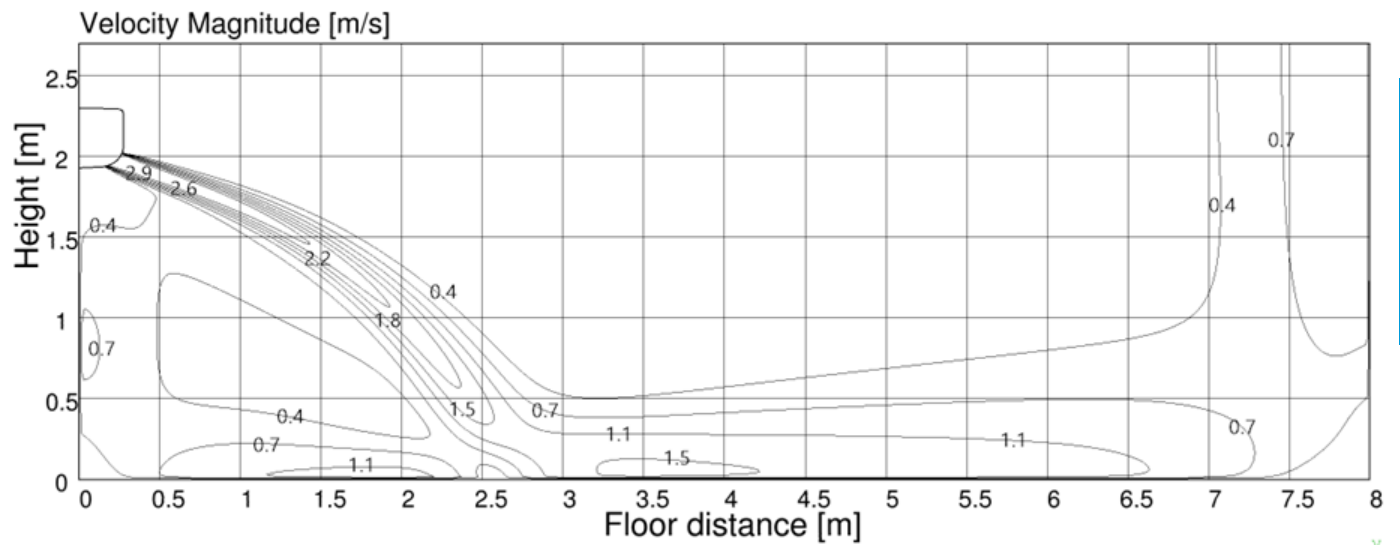

Temperature distributions

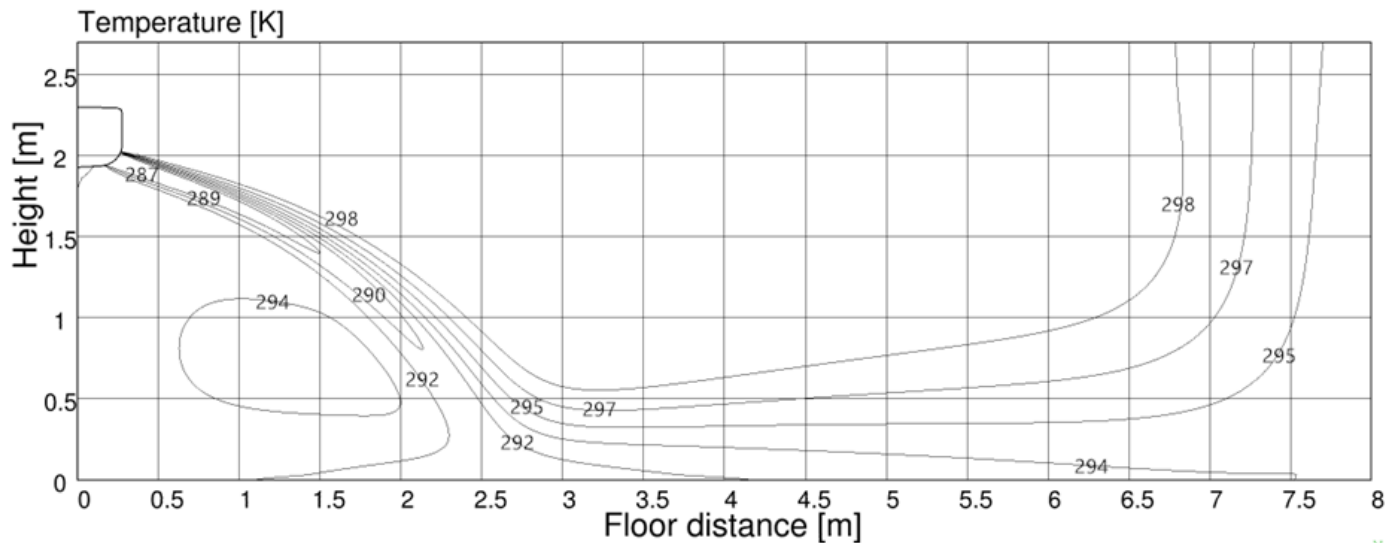

All Easy Pro-36k

Heating(ID: 20°C/68°F, OD: 7°C/44.6°F)

Discharge Angle 100°

Airflow velocity distributions

Velocity Magnitude [m/s]

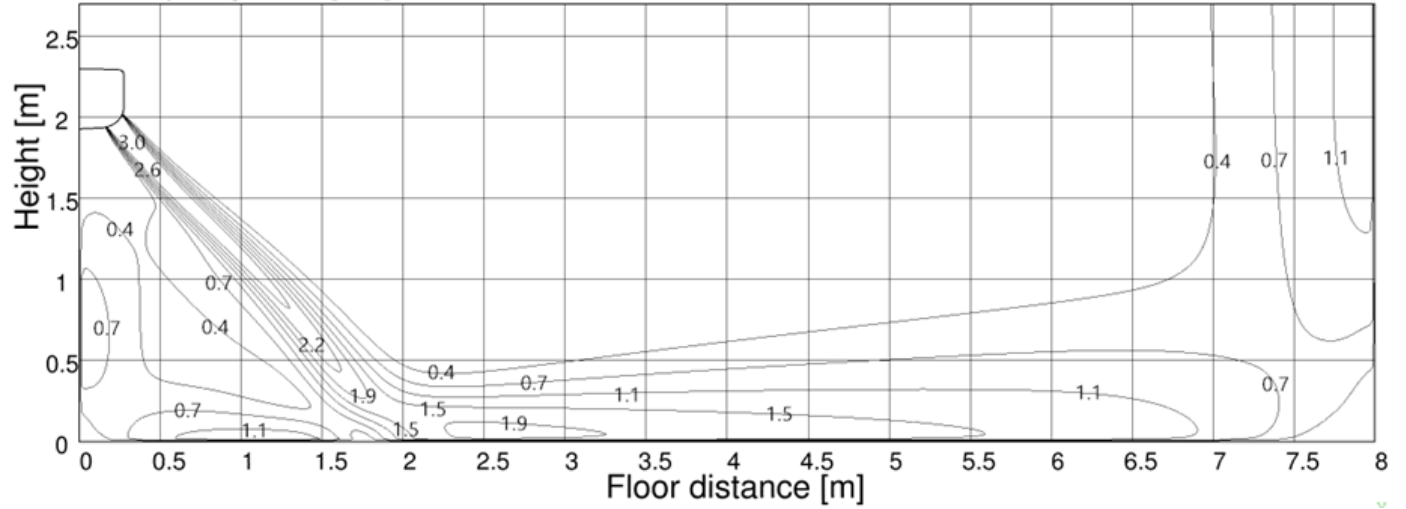

Temperature distributions

Temperature [K]

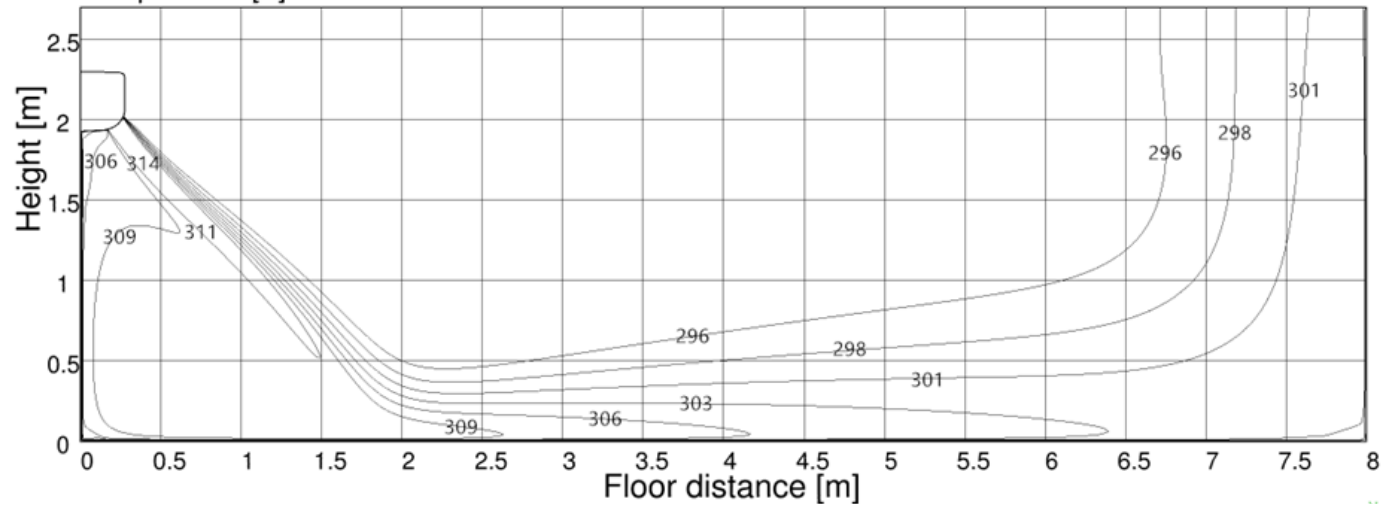

10. Electrical Wiring Diagrams

10.1 Indoor unit

A6 Duct type

MTIU-09HWFN1-M, MTIU-12HWFN1-M, MTIU-18HWFN1-M, MTIU-24HWFN1-M

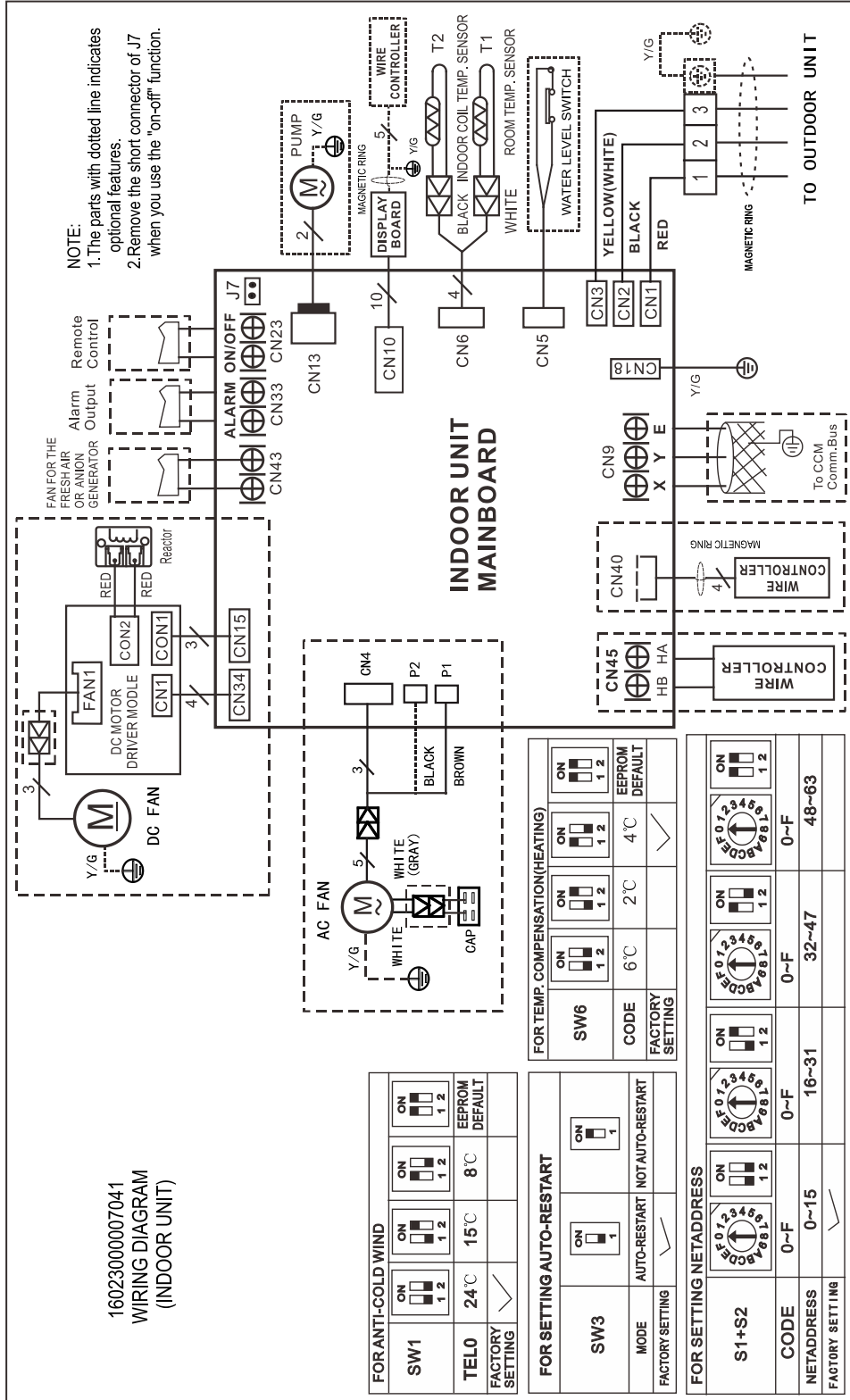

Cassette type:

MCA3U-09HRFN1-M(C), MCA3U-12HRFN1-M(C), MCA3U-18HRFN1-M(C)

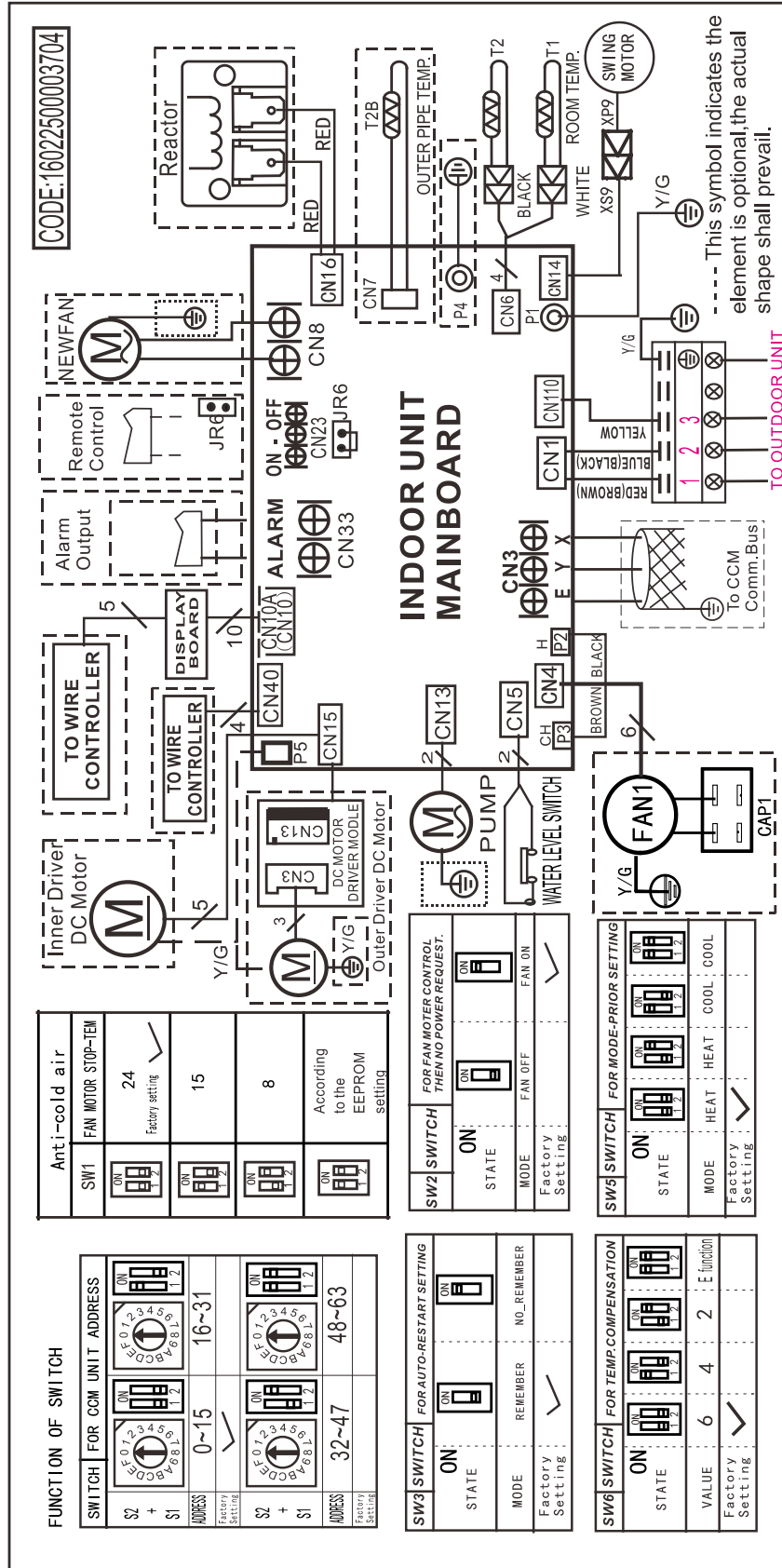

Floor Ceiling type:

MUEU-18HRFN1-M(C), MUEU-24HRFN1-M(C)

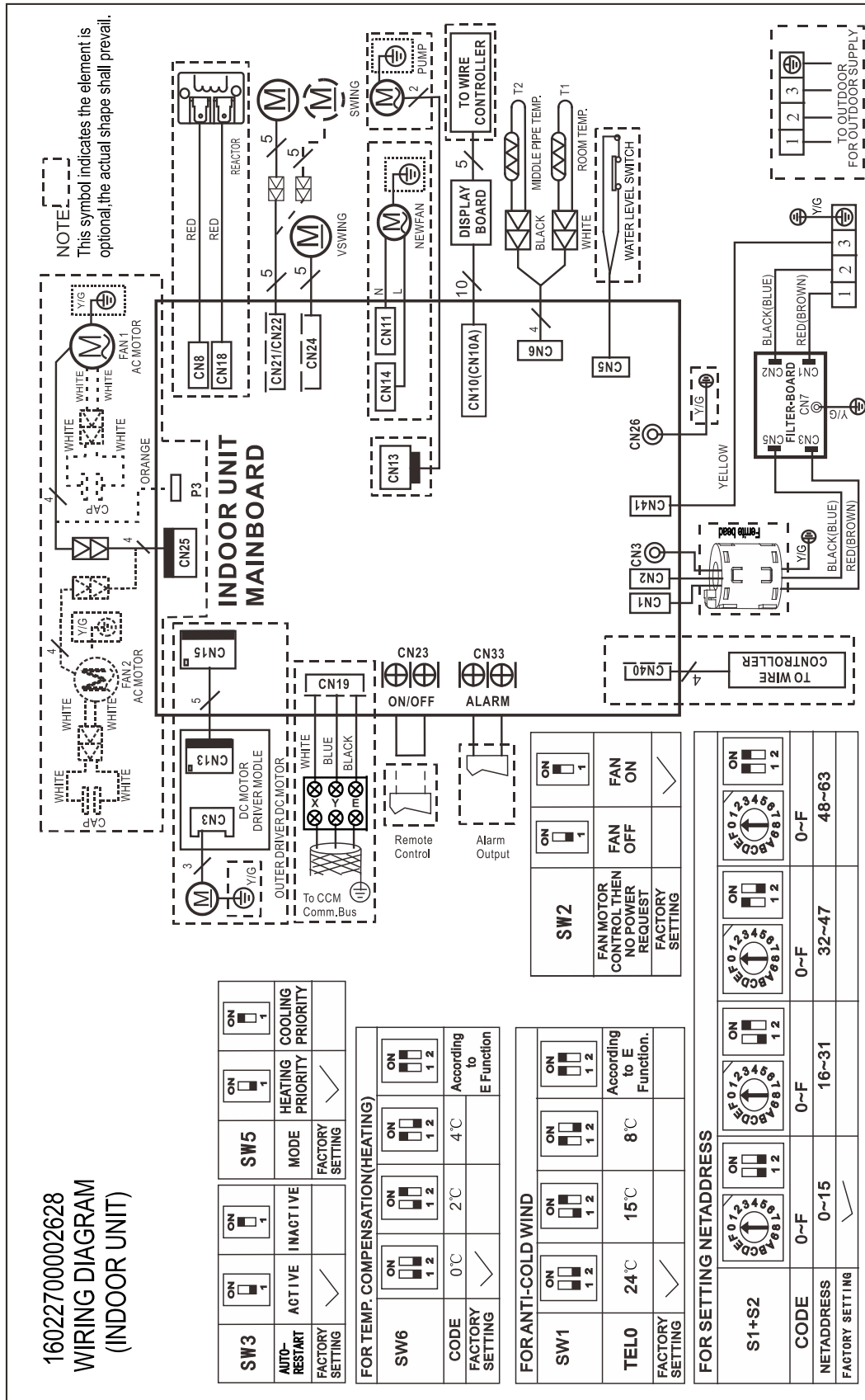

Wall mounted type

MSABB-09HRFN1-MX0W, MSABB-12HRFN1-MV0W, MSABE-18HRFN1-MW5W, MSABE-24HRFN1-MU0W,
MSABF-30HRFN1-MR0W, MSABF-36HRFNX-MQ0W, MSAG11D-18HRFN1-MT8W, MSAG11D-23HRFN1-MU0W,
MSAGF-30HRFN1-MT0W, MSAGF-36HRFNX-MR0W

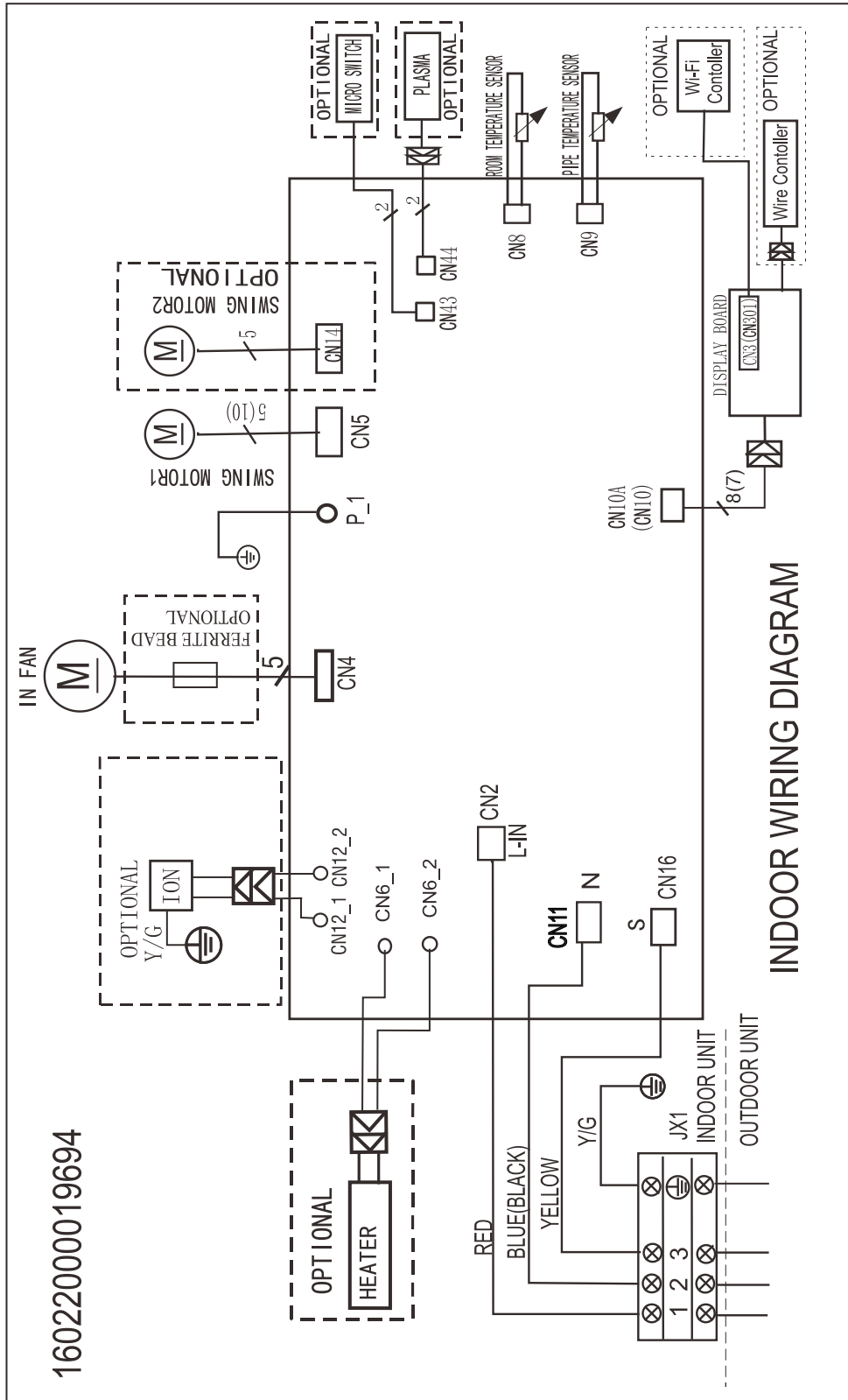

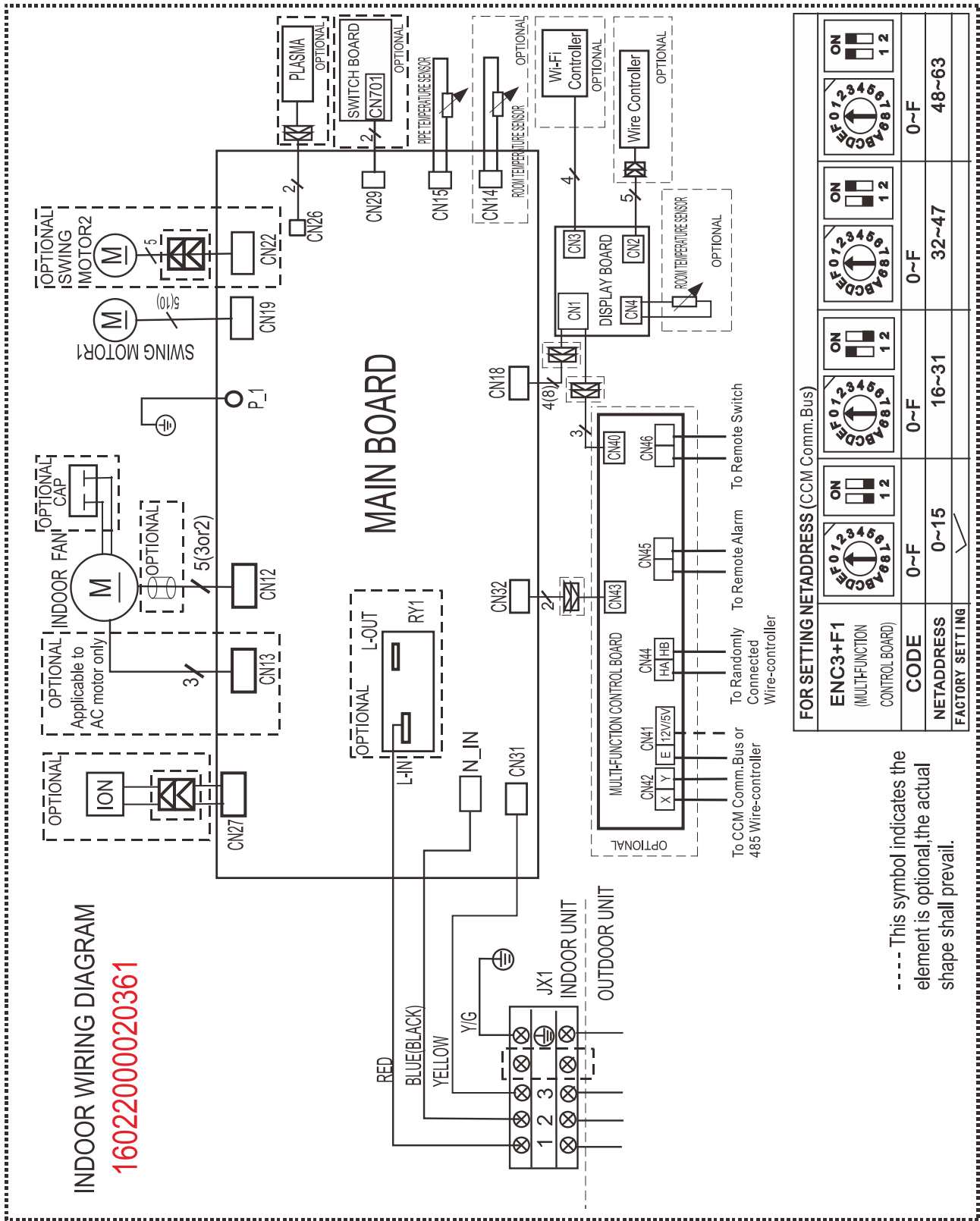

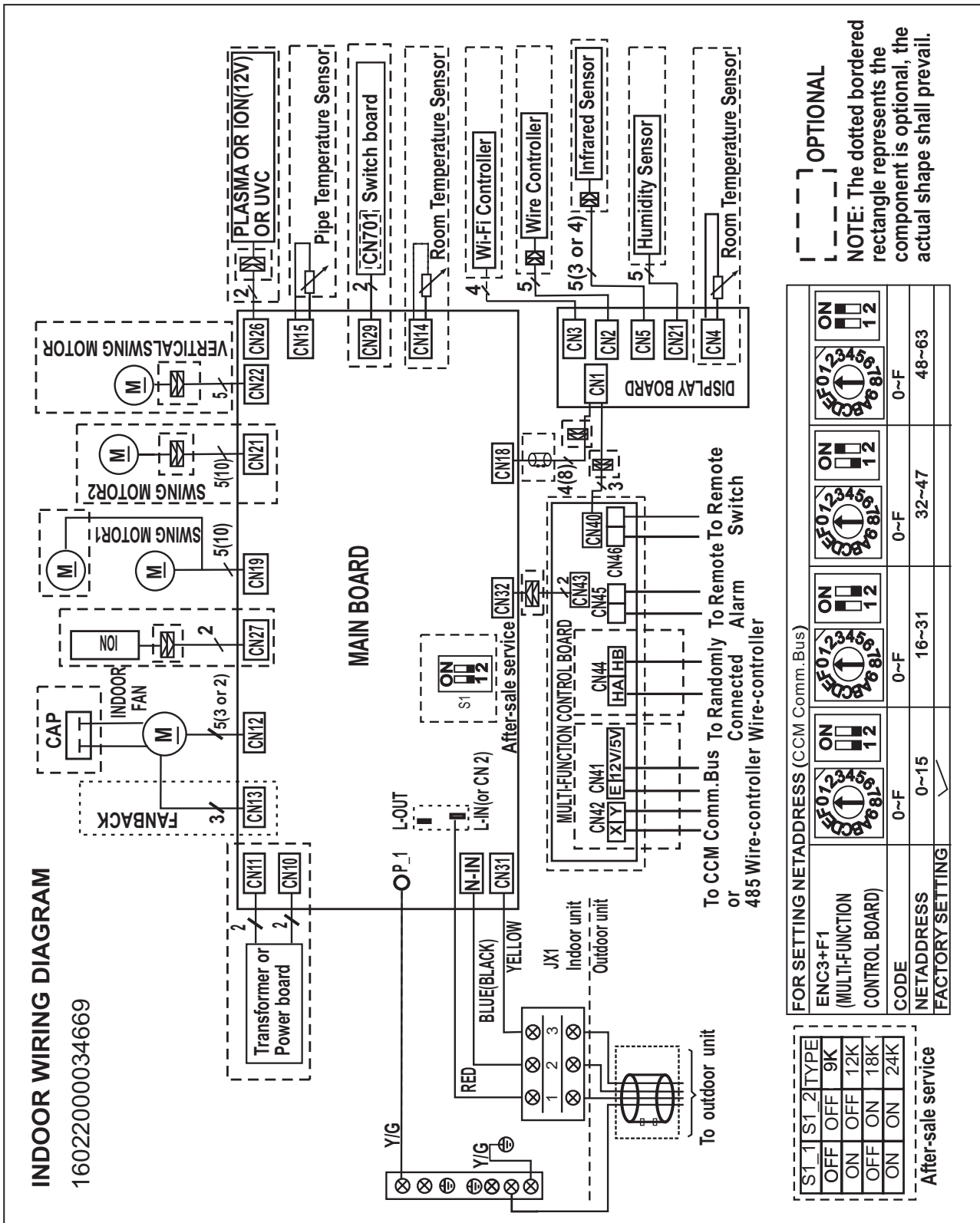

10.2 Outdoor Unit

M20A-18HFN1-M

CODE:16022000035644

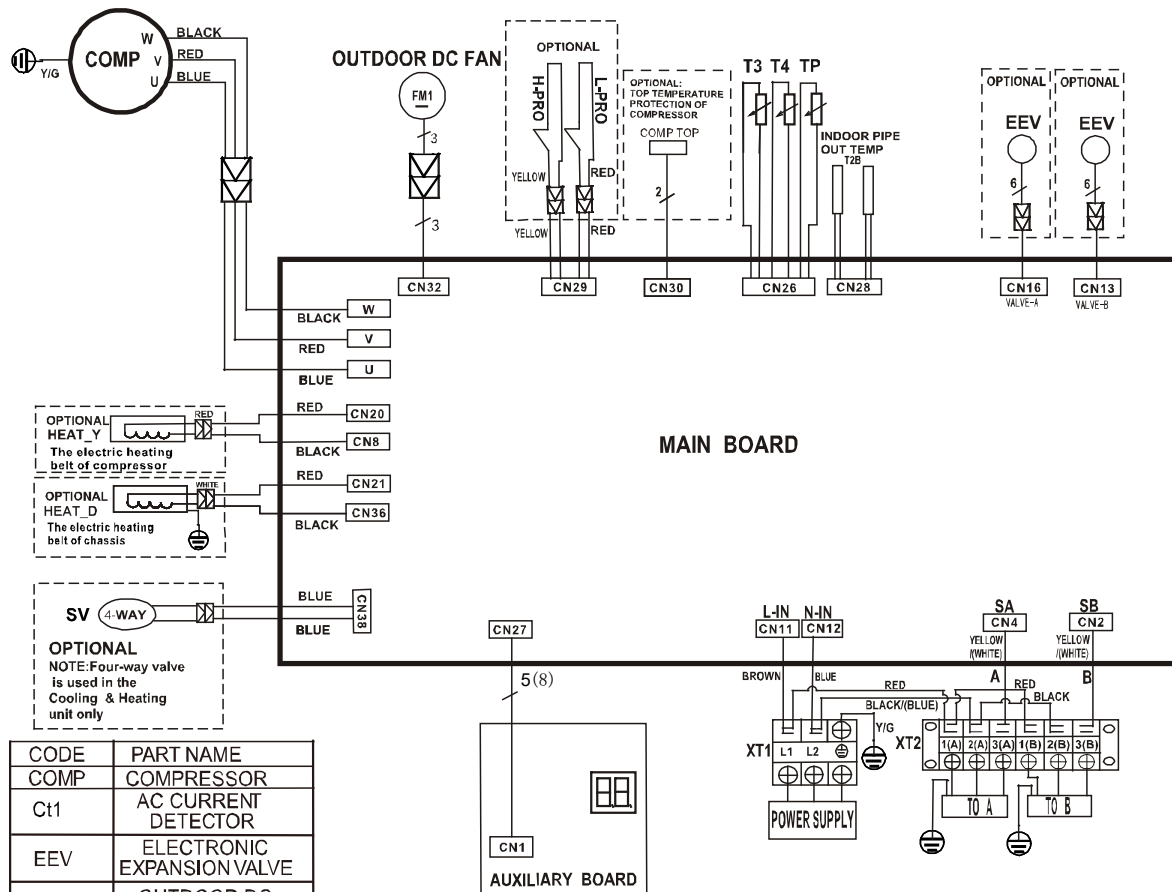

CODE	PART NAME
COMP	COMPRESSOR
Ct1	AC CURRENT DETECTOR
EEV	ELECTRONIC EXPANSION VALVE
FM1	OUTDOOR DC FAN MOTOR
HEAT_D	CHASSIS HEATER
HEAT_Y	CRANKCASE HEATER
H-PRO	HIGH PRESSURE SWITCH
L-PRO	LOW PRESSURE SWITCH
SV	REVERSE VALVE
TP	COMP. DISCHARGE TEMP. SENSOR
T3	COIL TEMP. SENSOR
T4	OUTDOOR AMBIENT TEMP. SENSOR
COMP TOP	COMP. TOP OLP TEMP. SENSOR

Notes:
 This symbol indicates the element is optional, the actual shape shall be prevail.

16022300002514

Notes:

- - - This symbol indicates the element is optional.
- - - the actual shape shall be prevail.

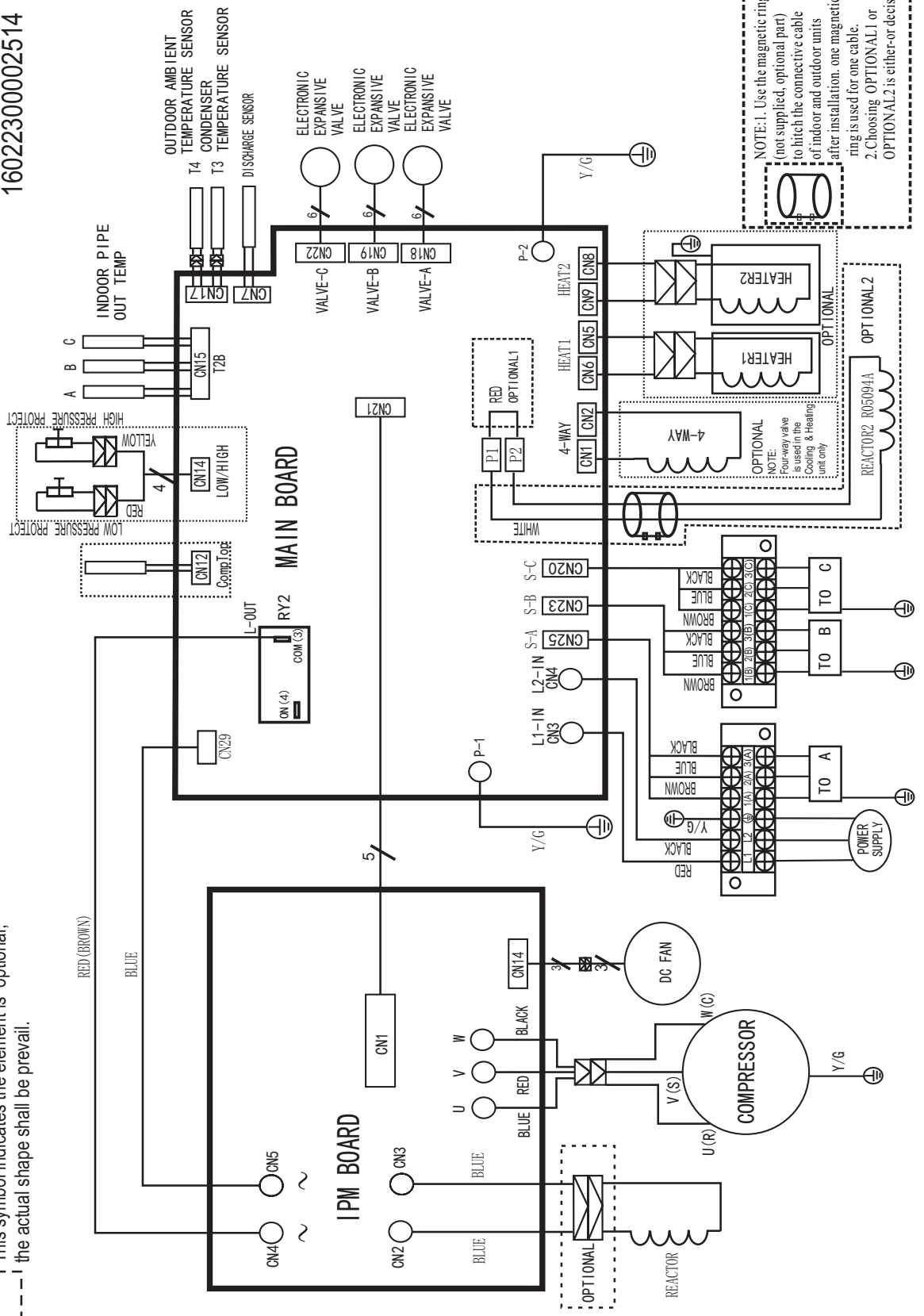

NOTE: 1. Use the magnetic ring (not supplied, optional part) to hitch the connective cable of indoor and outdoor units after installation. one magnetic ring is used for one cable.
 2. Choosing OPTIONAL1 or OPTIONAL2 is either-or decision

NOTE: Four-way valve is used in the Cooling & Heating unit only

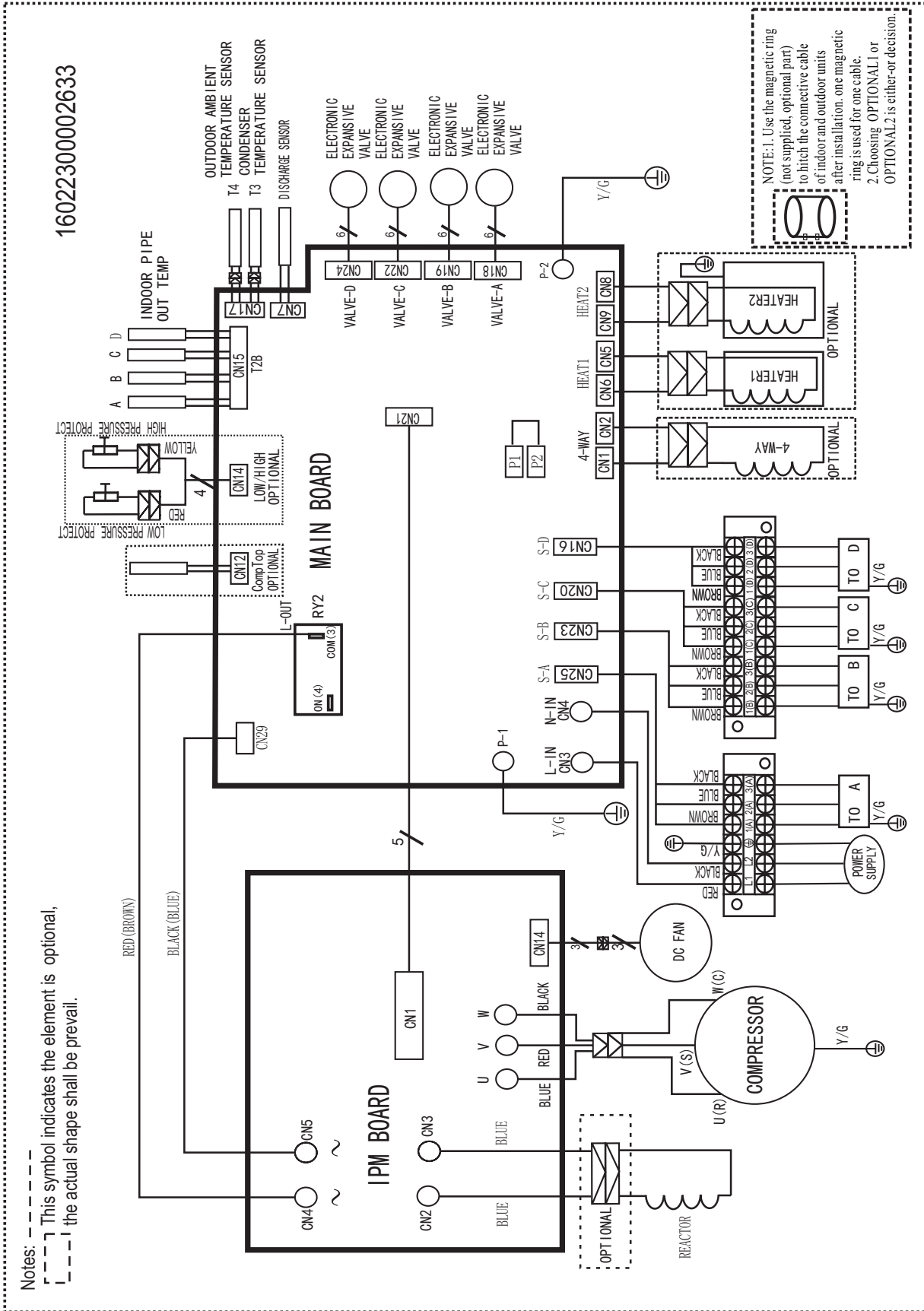

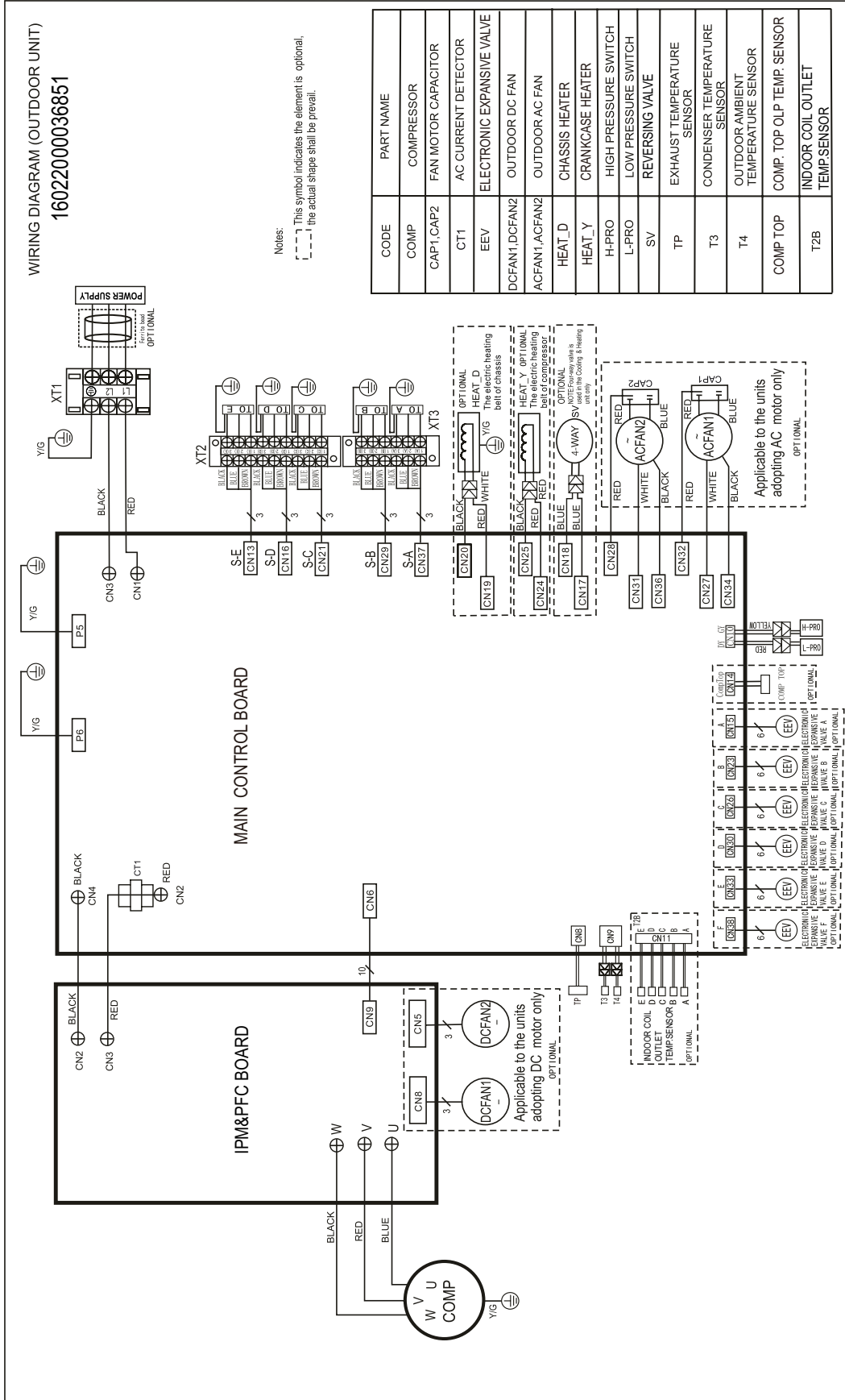

11. Refrigerant Cycle Diagrams

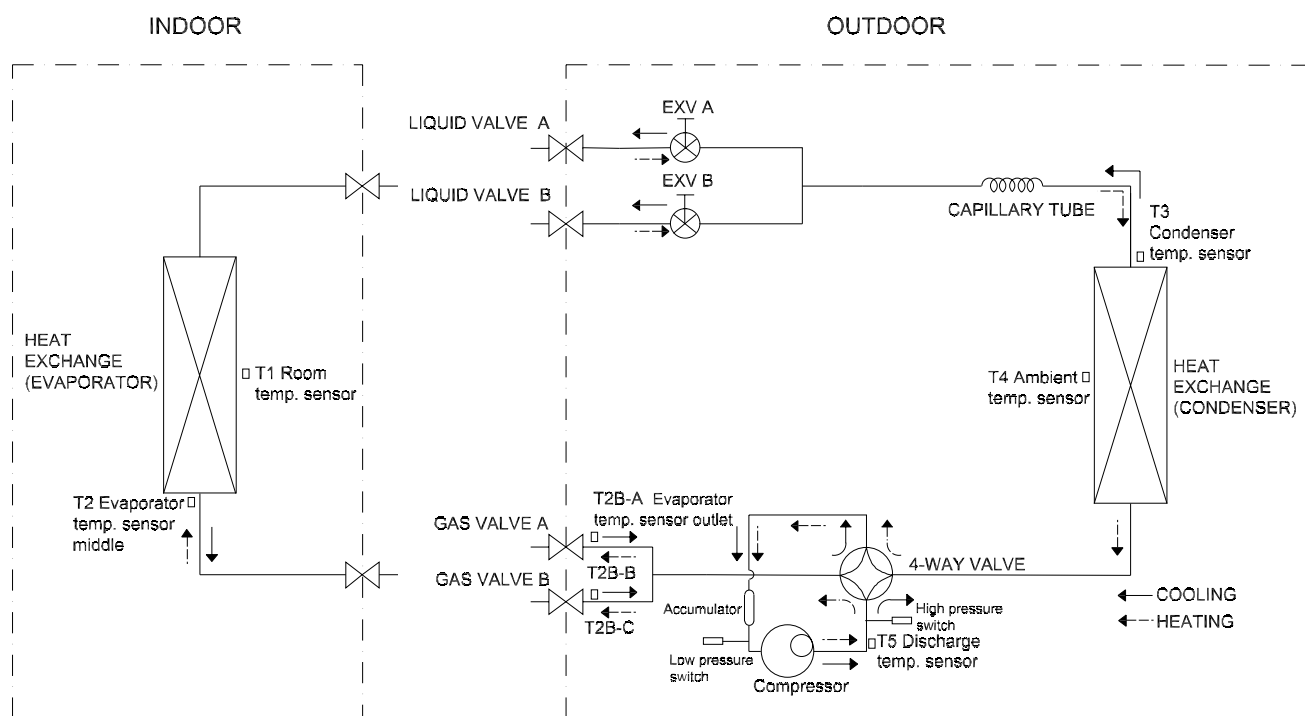

Model	Pipe Size (Diameter:ø)		Piping length (m)			Elevation (m)		Additional Refrigerant
	Gas	Liquid	Rated	Max		IDU and ODU	Between IDUs	
				Single	Total			
M2OA-18HFN1-M	2x9.52	2x6.35	15	25	40	15	10	15g/m

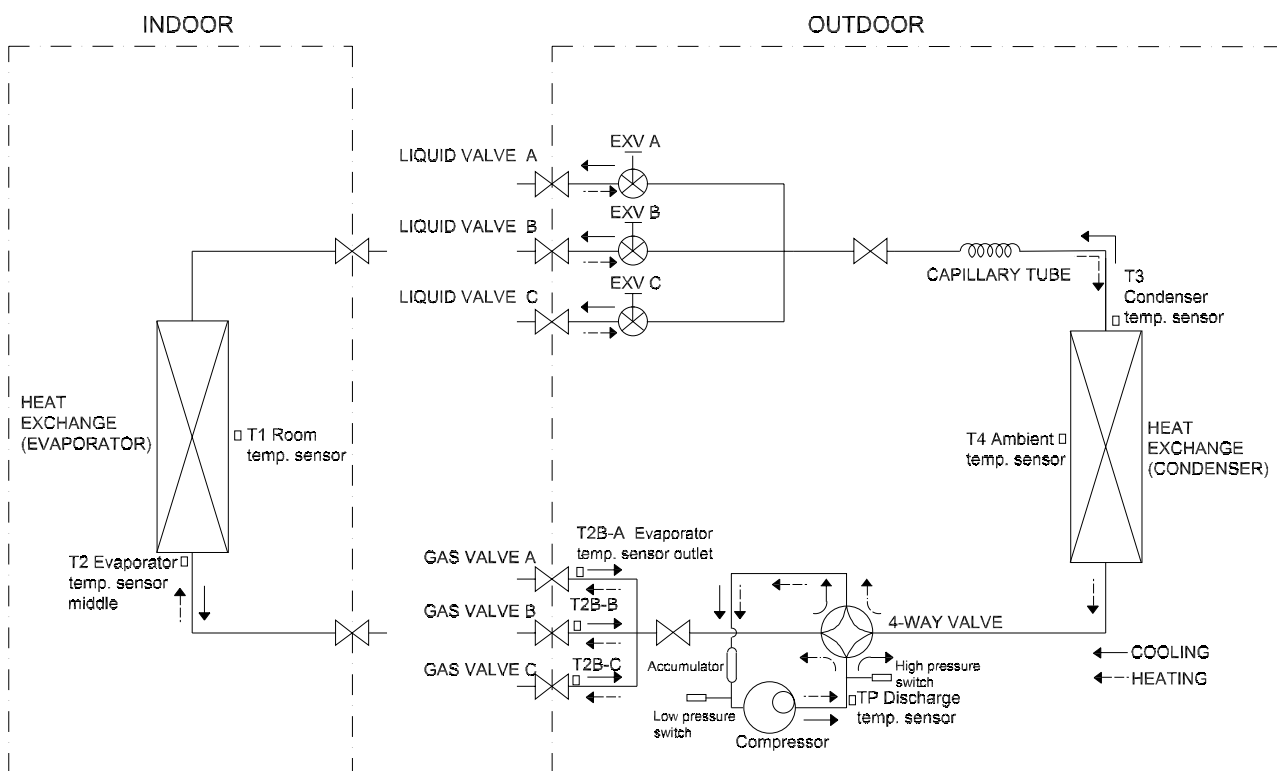

Model	Pipe Size (Diameter:ø)		Piping length (m)			Elevation (m)		Additional Refrigerant
	Gas	Liquid	Rated	Max		IDU and ODU	Between IDUs	
				Single	Total			
M3OJ-27HFN1-M	3x9.52	3x6.35	22.5	30	60	15	10	15g/m

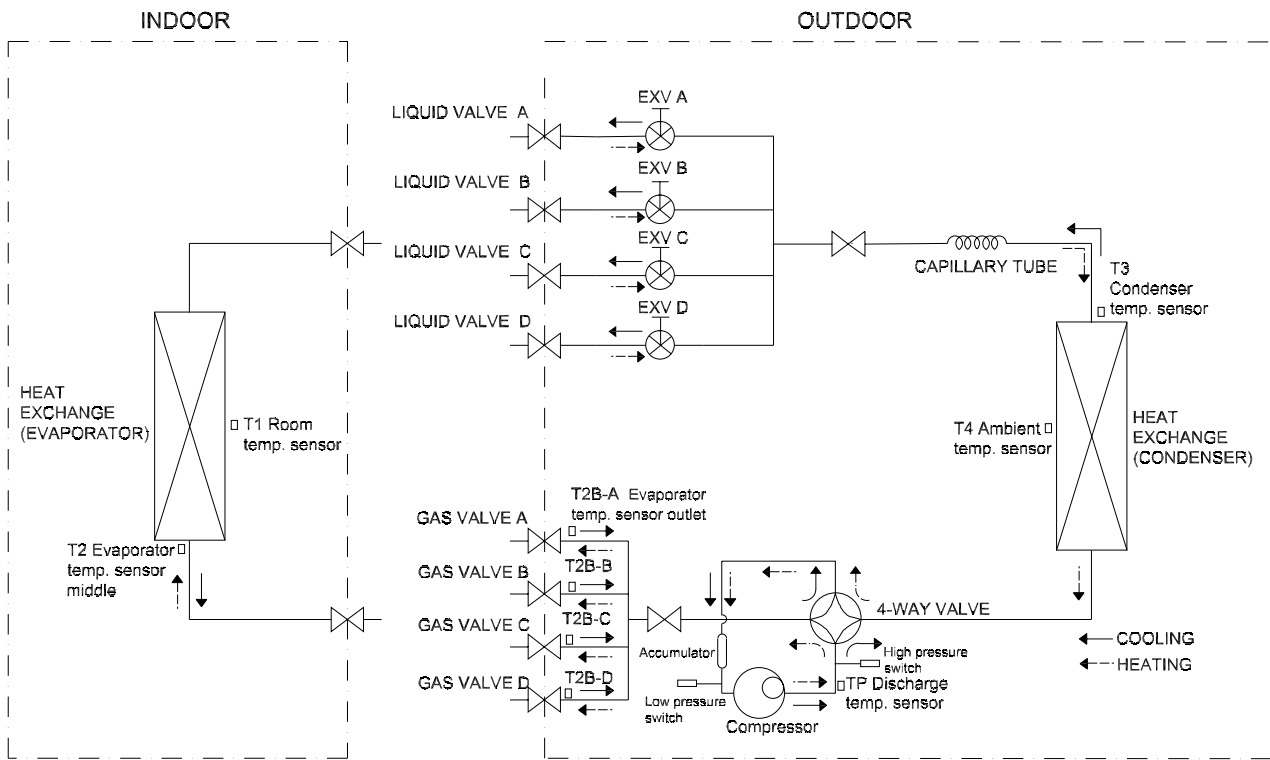

Model	Pipe Size (Diameter:ø)		Piping length (m)			Elevation (m)		Additional Refrigerant
			Rated	Max		IDU and ODU	Between IDUs	
	Gas	Liquid		Single	Total			
M4OG-36HFN1-M	3x9.52+1x12.7	4x6.35	30	35	80	15	10	15g/m

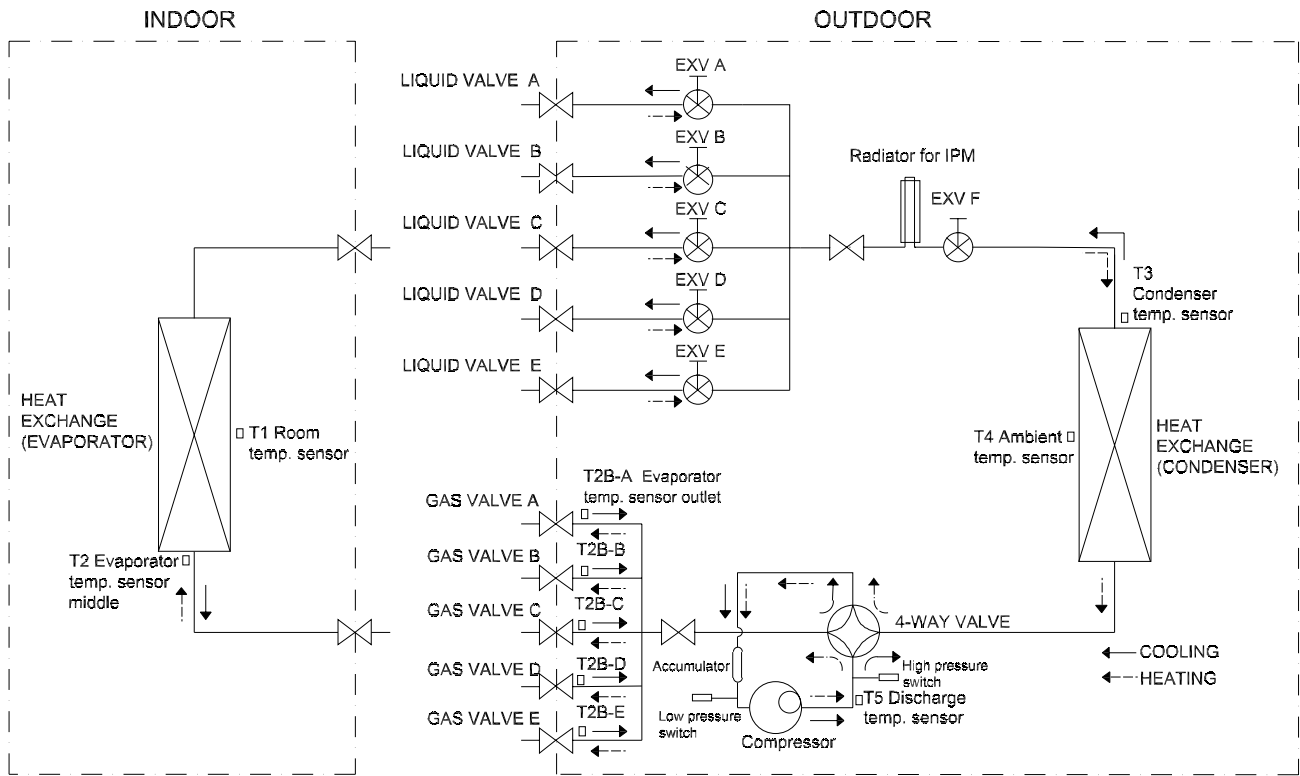

Model	Pipe Size (Diameter:ø)		Piping length (m)			Elevation (m)		Additional Refrigerant
			Rated	Max		IDU and ODU	Between IDUs	
	Gas	Liquid		Single	Total			
M5OG-48HFN1-M	3x9.52+2x12.7	5x6.35	37.5	35	80	15	10	15g/m

12. Capacity Tables

Specifications

Zone	Model	Cooling		Outdoor conditions (DB)*F(°C)																		
		Indoor Conditions *F(°C)		TC	-13 (-25)	-4 (-20)	0 (-17.8)	5 (-15)	17 (-8.3)	25 (-3.9)	35 (1.7)	47 (8.3)	55 (12.8)	65 (18.3)	75 (23.9)	80 (26.7)	85 (29.4)	95 (35)	105 (40.6)	110 (43.3)	115 (46)	122 (50)
		DB	WB																			
Two Zone	MTIU-09HWFN1-M*2 M20A-18HFN1-M	65(18.3)	54(12.2)	TC	19.17	20.20	20.70	21.36	21.58	21.23	21.37	20.36	20.36	20.23	19.72	19.86	19.17	18.85	17.67	16.58	15.74	14.61
				SC	11.98	13.74	14.19	14.77	15.52	15.00	15.95	14.98	15.22	15.65	15.62	15.91	14.91	15.58	14.56	14.98	14.43	14.61
				Input	1.43	1.59	1.74	1.84	1.88	1.82	1.85	1.86	1.88	1.90	1.88	1.88	1.96	2.12	2.05	1.97	2.04	2.13
		70(21.1)	59(15)	TC	20.27	21.25	21.57	22.32	22.67	22.32	22.54	21.55	21.30	21.08	20.80	20.80	20.22	19.95	18.74	17.45	16.70	15.54
				SC	12.60	14.38	14.70	15.35	16.20	15.68	16.73	15.77	15.83	16.21	16.38	16.55	15.62	16.38	15.37	15.69	15.21	15.48
				Input	1.44	1.60	1.70	1.82	1.87	1.82	1.86	1.85	1.88	1.90	1.87	1.88	1.95	2.11	2.04	1.96	2.07	2.14
		75(23.9)	63(17.2)	TC	21.36	22.48	22.61	23.35	23.69	23.35	23.73	22.58	22.30	22.12	21.71	21.82	21.13	20.95	19.52	18.54	17.74	16.32
				SC	13.22	15.11	15.32	15.96	16.83	16.33	17.51	16.44	16.47	16.91	17.01	17.27	16.22	17.11	15.93	16.57	16.07	16.20
				Input	1.44	1.59	1.68	1.80	1.83	1.83	1.85	1.86	1.88	1.88	1.85	1.86	1.95	2.09	2.02	2.00	2.10	2.12
		80(26.7)	67(19.4)	TC	22.65	23.59	23.97	24.32	24.70	24.79	24.90	23.53	23.35	23.18	23.02	22.85	22.38	21.92	20.77	19.73	18.54	17.05
				SC	13.95	15.76	16.16	16.54	17.46	17.23	18.28	17.03	17.14	17.64	17.93	17.98	17.10	17.80	16.84	17.54	16.71	16.85
				Input	1.43	1.59	1.67	1.77	1.82	1.82	1.83	1.85	1.85	1.86	1.87	1.87	2.04	2.07	2.05	2.03	2.07	2.10
Three Zone	MTIU-09HWFN1-M*3 M30J-27HFN1-M	65(18.3)	54(12.2)	TC	25.72	26.67	26.92	26.96	26.66	27.64	27.32	27.41	28.83	29.34	29.30	29.65	27.86	26.55	25.53	24.56	22.50	20.24
				SC	15.97	17.39	17.86	19.10	18.58	19.93	20.05	20.59	21.51	22.13	23.30	23.53	22.07	21.08	21.50	21.67	20.76	20.26
				Input	2.33	2.68	2.82	2.89	2.84	3.06	3.03	3.15	3.38	3.47	3.50	3.54	3.52	3.38	3.40	3.41	3.42	3.40
		70(21.1)	59(15)	TC	27.13	28.20	28.22	28.31	28.09	28.79	29.00	29.13	30.19	30.57	30.88	31.37	29.64	27.92	27.07	25.91	23.49	21.44
				SC	16.75	18.30	18.62	19.96	19.45	20.66	21.18	21.78	22.38	22.94	24.40	24.78	23.37	22.04	22.69	22.75	21.54	21.36
				Input	2.36	2.66	2.78	2.90	2.84	3.05	3.07	3.18	3.36	3.42	3.51	3.60	3.55	3.41	3.44	3.41	3.36	3.43
		75(23.9)	63(17.2)	TC	28.38	29.62	29.89	30.06	29.60	30.30	30.46	30.47	31.71	32.07	32.47	33.38	31.40	29.64	28.26	27.10	24.94	22.52
				SC	17.42	19.11	19.62	21.09	20.39	21.62	22.14	22.68	23.38	23.91	25.51	26.20	24.60	23.28	23.57	23.69	22.76	22.36
				Input	2.35	2.65	2.79	2.91	2.84	3.02	3.09	3.17	3.35	3.39	3.51	3.66	3.53	3.43	3.38	3.35	3.37	3.39
		80(26.7)	67(19.4)	TC	29.65	30.89	31.40	31.84	31.42	31.57	31.73	32.41	33.03	33.62	34.25	34.80	33.08	31.40	29.78	28.26	26.25	23.86
				SC	18.12	19.83	20.51	22.22	21.53	22.38	22.91	23.99	24.25	24.95	26.75	27.18	25.80	24.55	24.72	24.58	23.81	23.57
				Input	2.35	2.62	2.76	2.91	2.89	2.99	3.09	3.20	3.30	3.40	3.50	3.60	3.36	3.42	3.37	3.35	3.39	3.39
Four Zone	MTIU-09HWFN1-M*4 M40G-36HFN1-M	65(18.3)	54(12.2)	TC	33.97	35.31	35.49	35.87	37.89	38.78	41.94	42.08	42.56	42.68	41.96	42.52	38.23	34.36	32.47	31.22	28.28	25.95
				SC	21.82	23.88	23.89	24.66	27.02	27.92	30.35	31.40	32.32	32.63	33.55	33.22	31.04	27.87	26.76	27.42	26.90	25.83
				Input	1.89	2.05	2.14	2.24	2.61	2.72	3.00	3.17	3.29	3.45	3.54	3.77	3.89	4.25	4.16	4.15	4.19	4.25
		70(21.1)	59(15)	TC	35.61	37.25	37.36	37.52	39.55	40.78	43.77	44.16	44.38	45.02	44.35	45.00	39.91	36.06	34.40	32.59	29.70	27.03
				SC	22.73	25.05	25.04	25.66	28.08	29.19	31.48	32.79	33.52	34.26	35.28	34.96	32.23	29.09	28.22	28.49	28.10	26.79
				Input	1.86	2.07	2.16	2.21	2.59	2.70	2.98	3.13	3.23	3.42	3.56	3.82	3.85	4.25	4.19	4.16	4.16	4.17
		75(23.9)	63(17.2)	TC	37.56	39.21	39.45	39.87	41.54	43.33	45.60	46.00	46.37	46.94	46.34	47.12	42.18	38.19	36.32	34.41	31.43	28.19
				SC	23.86	26.25	26.28	27.14	29.36	30.84	32.63	33.96	34.85	35.55	36.63	36.41	33.87	30.67	29.64	29.92	29.55	27.83
				Input	1.84	2.07	2.14	2.26	2.57	2.76	2.94	3.07	3.22	3.38	3.54	3.76	3.91	4.23	4.16	4.14	4.16	4.14
		80(26.7)	67(19.4)	TC	39.38	41.02	41.70	42.28	44.05	45.95	48.10	48.52	48.71	48.90	49.09	49.29	44.88	40.29	38.31	36.26	33.23	29.45
				SC	24.89	27.32	27.65	28.63	30.97	32.54	34.20	35.66	36.43	36.82	38.59	37.90	35.81	32.15	31.11	31.36	31.07	28.95
				Input	1.85	2.05	2.17	2.28	2.60	2.77	2.96	3.07	3.21	3.37	3.54	3.73	4.05	4.24	4.19	4.15	4.19	4.09
Five Zone	MTIU-09HWFN1-M*5 M50G-48HFN1-M	65(18.3)	54(12.2)	TC	39.41	40.58	42.27	42.10	43.90	45.66	45.02	46.24	46.76	47.88	47.86	49.30	45.78	43.77	42.09	39.39	37.18	32.44
				SC	24.69	26.96	27.66	29.84	31.86	33.92	32.96	34.86	35.36	36.26	38.16	38.63	36.05	34.84	34.78	36.03	35.24	32.27
				Input	2.85	3.14	3.37	3.56	3.89	4.14	4.09	4.31	4.42	4.57	4.58	4.70	4.82	5.22	5.33	5.09	5.42	5.67
		70(21.1)	59(15)	TC	41.79	43.03	44.03	44.74	46.16	47.67	47.49	49.19	49.06	50.78	50.06	51.46	47.69	46.03	44.07	41.56	39.38	34.44
				SC	26.06	28.46	28.68	31.54	33.34	35.19	34.56	36.84	36.91	38.22	39.69	40.11	37.39	36.43	36.24	37.79	37.11	34.13
				Input	2.89	3.17	3.37	3.56	3.92	4.07	4.11	4.34	4.41	4.59	4.53	4.63	4.80	5.24	5.25	5.08	5.48	5.65
		75(23.9)	63(17.2)	TC	43.76	44.92	45.96	46.65	48.89	50.23	50.10	51.78	52.03	52.89	53.03	53.60	50.52	48.25	46.73	43.88	41.02	36.33
				SC	27.12	29.55	29.78	32.69	35.16	36.90	36.24	38.54	38.91	39.58	41.81	41.52	39.40	38.00	38.22	39.67	38.43	35.87
				Input	2.88	3.17	3.33	3.50	3.90	4.12	4.13	4.33	4.40	4.54	4.57	4.62	4.79	5.25	5.29	5.10	5.43	5.61
		80(26.7)	67(19.4)	TC	45.63	47.53	48.23	49.00	52.02	52.54	53.18	54.74	55.00	55.27	55.53	55.83	53.68	51.11	48.68	46.00	43.00	38.48
				SC	28.11	31.13	31.06	34.15	37.19	38.35	38.29	40.50	40.92	41.18	43.54	42.99	41.60	40.07	39.63	41.40	40.03	37.79
				Input	2.84	3.16	3.33	3.51	3.98	4.06	4.14	4.39	4.42	4.46	4.50	4.54	5.09	5.23	5.19	5.13	5.39	5.62

LEGEND:

DB --- Dry Bulb

WB --- Wet Bulb

TC --- Total Net Capacity (1000 Btu/h)

SC --- Sensible Capacity (1000 Btu/h)

Input --- Total Power (kW)

Zone	Model	Heating		Outdoor conditions (DB) ¹ F(°C)															
		Indoor Conditions °F(°C)		-13 (-25)	-4 (-20)	0 (-17.8)	5 (-15)	10 (-12.2)	17 (-8.3)	20 (-6.7)	25 (-3.9)	32 (0)	35 (1.7)	40 (4.4)	47 (8.3)	50 (10)	57 (13.9)		
				DB															
Two Zone	MTIU-09HWFN1-M*2 M2OA-18HFN1-M (208-230V)*	60(15.6)	TC	11.58	12.99	13.62	14.21	15.87	17.77	19.18	20.12	21.39	22.33	24.98	27.26	28.09	28.71		
			Input	2.01	1.93	1.86	1.81	1.81	1.78	1.76	1.77	1.77	1.78	1.86	1.98	1.94	1.90		
		65(18.3)	TC	11.29	12.57	13.16	13.74	15.40	17.34	18.53	19.61	20.72	21.79	24.25	26.49	27.22	27.82		
			Input	2.07	1.97	1.90	1.86	1.84	1.83	1.81	1.82	1.81	1.82	1.92	2.03	1.99	1.94		
		70(21.1)	TC	11.01	12.24	12.73	13.30	14.93	16.85	17.92	19.05	20.16	21.17	23.43	25.82	26.50	27.11		
			Input	2.12	2.01	1.95	1.92	1.90	1.87	1.87	1.87	1.86	1.86	1.97	2.09	2.03	1.99		
		75(23.9)	TC	10.62	11.75	12.22	12.71	14.29	16.23	17.29	18.25	19.39	20.22	22.42	24.87	25.39	25.89		
			Input	2.18	2.08	2.01	1.97	1.96	1.92	1.93	1.93	1.92	1.91	2.03	2.15	2.08	2.05		
Three Zone	MTIU-09HWFN1-M*3 M3OJ-27HFN1-M (208-230V)*	60(15.6)	TC	13.65	15.13	15.73	16.47	18.11	19.55	20.84	21.95	23.08	24.21	30.15	36.68	37.72	38.26		
			Input	2.93	2.77	2.71	2.65	2.60	2.51	2.58	2.65	2.67	2.74	2.80	2.95	2.90	2.80		
		65(18.3)	TC	13.26	14.69	15.27	15.96	17.60	18.98	20.23	21.37	22.41	23.57	29.24	35.51	36.62	37.32		
			Input	3.00	2.86	2.80	2.73	2.68	2.57	2.65	2.71	2.75	2.80	2.88	3.03	2.96	2.89		
		70(21.1)	TC	12.83	14.26	14.84	15.50	17.02	18.51	19.64	20.73	21.80	22.86	28.31	34.58	35.48	36.31		
			Input	3.09	2.94	2.86	2.80	2.75	2.64	2.70	2.76	2.81	2.86	2.95	3.12	3.04	2.96		
		75(23.9)	TC	12.32	13.62	14.23	14.85	16.31	17.87	18.78	19.86	20.81	21.85	27.32	33.37	33.89	34.74		
			Input	3.17	3.03	2.95	2.87	2.83	2.72	2.77	2.84	2.91	2.95	3.04	3.22	3.14	3.06		
Four Zone	MTIU-09HWFN1-M*4 M4OG-36HFN1-M (208-230V)*	60(15.6)	TC	21.28	23.33	24.86	25.53	29.49	33.20	33.94	35.29	36.28	37.29	43.50	49.51	51.26	52.04		
			Input	4.39	4.17	4.11	4.01	4.03	3.93	3.84	3.69	3.62	3.54	3.83	4.08	4.00	3.92		
		65(18.3)	TC	20.58	22.74	24.02	24.91	28.57	32.11	33.05	34.09	35.19	36.24	42.44	48.21	49.52	50.33		
			Input	4.50	4.30	4.19	4.09	4.12	4.03	3.93	3.80	3.73	3.62	3.95	4.18	4.10	4.01		
		70(21.1)	TC	19.97	22.18	23.21	24.11	27.77	31.14	32.15	33.17	34.16	35.25	41.17	46.62	47.85	48.96		
			Input	4.64	4.42	4.32	4.21	4.24	4.15	4.02	3.92	3.81	3.70	4.05	4.31	4.21	4.09		
		75(23.9)	TC	19.07	21.27	22.16	23.27	26.71	29.86	30.99	31.71	32.93	33.84	39.56	44.71	46.08	47.10		
			Input	4.77	4.55	4.46	4.32	4.36	4.27	4.16	4.03	3.90	3.80	4.17	4.44	4.35	4.21		
Five Zone	MTIU-09HWFN1-M*5 M5OG-48HFN1-M (208-230V)*	60(15.6)	TC	25.73	28.61	29.52	30.92	35.59	40.08	41.24	41.93	42.80	43.94	51.55	57.13	58.61	60.39		
			Input	5.31	5.00	4.88	4.81	4.74	4.74	4.62	4.56	4.50	4.36	4.63	4.75	4.65	4.50		
		65(18.3)	TC	24.88	27.67	28.80	30.08	34.49	39.10	39.93	40.83	41.60	42.74	49.90	55.68	57.13	58.63		
			Input	5.45	5.16	5.02	4.92	4.85	4.86	4.73	4.65	4.59	4.47	4.74	4.87	4.75	4.59		
		70(21.1)	TC	24.27	26.97	28.10	29.32	33.35	37.82	38.76	39.68	40.58	41.45	48.26	54.06	55.52	56.76		
			Input	5.56	5.30	5.16	5.05	4.98	4.98	4.88	4.79	4.70	4.60	4.87	4.97	4.88	4.73		
		75(23.9)	TC	23.25	25.87	27.06	28.11	32.19	36.46	37.37	38.25	39.04	40.00	46.33	51.79	53.02	54.49		
			Input	5.71	5.46	5.31	5.17	5.12	5.12	5.01	4.92	4.83	4.76	5.02	5.12	5.00	4.86		

LEGEND:

DB --- Dry Bulb

WB --- Wet Bulb

TC --- Total Net Capacity (1000 Btu/h)

Input --- Total Power (kW)

COP --- W/W

13. Noise Criterion Curves

13.1 Indoor Unit

A6 Duct type

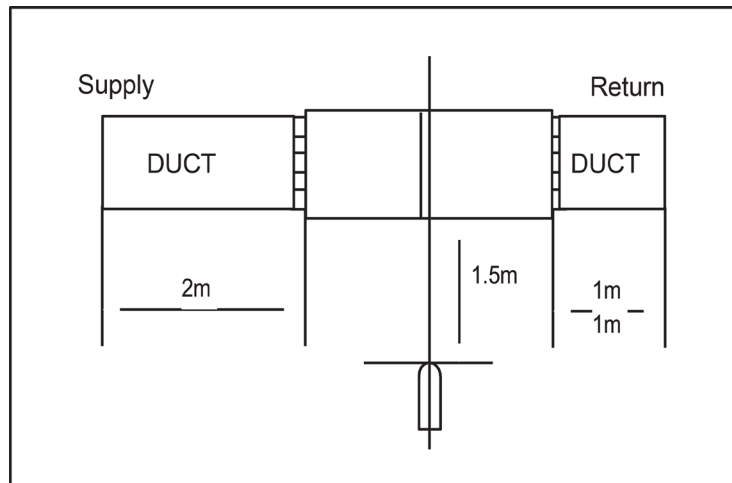

Notes:

- Sound measured at 1.5m away from the center of the unit.
- Data is valid at free field condition
- Data is valid at nominal operation condition
- Reference acoustic pressure $OdB = 20\mu Pa$
- Sound level will vary depending on a range of factors such as the construction -(acoustic absorption coefficient) of particular room in which the equipment is installed.
- The operating conditions are assumed to be standard.

MTIU-09HWFN1-M

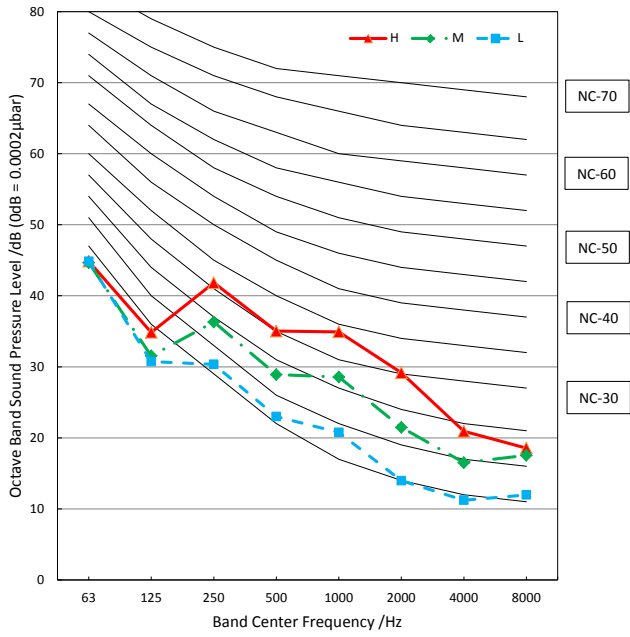

MTIU-12HWFN1-M

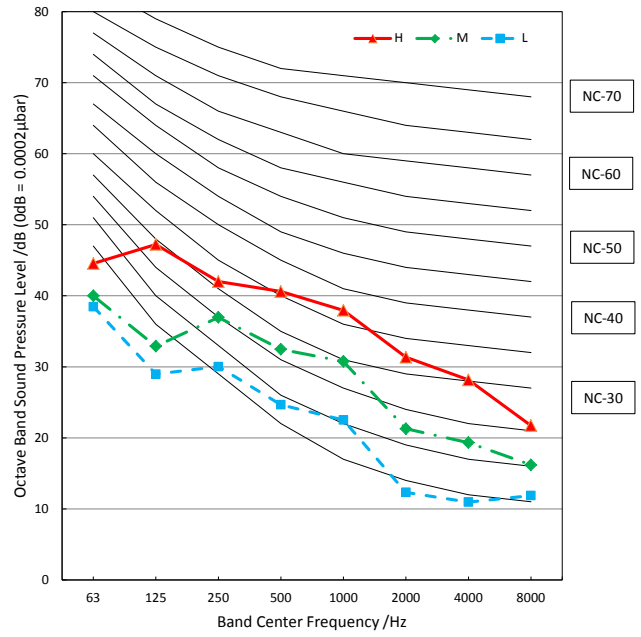

MTIU-18HWFN1-M

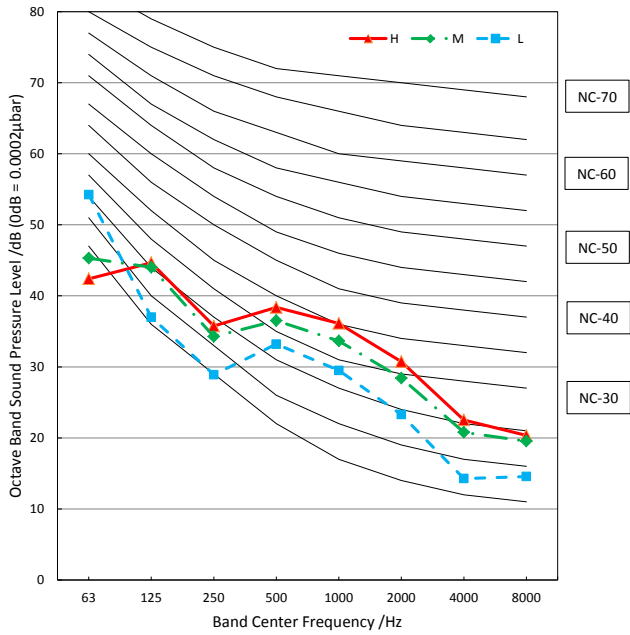

MTIU-24HWFN1-M

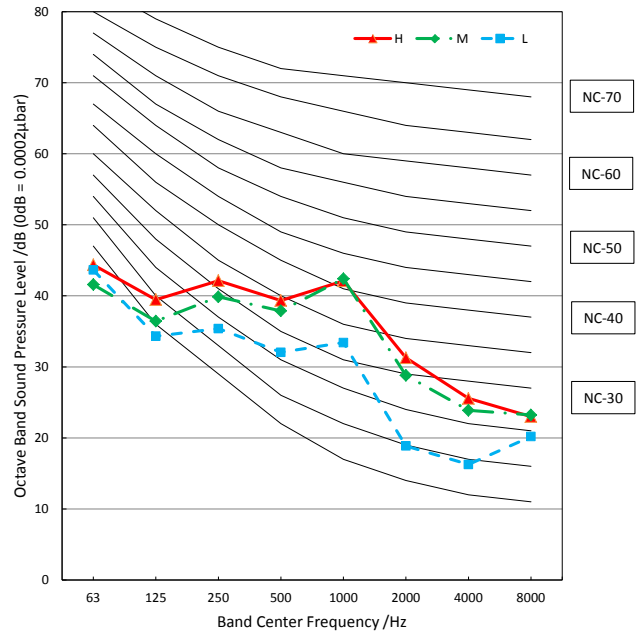

Cassette type

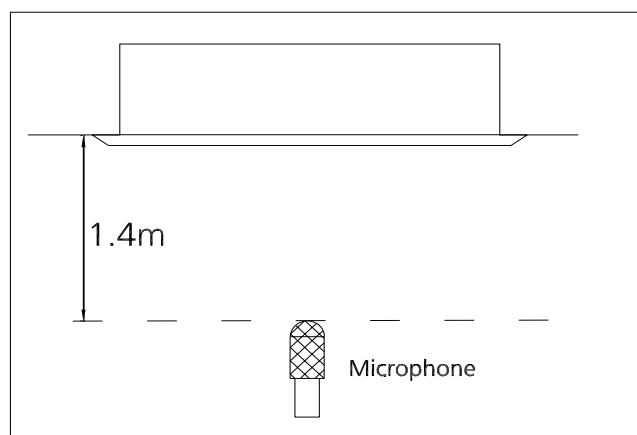

Notes:

- Sound measured at 1.4m away from the noisiest location of the unit.
- Data is valid at free field condition
- Data is valid at nominal operation condition
- Reference acoustic pressure $OdB = 20\mu Pa$
- Sound level will vary depending on a range of factors such as the construction -(acoustic absorption coefficient) of particular room in which the equipment is installed.
- The operating conditions are assumed to be standard.

MCA3U-09HRFN1-M(C)

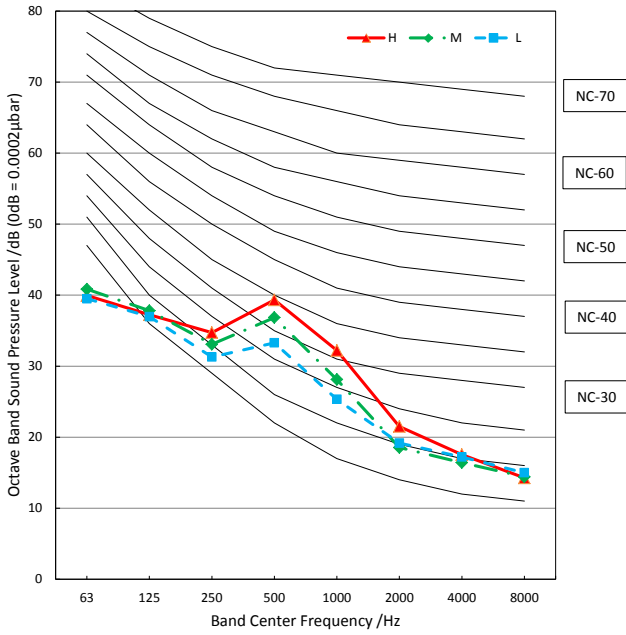

MCA3U-12HRFN1-M(C)

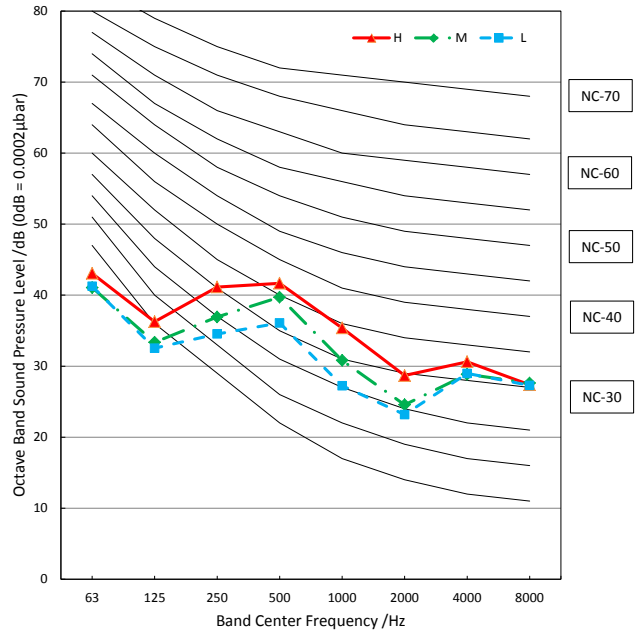

MCA3U-18HRFN1-M(C)

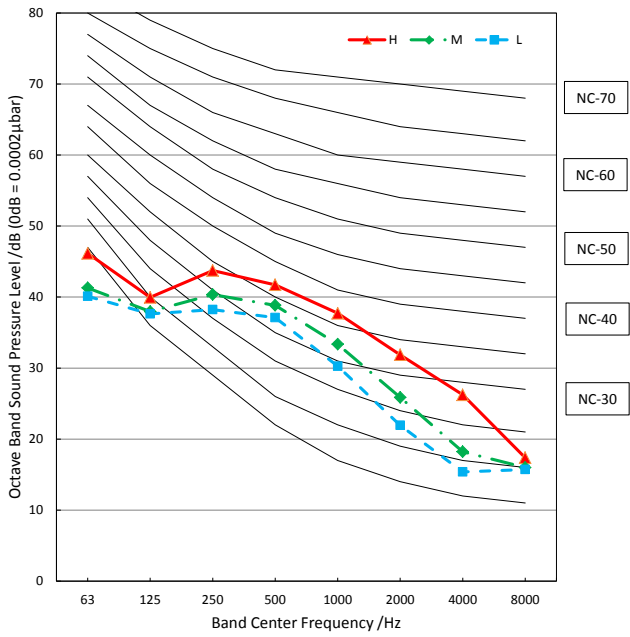

MCD1-24HRFN1-MT0W(GA)

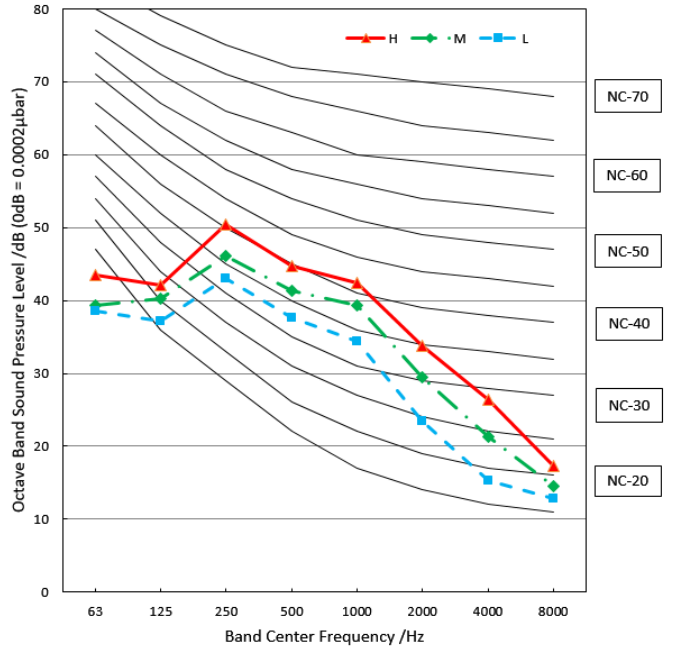

Floor ceiling type

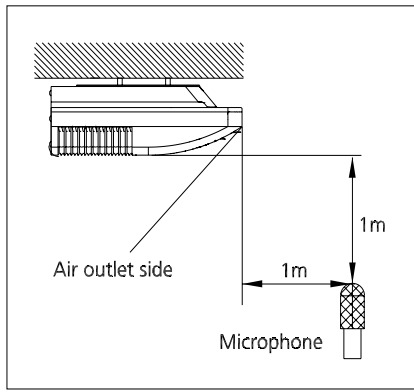

Ceiling



Floor

Notes:

- Sound measured at 1.5m away from the center of the unit.
- Data is valid at free field condition
- Data is valid at nominal operation condition
- Reference acoustic pressure $OdB = 20\mu Pa$
- Sound level will vary depending on a range of factors such as the construction -(acoustic absorption coefficient) of particular room in which the equipment is installed.
- The operating conditions are assumed to be standard.

MUEU-18HRFN1-M(C)

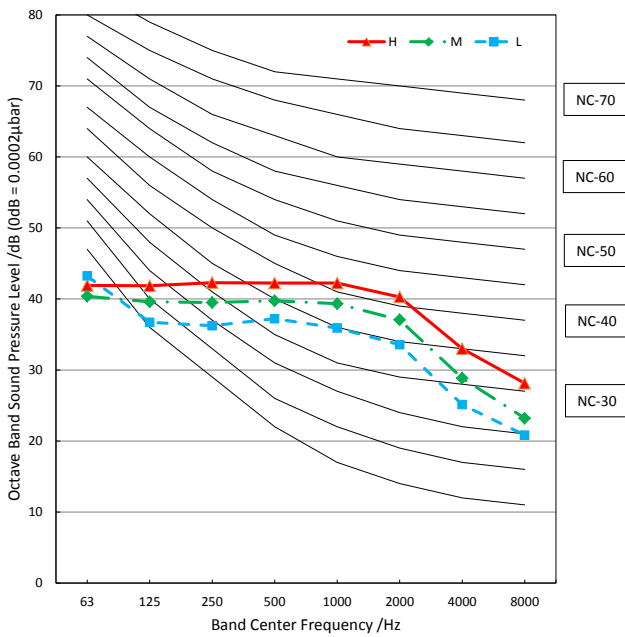

MUEU-24HRFN1-M(C)

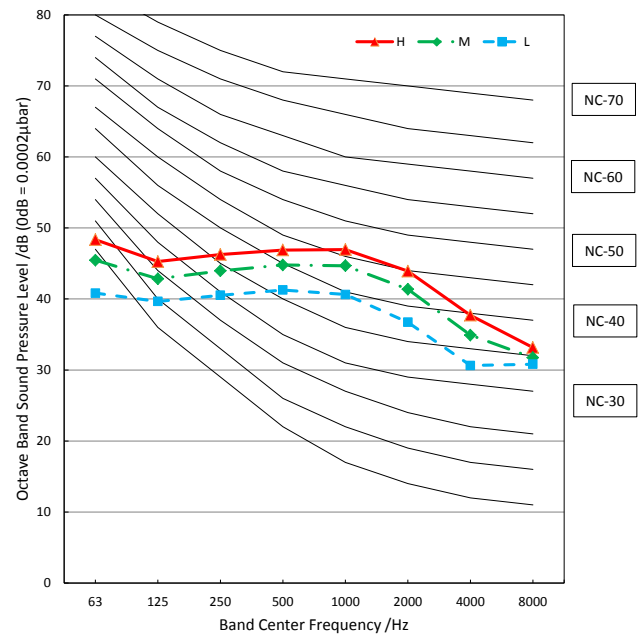

Air Handler Type

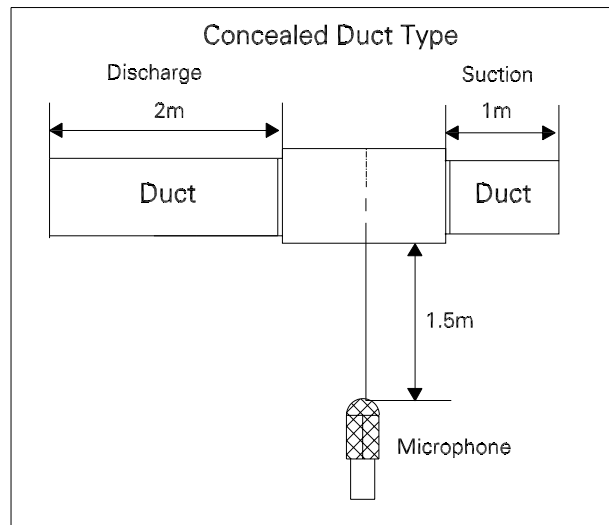

Notes:

- Sound measured at 1.5m away from the center of the unit.
- Data is valid at free field condition
- Data is valid at nominal operation condition
- Reference acoustic pressure $OdB = 20\mu Pa$
- Sound level will vary depending on a range of factors such as the construction -(acoustic absorption coefficient) of particular room in which the equipment is installed.
- The operating conditions are assumed to be standard.

MVC-18HWFN1-MW(GA)

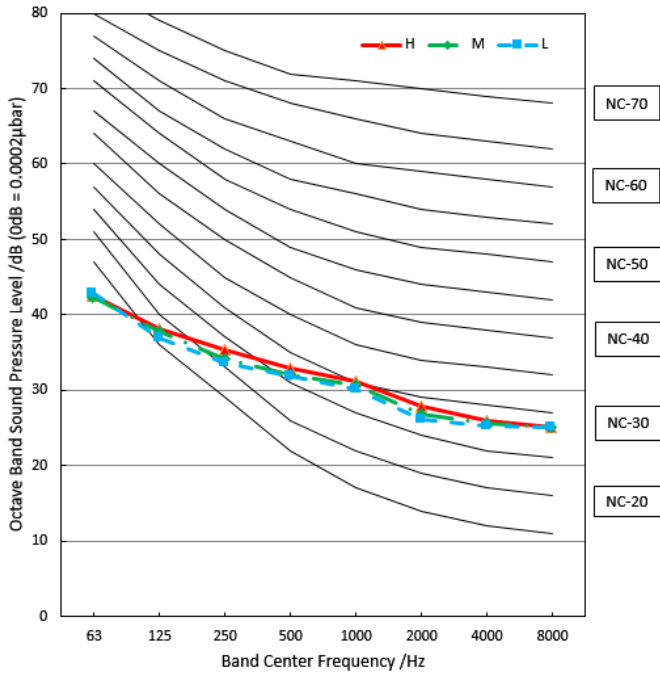

MVC-23HWFN1-M

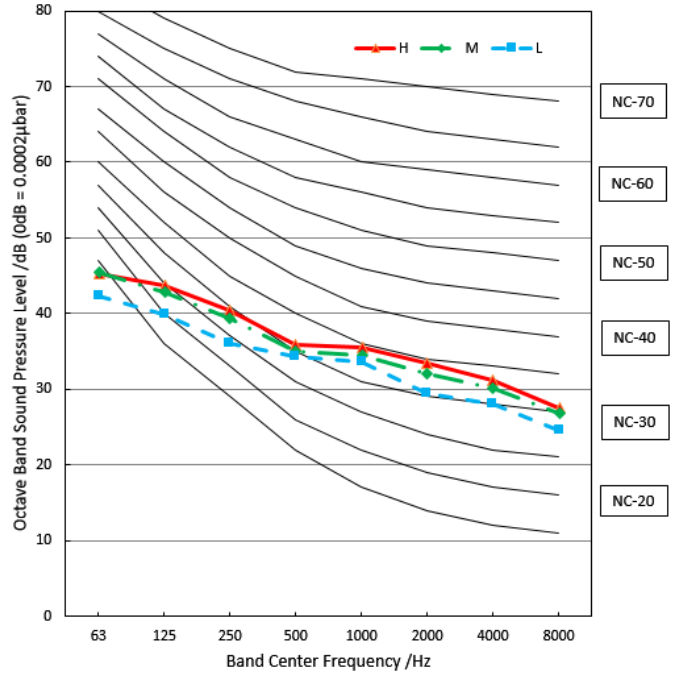

MVC-30HWFN1-M(GA)

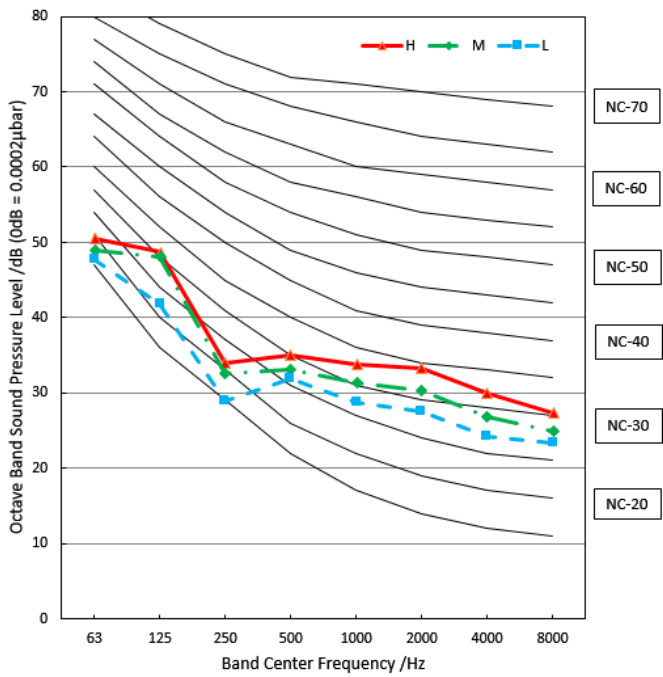

MVCU-36HWFN1-M(GA)

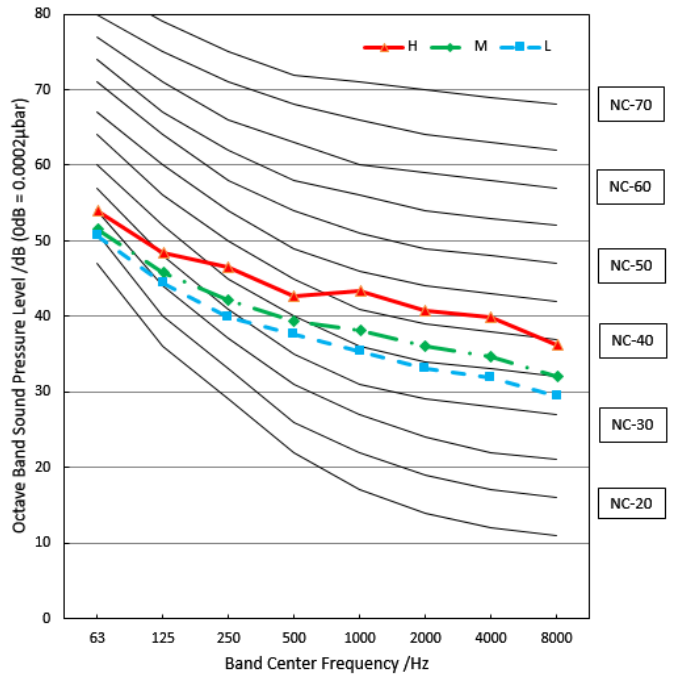

Wall mounted type

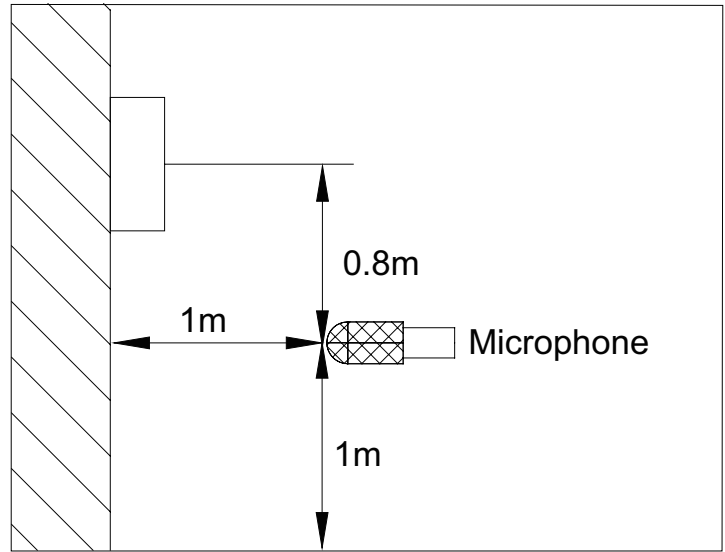

Notes:

- Sound measured at 1.0m away from the center of the unit.
- Data is valid at free field condition
- Data is valid at nominal operation condition
- Reference acoustic pressure $OdB = 20\mu Pa$
- Sound level will vary depending on a range of factors such as the construction -(acoustic absorption coefficient) of particular room in which the equipment is installed.
- The operating conditions are assumed to be standard.

MSABB-09HRFN1-MX0W

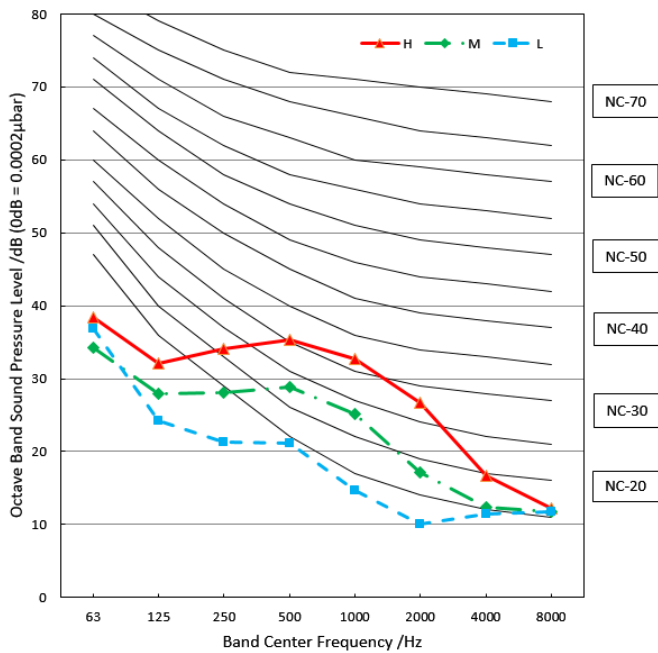

MSABB-12HRFN1-MV0W

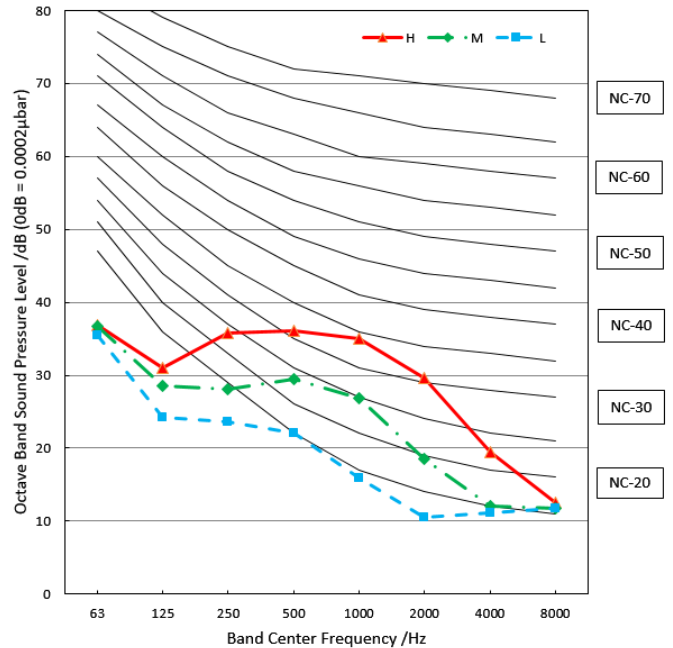

MSABE-18HRFN1-MW5W

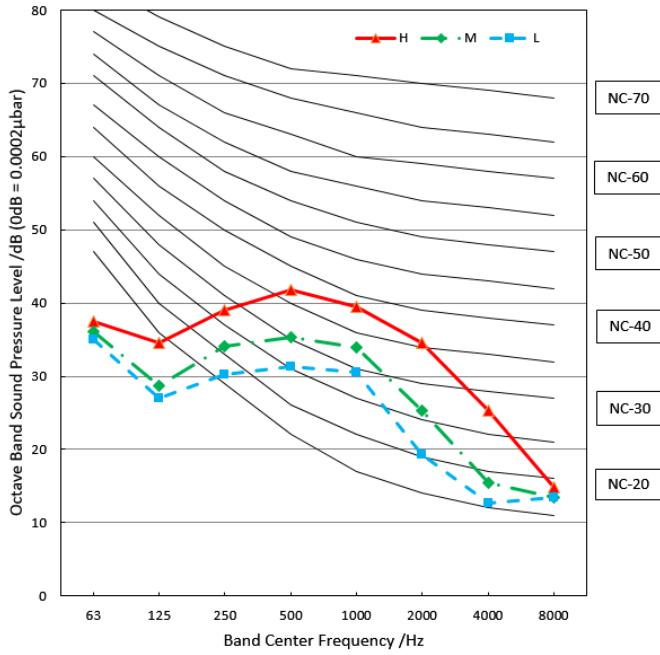

MSABE-24HRFN1-MU0W

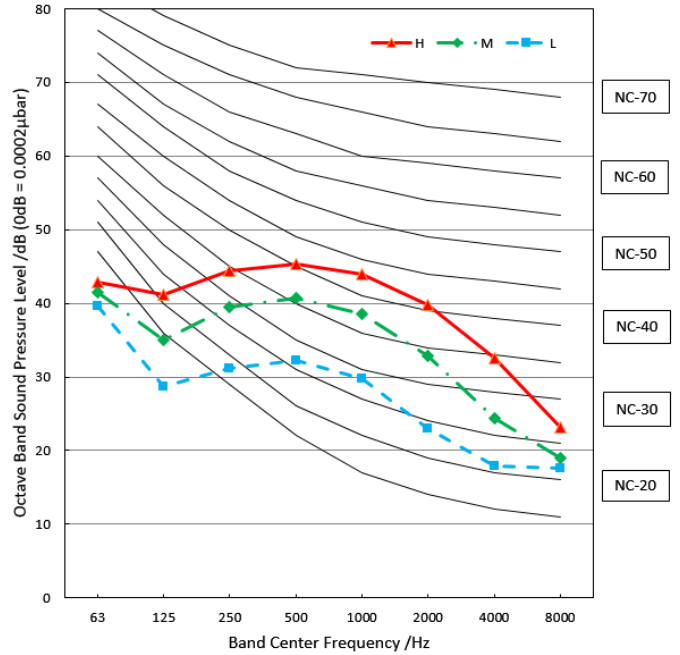

MSABF-30HRFN1-MROW

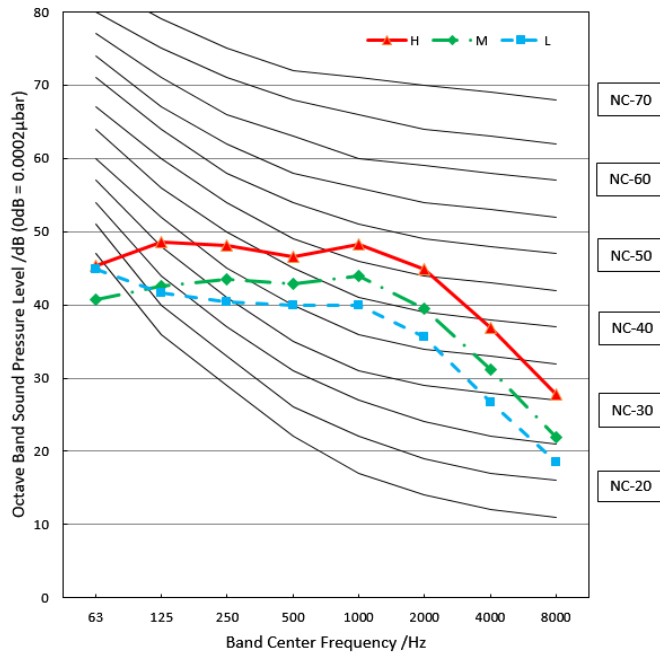

MSABF-36HRFNX-MQ0W

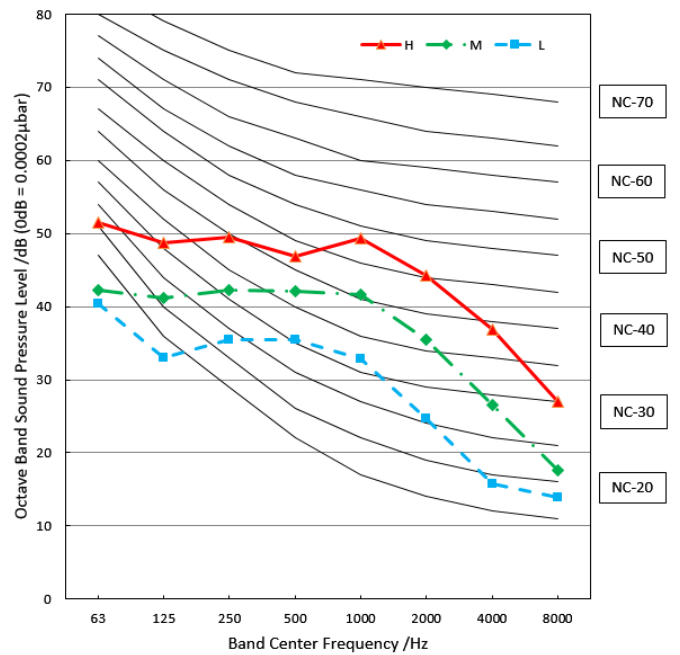

MSAG11A-06HRFN1-MU0W

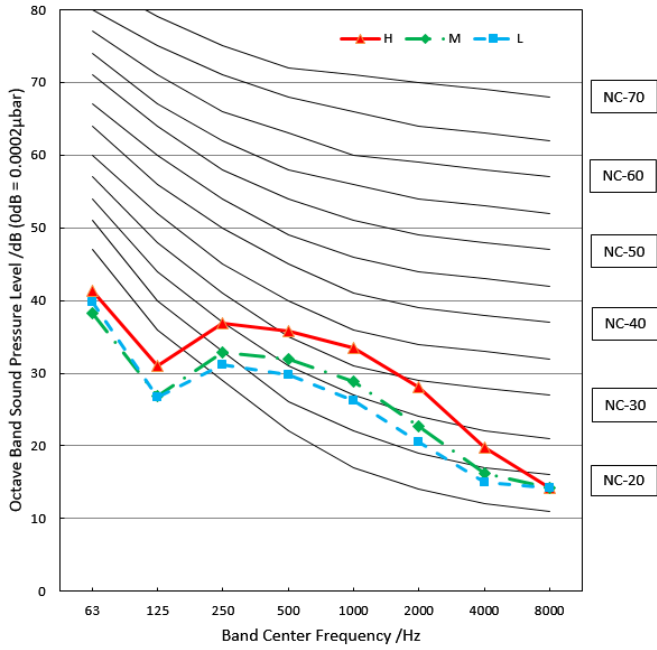

MSAG11B-09HRFN1-MX7W(GA)

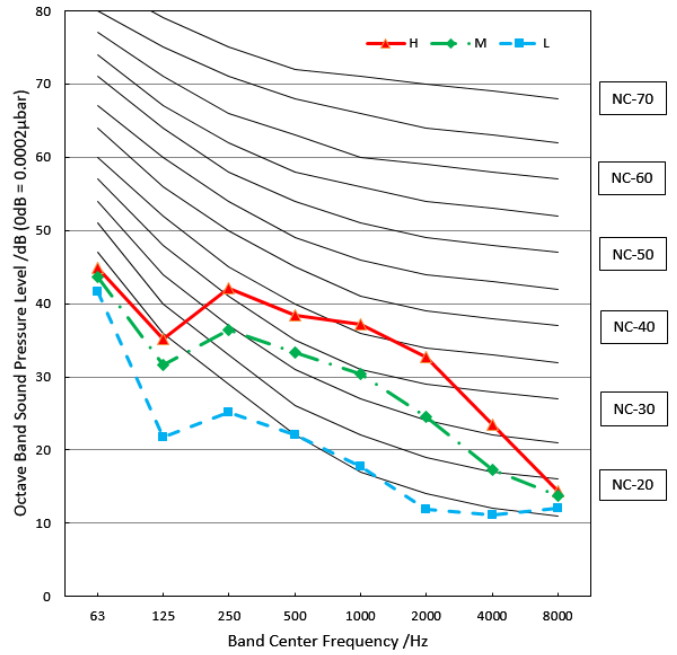

MSAG11B-12HRFN1-MV0W(GA)

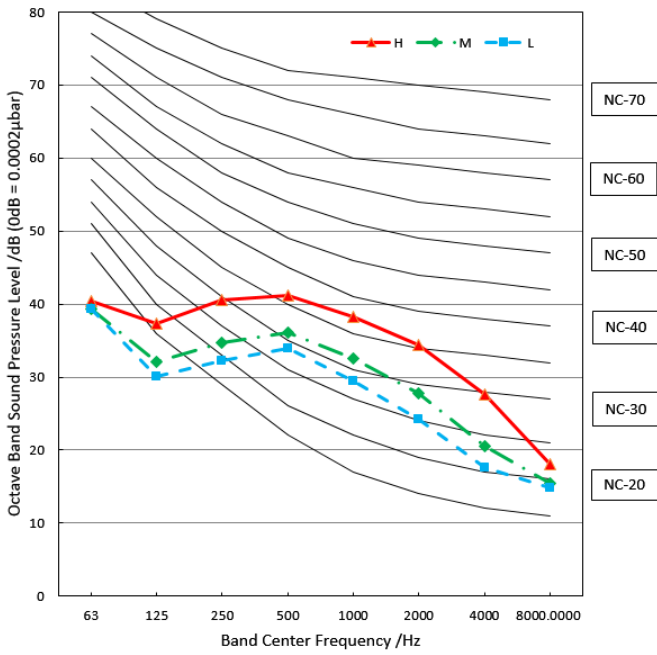

MSAG11D-18HRFN1-MT8W

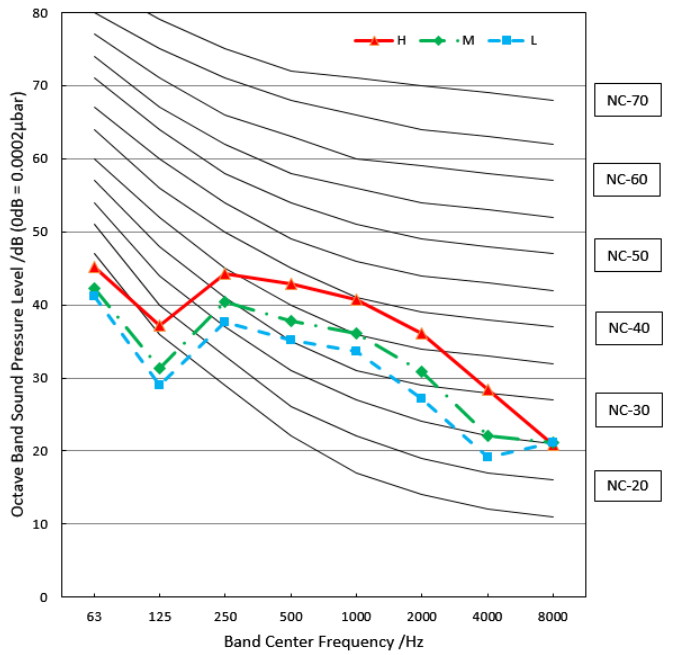

MSAG11D-23HRFN1-MU0W

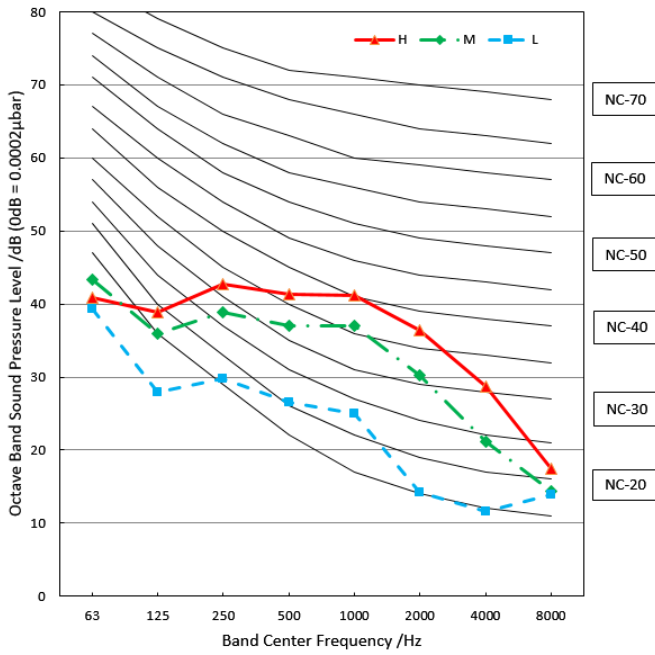

MSAGF-30HRFN1-MT0W

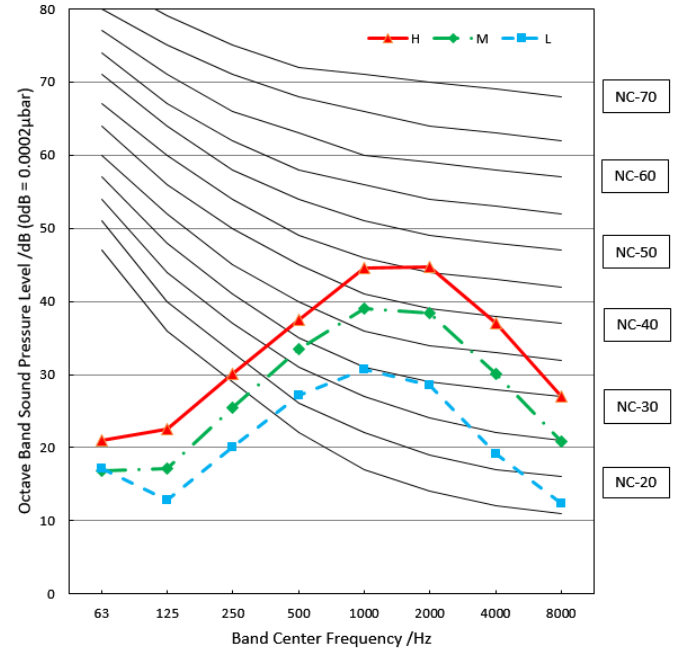

MSAGF-36HRFNX-MR0W

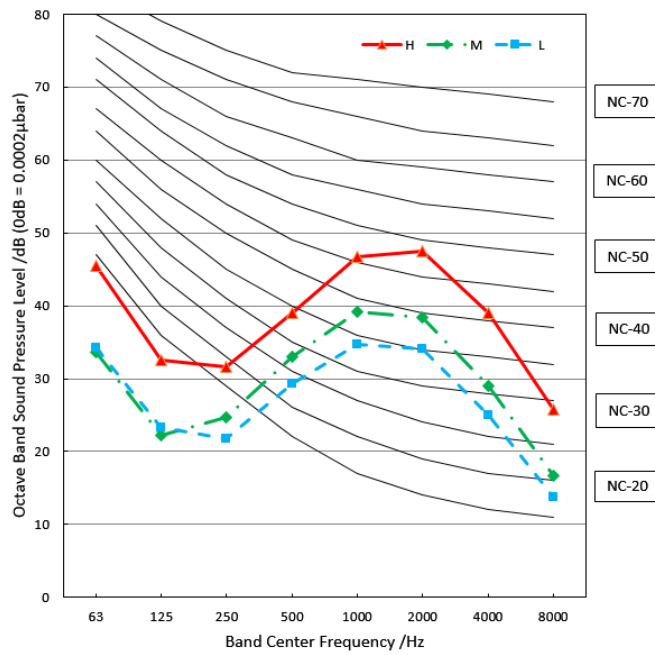

MSEPb-06HRFN1-MY5W

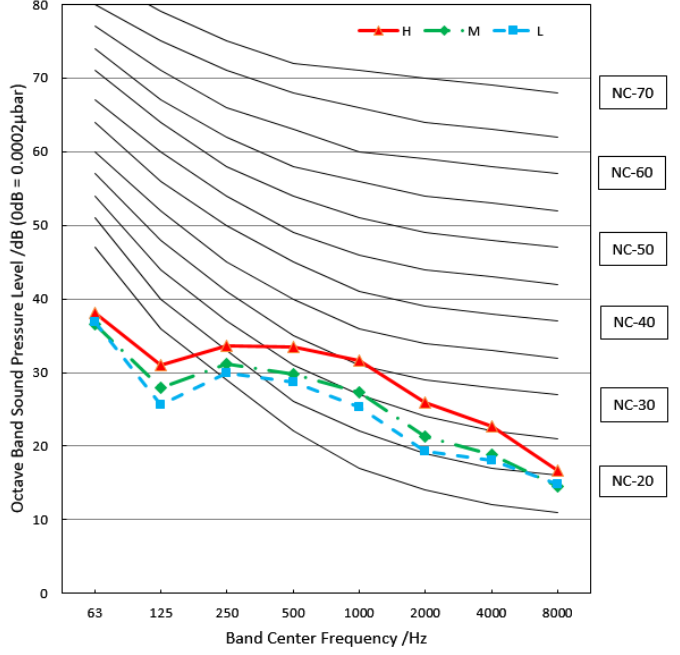

MSEPB-09HRFN1-MY5W(GA)

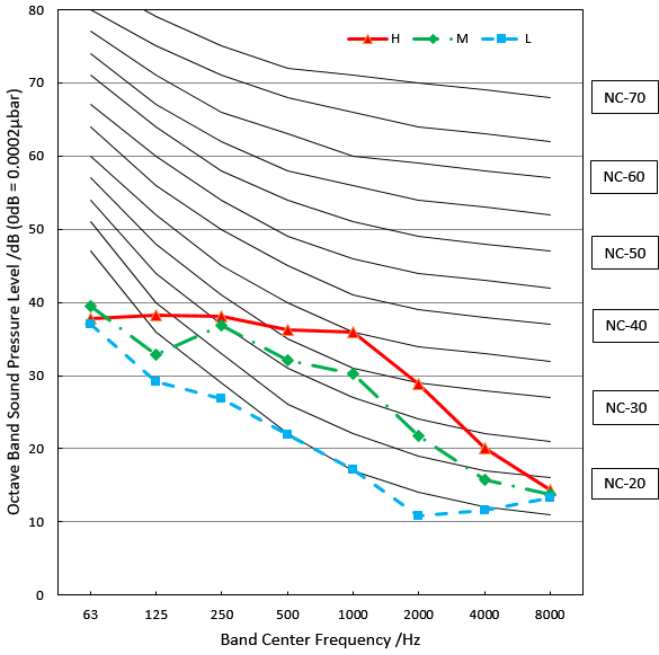

MSEPB-12HRFN1-MW5W(GA)

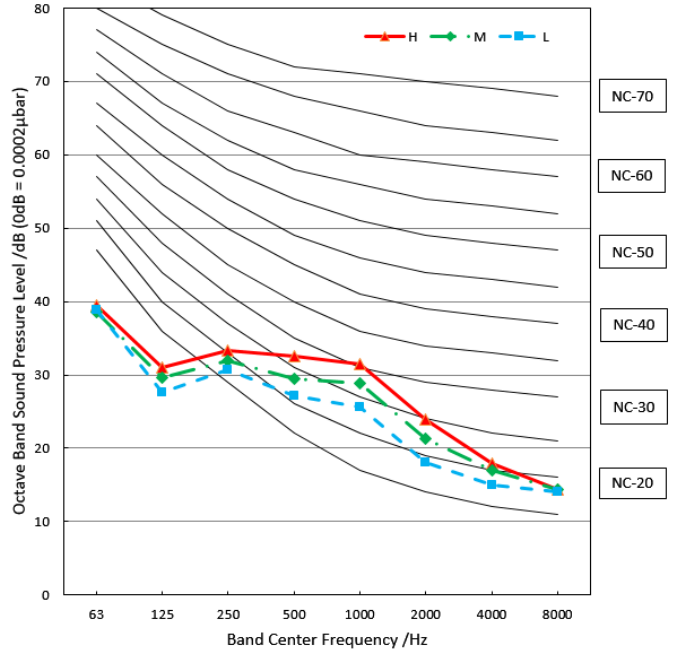

MSEPC-18HRFN1-MU0W

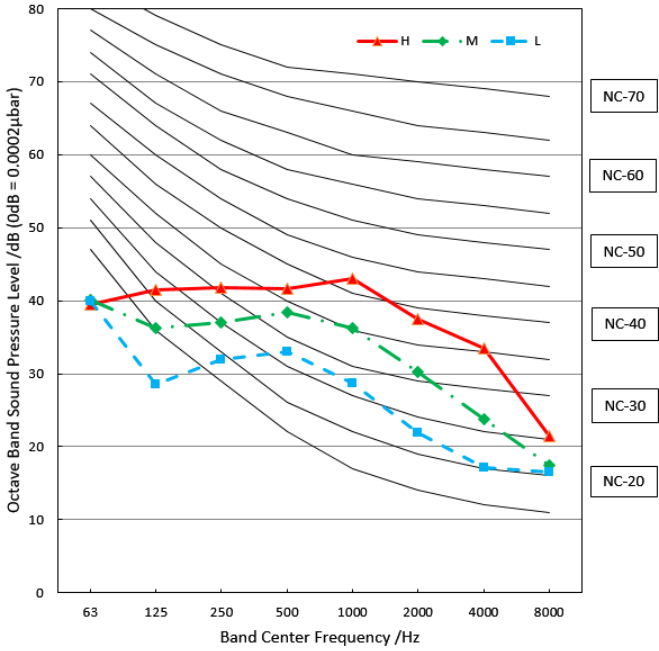

MSEPD-24HRFN1-MU0W

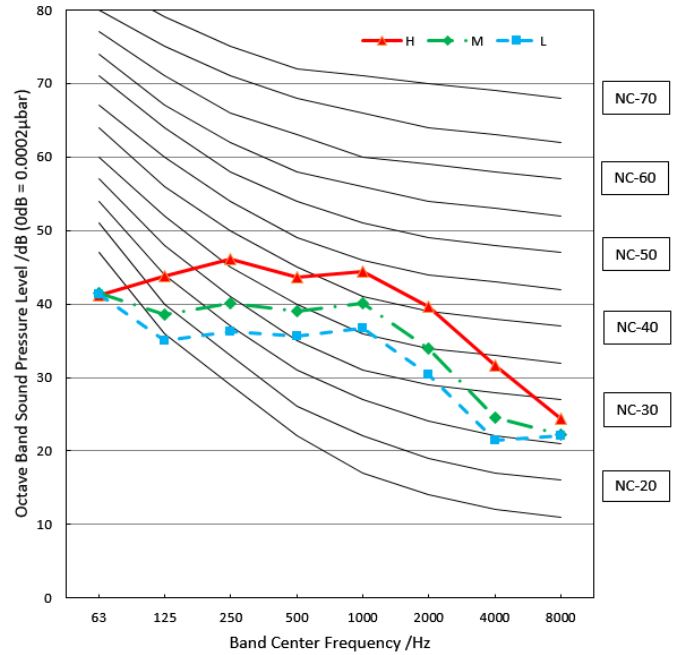

MSEPD-30HRFN1-MS8W

MSEPD-36HRFN1-MQ0W

Specifications

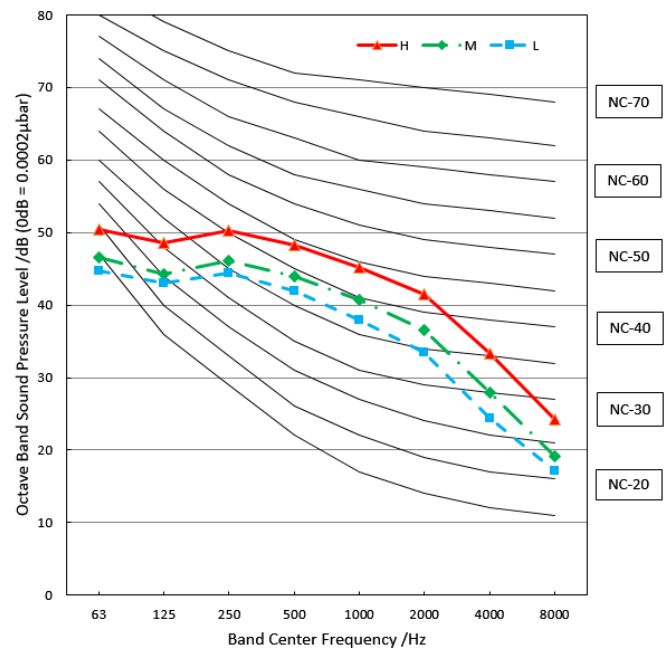
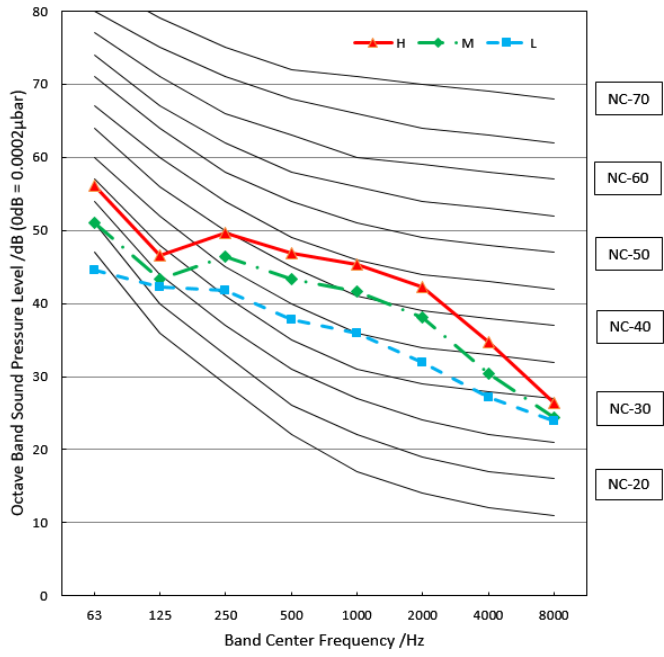

13.2 Outdoor Unit

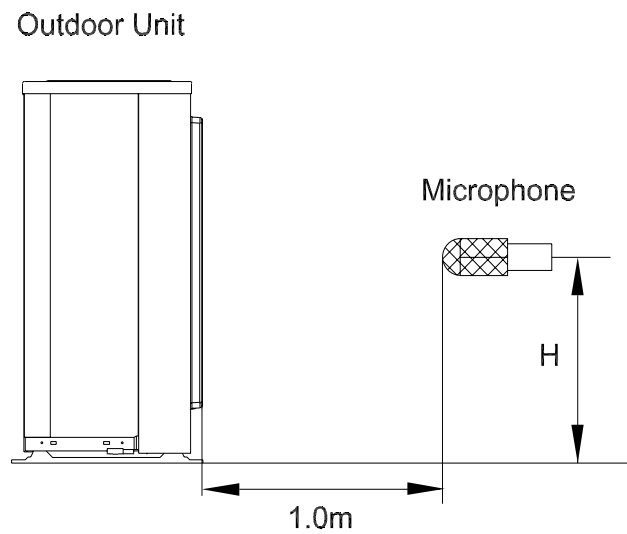

Note: $H = 0.5 \times$ height of outdoor unit

Notes:

- Sound measured at 1.0m away from the center of the unit.
- Data is valid at free field condition
- Data is valid at nominal operation condition
- Reference acoustic pressure $OdB=20\mu Pa$
- Sound level will vary depending on arrangement of factors such as the construction (acoustic absorption coefficient) of particular room in which the equipment is installed.
- The operating conditions are assumed to be standard.

M2OA-18HFN1-M

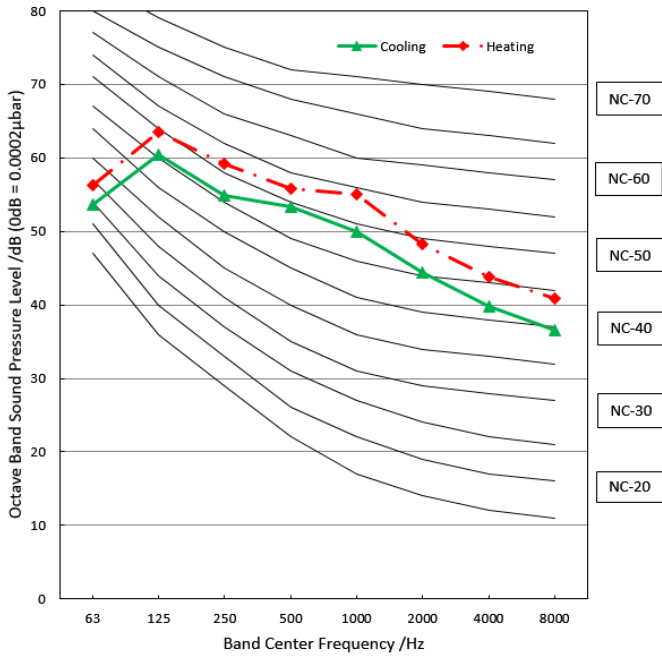

M3OJ-27HFN1-M

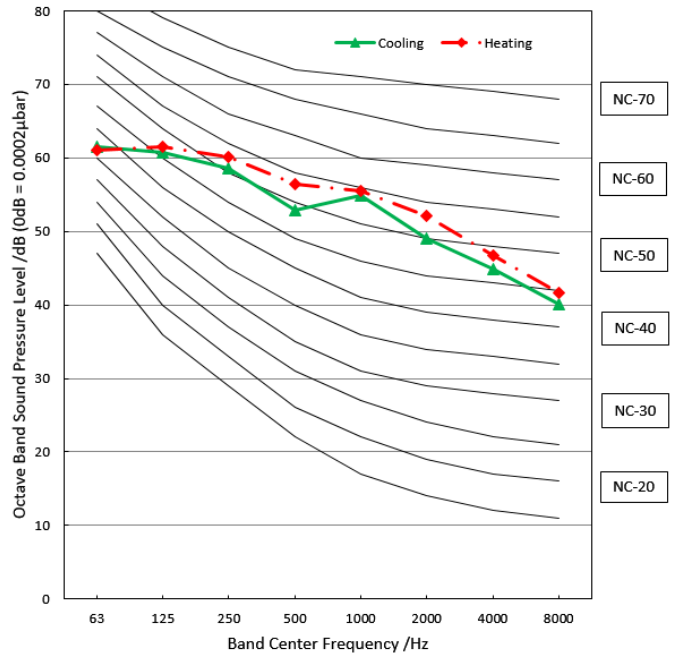

M4OG-36HFN1-M

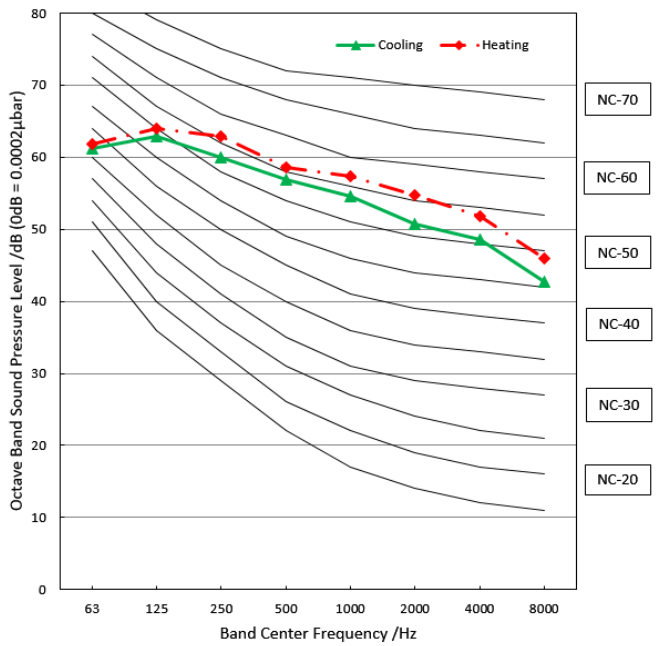

M5OG-48HFN1-M

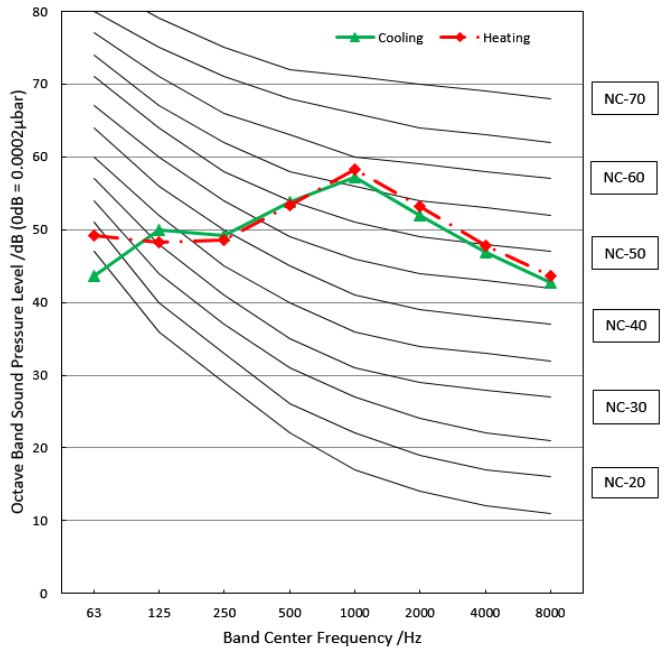

14. Electrical Characteristics

Model	Indoor Unit				Power Supply		IFM	
	Phase	Hz	Voltage	Voltage Range	MCA	MFA	kW	FLA
MTIU-09HWFN1-M	1	60	208	Min:187 Max:229	1.3	15	0.055	1.11
MTIU-12HWFN1-M					1.3	15	0.055	1.11
MTIU-18HWFN1-M					3	15	0.16	1.2
MTIU-24HWFN1-M					3	15	0.16	1.5
MCA3U-09HRFN1-M(C)					1.2	15	0.046	0.9
MCA3U-12HRFN1-M(C)					1.3	15	0.046	1
MCA3U-18HRFN1-M(C)					1.9	15	0.046	1.5
MCD1-24HRFN1-MTOW(GA)					2.5	15	0.045	1
MUEU-18HRFN1-M(C)			1.9	15	0.09	1.5		
MUEU-24HRFN1-M(C)			2.5	15	0.09	2		
MVC-18HWFN1-MW(GA)			2.5	15	0.25	2		
MVC-23HWFN1-M			4	15	0.25	3		
MVC-30HWFN1-M(GA)			4.5	15	0.75	3.5		
MVCU-36HWFN1-M(GA)			5	15	0.75	4		
MSABB-09HRFN1-MX0W			3	15	0.02	0.1		
MSABB-12HRFN1-MV0W			3	15	0.02	0.1		
MSABE-18HRFN1-MW5W			3	15	0.058	0.25		
MSABE-24HRFN1-MU0W			3	15	0.058	0.4		
MSABF-30HRFN1-MR0W			3	15	0.058	0.5		
MSABF-36HRFNX-MQ0W			3	15	0.058	0.5		
MSAG11A-06HRFN1-MU0W			3	15	0.013	0.25		
MSAG11B-09HRFN1-MX7W(GA)			3	15	0.013	0.15		
MSAG11B-12HRFN1-MV0W(GA)			3	15	0.013	0.38		
MSAG11D-18HRFN1-MT8W			3	15	0.058	0.25		
MSAG11D-23HRFN1-MU0W			3	15	0.058	0.38		
MSAGF-30HRFN1-MTOW			3	15	0.058	0.5		
MSAGF-36HRFNX-MR0W			3	15	0.058	0.5		
MSEP B-06HRFN1-MY5W			3	15	0.02	0.41		
MSEP B-09HRFN1-MY5W(GA)			3	15	0.02	0.25		
MSEP B-12HRFN1-MW5W(GA)			3	15	0.02	0.25		
MSEPC-18HRFN1-MU0W			3	15	0.03	0.4		
MSEPD-24HRFN1-MU0W			3	15	0.058	0.5		
MSEPD-30HRFN1-MS8W			3	15	0.058	0.5		
MSEPD-36HRFN1-MQ0W	3	15	0.058	0.5				

Model	Outdoor Unit				Power Supply		Compressor		OFM		
	Phase	Hz	Voltage	Voltage Range	MCA	MFA	MSC	RLA	Qty	kW	FLA
M2OA-18HFN1-M	1	60	208	Min:187	18	25	/	11	1	0.08	1
M3OJ-27HFN1-M				Max:229	24.5	30	/	14	1	0.12	1.7
M4OG-36HFN1-M			230	Min:207	25.0	40	/	18.0	1	0.12	1.0
M5OG-48HFN1-M				Max:253	40	60	/	24	2	0.085	2.5

Notes:

MCA: Minimum Circuit Amperes (A)

MFA: Maximum Fuse Amperes (A)

MSC: Maximum Starting Current

RLA: Rated Load Amperes (A)

IFM: Indoor Fan Motor

OFM: Outdoor Fan Motor

FLA: Full Load Amperes (A)

15. Static Pressure

9K

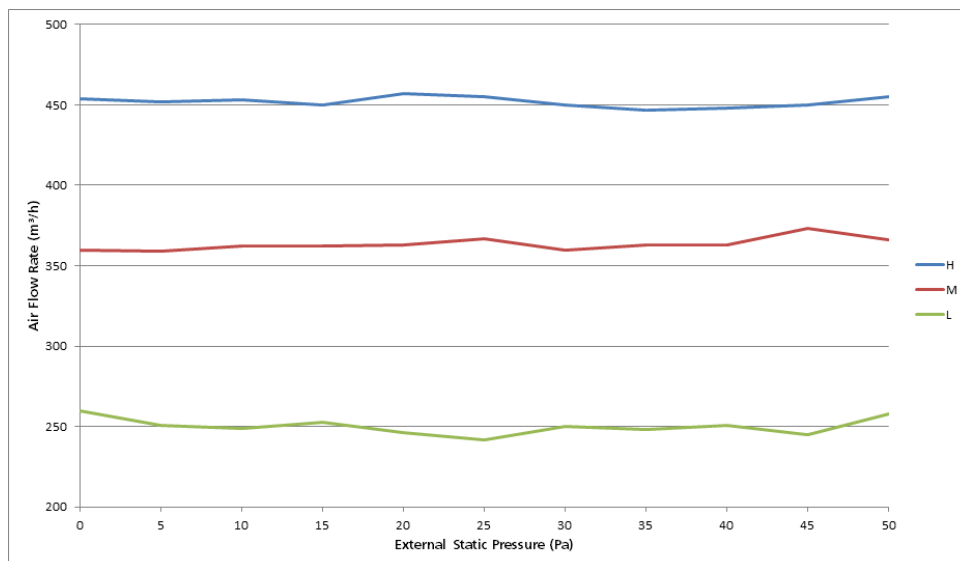
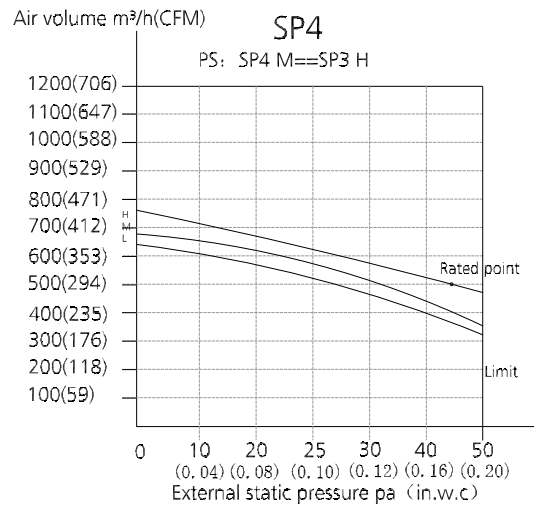
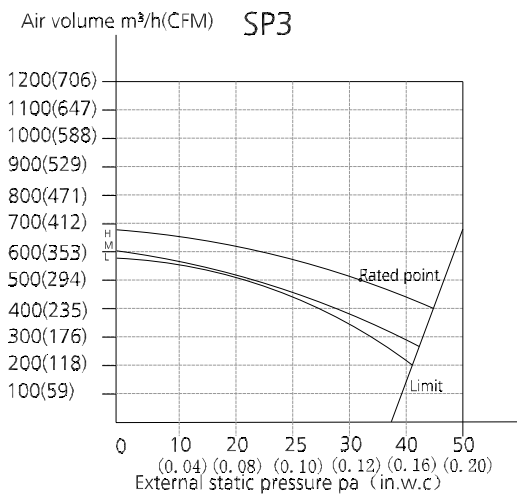
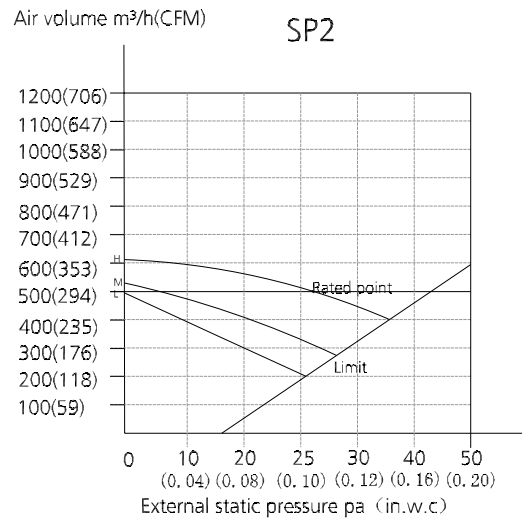
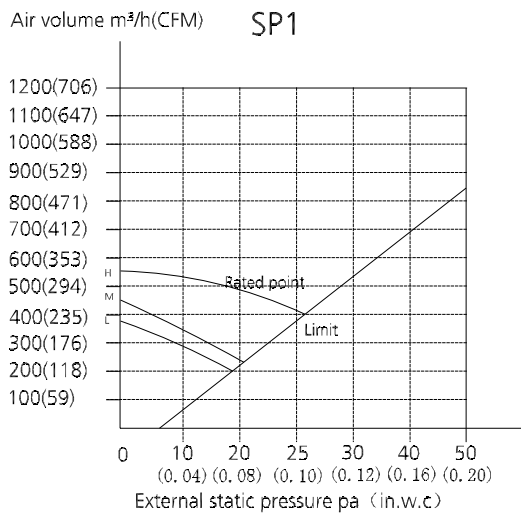

12K

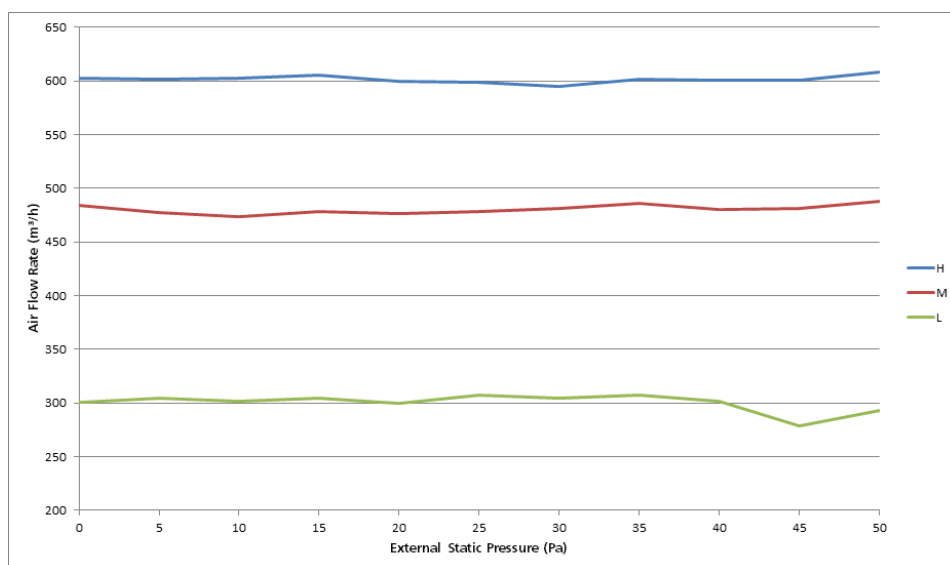
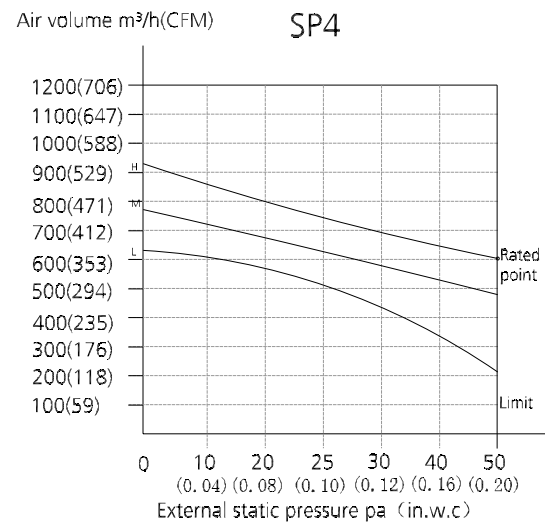
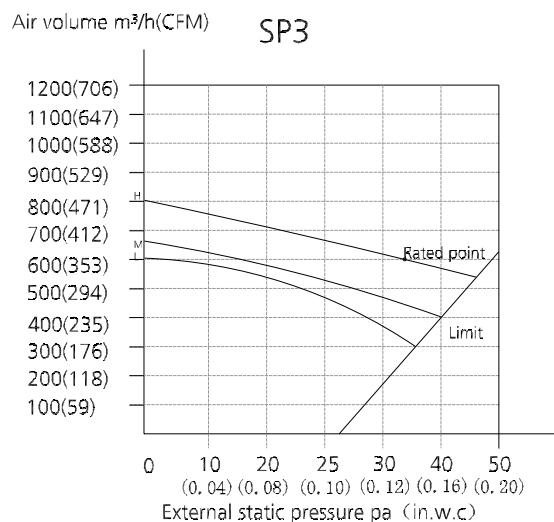
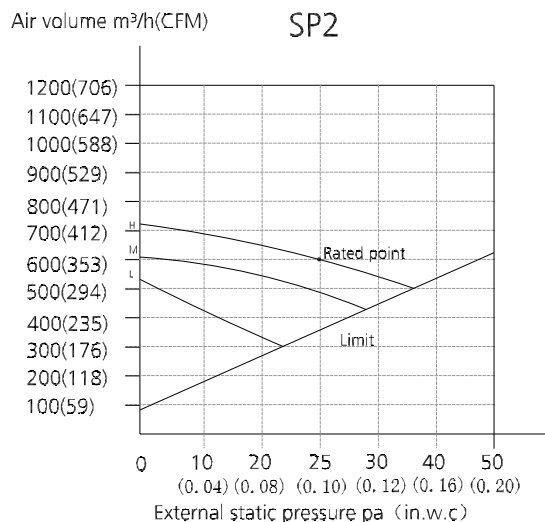
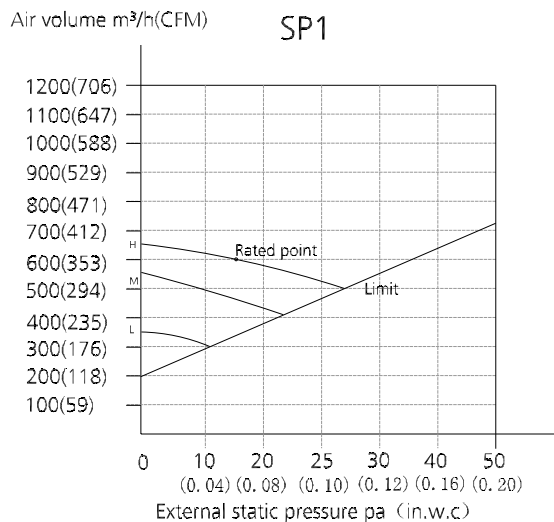

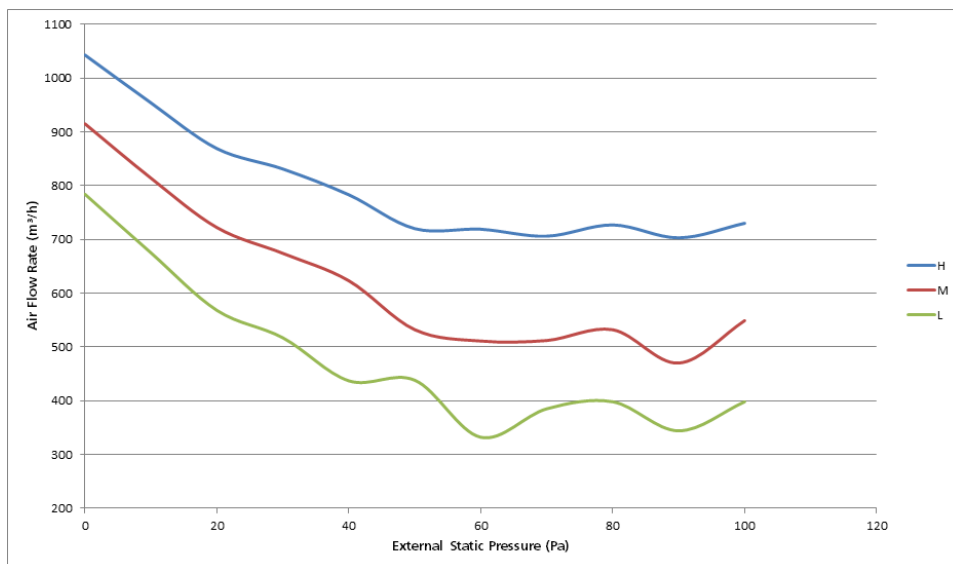
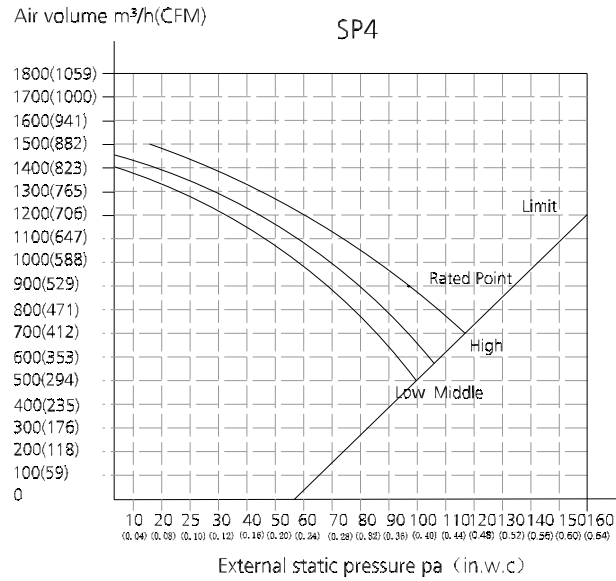
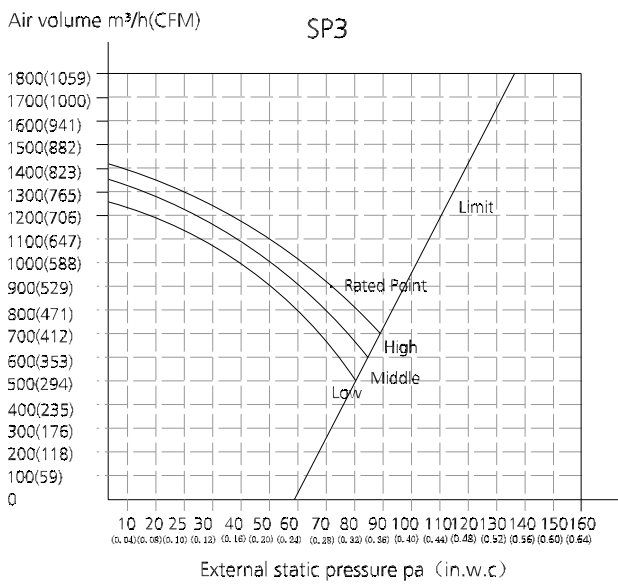
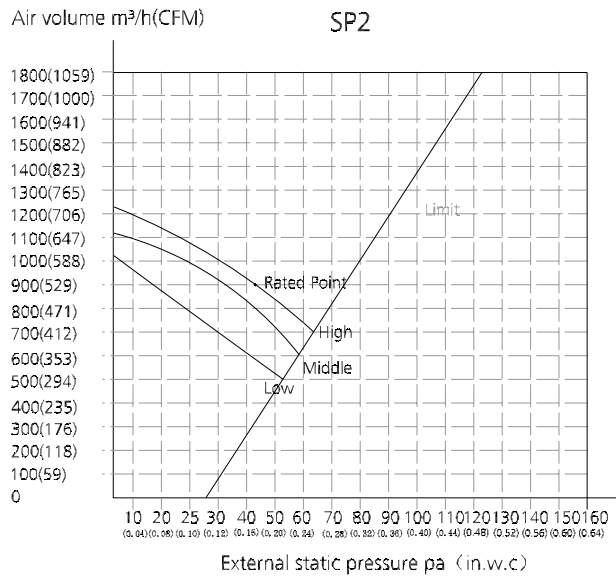
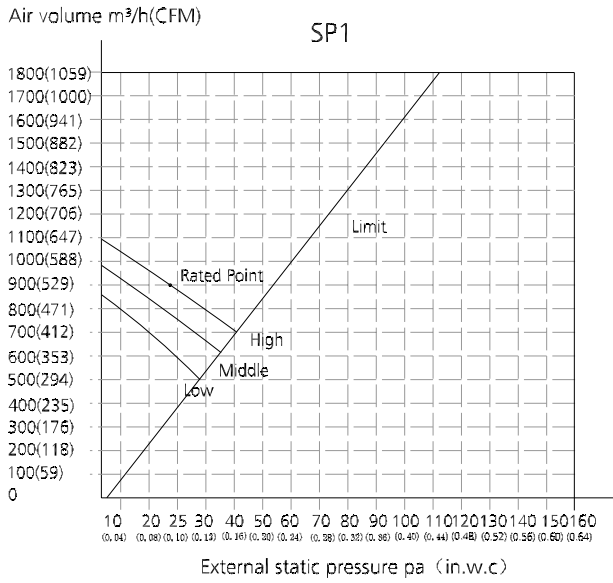

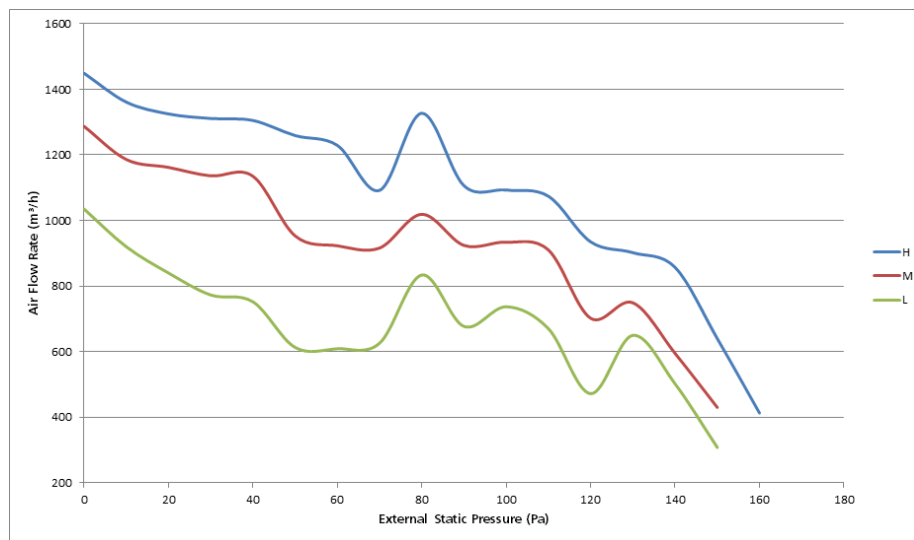
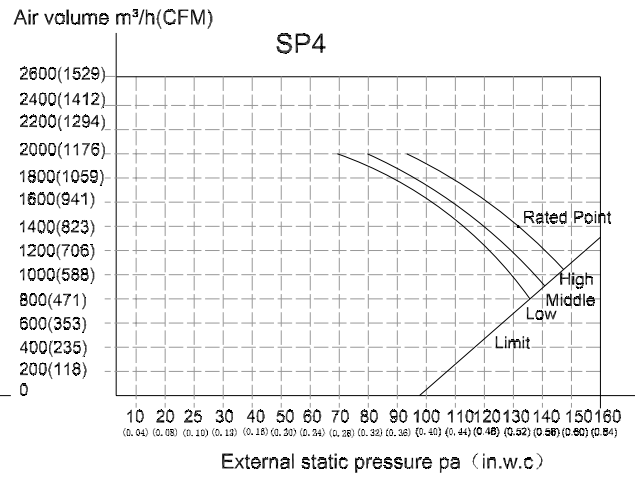
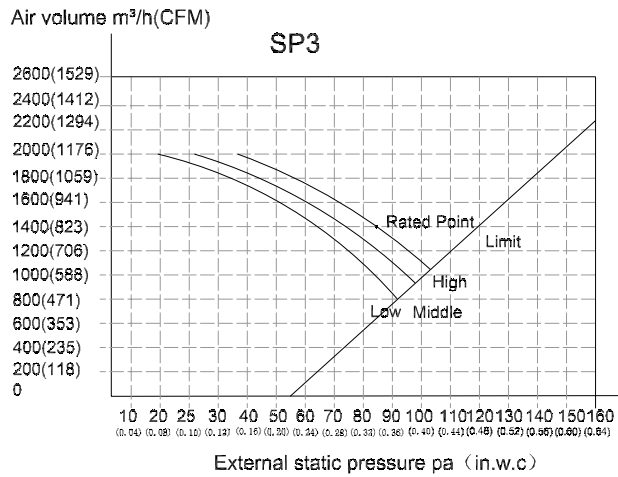
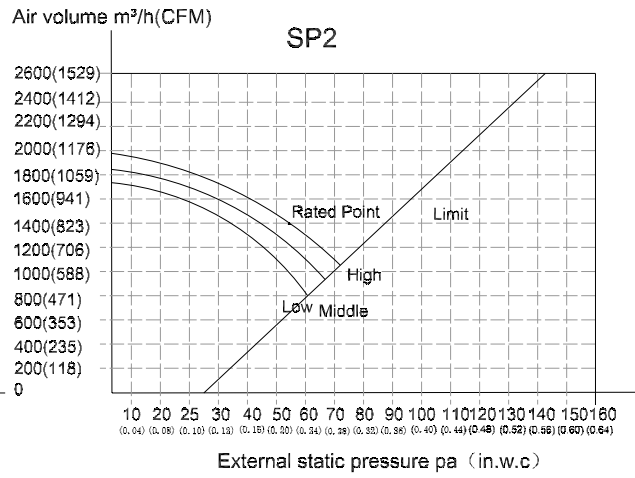
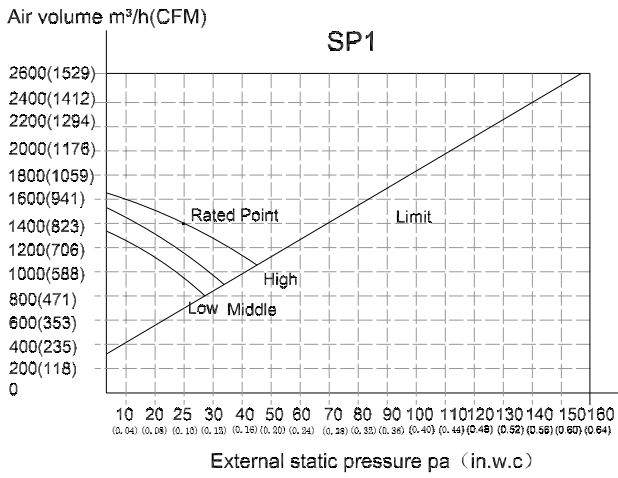

Product Features

Contents

1.	Display Function	148
2.	Operation Modes and Functions	153
2.1	Abbreviations	153
2.2	Safety Features	153
2.3	Fan.....	154
2.4	Cooling Mode	154
2.5	Heating Mode (Heat pump models).....	154
2.6	Auto Mode.....	154
2.7	Drying Mode	155
2.8	Timer Function	155
2.9	Sleep Function.....	155
2.10	Forced Operation Function	155
2.11	Auto-Restart.....	156
2.12	Follow Me	156
2.13	Drain Pump Control.....	156
2.14	Mode Conflict	156
3.	Remote Controller Functions	157
3.1	Infrared Wireless Remote Controller.....	157
3.2	LCD Wired Remote Controller	161
3.3	Centralized Controller	172
3.4	Using the wire controller to set external static pressure	173
3.5	Using the wire controller to set airflow rate	173

1. Display Function

Wall mounted type- Aurora

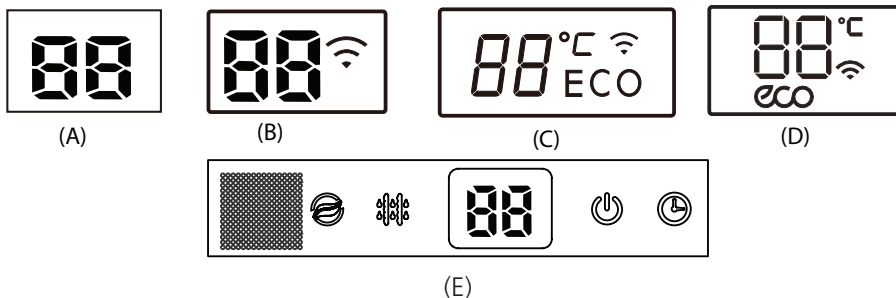

Product Features

Display		Function
		Fresh(available on select units only)
		Defrost
		When the unit is on
		When TIMER is on
ECO		ECO function (available on select units only)
°C		Lights up in different colour according to the operation mode(some units): Under COOL and DRY mode, it displays as cool colour.Under HEAT mode, it displays as warm colour.
		when Wireless Control feature is activated(some units)
	Temperature value	Temperature
	ON (3s)	Activation of Timer ON, Fresh, Swing, Turbo, or Silent
	OF (3s)	Cancellation of Timer OFF, Fresh, Swing, Turbo, or Silent
	dF	Defrost
	cF	Warming in heating mode
	SC	Self-clean (available on select units only)
	FP	Heating in room temperature under 8°C

Note: Please select the display function according to your purchase product.





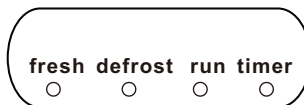

Wall mounted type- Infini



Display A



Display B

Display		Function
fresh		Fresh(available on select units only)
defrost		Defrost
run		When the unit is on
timer		When TIMER is on
		WiFi control (available on select units only)
	Temperature value	Temperature
	 (3s)	Activation of Timer ON, Fresh, Swing, Turbo, or Silent
	 (3s)	Cancellation of Timer OFF, Fresh, Swing, Turbo, or Silent
		Defrost
		Active Clean
		Heating in room temperature under 8°C

Note: Please select the display function according to your purchase product.

Wall mounted type-All Easy PRO









(A)



(B)



(C)

Display		Function
ECO		ECO function (available on select units only)
		when Wireless Control feature is activated(some units)
     	Temperature value	Temperature
		Timer ON is set.
		Activation of , Fresh, Swing, Turbo, ECO, Breeze away, ECO intelligent or Silence
		Timer OFF is set.
		Cancellation of Fresh, Swing, Turbo, ECO, Breeze away, ECO intelligent or Silent
		Defrost
	Active Clean	
	Heating in room temperature under 8°C	

Note: Please select the display function according to your purchase product.

A6 Duct type:

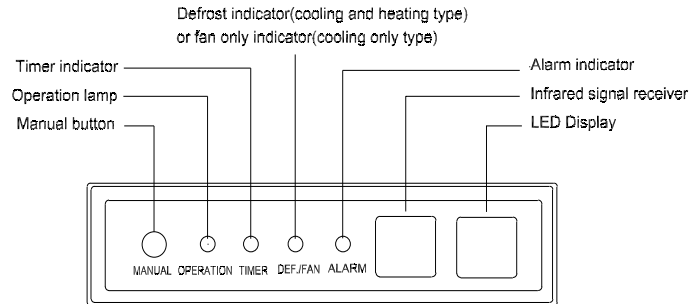

Compact Cassette type:

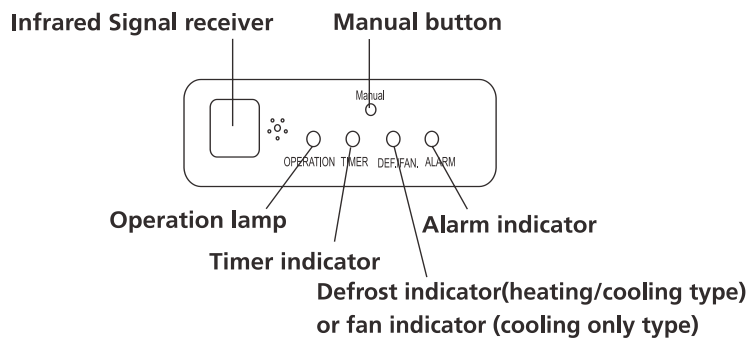

New 4-way Cassette type

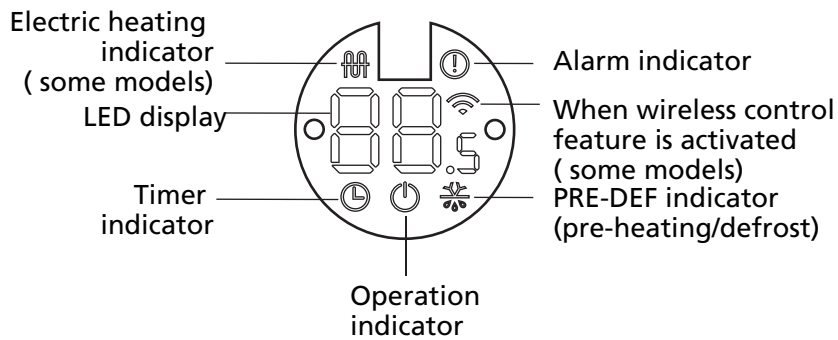

Floor Ceiling Type

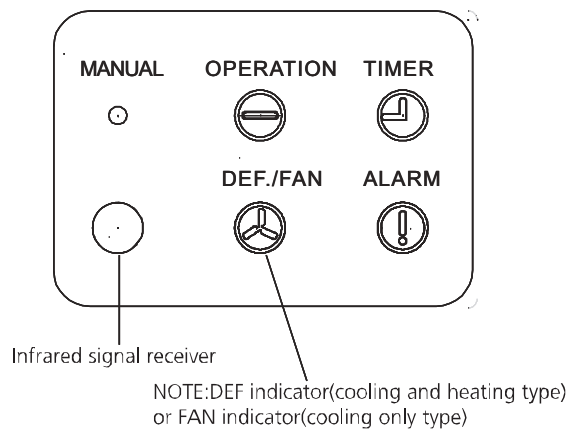

Air Handler type

Mode	Priority	G	Y1	Y/Y2	B	W	W1	W2	E/AUX	DH/DS/BK	Display
Shut down	/	0	0	0	0	0	0	0	0	*	00
Fan	7	1	0	0	0	0	0	0	0	1	01
Fan		1	0	0	0	0	0	0	0	0	
Cooling	6	*	1	0	0	0	0	0	0	1	02
Cooling 2		*	*	1	0	0	0	0	0	1	03
Dehumidification 1		*	1	0	0	0	0	0	0	0	04
Dehumidification 2		*	*	1	0	0	0	0	0	0	05
Heating 1	5	*	1	0	1	0	0	0	0	1	06
Heating 2		*	*	1	1	0	0	0	0	1	
Heating 2		*	*	*	*	1	0	0	0	1	07
Electric heating 1	3	*	0	0	0	0	1	0	0	*	08
Electric heating 1		*	0	0	0	0	0	1	0	*	
Electric heating 2		*	0	0	0	0	0	1	1	0	*
Heating 1+Electric heating 1	4	*	1	0	1	0	1	0	0	1	10
Heating 1+Electric heating 1		*	1	0	1	0	0	1	0	1	
Heating 2 +Electric heating 1		*	*	1	1	0	1	0	0	1	
Heating 2 +Electric heating 1		*	*	*	*	1	1	0	0	1	
Heating 2 +Electric heating 1		*	*	1	1	0	0	1	0	1	
Heating 2 +Electric heating 1		*	*	*	*	1	0	1	0	1	
Heating 1+Electric heating 2	4	*	1	0	1	0	1	1	0	1	11
Heating 2+Electric heating 2		*	*	1	1	0	1	1	0	1	
Heating 2+Electric heating 2		*	*	*	*	1	1	1	0	1	
Emergency heating	1	*	*	*	*	*	*	*	1	*	12
Heating zone control	2	*	1	0	1	0	*	*	0	0	13
Heating zone control		*	*	1	1	0	*	*	0	0	
Heating zone control		*	*	*	*	1	*	*	0	0	

NOTICE:

1 : signal

0 : no signal

If the input does not meet the above, press shutdown for processing.

2. Operation Modes and Functions

2.1 Abbreviation

Unit element abbreviations

Abbreviation	Element
T1	Indoor room temperature
T2	Coil temperature of evaporator middle
T2B	Coil temperature of evaporator outlet(It is located in outdoor unit)
T3	Coil temperature of condenser
T4	Outdoor ambient temperature
T5	Compressor discharge temperature
TS	Setting temperature
Tsc	Adjusted setting temperature
TCDE1	Exit defrost temperature1
TCDE2	Exit defrost temperature2 (maintain for a period of time)

In this manual, such as TCDE1, TCDE2...etc., they are well-setting parameter of EEPROM.

2.2 Safety Features

Open Circuit/Disconnection Sensor Protection

Automatic shutoff based on fan speed

For A6 Duct type,

If a fault occurs on the air volume regulator or the regulator enters protection mode, it sends the error message CF and an instruction to reduce fan speed to the master. The message and the instruction can be inquired with the remote controller or the wired controller. (Fault and protection information are displayed for one minute). After a fault occurs, the master unit shows the error code E3 and the fault count for one minute.

If the fault occurs three times, then the fan is unable to resolve the problem independently. External shutdown by a remote controller, wired controller, or central controller must be used to clear the fan fault and fault count. The fan runs normally for 5 minutes while clearing fault count.

For other types,

If the indoor fan speed registers below 300RPM for an extended period of time, it shuts off and restarts in 30 seconds. If this happens 3 times, the unit ceases operation and the corresponding error code is displayed on the

indoor unit.

If outdoor fan speed registers below 100RPM or higher than 2400RPM for an extended period of time, the unit ceases operation and the corresponding error code is displayed on the indoor unit and outdoor unit.

Indoor fan delayed operation

- When the unit starts, the louver is automatically activated and the indoor fan will operate after a period of 7 seconds.
- If the unit is in heating mode, the indoor fan is regulated by the anti-cold wind function.

Compressor three-minute delay at restart

Compressor functions are delayed for up to one minute upon the first startup of the unit, and are delayed for up to three minutes upon subsequent unit restarts.

Inverter module protection

The inverter module has an automatic shutoff mechanism based on the unit's current, voltage, and temperature. If automatic shutoff is initiated, the corresponding error code is displayed on the indoor unit and the unit ceases operation.

Automatic shutoff based on discharge temperature

If the compressor discharge temperature exceeds a certain level for a period of time, the compressor ceases operation.

Oil return

Running rules:

1. If the compressor frequency keeps lower than setting frequency for setting time, the AC will rise the frequency to setting frequency for setting time and then resume to former frequency.
2. The EXV will keep 300p while the indoor units will keep the current running mode.

If the outdoor ambient is higher than setting frequency during the oil return, the AC quit oil return.

2.3 Fan Mode

When fan mode is activated:

- The outdoor fan and compressor cease operation.
- Temperature control is disabled and no temperature setting is displayed.
- The indoor fan speed can be set to high, medium, low, or auto or 1%-100%.
- The louver operations are identical to those in cooling mode.

2.4 Cooling Mode

2.4.1 Indoor Fan Control

- In cooling mode, the indoor fan operates continuously. The fan speed can be set to high, medium, low, auto or 1%-100%.
- The auto fan acts according to the value of T1-Ts.

For Wall mounted type-All Easy Pro, Infini, New 4-way cassette type& Air handler type, the auto fan acts according to the value of T1-Tsc.

2.4.2 Outdoor Fan Control

- The outdoor fan is controlled by T4.

2.4.3 Evaporator Temperature Protection

When $T_2 < 4^\circ\text{C}$ for 250 seconds or $T_2 < 0^\circ\text{C}$, the compressor and outdoor fan cease operation and resume to normal when $T_2 > 8^\circ\text{C}$ and the time of protection is no less than 3 minutes.

2.4.4 Condenser Temperature Protection

When condenser temperature is more than setting value, the compressor ceases operations.

2.5 Heating Mode(Heat pump models)

2.5.1 Indoor Fan Control:

- When the compressor is on, the fan speed can be set to high, medium, low, auto or 1%-100%.. And the anti-cold wind function has the priority.
- The auto fan acts according to the value of T1-Ts.

For Wall mounted type-All Easy Pro, Infini, New 4-way cassette type& Air handler type, the auto fan acts according to the value of T1-Tsc.

2.5.2 Outdoor Fan Control:

- The outdoor fan is controlled by T4.

2.5.3 Defrosting mode

- The unit enters defrosting mode according to the

value of temperature of T3 and the value range of temperature change of T3 and also the compressor running time.

- If any one of the following items is satisfied, the defrosting will finish and the machine will turn to normal heating mode.
 - T3 rises to be higher than $TCDE1^\circ\text{C}$.
 - T3 keeps to be higher than $TCDE2^\circ\text{C}$ for 80 seconds.
 - The machine has run for 10 minutes in defrosting mode.
- If any one of the following conditions is satisfied, the unit enters defrosting mode
 - If T3 or T4 is lower than $-3^\circ\text{C}(26.6^\circ\text{F})$ for 30 seconds, $T_s - T_1$ is lower than $5^\circ\text{C}(9^\circ\text{F})$ and compressor running time is more than 90min.
 - If T3 or T4 is lower than $-3^\circ\text{C}(26.6^\circ\text{F})$ for 30 seconds and compressor running time is more than 120min.
- If any one of the following conditions is satisfied, defrosting ends and the machine switches to normal heating mode:
 - T3 rises above $TCDE1+4^\circ\text{C}$.
 - T3 maintained above $TCDE2+4^\circ\text{C}$ for 80 seconds.
 - Unit runs for 15 minutes consecutively in defrosting mode.

2.5.4 Evaporator Temperature Protection

When the evaporator temperature exceeds a preset protection value, the compressor and outdoor fan cease operations, the outdoor fan motor ceases operation 30 seconds later.

2.5.5 Prevent Over-Heating

In heating mode, when the indoor unit has no capacity requirement due to indoor room temperature increased, the Indoor fan will run in super breeze. (Anti-cold wind function has the priority)

2.6 Auto Mode

For Wall mounted type-All Easy Pro, Infini & New 4-way cassette type:

- This mode can be selected with the remote controller and the temperature setting can be adjusted between $16^\circ\text{C} \sim 30^\circ\text{C}$
- In auto mode, the machine selects cooling, heating or fan-only mode on the basis of T1, Ts and T4.

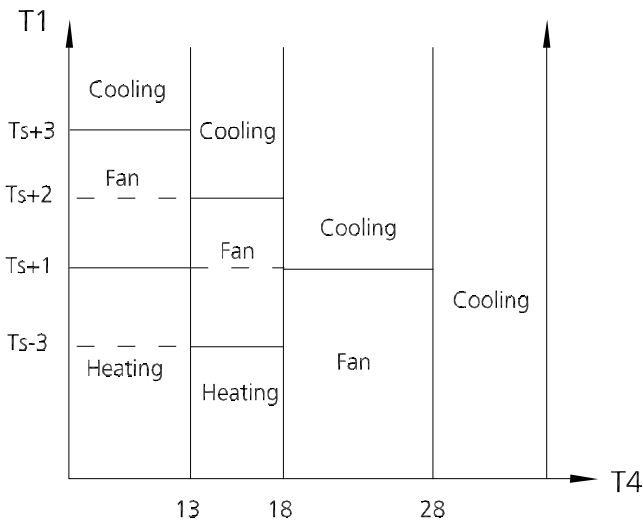

- This mode can be selected with the remote controller and the temperature setting can be adjusted between 17°C~30°C
- In auto mode, the machine selects cooling, heating, or fan-only mode on the basis of ΔT ($\Delta T = T1 - Ts$).

For Air handler type:

ΔT	Running mode
$\Delta T > 2^{\circ}\text{C}$ (3.6°F)	Cooling
-3°C (-5.4°F) $\leq \Delta T \leq 2^{\circ}\text{C}$ (3.6°F)	Fan-only
$\Delta T < -3^{\circ}\text{C}$ (-5.4°F)	Heating*

For other models:

ΔT	Running mode
$\Delta T > 2^{\circ}\text{C}$ (3.6°F)	Cooling
-2°C (-3.6°F) $\leq \Delta T \leq 2^{\circ}\text{C}$ (3.6°F)	Fan-only
$\Delta T < -2^{\circ}\text{C}$ (-3.6°F)	Heating*

Heating*: In auto mode, cooling only models run the fan.

- Indoor fans run at the auto fan speed of the relevant mode.
- The louver operates the same as in relevant mode.
- If the machine switches mode between heating and cooling, the compressor pauses for a certain period of time intermittently and then selects a mode based on T1-Ts.
- If the setting temperature is modified, the machine selects a new running function.

2.7 Drying Mode

- Indoor fan speed is fixed at low and cannot be changed.
- Low indoor room temperature protection

- In drying mode, if room temperature is lower than 10°C, the indoor fan will stop and not resume until room temperature exceeds 12°C.
- All protections are activated and operate the same as they do in cooling mode.
- The louver operates the same as in cooling mode.

2.8 Timer Function

- The timing range is 24 hours.
- Timer On. The machine turns on automatically at the preset time.
- Timer Off. The machine turns off automatically at the preset time.
- Timer On/Off. The machine turns on automatically at the preset On Time, and then turns off automatically at the preset Off Time.
- Timer Off/On. The machine turns on automatically at the preset Off Time and then turns off automatically at the preset On Time.
- The timer does not change the unit operation mode. If the unit is off now, it does not start up immediately after the "timer off" function is set. When the setting time is reached, the timer LED switches off and the unit running mode remains unchanged.
- The timer uses relative time, not clock time

2.9 Sleep Function

- The sleep function is available in cooling, heating, or auto mode.
- The operational process for sleep mode is as follows:
 - When cooling, the temperature rises 1°C (to not higher than 30°C) every hour. After 2 hours, the temperature stops rising and the indoor fan is fixed to auto speed.
 - When heating, the temperature decreases 1°C (to not lower than 17°C or 16°C (For Wall mounted type-All Easy Pro, Infini, New 4-way cassette type & Air handler type) every hour. After 2 hours, the temperature stops decreasing and the indoor fan is fixed to auto speed. Anti-cold wind function takes priority.

2.10 Forced operation function

- Forced cooling mode:

The compressor and outdoor fan continue to run and the indoor fan runs at rated speed. After running for 30 minutes, the AC will switch to auto mode with a preset temperature of 24°C

- Forced auto mode:

Forced auto mode operates the same as normal auto mode with a preset temperature of 24°C.

- When any one of indoor units runs in forced cooling, it is designated as the master forced cooling unit. Other indoor units act as the slave forced cooling units. The slave forced cooling units cannot exit forced cooling mode until the master forced cooling unit does so. They then switch to cooling mode in low fan with the temperature set at 24°C.
- Forced defrosting mode:
 - In the forced cooling mode (single heat engine for forced auto mode), press and hold the forced key for 5 seconds after release, immediately enter the forced frosting mode.
 - When any one of indoor units runs in forced defrosting mode, the indoor fan is off and other indoor fans are off. The outdoor unit operates forced defrosting.

2.11 Auto-Restart

- The indoor unit has an auto-restart module that allows the unit to restart automatically. The module automatically stores the current settings (not including sleep mode) and, in the case of a sudden power failure, will restore those setting automatically within 3 minutes after power returns.
- If the unit was in forced cooling mode, it will run in this mode for 30 minutes and turn to auto mode with temperature set to 24°C.
- If there is a power failure while the unit is running, the compressor starts 3 minutes after the unit restarts. If the unit was already off before the power failure, the compressor starts 1 minute after the unit restarts.

2.12 2.12 Follow Me (Optional)

- If you press “Follow Me” on the remote, the indoor unit will beep. This indicates the follow me function is active.
- Once active, the remote control will send a signal every 3 minutes, with no beeps. The unit automatically sets the temperature according to the measurements from the remote control.
- The unit will only change modes if the information from the remote control makes it necessary, not from the unit’s temperature setting.

2.13 Drain Pump Control (Optional)

- Use the water-level switch to control drain pump.
- The system checks the water level every 5 seconds.
 - When the A/C operates in cooling (including auto cooling) or forced cooling mode, the pump begins running immediately and continuously until cooling stops.
 - If the water level increases up to the control point, the LED displays an alarm code and the drain pump opens and continually monitors the water level. If the water level falls and LED alarm code is no longer displayed (drain pump close delay is 1 minute), the unit goes back into its last mode. Otherwise, the entire system (including the pump) stops and the LED displays an alarm again after 3 minutes.

2.14 Mode Conflict

- The indoor units can not work cooling mode and heating at same time.
- Heating mode has a priority.

(1) Definition

	Cooling mode	Heating Mode	Fan	Off
Cooling mode	No	Yes	No	No
Heating Mode	Yes	No	Yes	No
Fan	No	Yes	No	No
Off	No	No	No	No

No: No mode conflict;

Yes: Mode conflict

(2) Unit action

- In case of one Indoor unit working in cooling mode or fan mode, and another indoor unit is set to heating mode, the indoor unit working in cooling mode or fan mode will change to off. The outdoor unit will change to heating mode after compressor stop 3 minutes. .
- In case of one Indoor unit working in heating mode, and another indoor unit is set to cooling mode or fan mode, the indoor unit setting to cooling mode or fan mode will change to stand by. The outdoor unit will continue working in heating mode.
- If heating mode stops (not including the indoor unit in heating mode reaching the set temperature), 3 minutes after the outdoor unit restarts and works in cooling mode or fan-only mode.

3. Remote Controller Functions

3.1 Infrared Wireless Remote Controller

3.1.1 RG51A(1)/EU1(Standard for wall mounted type-Aurora) RG51B(1)/EU1(Standard for compact cassette & Floor ceiling type)

Remote Controller Specifications

Model	RG51A(1)/EU1, RG51B(1)/EU1
Rated Voltage	3.0V (Dry batteries R03/LR03x2)
Reaching Distance	8m
Environment Temperature Range	-5°C ~ 60°C (23°F ~ 140°F)

Buttons and Functions

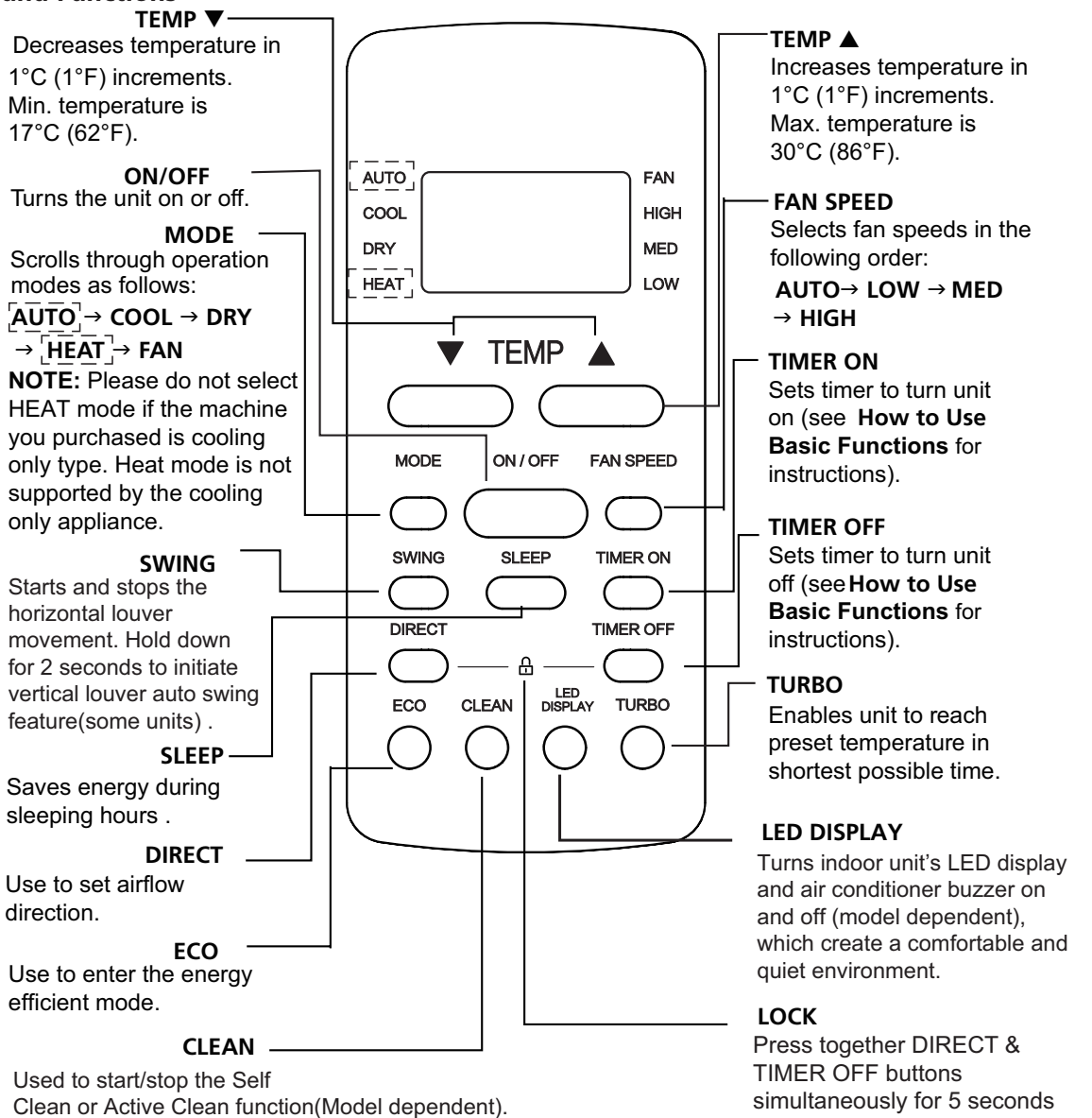

RG51A(1)/EU1

TEMP ▼
Decreases temperature in 1°C (1°F) increments. Min. temperature is 17°C (62°F).

ON/OFF
Turns the unit on or off.

MODE
Scrolls through operation modes as follows:
AUTO → COOL → DRY → [HEAT] → FAN

NOTE: Please do not select HEAT mode if the machine you purchased is cooling only type. Heat mode is not supported by the cooling only appliance.

SWING
Starts and stops the horizontal louver movement. Hold down for 2 seconds to initiate vertical louver auto swing feature(some units).

SLEEP
Saves energy during sleeping hours.

DIRECT
Use to set airflow direction.

SHORT CUT
Sets and activates your favorite pre-settings

CLEAN
Used to start/stop the Self Clean or Active Clean function(Model dependent)

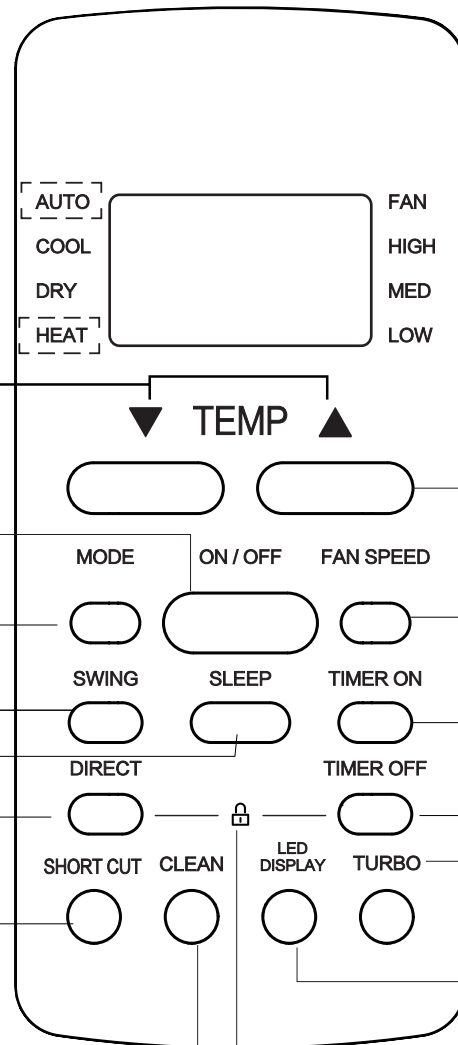

TEMP ▲
Increases temperature in 1°C (1°F) increments. Max. temperature is 30°C (86°F).

FAN SPEED
Selects fan speeds in the following order:
AUTO → LOW → MED → HIGH

TIMER ON
Sets timer to turn unit on (see How to Use Basic Functions for instructions).

TIMER OFF
Sets timer to turn unit off (see How to Use Basic Functions for instructions).

TURBO
Enables unit to reach preset temperature in shortest possible time.

LED DISPLAY
Turns indoor unit's LED display and air conditioner buzzer on and off (model dependent), which create a comfortable and quiet environment.

LOCK
Press together DIRECT & TIMER OFF buttons simultaneously for 5 seconds to lock the keyboard. Press together the two buttons for 2 seconds to unlock the keyboard.

RG51B(1)/EU1

3.1.2 RG51A(2)/EU1 (Standard for wall-mounted type-Infini)

Remote Controller Specifications

Model	RG51A(2)/EU1
Rated Voltage	3.0V (Dry batteries R03/LR03×2)
Reaching Distance	8m
Environment Temperature Range	-5 °C ~60 °C (23 °F ~140 °F)

Buttons and Functions

TEMP ▼
Decreases temperature in 1°C (1°F) increments. Min. temperature is 16°C (60°F).

ON/OFF
Turns the unit on or off.

MODE
Scrolls through operation modes as follows:
[AUTO] → COOL → DRY → [HEAT] → FAN
NOTE: Please do not select HEAT mode if the machine you purchased is cooling only type. Heat mode is not supported by the cooling only appliance.

SWING
Starts and stops the horizontal louver movement. Hold down for 2 seconds to initiate vertical louver auto swing feature (some units).

SLEEP
Saves energy during sleeping hours.

DIRECT
Use to set airflow direction.

ECO
Use to enter the energy efficient mode.

CLEAN
Used to start/stop the Self Clean or Active Clean function. (Model dependent).

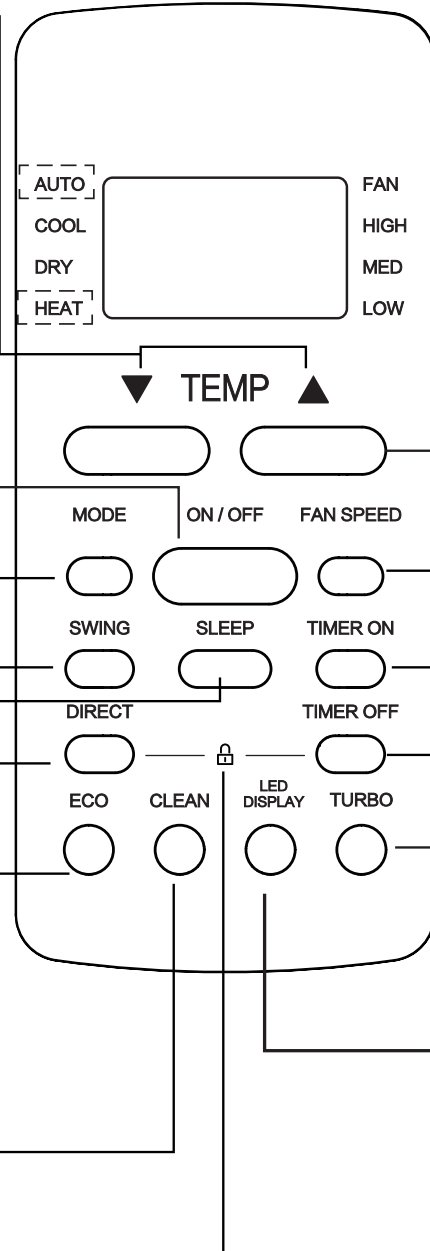

TEMP ▲
Increases temperature in 1°C (1°F) increments. Max. temperature is 30°C (86°F).
NOTE: Press together ▼ & ▲ buttons at the same time for 3 seconds will alternate the temperature display between the °C & °F.

FAN SPEED
Selects fan speeds in the following order:
AUTO → LOW → MED → HIGH

TIMER ON
Sets timer to turn unit on (see **How to Use Basic Functions** for instructions).

TIMER OFF
Sets timer to turn unit off (see **How to Use Basic Functions** for instructions).

TURBO
Enables unit to reach preset temperature in shortest possible time.

LED DISPLAY
Turns indoor unit's LED display and air conditioner buzzer on and off (model dependent), which create a comfortable and quiet environment.

LOCK
Press together DIRECT & TIMER OFF buttons simultaneously for 5 seconds to lock the keyboard. Press together the two buttons for 2 seconds to unlock the keyboard.

3.1.3 RG10A(B2S)/BGEFU1 (Standard for All Easy Pro series &MCD1-24HRFN1-MT0W(GA))

Remote Controller Specifications

Model	RG10A(B2S)/BGEFU1
Rated Voltage	3.0V (Dry batteries R03/LR03x2)
Reaching Distance	8m
Environment Temperature Range	-5 °C ~60 °C (23 °F ~140 °F)

Buttons and Functions

ON/OFF
Turns the unit on or off.

TEMP ^
Increases temperature in 1°C (1°F) increments. Max. temperature is 30°C (86°F).
NOTE: Press together ∨ & ^ buttons at the same time for 3 seconds will alternate the temperature display between the °C & °F.

SET
Scrolls through operation functions as follows:
Fresh(🍃) → Sleep(🌙) → Follow Me(👤) → AP mode(📶) → Fresh...
The selected symbol will flash on the display area, press the OK button to confirm.

TEMP ∨
Decreases temperature in 1°C(1°F) increments. Min. temperature is 16°C(60°F).

FAN SPEED
Selects fan speeds in the following order: AU→20% →40%→60%→80%→100%.
Press the TEMP^ or ∨ button to increase/decrease the fan speed in 1% increments.

SWING
Starts and stops the horizontal louver movement. Hold down for 2 seconds to initiate vertical louver auto swing feature(some units).

BOOST
Enables unit to reach preset temperature in shortest possible time

MODE
Scrolls through operation modes as follows: **AUTO** → **COOL** → **DRY** → **HEAT** → **FAN**

ECO/GEAR
Press this button to enter the energy efficient mode in a sequence of following:
ECO → GEAR(75%) → GEAR(50%) → Previous setting mode → ECO

OK
Used to confirm the selected functions

TIMER
Set timer to turn unit on or off

BREEZE AWAY
This feature avoids direct air flow blowing on the body and makes you feel indulging in silky coolness.
NOTE: This feature is available under cool, Fan and Dry mode only

CLEAN
Used to start/stop the Self Clean or Active Clean function.(Model dependent, please refer to the USER'S OPERATION & INSTALLATION MANUAL for details)

LED
Turns indoor unit's LED display and air conditioner buzzer on and off(model dependent), which create a comfortable and quiet environment.

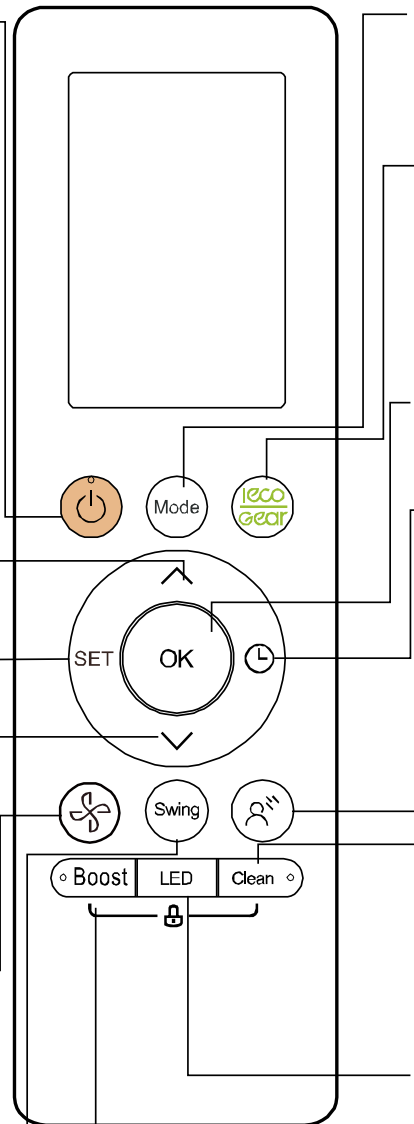

3.2 LCD Wired Remote Controller

3.2.1 LCD Wired Remote Controller KJR-12B/DP(T) (Standard)

The KJR-12B/DP(T) wired remote controller is standard for Duct type.

i) Buttons and Functions

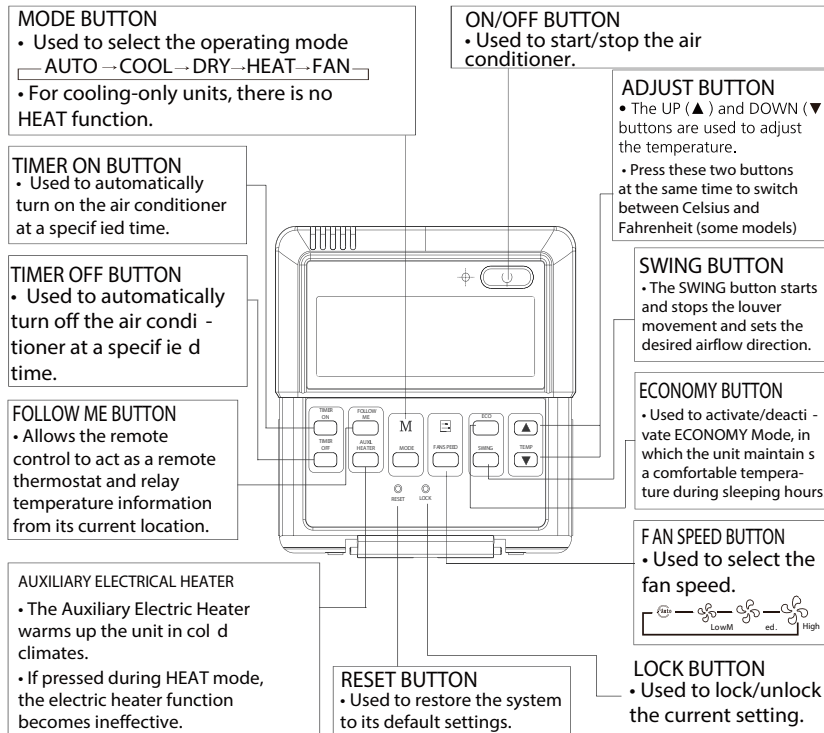

ii) LCD Screen

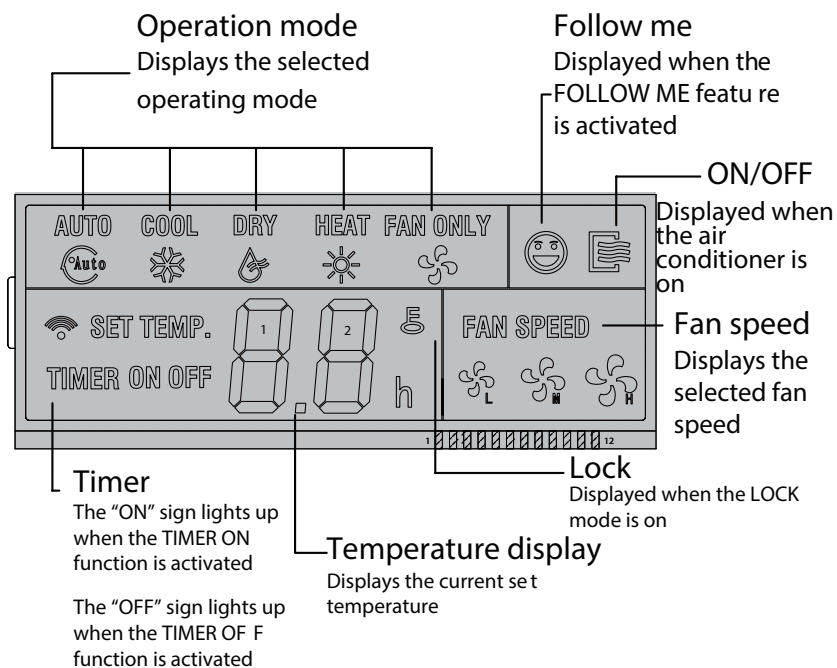

iii) Installation

- Dimensions

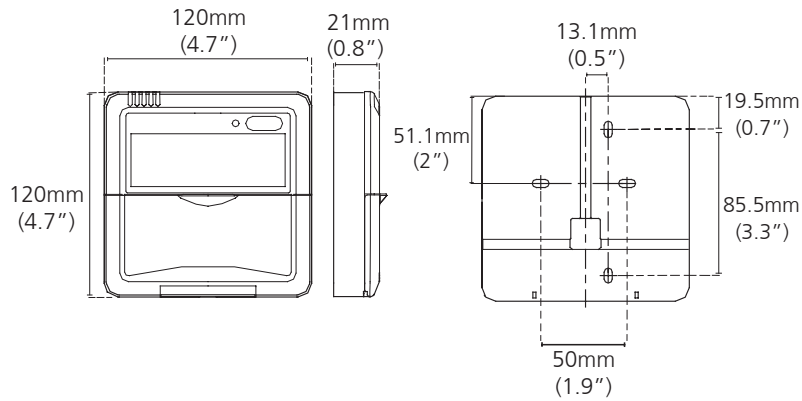

- Wiring diagram

Refer to the following diagram to wire the Wall mounted type remote control to the indoor unit.

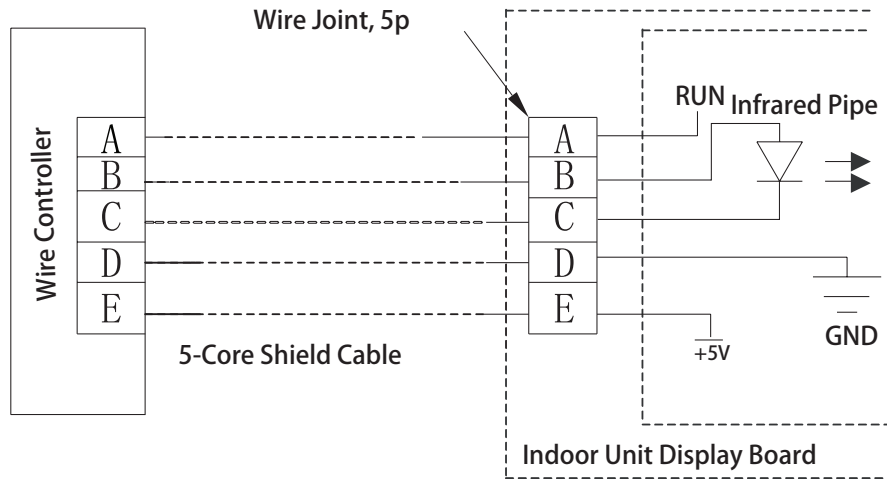

- Installation Diagram

Connect the wire from the display panel of the indoor unit to a connecting cable. Then connect the other side of the connecting cable to the remote control.

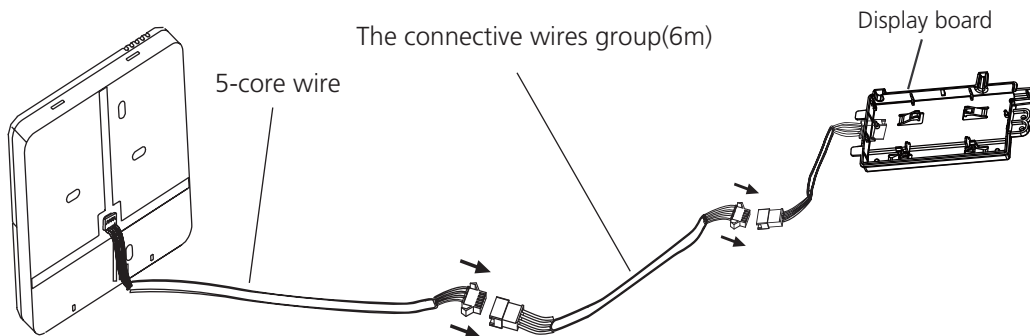

Note: Be sure to reserve a length of the connecting wire for periodic maintenance.

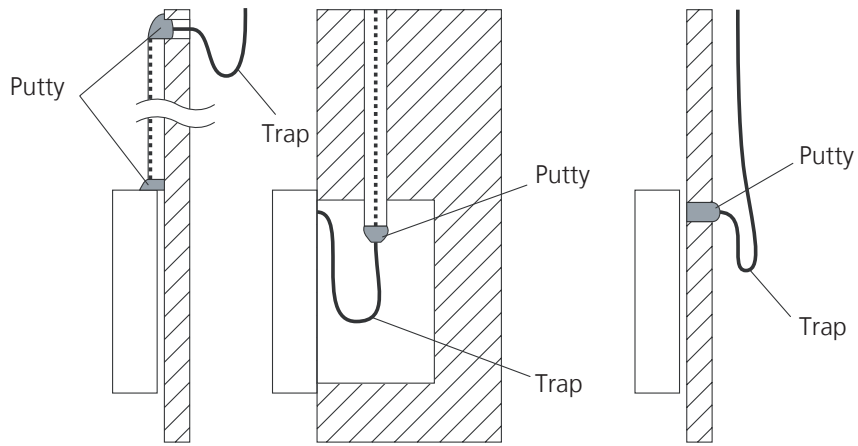

Note: DO NOT allow water to enter the remote control. Use the trap and putty to seal the wires.

- For exposed mounting, cut holes on four of the sides according to the picture below.

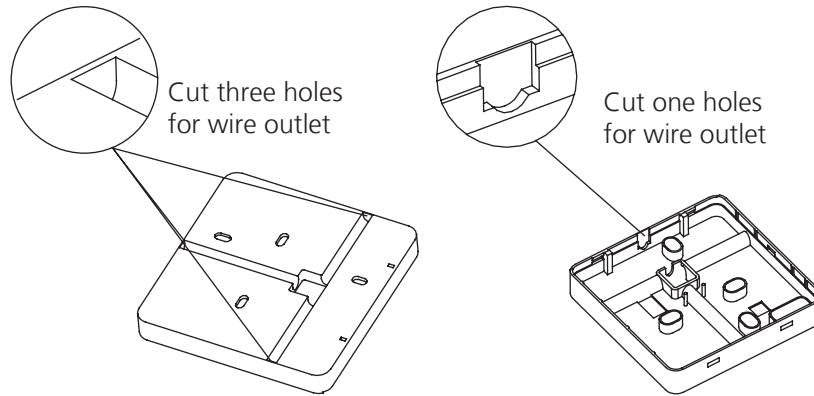

- For shielded wiring, please refer to the picture below.

Embedded switch box wiring

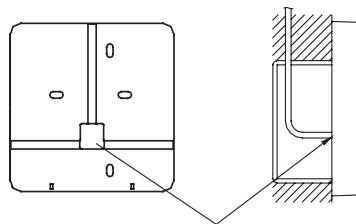

Wiring hole

Wiring through the wall

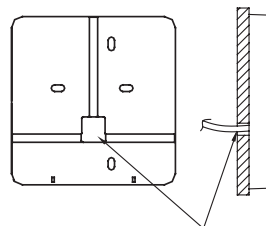

Wall hole and wiring hole
Diameter of wall hole: Φ 2cm

3.2.2 LCD Wired Remote Controller KJR-120C/TF-E(Optional)

The KJR-120C/TF-E wired remote controller is optional for all types.

i) Buttons and Functions

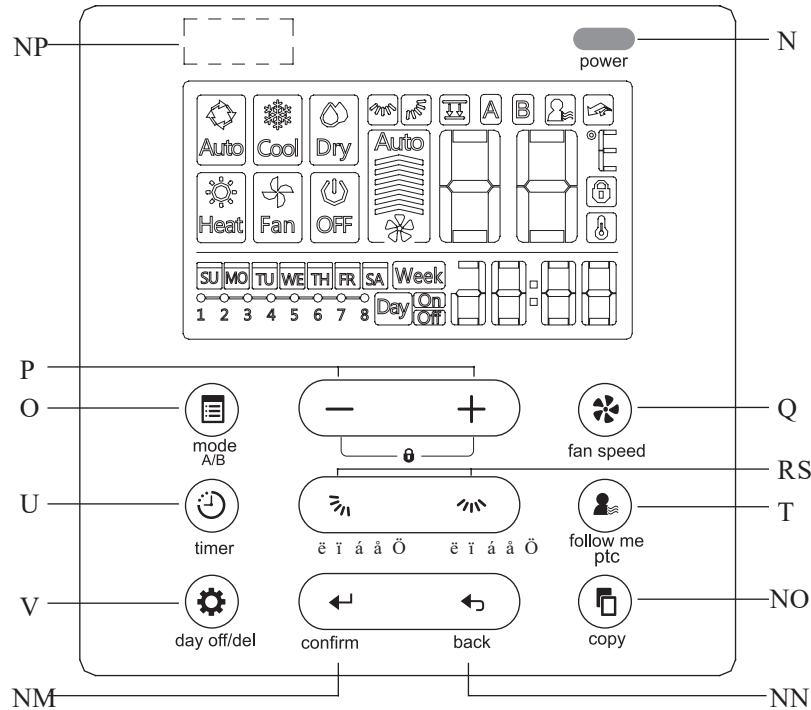

1. POWER button

Turn on or turn off the unit.

2. MODE(A/B) button

Used to select the operation mode: Auto / Cooling / Drying / Heating / Fan;

Hold to activate the operation of auto-lifting panel when off

3. Adjust button

To set temperature, time and timer; set up or down the auto-lifting panel

4. FAN SPEED button

Used to select the fan speed.

5. Up-down airflow direction and swing Button

Press for adjusting the angel of louver, hold for vertical swing; individual louver control for cassette panel

6. Left-right airflow swing Button

Press for activating the horizontal swing

7. FOLLOW ME(PTC) button

Allows the remote control to act as a remote thermostat and send temperature information from its current location.

8. TIMER button

To set timer on and timer off time of one day

9. DELAY/DAY OFF button

To set 1 to 2 hours delay off for each day or a whole day off in a weekly timer schedule

10. CONFIRM button

To confirm an setting or call up the menu

11. BACK button

Back to previous operation or superior menu

12. COPY button

Copy timer setting of one day to another in weekly schedule setting

13 Infrared remote receiver (on some models)

ii) LCD Screen

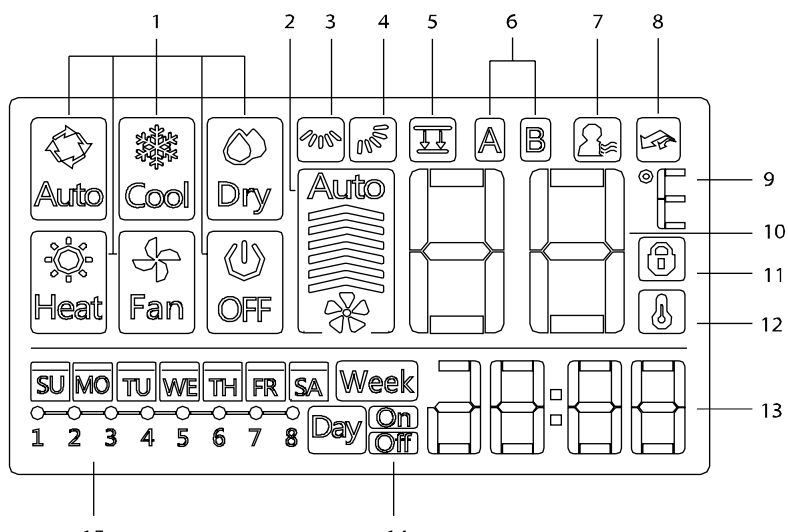

1 Operation mode indication

2 Fan speed indication

3 Left-right swing indication

4 Up-down swing indication

5 Faceplate function indication

6 Main unit and secondary unit indication

7 Follow me function indication

8 PTC function indication

9 C° / F° indication

10 Temperature display

11 Lock indication

12 Room temperature indication

13 Clock display

14 On/Off timer

15 Timer display

iii) Installation

- Dimensions

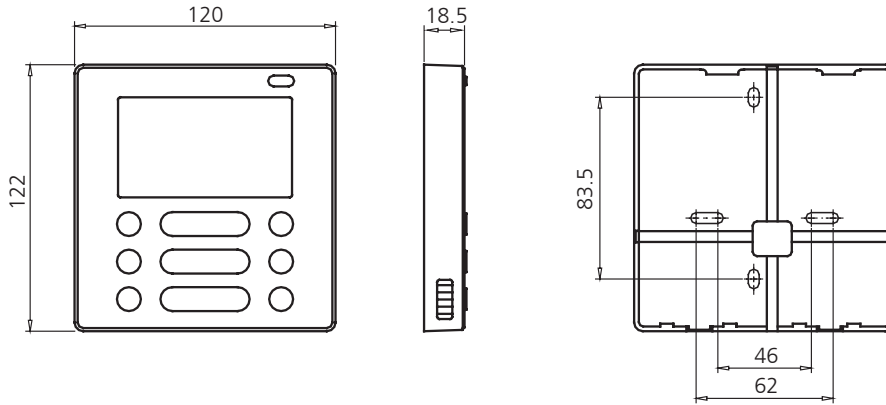

- Wiring diagram

Refer to the following diagram to wire the Wall mounted type remote control to the indoor unit.

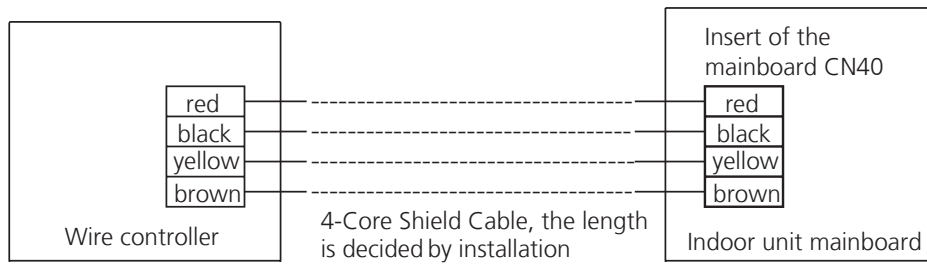

- Installation Diagram

Connect the female joint of wires group from the mainboard with the male joint of connective wires group. Then connect the other side of connective wires group with the male joint of wires group leads from wire controller.

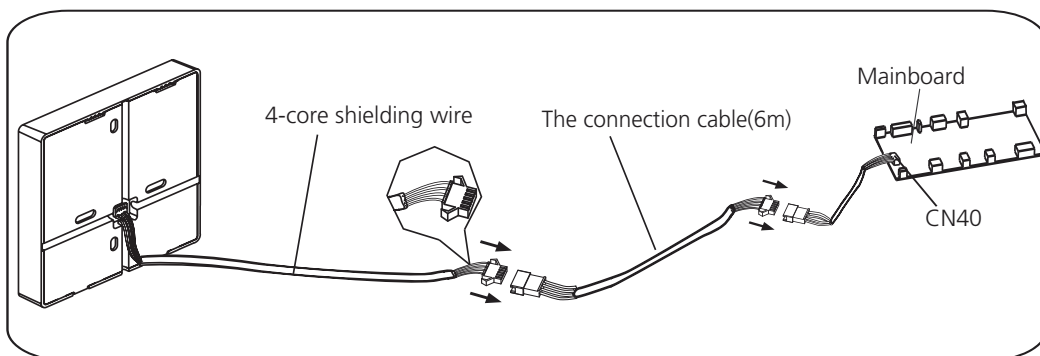

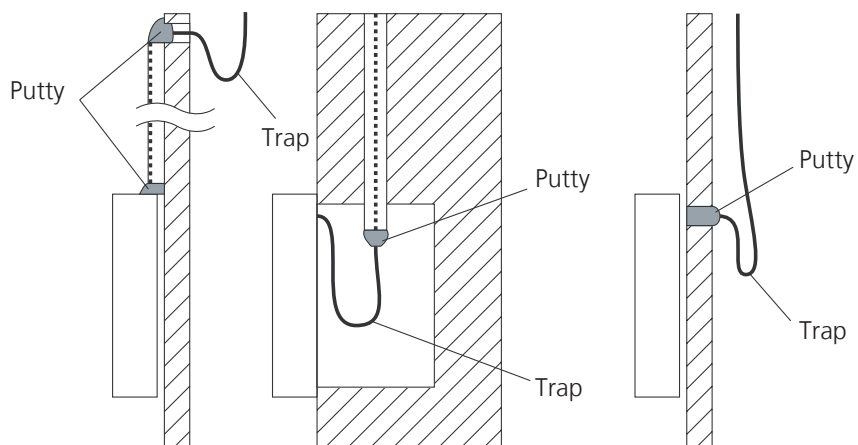

Note: DO NOT allow water to enter the remote control. Use the trap and putty to seal the wires.

- For exposed mounting, four outletting positions. There are three need cutting.

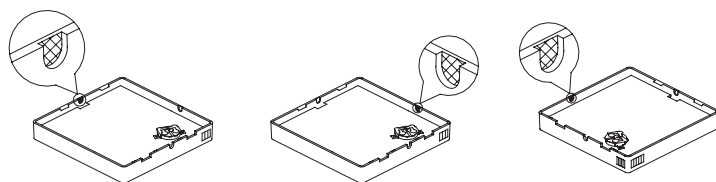

Cutting place of top side wire outlet

Cutting place of left side wire outlet

Cutting place of right side wire outlet

- For shielded wiring, please refer to the picture below.

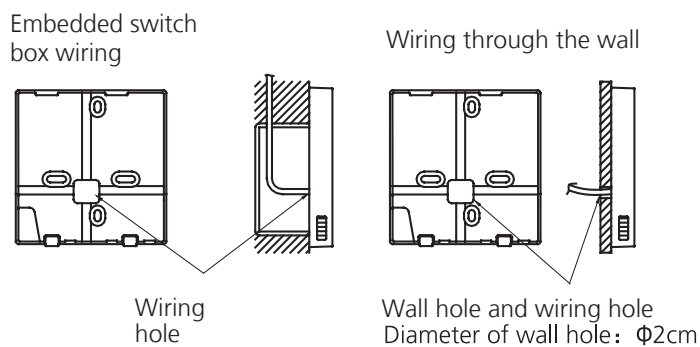

3.2.3 LCD Wired Remote Controller KJR-120G/TF-E(Optional)

The KJR-120G/TF-E wired remote controller is optional for all types.

i) Buttons and Functions

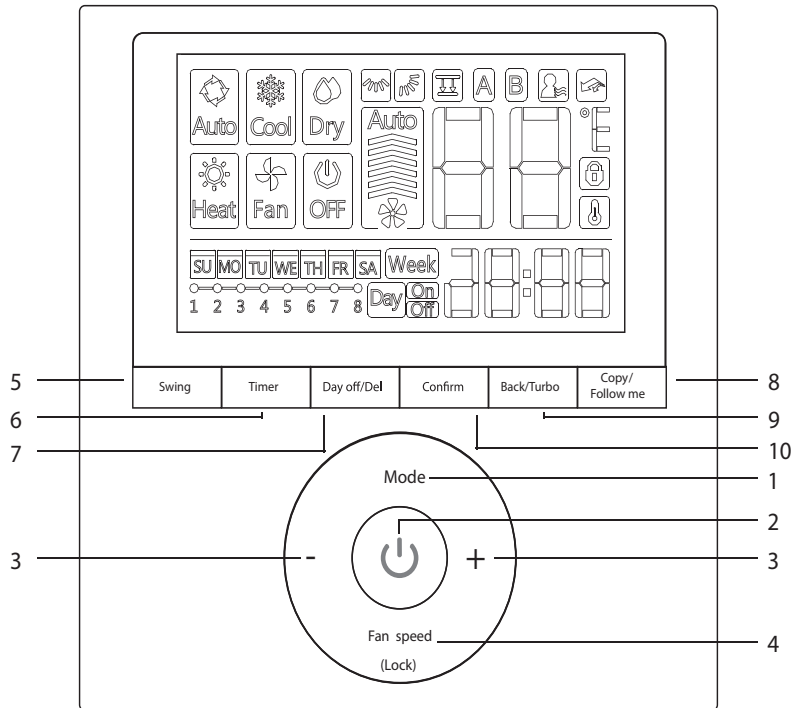

1. POWER button

Turn on or turn off the unit.

2. MODE button

Used to select the operation mode: Auto / Cooling / Drying / Heating / Fan;

3. DAY OFF/DEL button

To set 1 to 2 hours delay off for each day or a whole day off in a weekly timer schedule.

4. Adjust button

To set temperature, time and timer

5. CONFIRM button

To confirm an setting or call up the superior menu

6. TIMER button

To set timer on and timer off time of one day

7. FAN SPEED button

Used to select the fan speed.

8. BACK button

Back to previous operation or superior menu

9. Swing Button

Press to active vertical swing, hold for horizontal swing

10. FUNC. button

Press the FUNC. button to set the turbo or rotating or ifeel function.

11. COPY button

To copy timer setting of one day to another in weekly schedule setting.

ii) LCD Screen

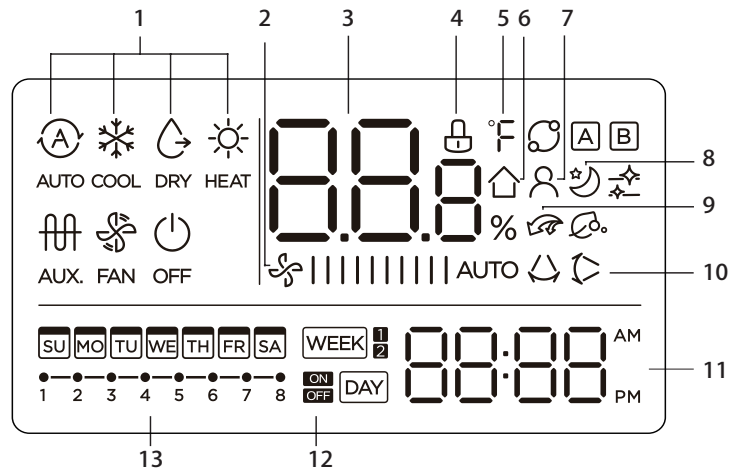

1 Operation mode indication

2 Fan speed indication

3 Temperature display

4 Lock indication

5 °C / °F indication

6 Room temperature indication

7 Follow Me function indication

8 Sleep mode indication

9 Electric Auxiliary Heat/Turbo function indication(some models)

NOTE: AHU models only have turbo functions.

10 Left-right swing indication (some models)

11 Clock display

12 On/Off timer

13 Timer display

iii) Installation

• Dimensions

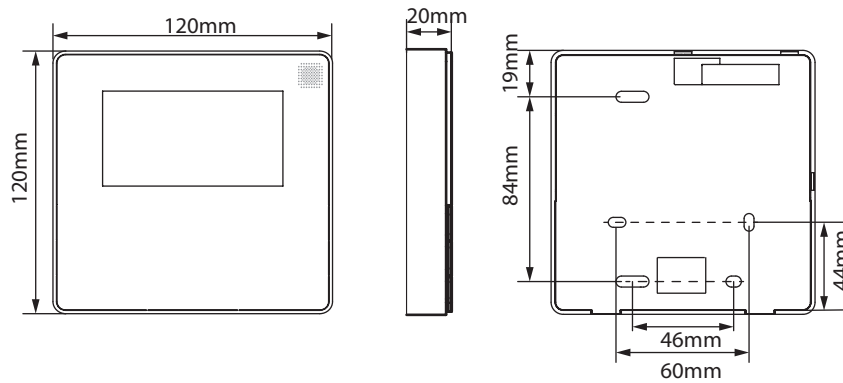

1) Connection

• Wire with the indoor unit:

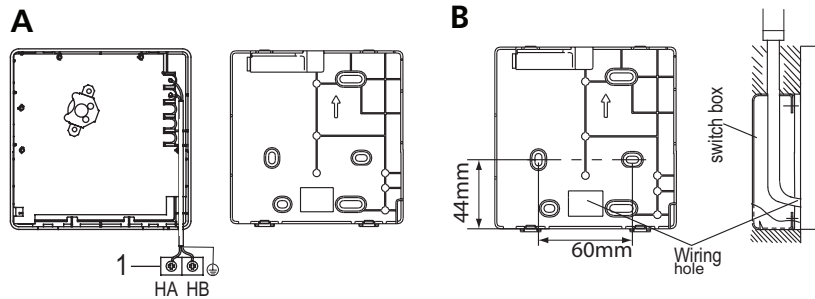

- 1: Indoor Unit.
- 2: Notch the part for the wiring to pass through with a nipper tool.
- Connect the terminals on the remote controller (HA ,HB), and the terminals of the indoor unit. (HA ,HB). (HA and HB do not have polarity.)

For some models: The wired controller connects to main control board directly.

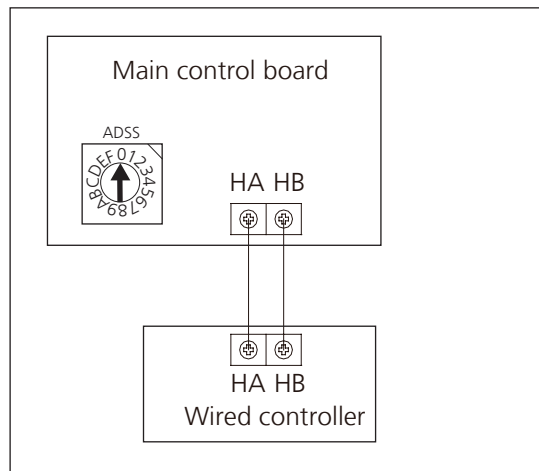

For some models: The wired controller connects to terminal board, terminal board connects to main control board.

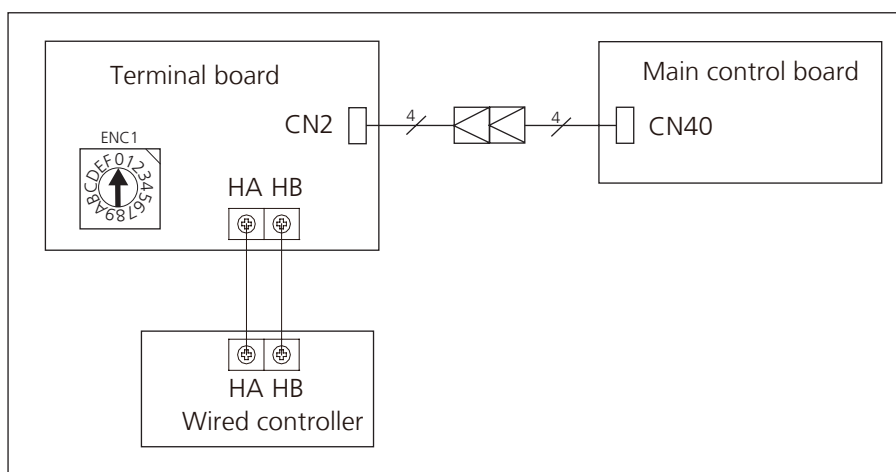

2) Address setting

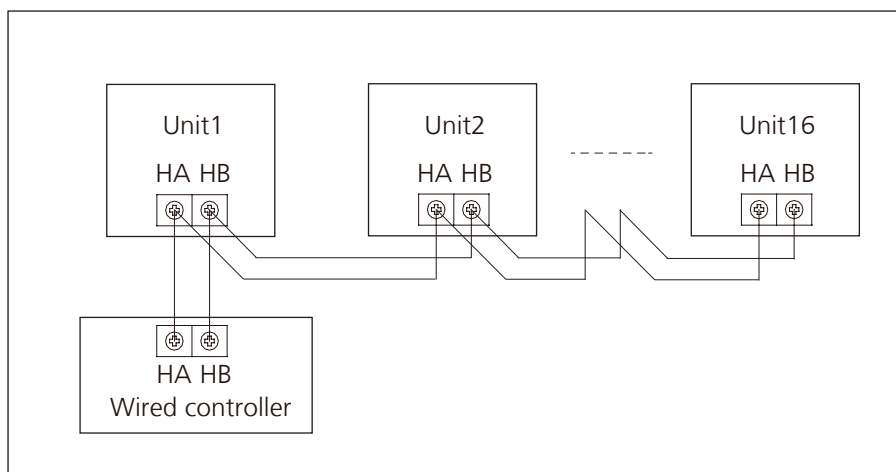

- a. One non-polarity controller can control up to 16 indoor units.
- b. When the non-polarity controller is connected to several units, every air-conditioner in network has only one network address to distinguish each other.
- c. Address code of air-conditioner in LAN is set by code switch ENC1(Duct and Ceiling& Floor) or ADSS(Cassette) of the indoor unit, and the set range is 0-15.
- d. Note: The indoor units are controlled at the same time, not independently. The purpose of setting network address is identify the unit when error occurs.

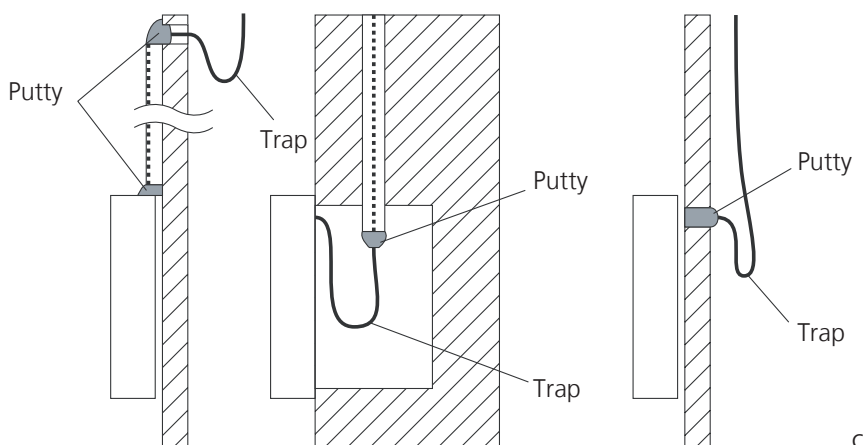

Note: DO NOT allow water to enter the remote control. Use the trap and putty to seal the wires.

3.3 Centralized Controller

1) Connection

For Light commercial air conditioner with XYE port, it can be directly connected to Centralized Controller (CCM03, CCM09).

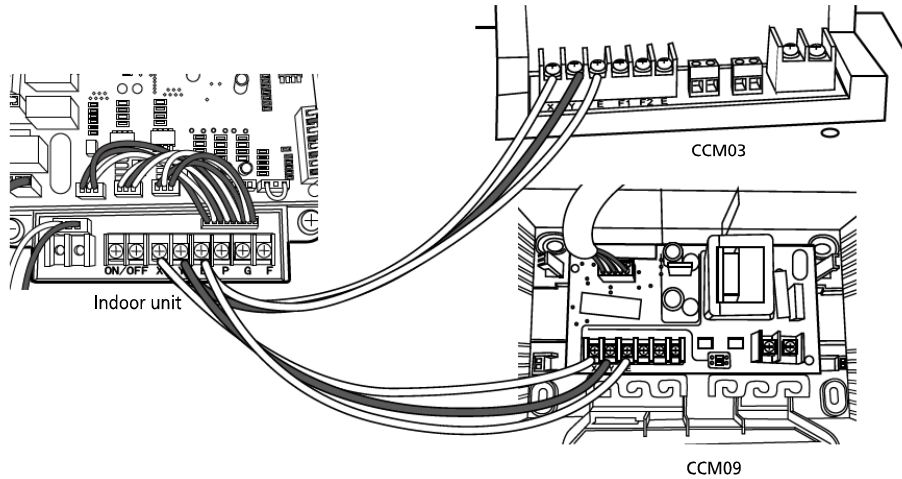

2) Address setting

When setting the address, please make sure the unit is powered off. The address can be set from 0 to 63 by the switch. Turn on the unit, then the address will be effective.

SWITCH		FOR CCM UNIT ADDRESS	
S2 + S1			
ADDRESS	0~15	16~31	
Factory Setting	✓		
S2 + S1			
ADDRESS	32~47	48~63	
Factory Setting			

Note: For light commercial air conditioner with XYE port, it can be also connected to BMS (Building Management System).

If there is any CAC (central air conditioner) connecting with the central controller at the same time, please set the address from largest (63,62,61...), since the CAC units could obtain address automatically from the smallest (00,01,02...)

3.4 Using the wire controller to set external static pressure

- You can use the unit’s automatic airflow adjustment function to set external static pressure.
- Automatic airflow adjustment is the volume of blow-off air that has been automatically adjusted to the quantity rated.

1. Make sure the test run is done with a dry coil. If the coil is not dry, run the unit for 2 hours in FAN ONLY mode to dry the coil.

2. Check that both power supply wiring and duct installation have been completed. Check that any closing dampers are open. Check that the air filter is properly attached to the air suction side passage of the unit.

3. If there is more than one air inlet and outlet, adjust the dampers so that the airflow rate of each air inlet and outlet conforms with the designed airflow rate. Make sure the unit is in FAN ONLY mode. Press and set the airflow adjustment button on the remote control to change the airflow rate from H or L.

4. Set the parameters for automatic airflow adjustment. When the air conditioning unit is off, perform the following steps:

- When the unit is turned off, hold the MODE button and FAN button down together for three seconds. (“AF” indicator flashes for 3 times.)

- Press “Δ” or “∇” to select the AF.

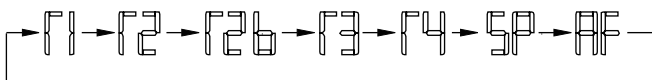

- Press “MODE”. The air conditioning unit will then start the fan for airflow automatic adjustment.

After 3 to 6 minutes, the air conditioning unit stops operating once automatic airflow adjustment has finished.

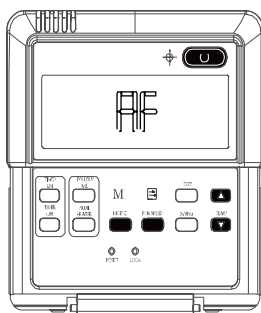

Caution: DO NOT adjust the dampers when automatic airflow adjustment is active.

Caution:

• If there is no change after airflow adjustment in the ventilation paths, be sure to reset automatic airflow adjustment.

• If there is no change to ventilation paths after airflow adjustment, contact your dealer, especially if this occurs after testing the outdoor unit or if the unit has been moved to a different location.

• Do not use automatic airflow adjustment with remote control, if you are using booster fans, outdoor air processing unit, or a HRV via duct.

• If the ventilation paths have been changed, reset airflow automatic adjustment as described from step 3 onwards.

3.5 Using the wire controller to set airflow rate

When the air conditioning unit is off, perform the following steps:

1. Press “MODE” and “FAN” for three seconds.

2. Press “Δ” or “∇” to select the SP.

3. Press “MODE” to set the airflow rate in the range of 0~4.

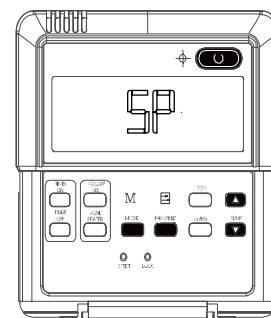

“0”: No airflow change

“1”~“4”: Airflow increase progressively

4. Press “ON/OFF” to finish the airflow setting.

Troubleshooting

Contents

1.	Safety Caution	176
2.	General Troubleshooting	177
2.1	Error Display (Indoor Unit).....	177
2.2	Error Display (Outdoor Unit).....	181
3.	Outdoor Unit Point Check Function	182
4.	Error Diagnosis and Troubleshooting Without Error Code.....	188
4.1	Remote maintenance.....	188
4.2	Field maintenance	189
5.	Troubleshooting by Error Code.....	194
	TS01-IDU: Indoor EEPROM parameter error diagnosis and solution	
	TS01-ODU: Outdoor EEPROM parameter error or Compressor driven chip EEPROM parameter error diagnosis and solution	
	TS02-M: Indoor and outdoor units communication error diagnosis and solution	
	TS03 Zero-crossing Signal Detection Error Diagnosis and Solution	
	TS04-L-IDU: The Indoor fan speed is operating outside of normal range diagnosis and solution)	
	TS04-ODU: The outdoor fan speed is operating outside of normal range diagnosis and solution)	
	TS05-IDU: Open circuit or short circuit of indoor temperature sensor(T1, T2) diagnosis and solution	
	TS05-ODU: Open circuit or short circuit of outdoor temperature sensor(T3, T4, TP, T2B,TH) diagnosis and solution	
	TS08-L-INV: Current overload protection diagnosis and solution	
	TS09-L: IPM malfunction or IGBT over-strong current protection or Inverter compressor	

Contents

drive error diagnosis and solution

TS10-L: Over voltage or too low voltage protection diagnosis and solution

TS11-L: Top temperature protection of compressor diagnosis and solution

TS14: Indoor units mode conflict (match with multi outdoor unit)

TS15: Water-Level Alarm Malfunction Diagnosis and Solution

TS23: Communication error between indoor two chips diagnosis and solution

TS13-INV: Low pressure protection diagnosis and solution

TS28: High pressure protection diagnosis and solution

TS31: Communication error between outdoor main PCB and IPM board diagnosis and solution

TS32: Discharge temperature protection of compressor diagnosis and solution

TS27-INV: High temperature protection of condenser diagnosis and solution

TS30: PFC module protection diagnosis and solution

TS07: Indoor PCB/Display Board Communication Error Diagnosis and Solution

TS38: Lack phase failure of outdoor DC fan motor diagnosis and solution

TS39: Outdoor compressor lack phase protection diagnosis and solution

TS40: Outdoor unit IR chip drive failure diagnosis and solution

TS41: Communication malfunction between adapter board and outdoor main board diagnosis and solution

TS44: Communication malfunction between external fan module and indoor unit or External fan DC bus voltage is too low protection or External fan DC bus voltage is too high fault diagnosis and solution

6. Check Procedures.....235

1. Safety Caution

⚠ WARNING

Be sure to turn off all power supplies or disconnect all wires to avoid electric shock. While checking indoor/outdoor PCB, please equip oneself with antistatic gloves or wrist strap to avoid damage to the board.

⚠ WARNING

Electricity remains in capacitors even when the power supply is off. Ensure the capacitors are fully discharged before troubleshooting.

Test the voltage between P and N on back of the main PCB with multimeter. If the voltage is lower than 36V, the capacitors are fully discharged.

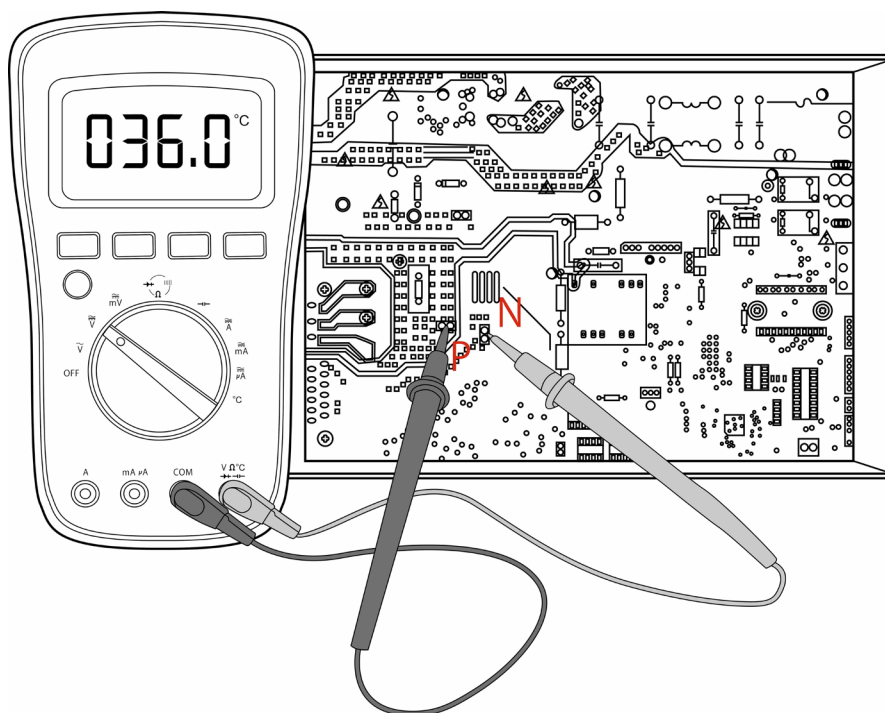

Note: This picture is for reference only. Actual appearance may vary.

2. General Troubleshooting

2.1 Error Display (Indoor Unit)

When the indoor unit encounters a recognized error, the operation lamp will flash in a corresponding series, the timer lamp may turn on or begin flashing, and an error code will be displayed. These error codes are described in the following tables:

For Aurora(30k,36k), Compact Cassette, Floor Ceiling, A6 Duct

Operation Lamp	Timer Lamp	Display	Error Information	Solution
--	--	dF	Defrost	Normal Display, not error code
--	--	CF	Warming in heating mode	
--	--	SC	Self clean	
--	--	CL	Clean filter	
--	--	RF	Replacing filter	
--	--	FP	Heating in room temperature under 8°C	
--	--	FC	Forced cooling	
--	--	RP	AP mode of WIFI connection	
--	--	CP	Remote switched off	
1 time	OFF	E0	Indoor unit EEPROM parameter error	TS01-IDU
2 times	OFF	E1	Indoor / outdoor units communication error	TS02-M
4 times	OFF	E3	The indoor fan speed is operating outside of the normal range	TS04-L-IDU
5 times	OFF	E4	Indoor room temperature sensor T1 is in open circuit or has short circuited	TS05-IDU
6 times	OFF	E5	Evaporator coil inlet temperature sensor T2 is in open circuit or has short circuited	TS05-IDU
8 times	OFF	EE	Water-level alarm malfunction(for some models)	TS15
1 times	ON	F0	Current overload protection	TS08-L-INV
2 times	ON	F1	Outdoor room temperature sensor T4 is in open circuit or has short circuited	TS05-ODU
3 times	ON	F2	Condenser coil temperature sensor T3 is in open circuit or has short circuited	TS05-ODU
4 times	ON	F3	Compressor discharge temperature sensor TP is in open circuit or has short circuited	TS05-ODU
5 times	ON	F4	Outdoor unit EEPROM parameter error	TS01-ODU
6 times	ON	F5	The outdoor fan speed is operating outside of the normal range(for some models)	TS04-ODU
7 times	ON	F6	Evaporator coil outlet temperature sensor T2B is in open circuit or has short circuited	TS05-ODU
11 times	ON	FR	Communication error between indoor two chips (for some models)	TS23
1 times	FLASH	PG	IPM malfunction or IGBT over-strong current protection	TS09-L

2 times	FLASH	P1	Over voltage or over low voltage protection	TS10-L
3 times	FLASH	P2	High temperature protection of IPM module or High pressure protection or Top temperature protection of compressor	TS11-L
4 times	FLASH	P3	Low ambient temperature protection	--
5 times	FLASH	P4	Inverter compressor drive error	TS09-L
6 times	FLASH	--/P5	Indoor units mode conflict	TS14
7 times	FLASH	P6	High pressure protection or low pressure protection	TS28/ TS13-INV
8 times	FLASH	P7	Outdoor IGBT sensor is faulty(for some models)	TS05- ODU

For Air handler type,

Display	Error Information	Solution
EH00	Indoor unit EEPROM parameter error	TS01-IDU
EL01	Indoor / outdoor unit communication error	TS02-M
EL16	Communication malfunction between adapter board and outdoor main board	TS41
EH03	The indoor fan speed is operating outside of the normal range	TS04-L- IDU
EH60	Indoor room temperature sensor T1 is in open circuit or has short circuited	TS05-IDU
EH61	Evaporator coil temperature sensor T2 is in open circuit or has short circuited	TS05-IDU
EH62	Evaporator coil temperature sensor T2B is in open circuit or has short circuited(for some models)	TS05-IDU
EH65	Evaporator coil temperature sensor T2A is in open circuit or has short circuited(for some models)	TS05-IDU
EH0b	Communication error between indoor two chips	TS23
EH0E	Water-level alarm malfunction	TS15
EC53	Outdoor room temperature sensor T4 is in open circuit or has short circuited	TS05- ODU
EC52	Condenser coil temperature sensor T3 is in open circuit or has short circuited	TS05- ODU
EC54	Compressor discharge temperature sensor TP is in open circuit or has short circuited	TS05- ODU
EC56	Evaporator coil outlet temperature sensor T2B is in open circuit or has short circuited	TS05- ODU
EC51	Outdoor unit EEPROM parameter error	TS01- ODU
EC07	The outdoor fan speed is operating outside of the normal range(for some models)	TS04- ODU
PC00	IPM malfunction or IGBT over-strong current protection	TS09-L
PC01	Over voltage or over low voltage protection	TS10-L
PC02	Top temperature protection of compressor or High temperature protection of IPM module	TS11-L
PC04	Inverter compressor drive error	TS09-L
PC03	High pressure protection or low pressure protection	TS28/ TS13-INV
PC0L	Low ambient temperature protection	--
--	Indoor units mode conflict(match with multi outdoor unit)	TS14

For other models,

Running Lamp	Timer Lamp	Display	Information	Solution
--	--	dF	Defrost	Normal Display, not error code
--	--	SC	Self clean(for some units)	
--	--	CL	Filter cleaning reminder(power on display for 15 seconds)	
--	--	CL	Active clean(for some units)	
--	--	nF	Filter replacement reminder(power on display for 15 seconds)	
--	--	FP	Heating in room temperature under 8°C/12°C	
--	--	FC	Forced cooling	
--	--	RP	AP mode of WIFI connection	
--	--	CP	Remote switched off	
1 time	OFF	E400/E40A	Indoor unit EEPROM parameter error	TS01-IDU
2 times	OFF	E401	Indoor/outdoor unit communication error	TS02-M
4 times	OFF	E403	The indoor fan speed is operating outside of the normal range	TS04-L-IDU
5 times	OFF	E451	Outdoor unit EEPROM parameter error	TS01-ODU
5 times	OFF	E452	Condenser coil temperature sensor T3 is in open circuit or has short circuited	TS05-ODU
5 times	OFF	E453	Outdoor room temperature sensor T4 is in open circuit or has short circuited	TS05-ODU
5 times	OFF	E454	Compressor discharge temperature sensor TP is in open circuit or has short circuited	TS05-ODU
5 times	OFF	E456	Evaporator coil outlet temperature sensor T2B is in open circuit or has short circuited	TS05-ODU
6 times	OFF	E460	Indoor room temperature sensor T1 is in open circuit or has short circuited	TS05-IDU
6 times	OFF	E461	Evaporator coil middle temperature sensor T2 is in open circuit or has short circuited	TS05-IDU
12 times	OFF	E407	The outdoor fan speed is operating outside of the normal range	TS04-ODU
13 times	OFF	E40E	Water-level alarm malfunction(for some models)	TS15
9 times	OFF	E40b	Indoor PCB/Display board communication error(for some models)	TS07
7 times	FLASH	PC00	IPM malfunction or IGBT over-strong current protection	TS09-L
2 times	FLASH	PC01	Over voltage or over low voltage protection	TS10-L
3 times	FLASH	PC02	Top temperature protection of compressor or High temperature protection of IPM module or High pressure protection	TS11-L
5 times	FLASH	PC04	Inverter compressor drive error	TS09-L
7 times	FLASH	PC03	High pressure protection or low pressure protection	TS28/TS13-INV
4 times	FLASH	PC0L	Low ambient temperature protection	--
1 times	ON	--	Indoor units mode conflict(match with multi outdoor unit)	TS14
--	--	E4bA	Communication malfunction between external fan module and indoor unit	TS44
4 times	OFF	E43A	External fan DC bus voltage is too low protection	TS44
4 times	OFF	E43B	External fan DC bus voltage is too high fault	TS44

For other errors:

The display board may show a garbled code or a code undefined by the service manual. Ensure that this code is not a temperature reading.

Troubleshooting:

Test the unit using the remote control. If the unit does not respond to the remote, the indoor PCB requires replacement.

If the unit responds, the display board requires replacement.

88 flash frequency:

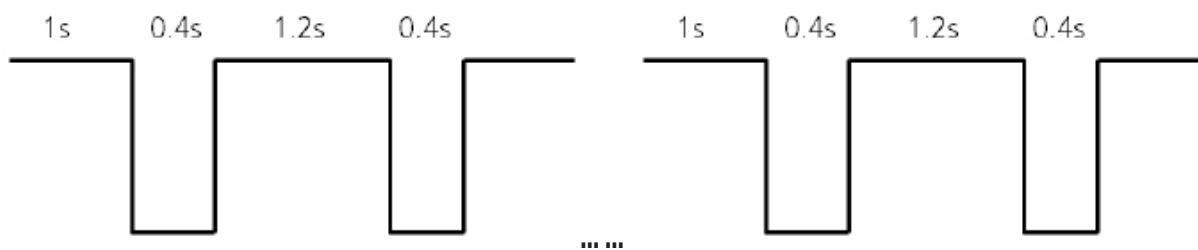

Troubleshooting:

Test the unit using the remote control. If the unit does not respond to the remote, the indoor PCB requires replacement. If the unit responds, the display board requires replacement.

2.2 Error Display (Outdoor Unit)

Display	Malfunction or Protection	Solution
dF	Defrosting	Normal Display, not error code
FC	Forced cooling	
EE 51	Outdoor EEPROM malfunction	TS01-ODU
EL 01	Indoor / outdoor units communication error	TS02-M
PC 40	Communication malfunction between IPM board and outdoor main board	TS31
PC 08	Outdoor overcurrent protection	TS08-L-INV
PC 10	Outdoor unit low AC voltage protection	TS10-L
PC 11	Outdoor unit main control board DC bus high voltage protection	TS10-L
PC 12	Outdoor unit main control board DC bus high voltage protection /341 MCE error	TS10-L
PC 00	IPM module protection	TS09-L
PC 0F	PFC module protection	TS30
EE 71	Over current failure of outdoor DC fan motor	TS04-ODU
EE 72	Lack phase failure of outdoor DC fan motor	TS38
EE 07	Outdoor fan speed has been out of control	TS04-ODU
PC 43	Outdoor compressor lack phase protection	TS39
PC 44	Outdoor unit zero speed protection	TS08-L-INV
PC 45	Outdoor unit IR chip drive failure	TS40
PC 46	Compressor speed has been out of control	TS08-L-INV
PC 49	Compressor overcurrent failure	TS08-L-INV
PC 30	High pressure protection	TS28
PC 31	Low pressure protection	TS13-INV
PC 0A	High temperature protection of condenser	TS27-INV
PC 06	Temperature protection of compressor discharge	TS32
PC 02	Top temperature protection of compressor	TS11-L
EE 52	Condenser coil temperature sensor T3 is in open circuit or has short circuited	TS05-ODU
EE 53	Outdoor room temperature sensor T4 is in open circuit or has short circuited	TS05-ODU
EE 54	Compressor discharge temperature sensor TP is in open circuit or has short circuited	TS05-ODU
EE 56	Evaporator coil outlet temperature sensor T2B is in open circuit or has short circuited	TS05-ODU
EE 50	Open or short circuit of outdoor unit temperature sensor(T3,T4.TP)	TS05-ODU
LC 06	IPM module frequency limit shutdown/IPM high temperature protection	--
PC 0L	Low ambient temperature protection	--

3. Outdoor Unit Point Check Function

For M2OA-18HFN1-M,

- A check switch is included on the key board.
- Push SW1 to check the unit's status while running. The digital display shows the following codes each time the SW1 is pushed.

Number of Presses	Display	Remark
0	Normal display	Displays running frequency, running state, or malfunction code
1	Quantity of indoor units with working connection	Display Number of indoor unit 1 1 2 2 3 3 4 4
2	Outdoor unit running mode code	Standby: 0, Fan only: 1, Cooling: 2, Heating: 3, Forced cooling: 4, Forced defrosting: A
3	Indoor unit A capacity	The capacity unit is horse power. If the indoor unit is not connected, the digital display shows the following: "--" (9K:1HP,12K:1.2HP,18K:1.5HP)
4	Indoor unit B capacity	
5	Indoor unit C capacity	
6	Indoor unit D capacity	
7	Indoor unit E capacity	
8	Indoor unit A capacity demand code	Norm code*HP (9K: 1HP,12K: 1.2HP,18K: 1.5HP)
9	Indoor unit B capacity demand code	
10	Indoor unit C capacity demand code	
11	Indoor unit D capacity demand code	
12	Indoor unit E capacity demand code	
13	Outdoor unit amendatory capacity demand code	
14	The frequency corresponding to the total indoor units' amendatory capacity demand	
15	The frequency after the frequency limit	
16	The frequency sending to compressor control chip	

17	Indoor unit A evaporator outlet temperature (T2BA)	If the temperature is lower than -9°C, the digital display shows "-9." If the temperature is higher than 70°C, the digital display shows "70." If the indoor unit is not connected, the digital display shows: "--"
18	Indoor unit B evaporator outlet temperature (T2BB)	
19	Indoor unit C evaporator outlet temperature (T2BC)	
20	Indoor unit D evaporator outlet temperature (T2BD)	
21	Indoor unit E evaporator outlet temperature (T2BE)	
22	Indoor unit A room temperature (T1A)	If the temperature is lower than 0°C, the digital display shows "0." If the temperature is higher than 70°C, the digital display shows "70." If the indoor unit is not connected, the digital display shows: "--"
23	Indoor unit B room temperature (T1B)	
24	Indoor unit C room temperature (T1C)	
25	Indoor unit D room temperature (T1D)	
26	Indoor unit E room temperature (T1E)	
27	Indoor unit A evaporator temperature (T2A)	If the temperature is lower than -9°C, the digital display shows "-9." If the temperature is higher than 70°C, the digital display shows "70." If the indoor unit is not connected, the digital display shows: "--"
28	Indoor unit B evaporator temperature (T2B)	
29	Indoor unit C evaporator temperature (T2C)	
30	Indoor unit D evaporator temperature (T2D)	
31	Indoor unit E evaporator temperature (T2E)	
32	Condenser pipe temperature (T3)	
33	Outdoor ambient temperature (T4)	The display value is between 30–129°C. If the temperature is lower than 30°C, the digital display shows "30." If the temperature is higher than 99°C, the digital display shows single and double digits. For example, if the digital display shows "0.5", the compressor discharge temperature is 105°C.
34	Compressor discharge temperature (TP)	

35	AD value of current	The display value is a hex number. For example, the digital display tube shows "Cd", it means AD value is 205.		
36	AD value of AC voltage			
37	AD value of DC voltage			
38	EXV open angle for A indoor unit	Actual data/4. If the value is higher than 99, the digital display shows single and double digits. For example, if the digital display shows "2.0", the EXV open angle is $120 \times 4 = 480p$.		
39	EXV open angle for B indoor unit			
40	EXV open angle for C indoor unit			
41	EXV open angle for D indoor unit			
42	EXV open angle for E indoor unit			
43	MVI valve open angle			
44	EVI valve open angle			
45	Frequency limit symbol	Bit7	Frequency limit caused by IGBT radiator	The display value is a hexadecimal number. For example, the digital display show 2A, then Bit5=1, Bit3=1, and Bit1=1. This means that a frequency limit may be caused by current, IPM or T3.
		Bit6	Frequency limit caused by PFC	
		Bit5	Frequency limit caused by T4.	
		Bit4	Frequency limit caused by T2.	
		Bit3	Frequency limit caused by T3.	
		Bit2	Frequency limit caused by T5.	
		Bit1	Frequency limit caused by current	
		Bit0	Frequency limit caused by voltage	
46	T2B fault	00:No fault,01:T2B-A fault, ,02:T2B-B fault ,03:T2B-C fault,04:T2B-D fault, 05:T2B-E fault, 06:T2B-F fault(The display priority is A-B-C-D-E-F)		
47	Average value of T2	(Sum T2 value of all indoor units)/(number of indoor units in good connection)(The heating is the average value of T2, and the cooling is the average value of T2B)		
48	Outdoor unit fan motor state	Off: 0, Super ultra high speed:1, Super high speed:2, High speed:3, Med speed: 4, Low speed: 5, Breeze:6, Super breeze: 7		
49	Reason of stop			

For M3OJ-27HFN1-M, M4OG-36HFN1-M, M5OG-48HFN1-M

- A check switch is included on the outdoor PCB.
- Push SW1 to check the unit's status while running. The digital display shows the following codes each time the SW1 is pushed.

Number of Presses	Display	Remark
0	Normal display	Displays running frequency, running state, or malfunction code
1	Quantity of indoor units with working connection	Display Number of indoor unit 1 1 2 2 3 3 4 4
2	Outdoor unit running mode code	Standby: 0, Fan only: 1, Cooling: 2, Heating: 3, Forced cooling: 4, Forced defrosting: A
3	Indoor unit A capacity	The capacity unit is horse power. If the indoor unit is not connected, the digital display shows the following: "--" (9K: 1HP, 12K: 1.2HP, 18K: 1.5HP)
4	Indoor unit B capacity	
5	Indoor unit C capacity	
6	Indoor unit D capacity	
7	Indoor unit E capacity	
8	Indoor unit A capacity demand code	Norm code*HP (9K: 1HP, 12K: 1.2HP, 18K: 1.5HP)
9	Indoor unit B capacity demand code	
10	Indoor unit C capacity demand code	
11	Indoor unit D capacity demand code	
12	Indoor unit E capacity demand code	
13	Outdoor unit amendatory capacity demand code	
14	The frequency corresponding to the total indoor units' amendatory capacity demand	
15	The frequency after the frequency limit	
16	The frequency sending to compressor control chip	
17	Indoor unit A evaporator outlet temperature (T2BA)	If the temperature is lower than -9°C, the digital display shows "-9." If the temperature is higher than 70°C, the digital display shows "70." If the indoor unit is not connected, the digital display shows "--"
18	Indoor unit B evaporator outlet temperature (T2BB)	
19	Indoor unit C evaporator outlet temperature (T2BC)	
20	Indoor unit D evaporator outlet temperature (T2BD)	
21	Indoor unit E evaporator outlet temperature (T2BE)	

22	Indoor unit A room temperature (T1A)	If the temperature is lower than 0°C, the digital display shows "0." If the temperature is higher than 70°C, the digital display shows "70." If the indoor unit is not connected, the digital display shows: "--"
23	Indoor unit B room temperature (T1B)	
24	Indoor unit C room temperature (T1C)	
25	Indoor unit D room temperature (T1D)	
26	Indoor unit E room temperature (T1E)	
27	Indoor unit A evaporator temperature (T2A)	If the temperature is lower than -9°C, the digital display shows "-9." If the temperature is higher than 70°C, the digital display shows "70." If the indoor unit is not connected, the digital display shows: "--"
28	Indoor unit B evaporator temperature (T2B)	
29	Indoor unit C evaporator temperature (T2C)	
30	Indoor unit D evaporator temperature (T2D)	
31	Indoor unit E evaporator temperature (T2E)	
32	Condenser pipe temperature (T3)	
33	Outdoor ambient temperature (T4)	The display value is between 30–129°C. If the temperature is lower than 30°C, the digital display shows "30." If the temperature is higher than 99°C, the digital display shows single and double digits. For example, if the digital display shows "0.5", the compressor discharge temperature is 105°C.
34	Compressor discharge temperature (TP)	
35	AD value of current	The display value is a hex number.
36	AD value of voltage	For example, the digital display tube shows "Cd", it means AD value is 205.
37	EXV open angle for A indoor unit	Actual data/4. If the value is higher than 99, the digital display shows single and double digits. For example, if the digital display shows "2.0", the EXV open angle is 120×4=480p.
38	EXV open angle for B indoor unit	
39	EXV open angle for C indoor unit	
40	EXV open angle for D indoor unit	
41	EXV open angle for E indoor unit	

42	Frequency limit symbol	Bit7	Frequency limit caused by IGBT radiator	<p>The display value is a hexadecimal number. For example, the digital display show 2A, then Bit5=1, Bit3=1, and Bit1=1. This means that a frequency limit may be caused by T4, T3, or the current.</p>
		Bit6	Frequency limit caused by PFC	
		Bit5	Frequency limit caused by T4.	
		Bit4	Frequency limit caused by T2.	
		Bit3	Frequency limit caused by T3.	
		Bit2	Frequency limit caused by T5.	
		Bit1	Frequency limit caused by current	
		Bit0	Frequency limit caused by voltage	
43	T2B fault	00:No fault,01:T2B-A fault, ,02:T2B-B fault ,03:T2B-C fault,04:T2B-D fault, 05:T2B-E fault, 06:T2B-F fault(The display priority is A-B-C-D-E-F)		
44	Average value of T2	(Sum T2 value of all indoor units)/(number of indoor units in good connection)(The heating is the average value of T2, and the cooling is the average value of T2B)		
45	Outdoor unit fan motor state	Off: 0, Super ultra high speed:1, Super high speed:2, High speed:3, Med speed: 4, Low speed: 5, Breeze:6, Super breeze: 7		
46	F indoor unit capacity	Reserved		
47	F indoor unit capacity demand code			
48	F indoor unit evaporator outlet temperature (T2BF)			
49	F indoor unit room temperature (T1F)			
50	F indoor unit evaporator temperature (T2F)			
51	EXV open angle for F indoor unit			
52	Reason of stop			

Automatic wiring/piping correction function

Press the “check switch” on the outdoor unit PCB board 5 seconds until LED display “CE”, which mean this function is working, Approximately 5-10 minutes after the switch is pressed, the “CE” disappear the wiring/piping error will be corrected, and wiring/piping is properly connected.

4. Error Diagnosis and Troubleshooting Without Error Code



WARNING

Be sure to turn off unit before any maintenance to prevent damage or injury.

4.1 Remote maintenance

SUGGESTION: When troubles occur, please check the following points with customers before field maintenance.

No.	Problem	Solution
1	Unit will not start	Page 190~191
2	The power switch is on but fans will not start	Page 190~191
3	The temperature on the display board cannot be set	Page 190~191
4	Unit is on but the wind is not cold(hot)	Page 190~191
5	Unit runs, but shortly stops	Page 190~191
6	The unit starts up and stops frequently	Page 190~191
7	Unit runs continuously but insufficient cooling(heating)	Page 190~191
8	Cool can not change to heat	Page 190~191
9	Unit is noisy	Page 190~191

4.2 Field maintenance

	Problem	Solution
1	Unit will not start	Page 192~193
2	Compressor will not start but fans run	Page 192~193
3	Compressor and condenser (outdoor) fan will not start	Page 192~193
4	Evaporator (indoor) fan will not start	Page 192~193
5	Condenser (Outdoor) fan will not start	Page 192~193
6	Unit runs, but shortly stops	Page 192~193
7	Compressor short-cycles due to overload	Page 192~193
8	High discharge pressure	Page 192~193
9	Low discharge pressure	Page 192~193
10	High suction pressure	Page 192~193
11	Low suction pressure	Page 192~193
12	Unit runs continuously but insufficient cooling	Page 192~193
13	Too cool	Page 192~193
14	Compressor is noisy	Page 192~193
15	Horizontal louver can not revolve	Page 192~193

1.Remote Maintenance	Electrical Circuit				Refrigerant Circuit															
Possible causes of trouble	Power failure																			
	The main power tripped																			
	Loose connections																			
	Faulty transformer																			
	The voltage is too high or too low																			
	The remote control is powered off																			
	Broken remote control																			
	Dirty air filter																			
	Dirty condenser fins																			
	The setting temperature is higher/lower than the room's(cooling/heating)																			
	The ambient temperature is too high/low when the mode is cooling/heating																			
Fan mode																				
SILENCE function is activated(optional function)																				
Frosting and defrosting frequently																				
Unit will not start	☆	☆	☆	☆																
The power switch is on but fans will not start			☆	☆	☆															
The temperature on the display board cannot be set						☆	☆													
Unit is on but the wind is not cold(hot)										☆	☆	☆								
Unit runs, but shortly stops					☆					☆	☆									
The unit starts up and stops frequently					☆						☆	☆						☆		
Unit runs continuously but insufficient cooling/heating)								☆	☆	☆	☆				☆					
Cool can not change to heat																				
Unit is noisy																				
Test method / remedy	Test voltage																			
	Close the power switch																			
	Inspect connections - tighten																			
	Change the transformer																			
	Test voltage																			
	Replace the battery of the remote control																			
	Replace the remote control																			
	Clean or replace																			
	Clean																			
	Adjust the setting temperature																			
	Turn the AC later																			
Adjust to cool mode																				
Turn off SILENCE function.																				
Turn the AC later																				

1.Remote Maintenance	Others					
Possible causes of trouble	Heavy load condition	Loosen hold down bolts and / or screws	Bad airproof	The air inlet or outlet of either unit is blocked	Interference from cell phone towers and remote boosters	Shipping plates remain attached
	Unit will not start					
	The power switch is on but fans will not start				☆	
	The temperature on the display board cannot be set					
	Unit is on but the wind is not cold(hot)					
	Unit runs, but shortly stops					
The unit starts up and stops frequently				☆		
Unit runs continuously but insufficient cooling(heating)	☆		☆	☆		
Cool can not change to heat						
Unit is noisy		☆			☆	
Test method / remedy	Check heat load	Tighten bolts or screws	Close all the windows and doors	Remove the obstacles	Reconnect the power or press ON/OFF button on remote control to restart operation	Remove them

2.Field Maintenance	Refrigerant Circuit																Others							
Possible causes of trouble	Compressor stuck	Shortage of refrigerant	Restricted liquid line	Dirty air filter	Dirty evaporator coil	Insufficient air through evaporator coil	Overcharge of refrigerant	Dirty or partially blocked condenser	Air or incompressible gas in refrigerant cycle	Short cycling of condensing air	High temperature condensing medium	Insufficient condensing medium	Broken compressor internal parts	Inefficient compressor	Expansion valve obstructed	Expansion valve or capillary tube closed completely	Leaking power element on expansion valve	Poor installation of feeler bulb	Heavy load condition	Loosen hold down bolts and / or screws	Shipping plates remain attached	Poor choices of capacity	Contact of piping with other piping or external plate	
Unit will not start																								
Compressor will not start but fans run	☆																							
Compressor and condenser (outdoor) fan will not start																								
Evaporator (indoor) fan will not start																								
Condenser (Outdoor) fan will not start																								
Unit runs, but shortly stops		☆	☆				☆	☆								☆	☆							
Compressor short-cycles due to overload		☆					☆	☆																
High discharge pressure							☆	☆	☆	☆	☆	☆												
Low discharge pressure		☆												☆										
High suction pressure							☆							☆				☆	☆					
Low suction pressure		☆	☆	☆	☆	☆								☆	☆	☆								
Unit runs continuously but insufficient cooling		☆	☆	☆	☆	☆		☆	☆	☆				☆					☆			☆		
Too cool																								
Compressor is noisy							☆						☆							☆	☆		☆	
Horizontal louver can not revolve																								
Test method / remedy	Replace the compressor	Leak test	Replace restricted part	Clean or replace	Clean coil	Check fan	Change charged refrigerant volume	Clean condenser or remove obstacle	Purge, evacuate and recharge	Remove obstruction to air flow	Remove obstruction in air or water flow	Remove obstruction in air or water flow	Replace compressor	Test compressor efficiency	Replace valve	Replace valve	Replace valve	Fix feeler bulb	Check heat load	Tighten bolts or screws	Remove them	Choose AC of lager capacity or add the number of AC	Rectify piping so as not to contact each other or with external plate	

2.Field Maintenance	Electrical Circuit														
Possible causes of trouble	Power failure	Blown fuse or varistor	Loose connections	Shorted or broken wires	Safety device opens	Faulty thermostat / room temperature sensor	Wrong setting place of temperature sensor	Faulty transformer	Shorted or open capacitor	Faulty magnetic contactor for compressor	Faulty magnetic contactor for fan	Low voltage	Faulty stepping motor	Shorted or grounded compressor	Shorted or grounded fan motor
Unit will not start	☆	☆	☆	☆	☆			☆							
Compressor will not start but fans run				☆		☆			☆	☆				☆	
Compressor and condenser (outdoor) fan will not start				☆		☆				☆					
Evaporator (indoor) fan will not start				☆					☆		☆				☆
Condenser (Outdoor) fan will not start				☆		☆			☆		☆				☆
Unit runs, but shortly stops										☆		☆			
Compressor short-cycles due to overload										☆		☆			
High discharge pressure															
Low discharge pressure															
High suction pressure															
Low suction pressure															
Unit runs continuously but insufficient cooling															
Too cool						☆	☆								
Compressor is noisy															
Horizontal louver can not revolve			☆	☆									☆		
Test method / remedy	Test voltage	Inspect fuse type & size	Inspect connections - tighten	Test circuits with tester	Test continuity of safety device	Test continuity of thermostat / sensor & wiring Place the temperature sensor at the central of the air inlet grille.	Check control circuit with tester	Check capacitor with tester	Test continuity of coil & contacts	Test continuity of coil & contacts	Test voltage	Replace the stepping motor	Check resistance with multimeter	Check resistance with multimeter	

5. Troubleshooting by Error Code

TS01-IDU: Indoor EEPROM parameter error diagnosis and solution

Description: Indoor PCB main chip does not receive feedback from EEPROM chip.

Recommended parts to prepare:

- Indoor PCB

Troubleshooting and repair:

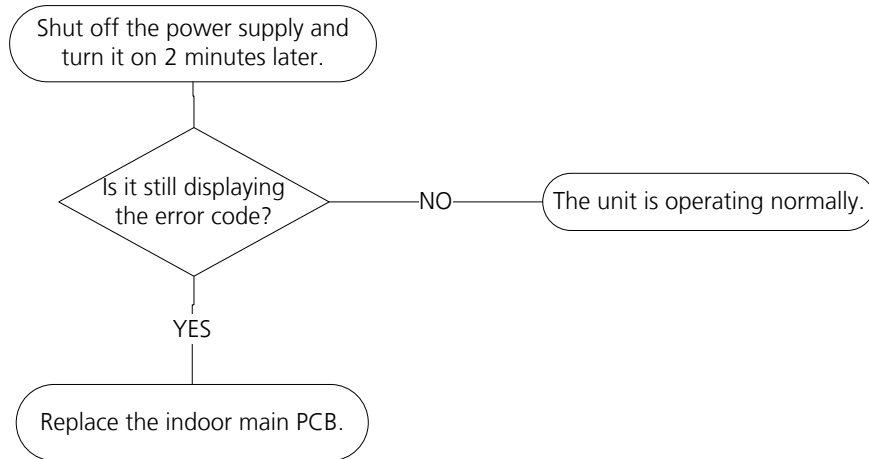

Remarks:

EEPROM: A read-only memory whose contents can be erased and reprogrammed using a pulsed voltage.

The location of the EEPROM chip on the indoor PCB is shown in the following image:

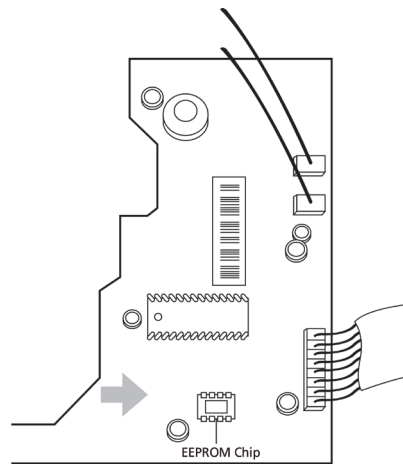

Note: This pictures are only for reference, actual appearance may vary.

TS01-ODU: Outdoor EEPROM parameter error or Compressor driven chip EEPROM parameter error diagnosis and solution

Description: Outdoor PCB main chip does not receive feedback from EEPROM chip or compressor driven chip.

Recommended parts to prepare:

- Outdoor PCB

Troubleshooting and repair:

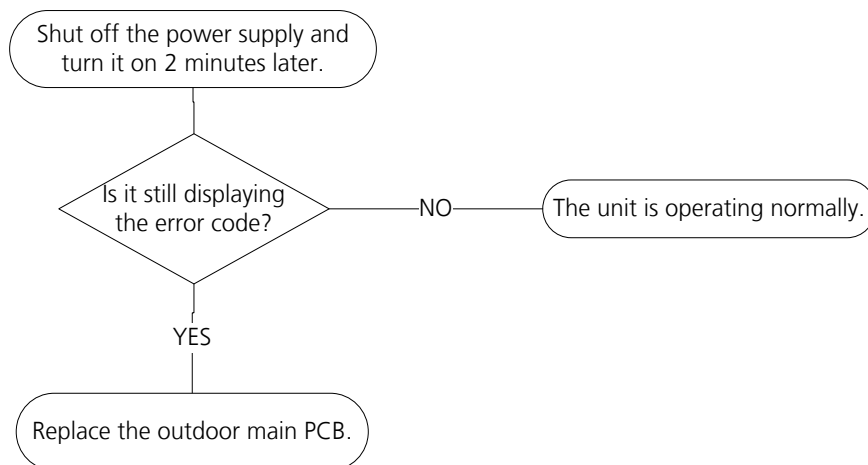

Remarks:

EEPROM: A read-only memory whose contents can be erased and reprogrammed using a pulsed voltage.

The location of the EEPROM chip on the outdoor PCB is shown in the following image:

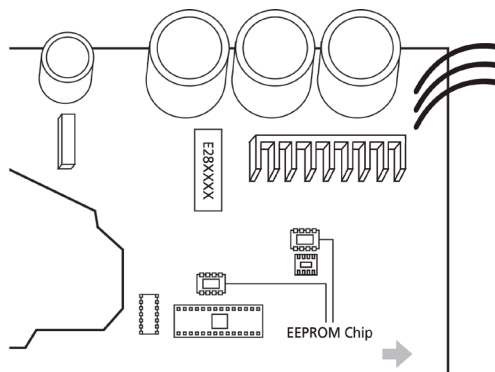

Note: For certain models, outdoor PCB could not be removed separately. In this case, the outdoor electric control box should be replaced as a whole. This pictures are only for reference, actual appearance may vary.

TS02-M: Indoor and outdoor units communication error diagnosis and solution

Description: Indoor unit can not communicate with outdoor unit

Recommended parts to prepare:

- Indoor PCB
- Outdoor PCB
- Short-circuited component

Troubleshooting and repair:

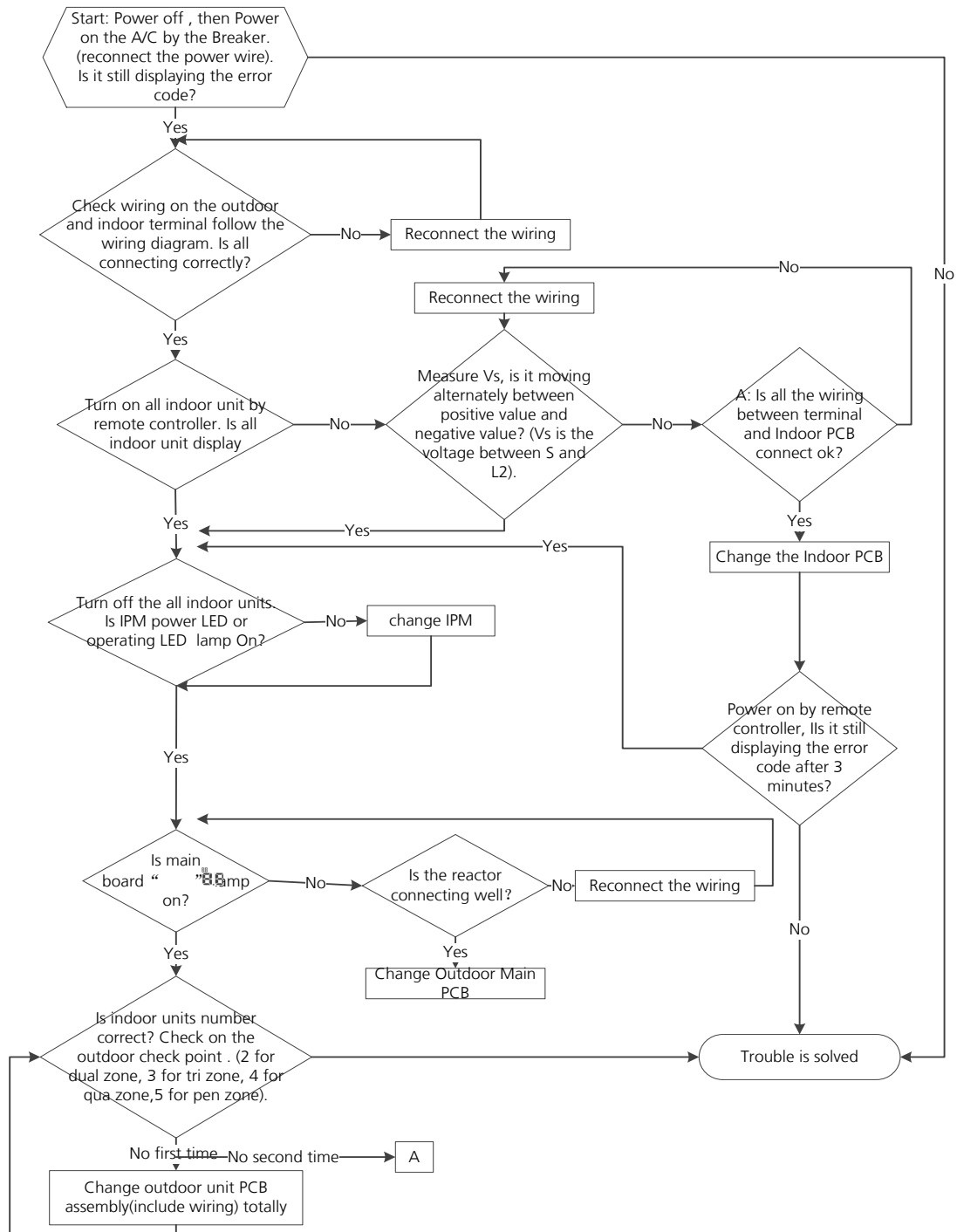

Remarks:

- Use a multimeter to test the DC voltage between 2 port(or S or L2 port) and 3 port(or N or S port) of outdoor unit. The red pin of multimeter connects with 2 port(or S or L2 port) while the black pin is for 3 port(or N or S port).
- When AC is normal running, the voltage is moving alternately as positive values and negative values
- If the outdoor unit has malfunction, the voltage has always been the positive value.
- While if the indoor unit has malfunction, the voltage has always been a certain value.

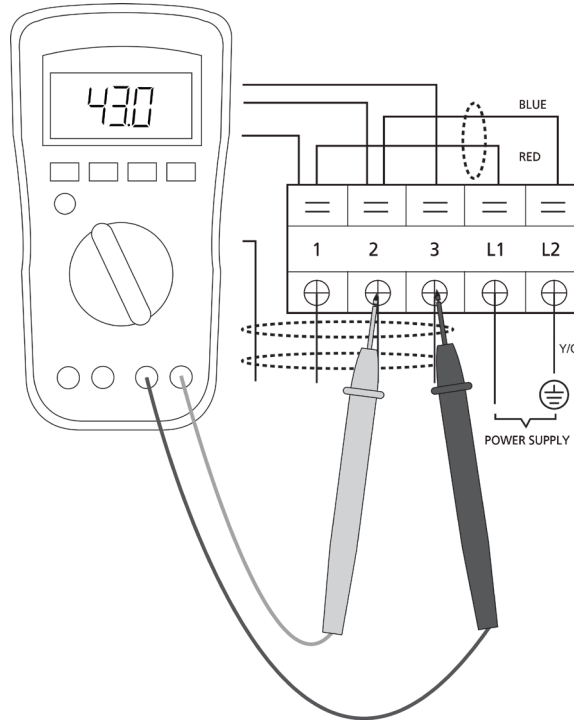

**S and N
or
L2 and S
or
2 and 3**

- Use a multimeter to test the resistance of the reactor which does not connect with capacitor.
- The normal value should be around zero ohm. Otherwise, the reactor must have malfunction.

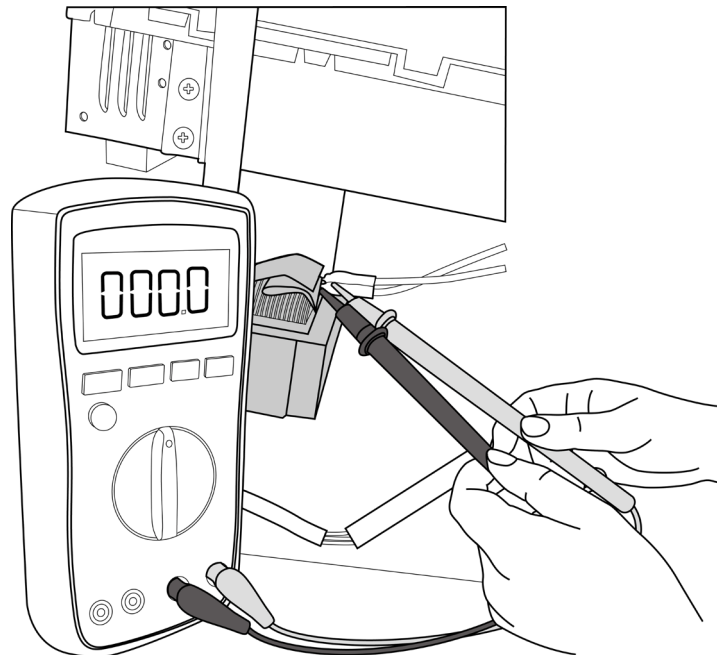

Note: The picture and the value are only for reference, actual condition and specific value may vary.

TS04-L-IDU: The Indoor fan speed is operating outside of normal range diagnosis and solution)

Description: When indoor fan speed keeps too low or too high for a certain time, the LED displays the failure code and the AC turns off.

Recommended parts to prepare:

- Connection wires
- Fan assembly
- Fan motor
- Indoor main PCB

Troubleshooting and repair:

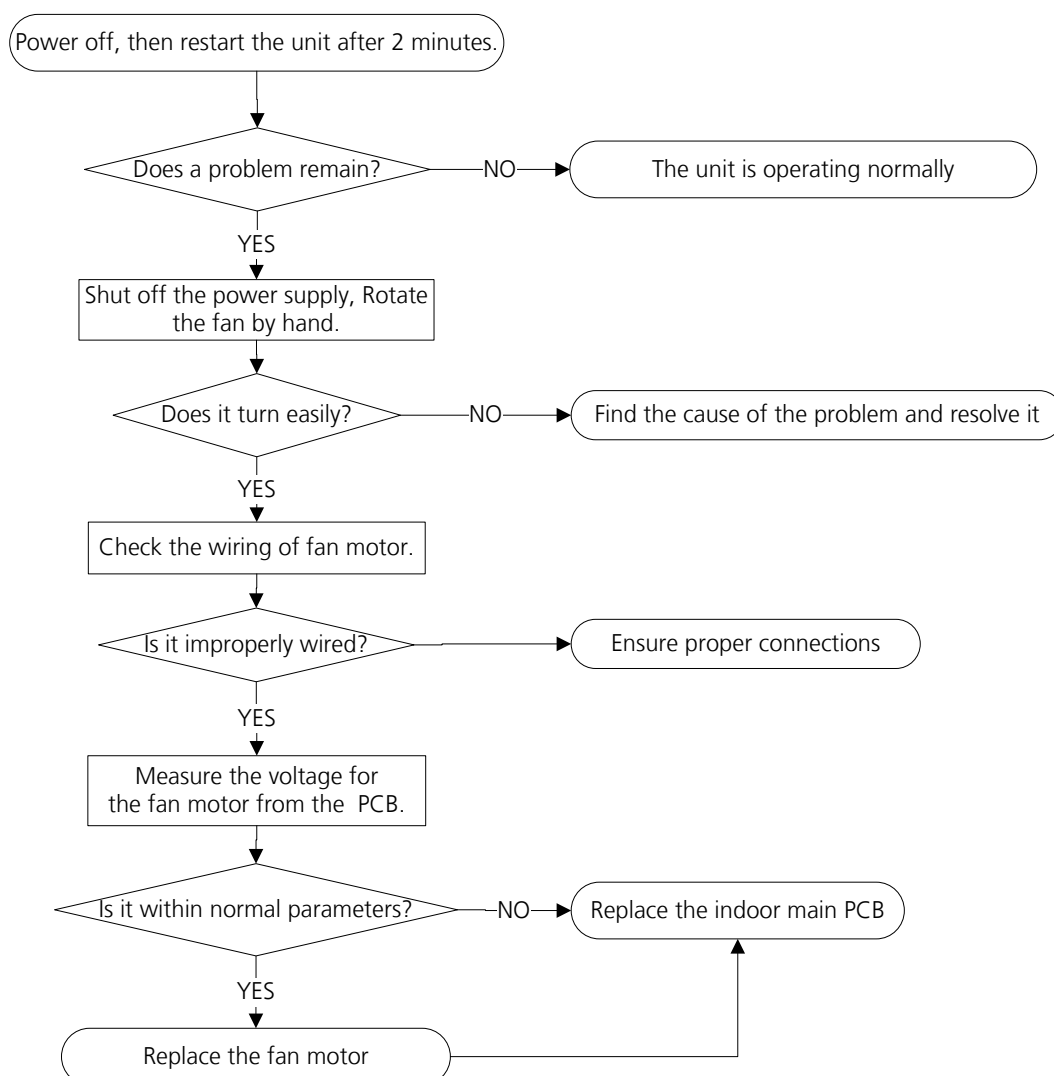

Index:

1. DC Fan Motor(control chip is in fan motor)

some models:

Power on and when the unit is in standby, measure the voltage of pin1-pin3, pin4-pin3 in fan motor connector. If the value of the voltage is not in the range showing in below table, the PCB must has problems and need to be replaced.

- DC motor voltage input and output:

No.	Color	Signal	Voltage
1	Red	Vs/Vm	192V~380V
2	---	---	---
3	Black	GND	0V
4	White	Vcc	13.5-16.5V
5	Yellow	Vsp	0~6.5V
6	Blue	FG	13.5-16.5V

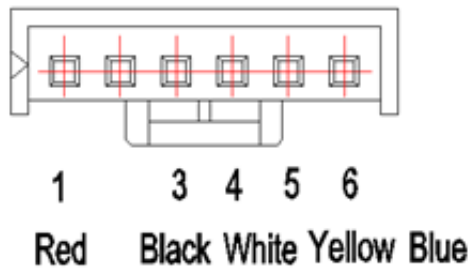

some models:

Power on and when the unit is in standby, measure the voltage of pin1&pin2 of CN15, pin3 of CN34 in fan motor connector. If the value of the voltage is not in the range showing in below table, the PCB must has problems and need to be replaced.

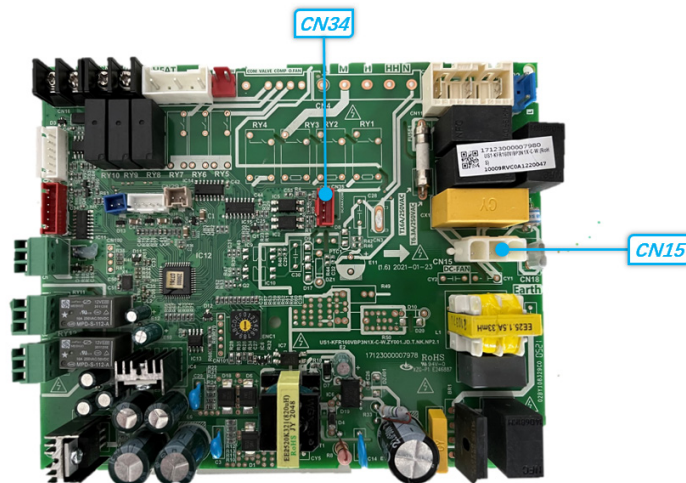

CN34 NO.	Color	Signal	Voltage
1	--	--	
2	Black	GND	
3	Orange	PWM	5-12VDC
4	Blue	FG	

CN15 NO.	Color	Signal	Voltage
1	Yellow		208/230VAC
2	Black		208/230VAC
3	Yellow-Green	GND	

2. Indoor DC Fan IPM Board (Duct and Ceiling-floor Unit)

Power on and when the unit is in standby, measure the voltage of CON1, pin1-pin2 and pin3-pin2 of CN1 in DC motor driver board. If the value of the voltage is not in the range showing in below tables, the indoor main PCB must have problems and need to be replaced.

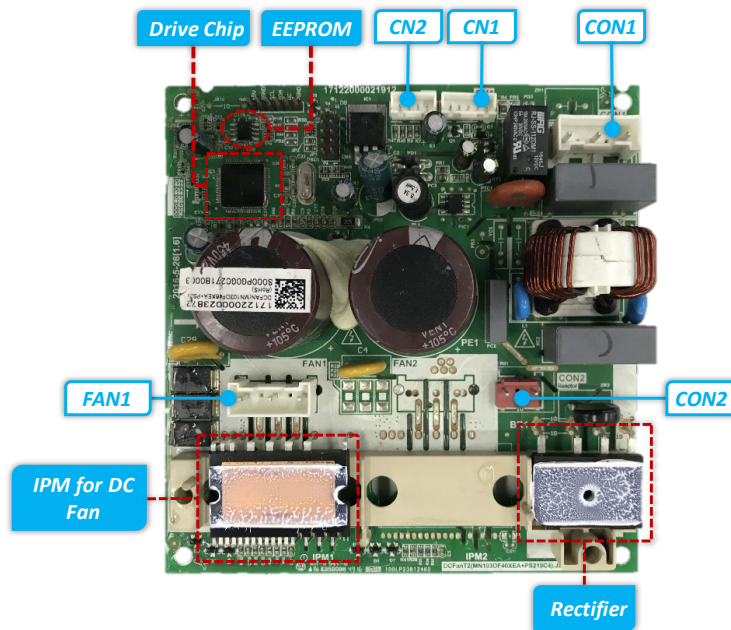

Port	Description	Parameter	Remark
CON1	Power input for the PCB	230V/AC	
CN1	Communication with main PCB	DC	
CN2	Test port	5V/DC	For debugging board
CN23	UVW output for DC fan motor		
CON2	Ports for reactor		

CN1 Communication with main PCB

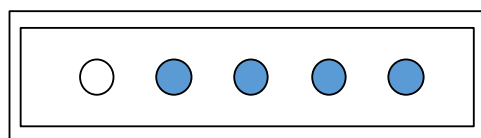

5 4 3 2 1

NO.	Signal	Voltage
1	Vcc	+15V
2	GND	
3	TXD	0~6V
4	RXD	0~15V
5	--	--

TS04-ODU: The outdoor fan speed is operating outside of normal range diagnosis and solution)

Description: When outdoor fan speed keeps too low or too high for a certain time, the LED displays the failure code and the AC turns off.

Recommended parts to prepare:

- Connection wires
- Fan assembly
- Fan motor
- Outdoor main PCB

Troubleshooting and repair:

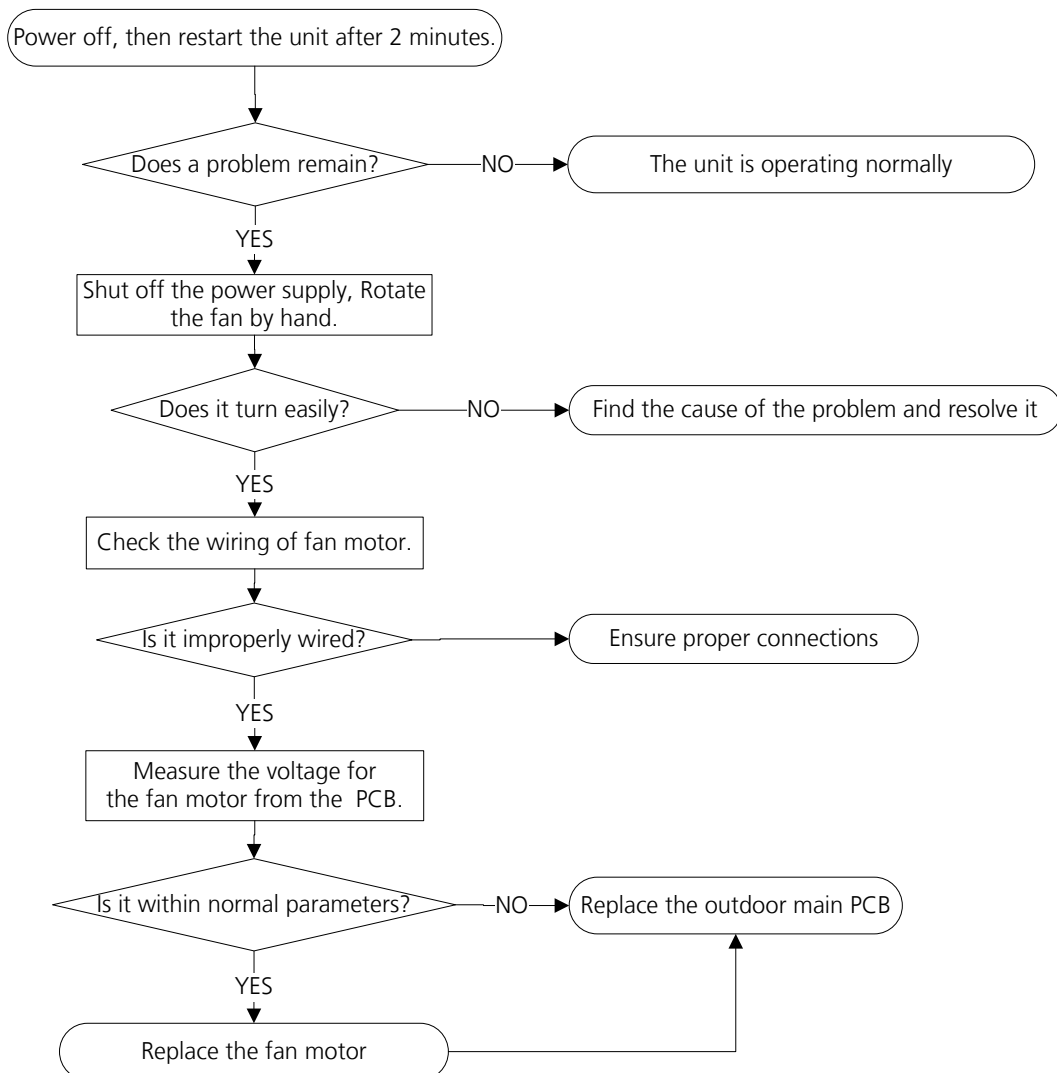

Index:

1. Outdoor DC Fan Motor (control chip is in outdoor PCB)

Release the UVW connector. Measure the resistance of U-V, U-W, V-W. If the resistance is not equal to each other, the fan motor must have problems and need to be replaced. otherwise the PCB must have problems and need to be replaced.

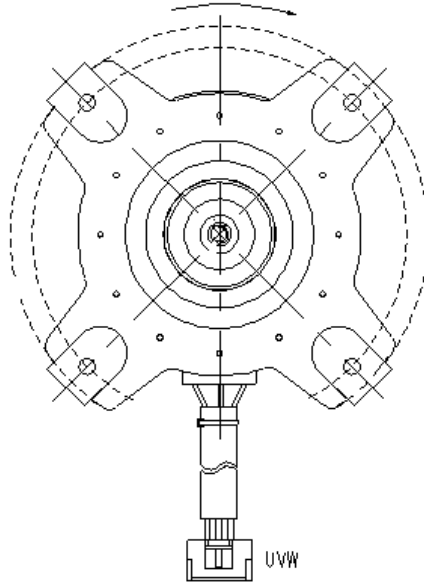

2. DC Fan Motor(control chip is in fan motor, single fan)

Power on and when the unit is in standby, measure the voltage of pin1-pin3, pin4-pin3 in fan motor connector. If the value of the voltage is not in the range showing in below table, the PCB must have problems and need to be replaced.

No.	Color	Signal	Voltage
1	Red	Vs/Vm	192V~380V
2	---	---	---
3	Black	GND	0V
4	White	Vcc	13.5-16.5V
5	Yellow	Vsp	0~6.5V
6	Blue	FG	13.5-16.5V

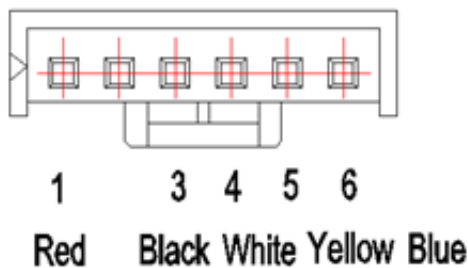

3. Outdoor DC Fan IPM Board(for some double fan models)

Power on and when the unit is in standby, measure the voltage of CON1, pin1-pin2 and pin3-pin2 of CN1 in DC motor driver board. If the value of the voltage is not in the range showing in below tables, the outdoor main PCB must has problems and need to be replaced.

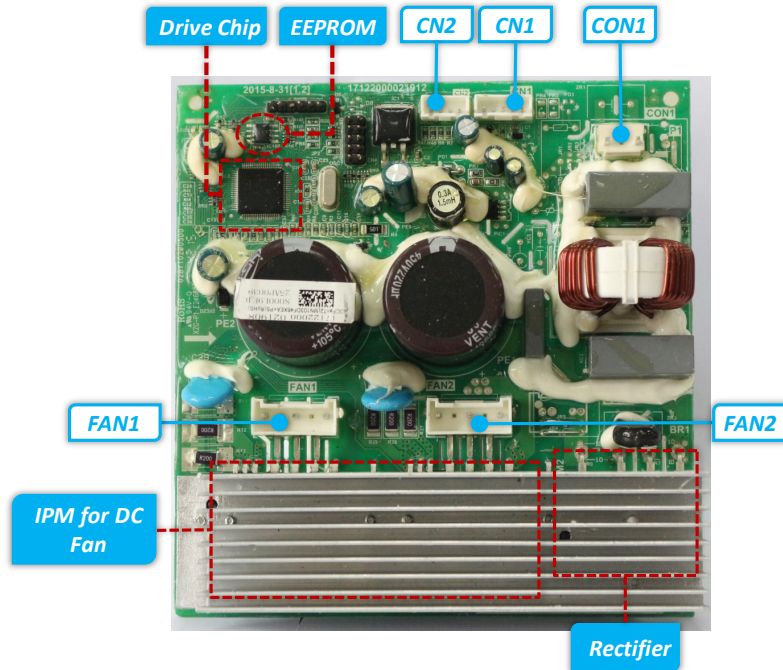

Part	Description	Parameter	Remark
CON1	Power input for the PCB	192-380V/DC	
CN1	Communication with main PCB	DC	
CN2	Test port	5V/DC	For debugging board
FAN1	UVW output for DC fan motor		
FAN2	UVW output for DC fan motor		

CN1 Communication with main PCB

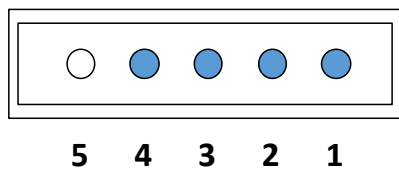

No.	Signal	Voltage
1	Vcc	13.5-16.5V
2	GND	0V
3	Vsp	0~6.5V
4	FG	13.5-16.5V
5	---	---

TS05-IDU: Open circuit or short circuit of indoor temperature sensor(T1, T2) diagnosis and solution

Description: If the sampling voltage is lower than 0.06V or higher than 4.94V, the LED displays the failure code.

Recommended parts to prepare:

- Connection wires
- Sensors
- Indoor main PCB

Troubleshooting and repair:

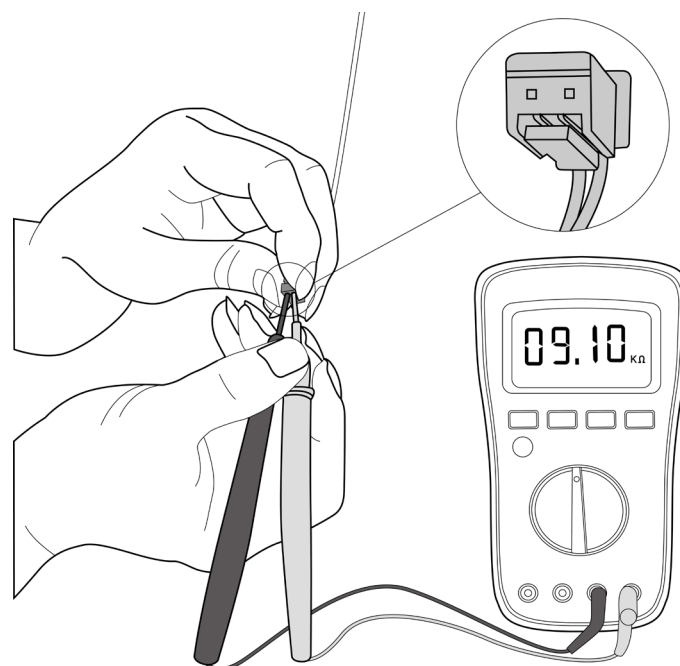
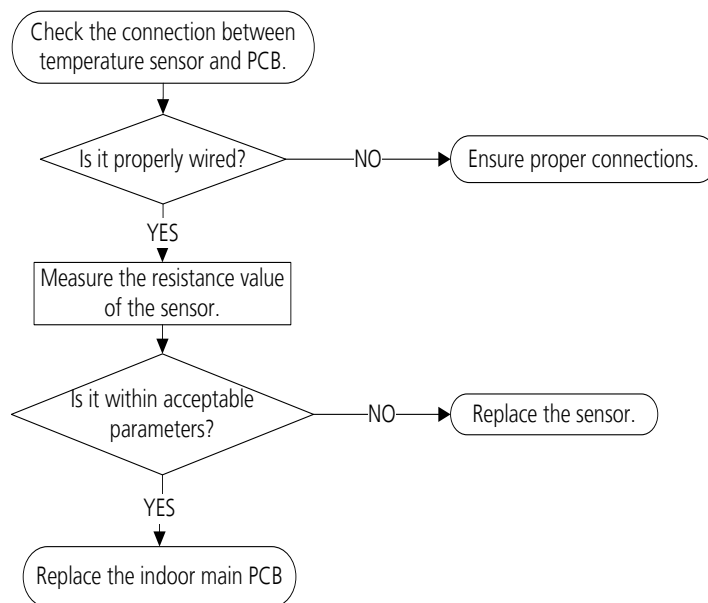

Note: The picture and the value are only for reference, actual condition and specific value may vary.

TS05-ODU: Open circuit or short circuit of outdoor temperature sensor(T3, T4, TP, T2B,TH) diagnosis and solution

Description: If the sampling voltage is lower than 0.06V or higher than 4.94V, the LED displays the failure code.

Recommended parts to prepare:

- Connection wires
- Sensors
- Outdoor main PCB

Troubleshooting and repair:

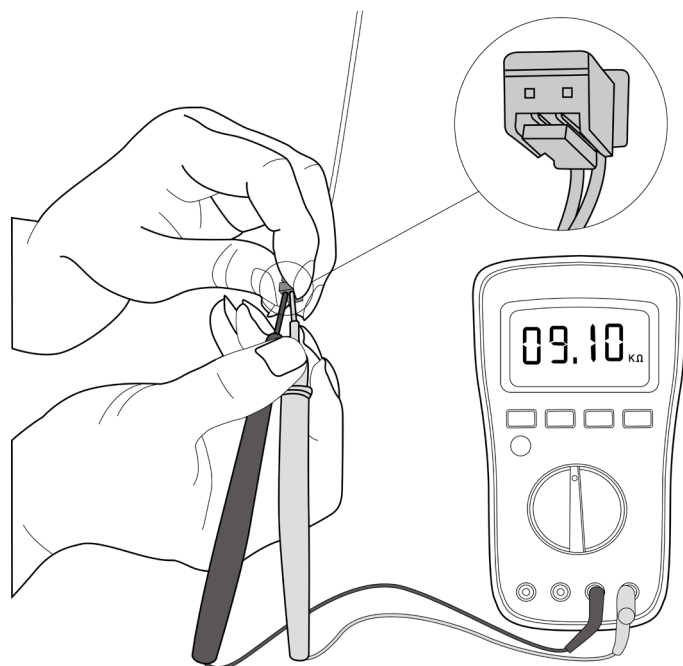
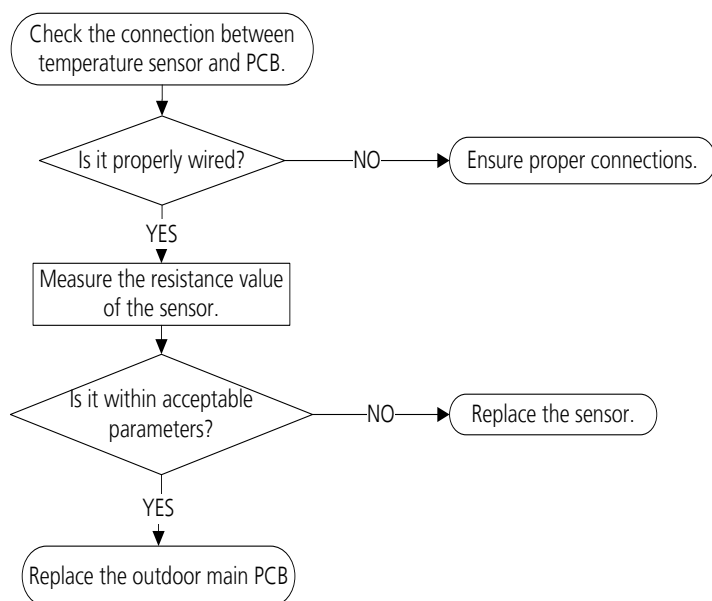

Note: For certain models, outdoor PCB could not be removed separately. In this case, the outdoor electric control box should be replaced as a whole. For certain models, outdoor unit uses combination sensor, T3,T4 and TP are the same of sensor. This picture and the value are only for reference, actual appearance and value may vary.

TS08-L-INV: Current overload protection diagnosis and solution

Description: An abnormal current rise is detected by checking the specified current detection circuit.

Recommended parts to prepare:

- Connection wires
- Rectifier
- PFC circuit or reactor
- Blocked refrigeration piping system
- Pressure switch
- Outdoor fan
- IPM module board
- Outdoor PCB

Troubleshooting and repair:



Note: For certain models, outdoor PCB could not be removed separately. In this case, the outdoor electric control box should be replaced as a whole.

Index:

1. Normal voltage of P and N

208-240V(1-phase,3-phase)		380-415V(3-phase)	
In standby			
around 310VDC		around 530VDC	
In operation			
With passive PFC module	With partial active PFC module	With fully active PFC module	/
>200VDC	>310VDC	>370VDC	>450VDC

2.Reactor Check

Measure the resistance and voltage (to ground) of the reactor. The normal resistance should be around 0.1 ohm. Otherwise, the reactor must have malfunction.

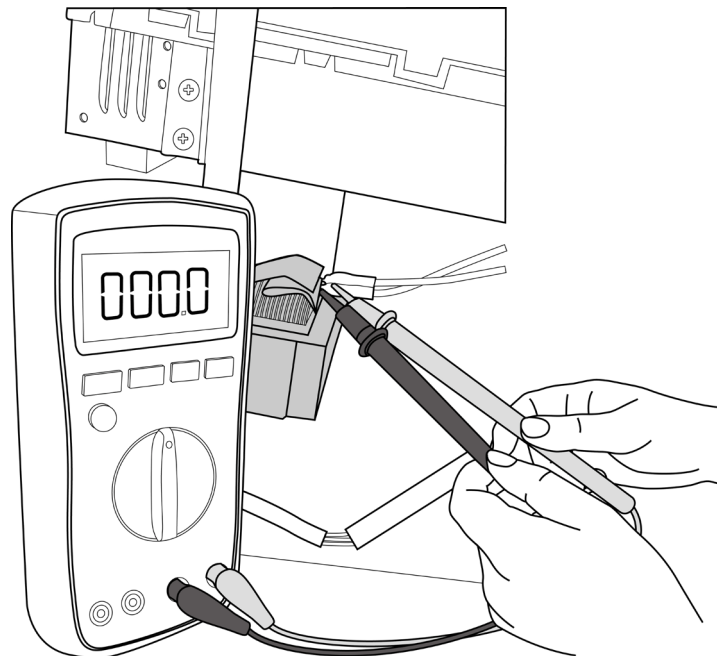

Note: The picture and the value are only for reference, actual condition and specific value may vary.

TS09-L: IPM malfunction or IGBT over-strong current protection or Inverter compressor drive error diagnosis and solution

Description: When the voltage signal the IPM sends to the compressor drive chip is abnormal, the LED displays the failure code and the AC turns off.

Or an abnormal inverter compressor drive is detected by a special detection circuit, including communication signal detection, voltage detection, compressor rotation speed signal detection and so on.

Recommended parts to prepare:

- Connection wires
- IPM module board
- Outdoor fan assembly
- Compressor
- Outdoor PCB
- High-voltage components
- PFC circuit or reactor

Troubleshooting and repair:

First, test the resistance between every two ports of U, V, the W of the IPM and P, N. If any of the results is 0 or close to 0, the IPM is defective. If not, follow the following procedure:

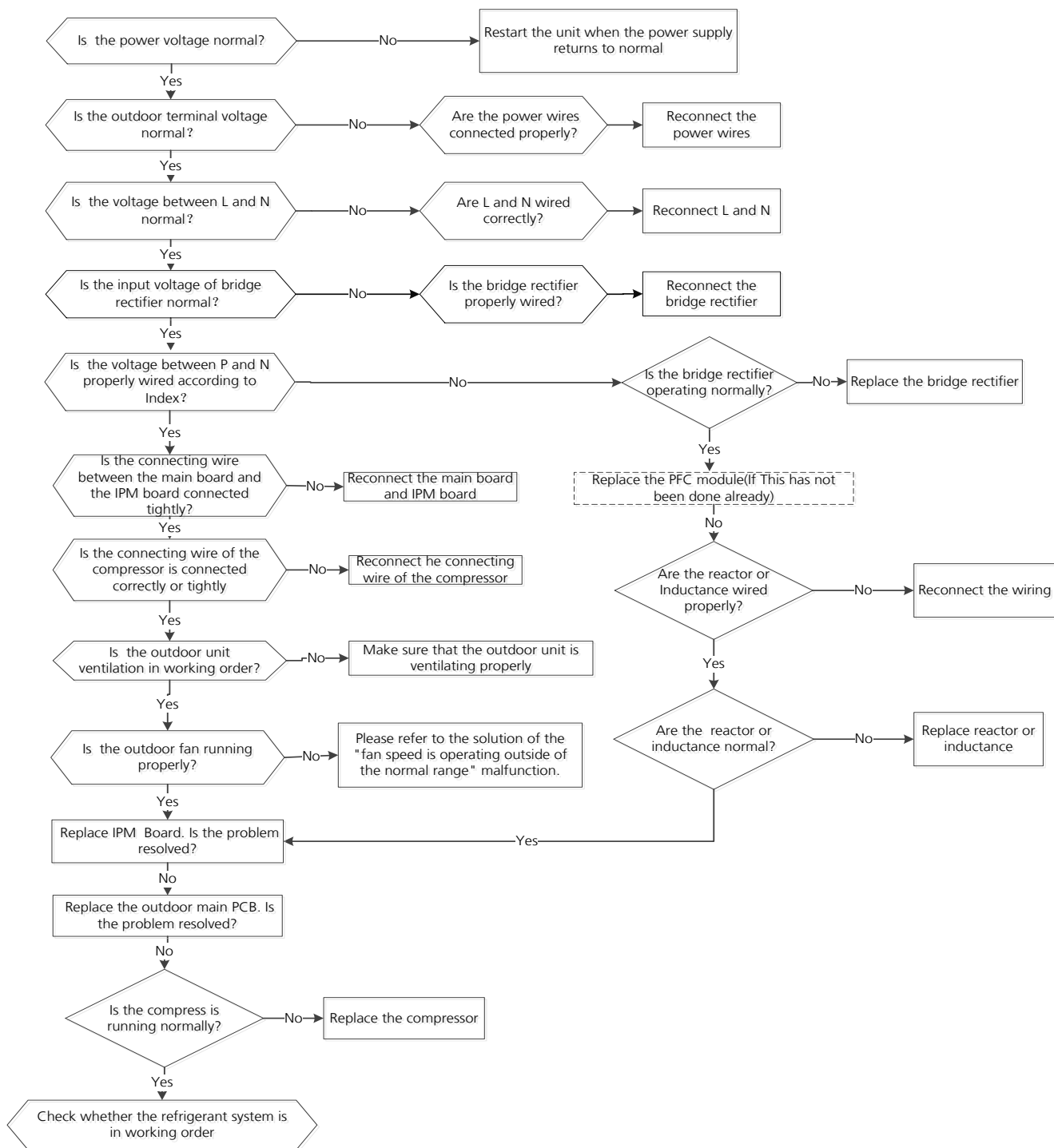

Note: For certain models, outdoor PCB could not be removed separately. In this case, the outdoor electric control box should be replaced as a whole.

Index:

1. IPM Continuity Check

⚠ WARNING

Electricity remains in capacitors even when the power supply is off. Ensure the capacitors are fully discharged before troubleshooting.

1. Turn off outdoor unit and disconnect power supply.
2. Discharge electrolytic capacitors and ensure all energy-storage unit has been discharged.
3. Disassemble outdoor PCB or disassemble IPM board.
4. Measure the resistance value between P and U(V, W, N); U(V, W) and N.

Digital tester		Resistance value	Digital tester		Resistance value
(+)Red	(-)Black		(+)Red	(-)Black	
P	N	∞ (Several MΩ)	U	N	∞ (Several MΩ)
	U		V		
	V		W		
	W		-		

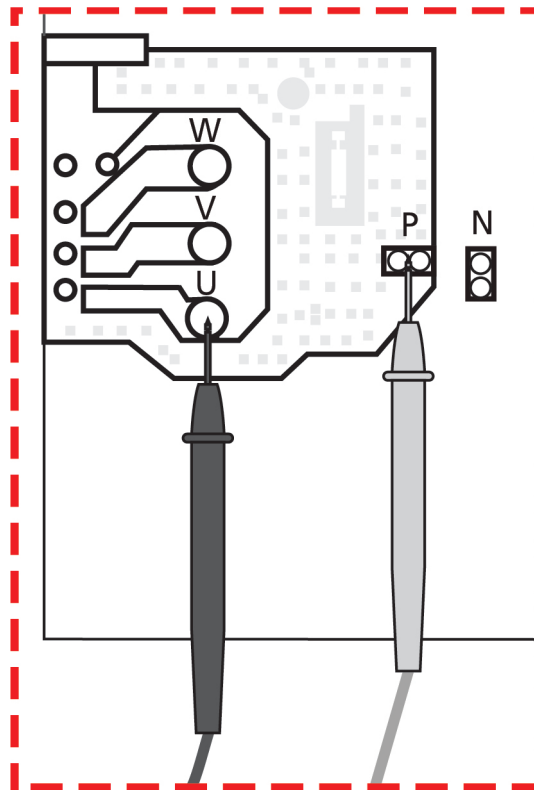

2. Normal voltage of P and N

208-240V(1-phase,3-phase)	380-415V(3-phase)
---------------------------	-------------------

In standby			
around 310VDC			around 530VDC
In operation			
With passive PFC module	With partial active PFC module	With fully active PFC module	/
>200VDC	>310VDC	>370VDC	>450VDC

3. Reactor Check

Measure the resistance and voltage (to ground) of the reactor. The normal resistance should be around 0.1 ohm. Otherwise, the reactor must have malfunction.

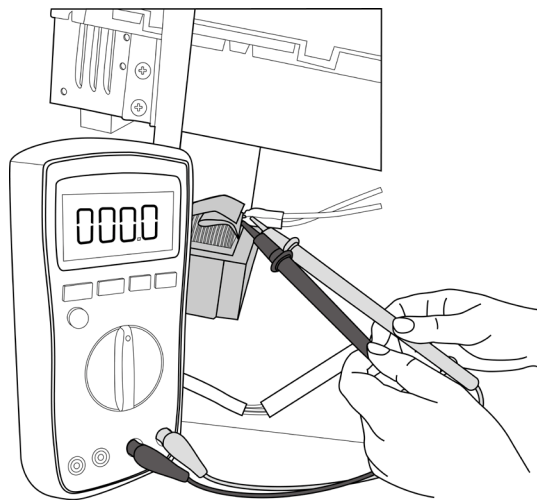

4. Compressor check

Disconnect the compressor and check the resistance between U-V, V-W and U-W, and all 3 values should be equal. If not, the compressor is faulty and should be replaced.

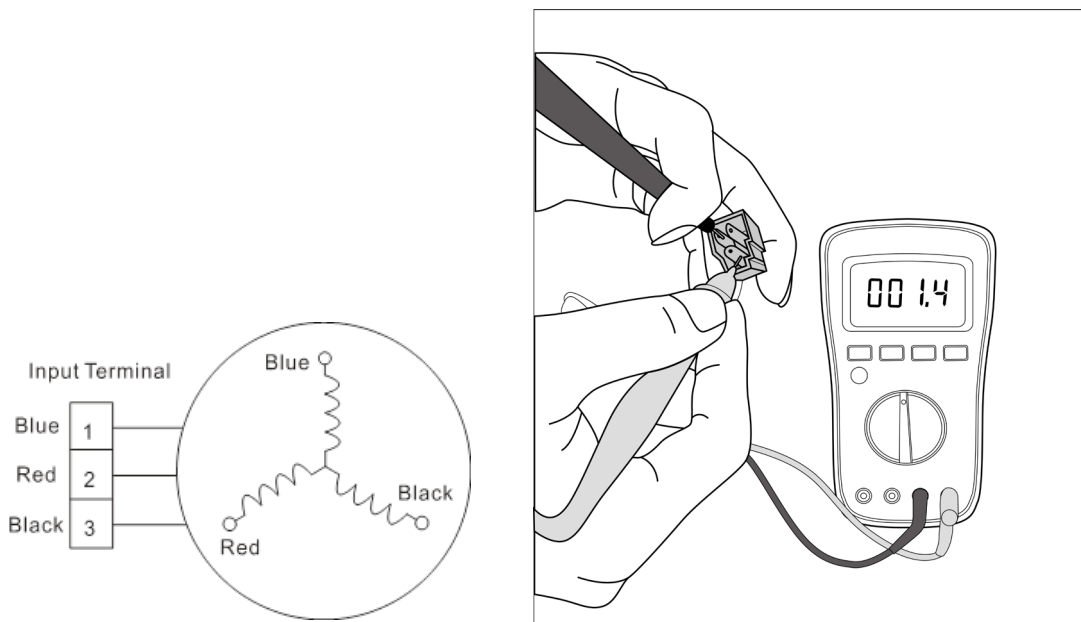

Note: The picture and the value are only for reference, actual condition and specific value may vary.

TS10-L: Over voltage or too low voltage protection diagnosis and solution

Description: Abnormal increases or decreases in voltage are detected by checking the specified voltage detection circuit.

Recommended parts to prepare:

- Power supply wires
- IPM module board
- PCB
- Reactor

Troubleshooting and repair:

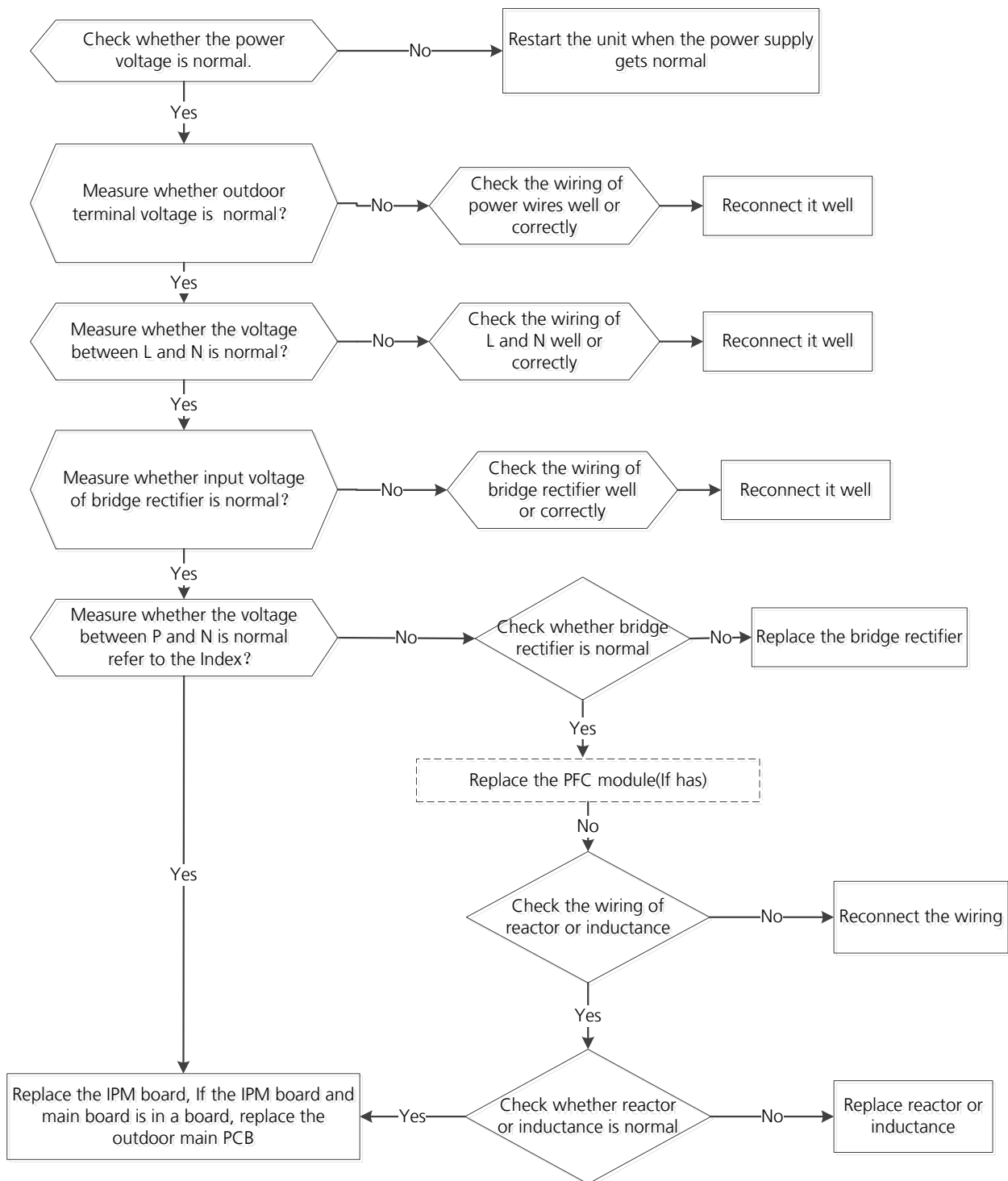

Note: For certain models, outdoor PCB could not be removed separately. In this case, the outdoor electric control box should be replaced as a whole.

Index:

1. Normal voltage of P and N

208-240V(1-phase,3-phase)		380-415V(3-phase)	
In standby			
around 310VDC		around 530VDC	
In operation			
With passive PFC module	With partial active PFC module	With fully active PFC module	/
>200VDC	>310VDC	>370VDC	>450VDC

2. Reactor Check

Measure the resistance and voltage (to ground) of the reactor. The normal resistance should be around 0.1 ohm. Otherwise, the reactor must have malfunction.

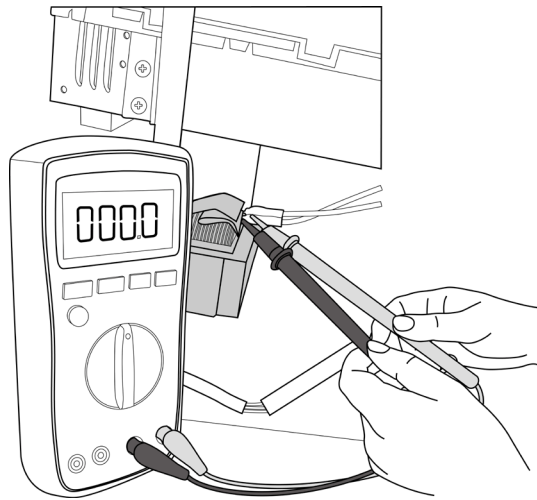

Note: The picture and the value are only for reference, actual condition and specific value may vary.

TS11-L: Top temperature protection of compressor diagnosis and solution

Description: If the sampling voltage is not 5V, the LED will display the failure.

Recommended parts to prepare:

- Connection wires
- Outdoor PCB
- Over load protector

Troubleshooting and repair:

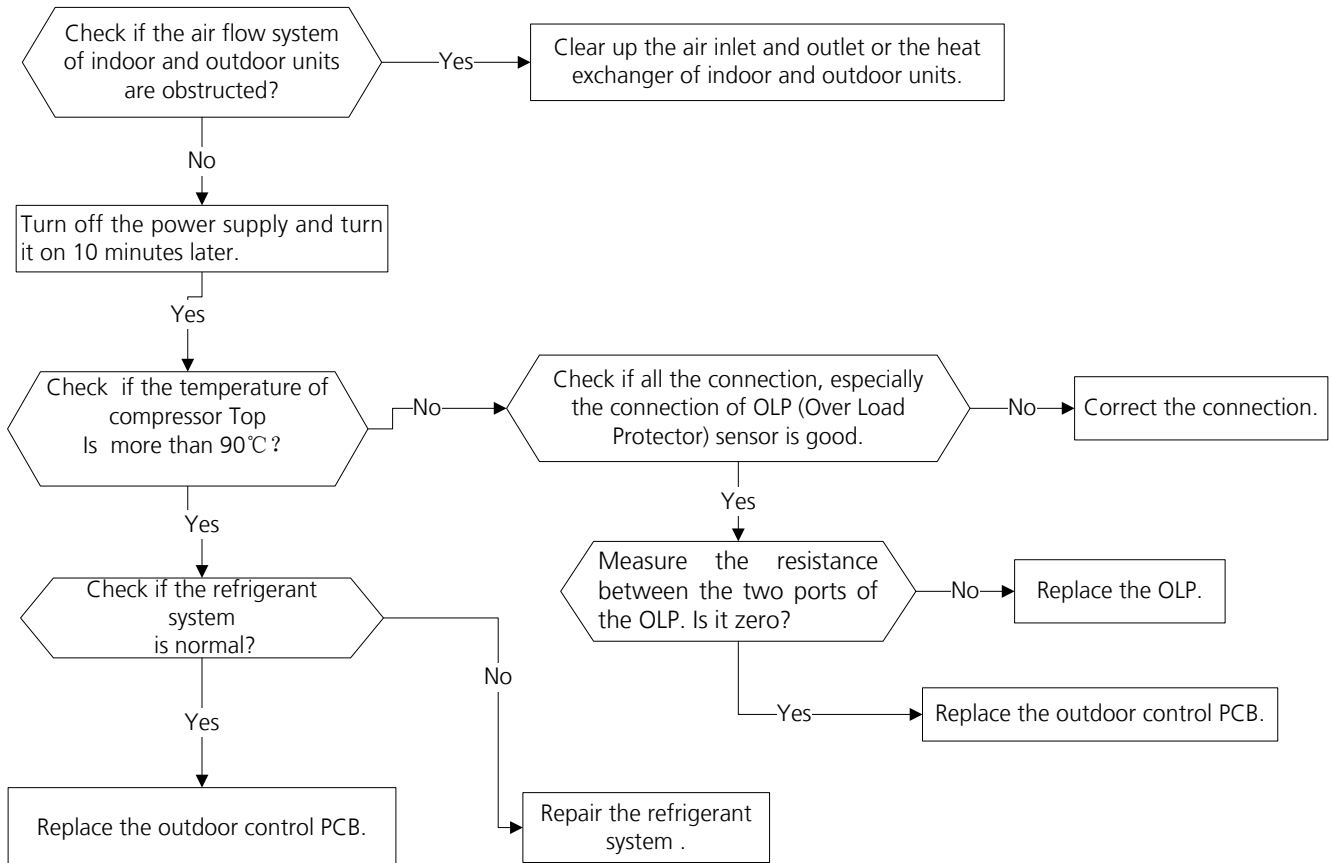

TS14: Indoor units mode conflict (match with multi outdoor unit)

Description: The indoor units cannot work cooling mode and heating at same time. Heating mode has a priority.

- Suppose Indoor unit A working in cooling mode or fan mode, and indoor unit B is set to heating mode, then A will change to off and B will work in heating mode.
- Suppose Indoor unit A working in heating mode, and indoor unit B is set to cooling mode or fan mode, then B will change to stand by and A will be no change.

	Cooling mode	Heating Mode	Fan	Off
Cooling mode	No	Yes	No	No
Heating Mode	Yes	No	Yes	No
Fan	No	Yes	No	No
Off	No	No	No	No

Note:

No: No mode conflict

Yes: Mode conflict

TS15: Water-Level Alarm Malfunction Diagnosis and Solution

Description: If the sampling voltage is not 5V, the LED displays the failure code.

Recommended parts to prepare:

- Connection wires
- Water-level switch
- Water pump
- Indoor PCB

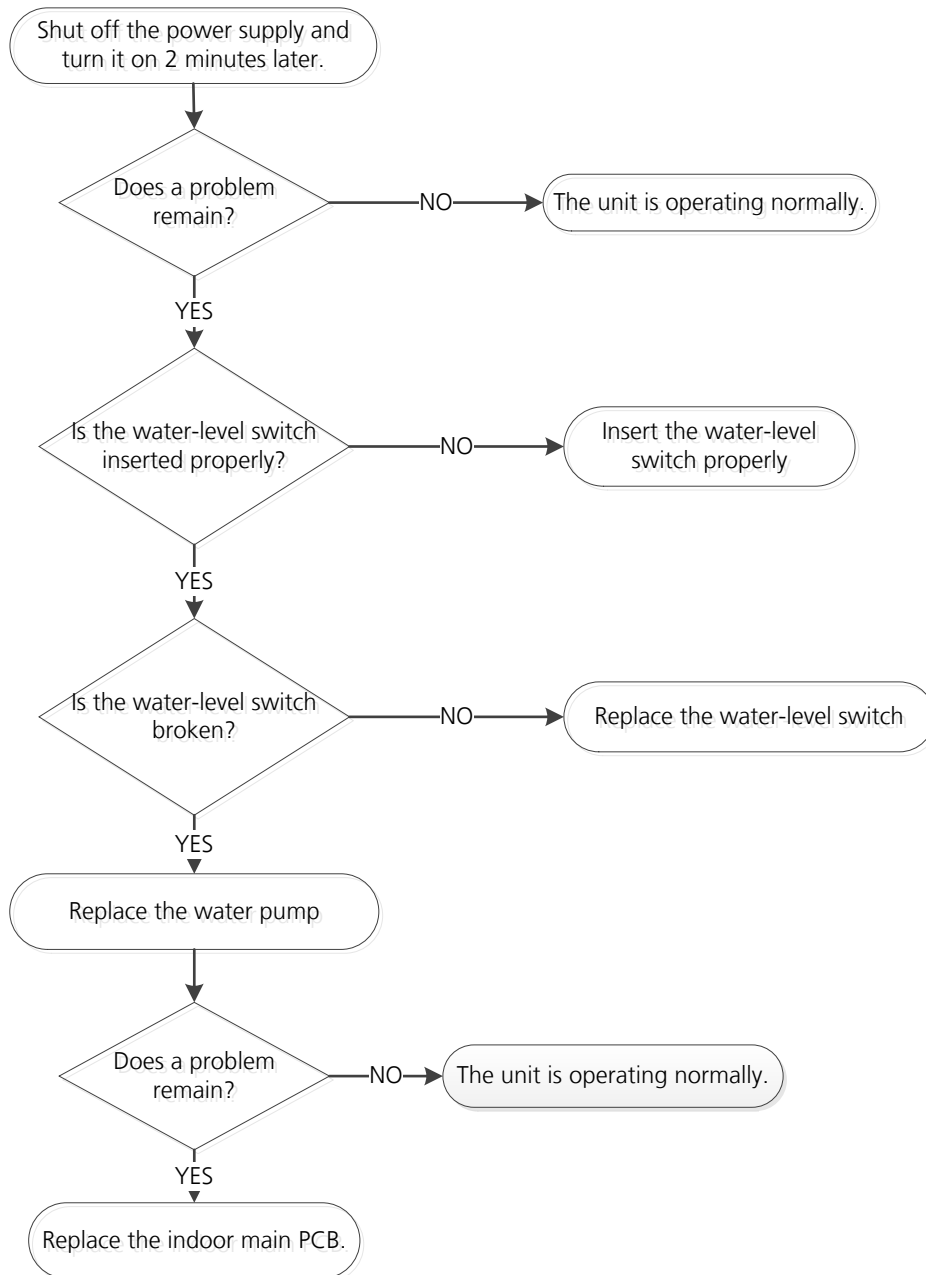

TS23: Communication error between indoor two chips diagnosis and solution

Description: Indoor PCB main chip does not receive feedback from another chip.

Recommended parts to prepare:

- Indoor PCB

Troubleshooting and repair:

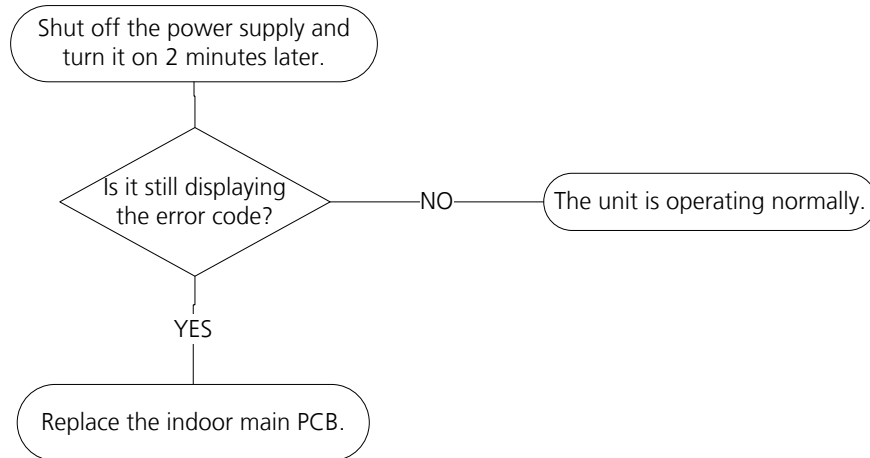

TS13-INV: Low pressure protection diagnosis and solution

Description: Outdoor pressure switch cut off the system because low pressure is lower than 0.13 MPa, the LED displays the failure code.

Recommended parts to prepare:

- Connection wires
- Outdoor PCB
- Low pressure protector
- Refrigerant

Troubleshooting and repair:

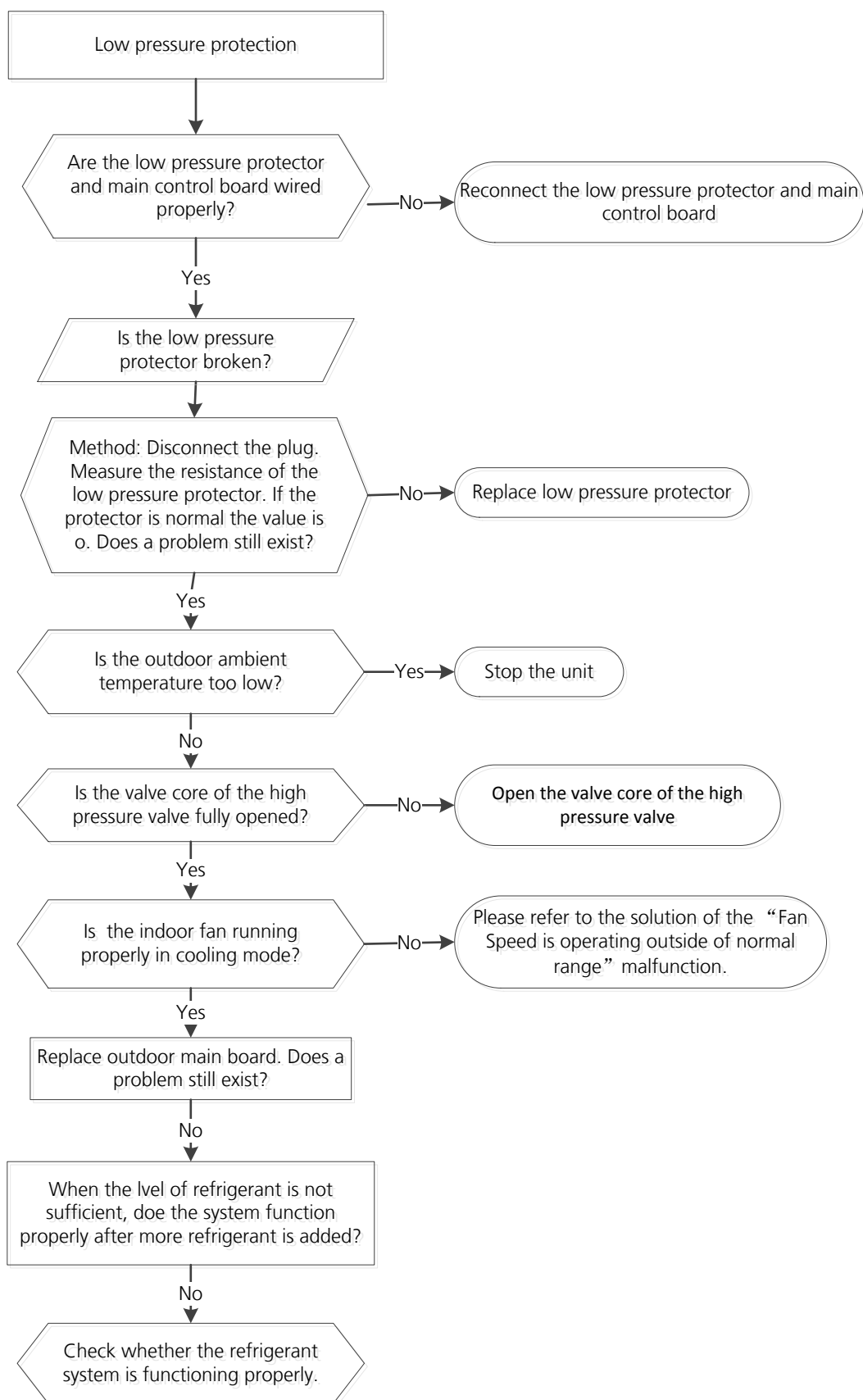

Note: For certain models, outdoor PCB could not be removed separately. In this case, the outdoor electric control box should be replaced as a whole.

TS28: High pressure protection diagnosis and solution

Description: Outdoor pressure switch cut off the system because high pressure is higher than 4.4 MPa

Recommended parts to prepare:

- Connection wires
- Pressure switch
- Outdoor fan
- Outdoor main PCB

Troubleshooting and repair:

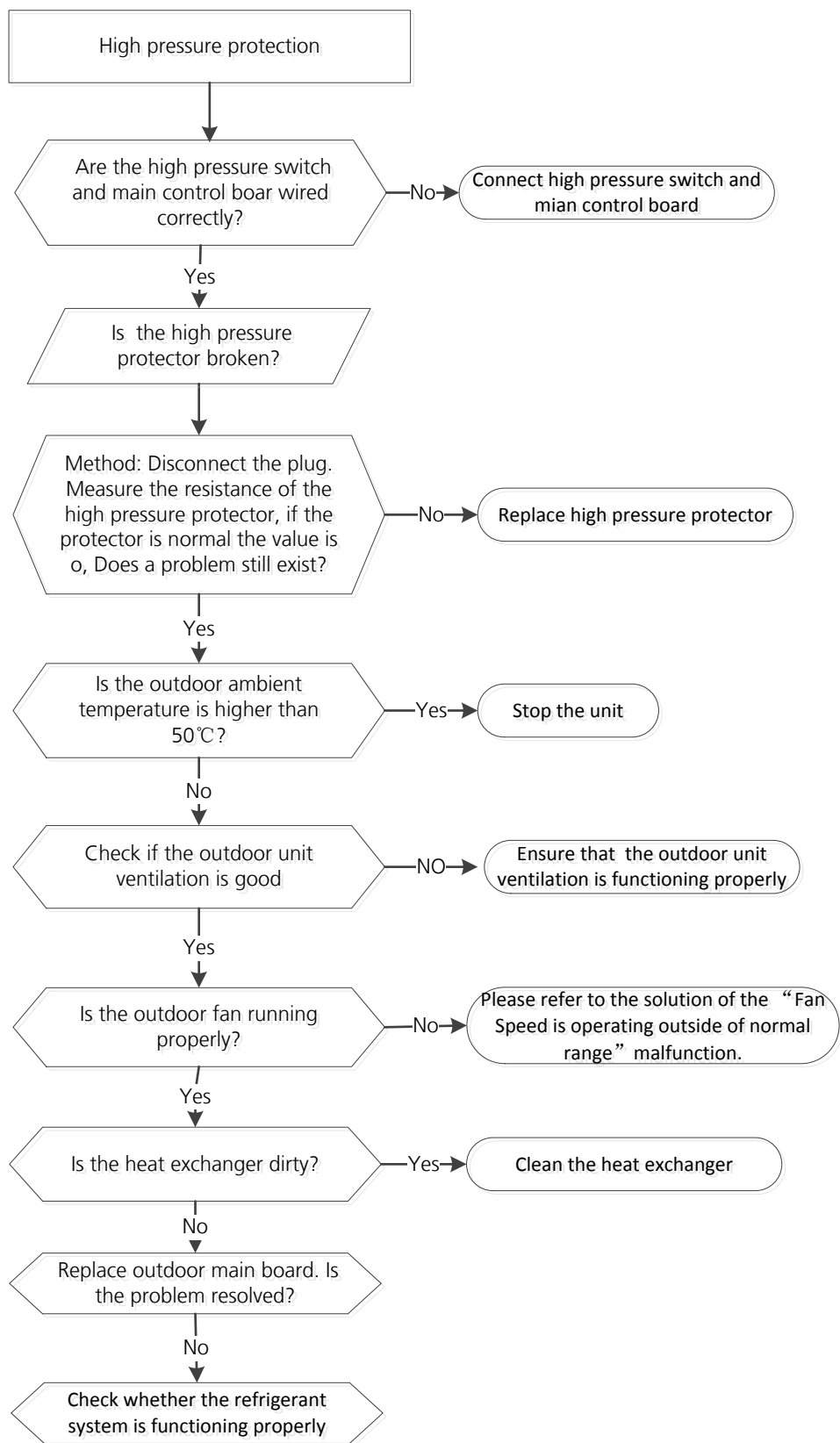

TS31: Communication error between outdoor main PCB and IPM board diagnosis and solution

Description: The main PCB cannot detect the IPM board.

Recommended parts to prepare:

- Connection wires
- IPM board
- Outdoor main PCB
- Electric control box

Troubleshooting and repair:

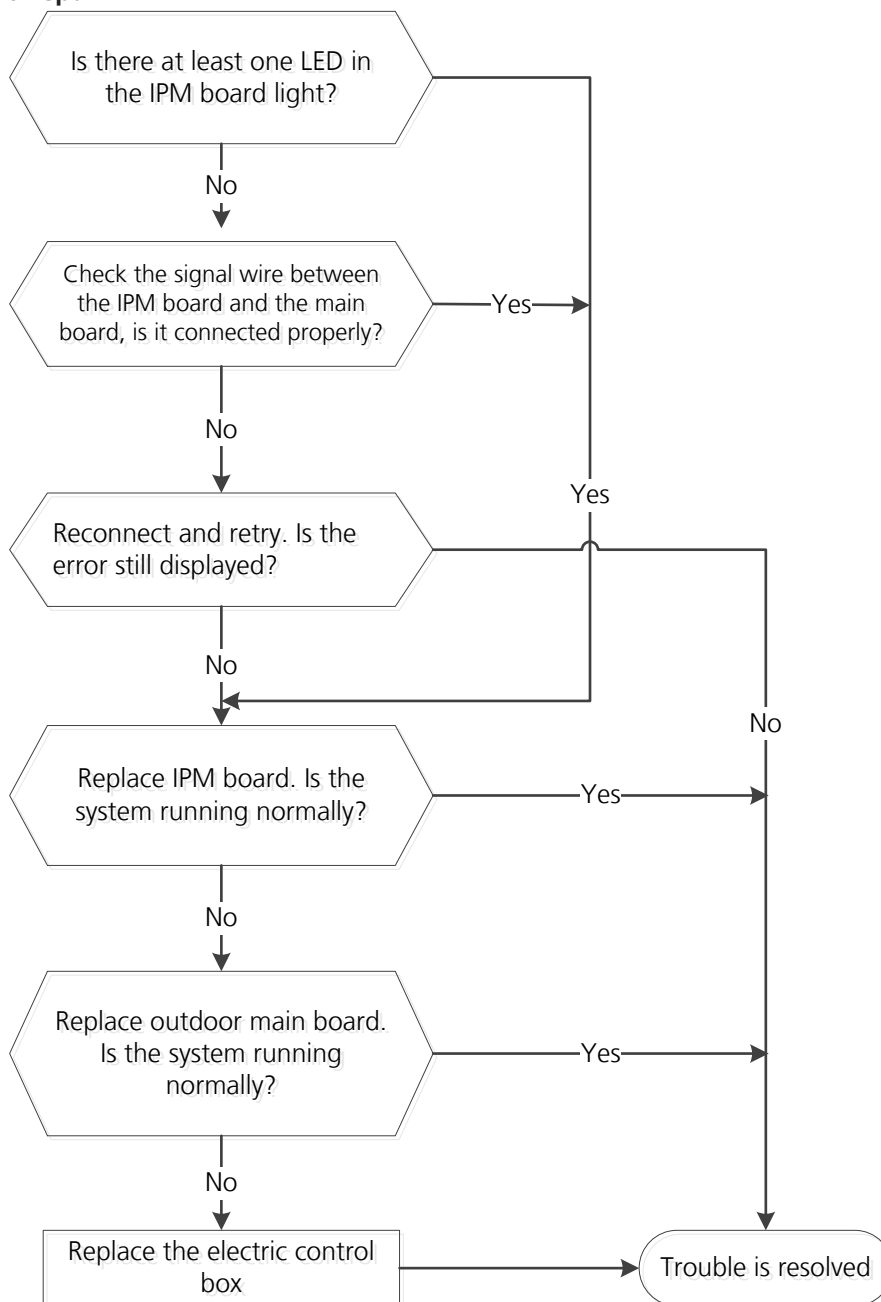

TS32: Discharge temperature protection of compressor diagnosis and solution

Description: If the compressor discharge temperature exceeds a certain level for nine seconds, the compressor ceases operation, the LED displays the failure code

Recommended parts to prepare:

- Connection wires
- Discharge temperature sensor
- Additional refrigerant
- Outdoor main PCB

Troubleshooting and repair:

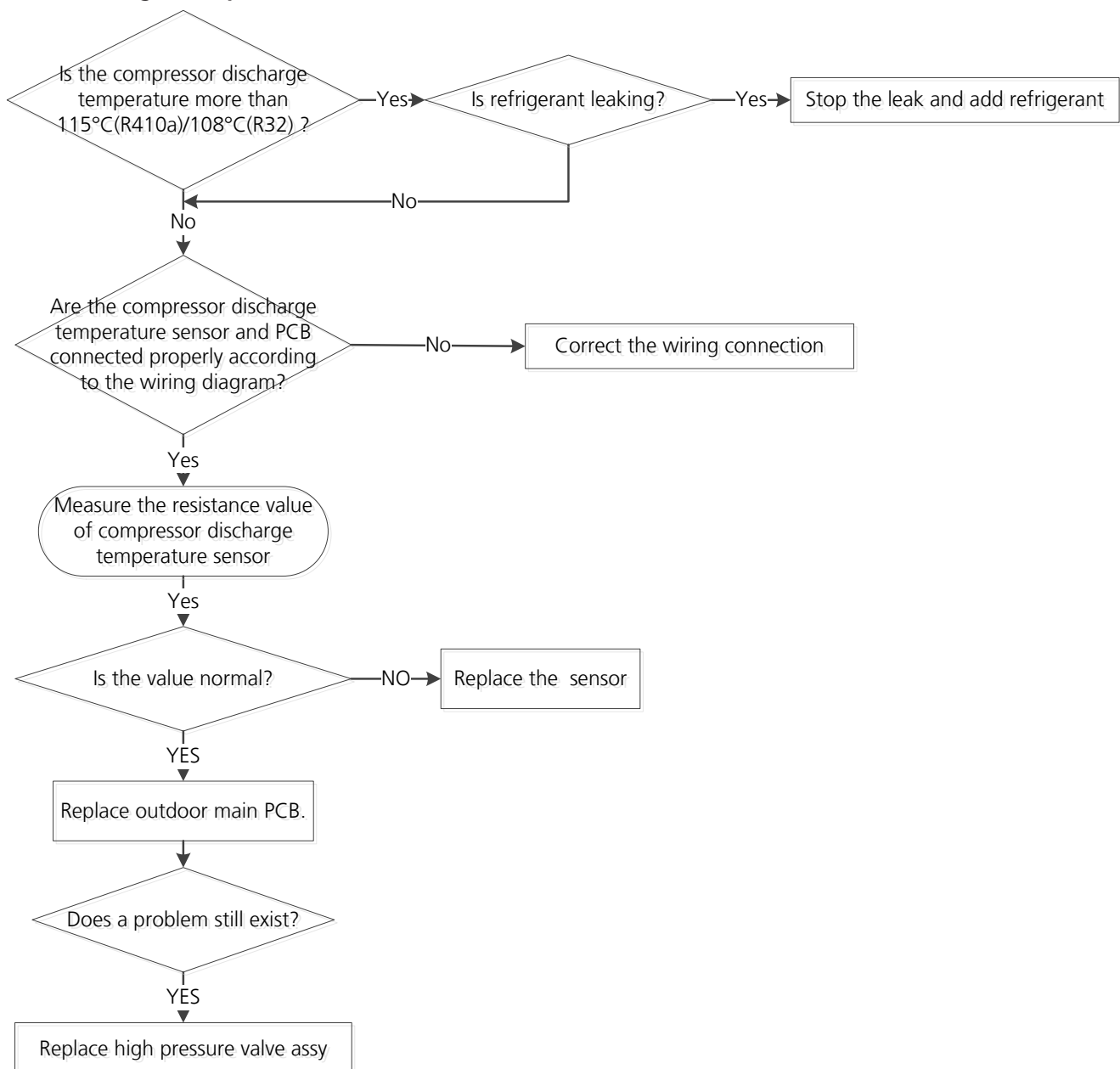

Note: For certain models, outdoor unit uses combination sensor, T3,T4 and TP are the same of sensor. This picture and the value are only for reference, actual appearance and value may vary.

TS27-INV: High temperature protection of condenser diagnosis and solution

Description: When the outdoor pipe temperature is more than 65°C, the unit stops. It starts again only when the outdoor pipe temperature is less than 52°C.

Recommended parts to prepare:

- Connection wires
- Condenser temperature sensor
- Outdoor fan
- Outdoor main PCB
- Refrigerant

Troubleshooting and repair:

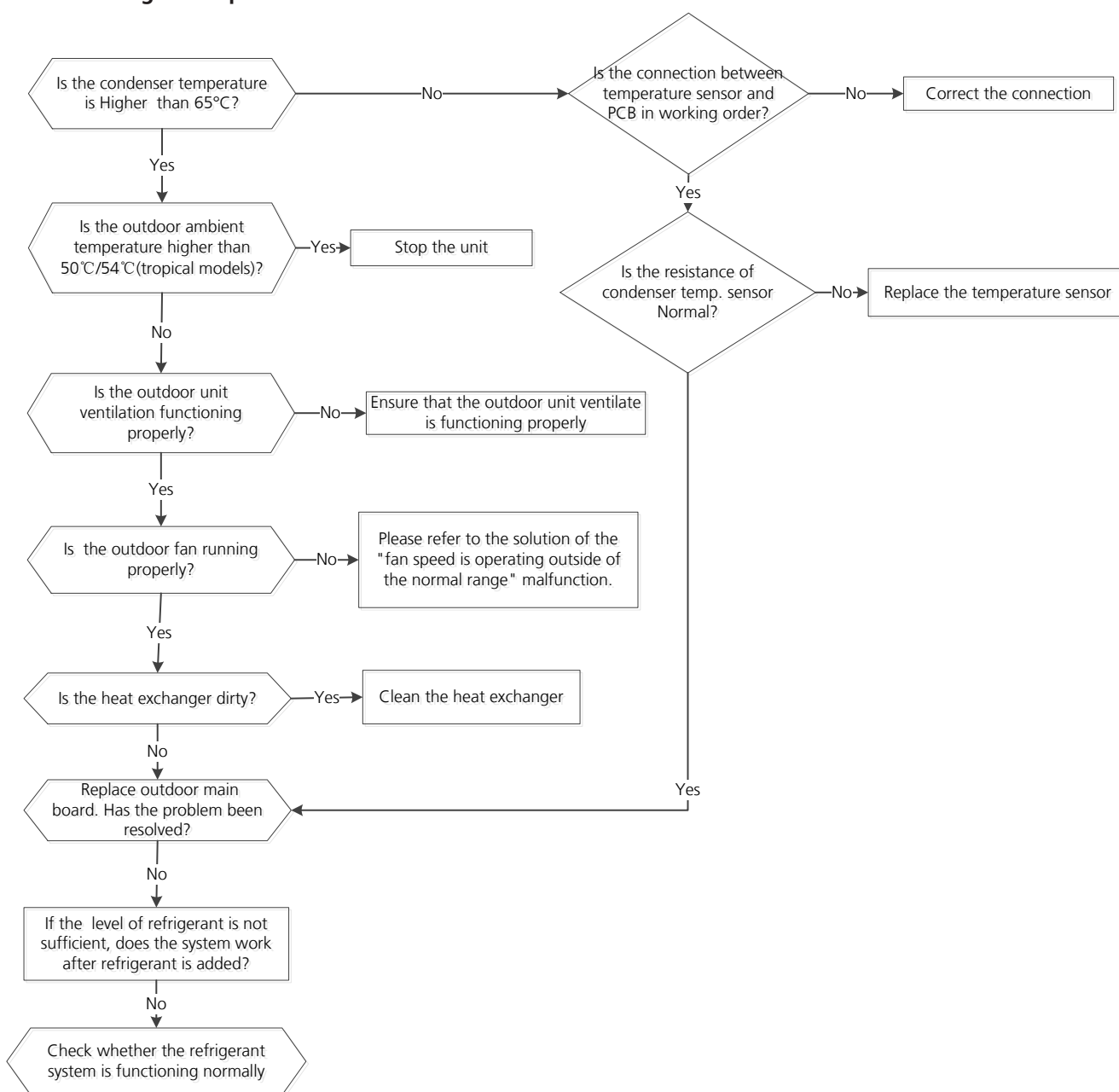

TS30: PFC module protection diagnosis and solution

Description: When the voltage signal that IPM send to compressor drive chip is abnormal, the LED displays the failure code and the AC turns off.

Recommended parts to prepare:

- Connection wires
- Inductance
- Outdoor main PCB
- PFC module

Troubleshooting and repair:

At first test the resistance between every two ports of U, V, W of IPM and P, N. If any result of them is 0 or close to 0, the IPM is defective. Otherwise, please follow the procedure below:

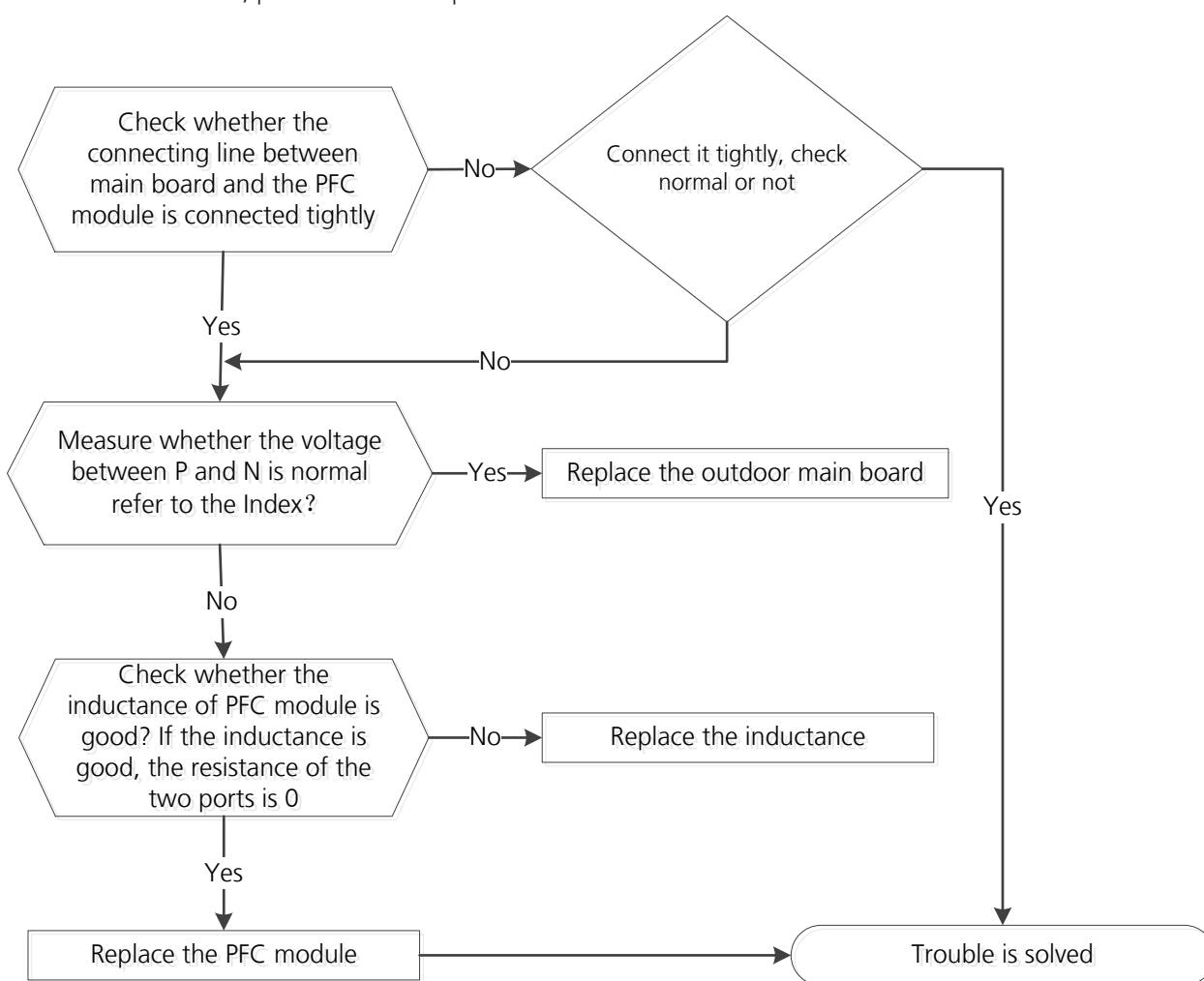

Index:

1. Normal voltage of P and N

208-240V(1-phase,3-phase)		380-415V(3-phase)	
In standby			
around 310VDC		around 530VDC	
In operation			
With passive PFC module	With partial active PFC module	With fully active PFC module	/
>200VDC	>310VDC	>370VDC	>450VDC

2. Reactor Check

Measure the resistance and voltage (to ground) of the reactor. The normal resistance should be around 0.1 ohm. Otherwise, the reactor must have malfunction.

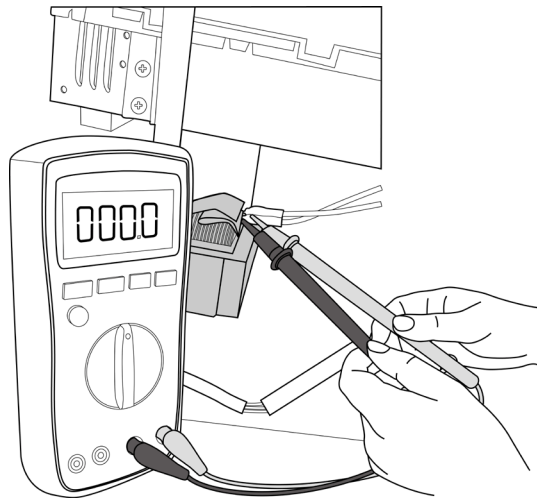

Note: The picture and the value are only for reference, actual condition and specific value may vary.

TS07: Indoor PCB / Display board communication error diagnosis and solution

Description: Indoor PCB does not receive feedback from the display board.

Recommended parts to prepare:

- Communication wire
- Indoor PCB
- Display board

Troubleshooting and repair:

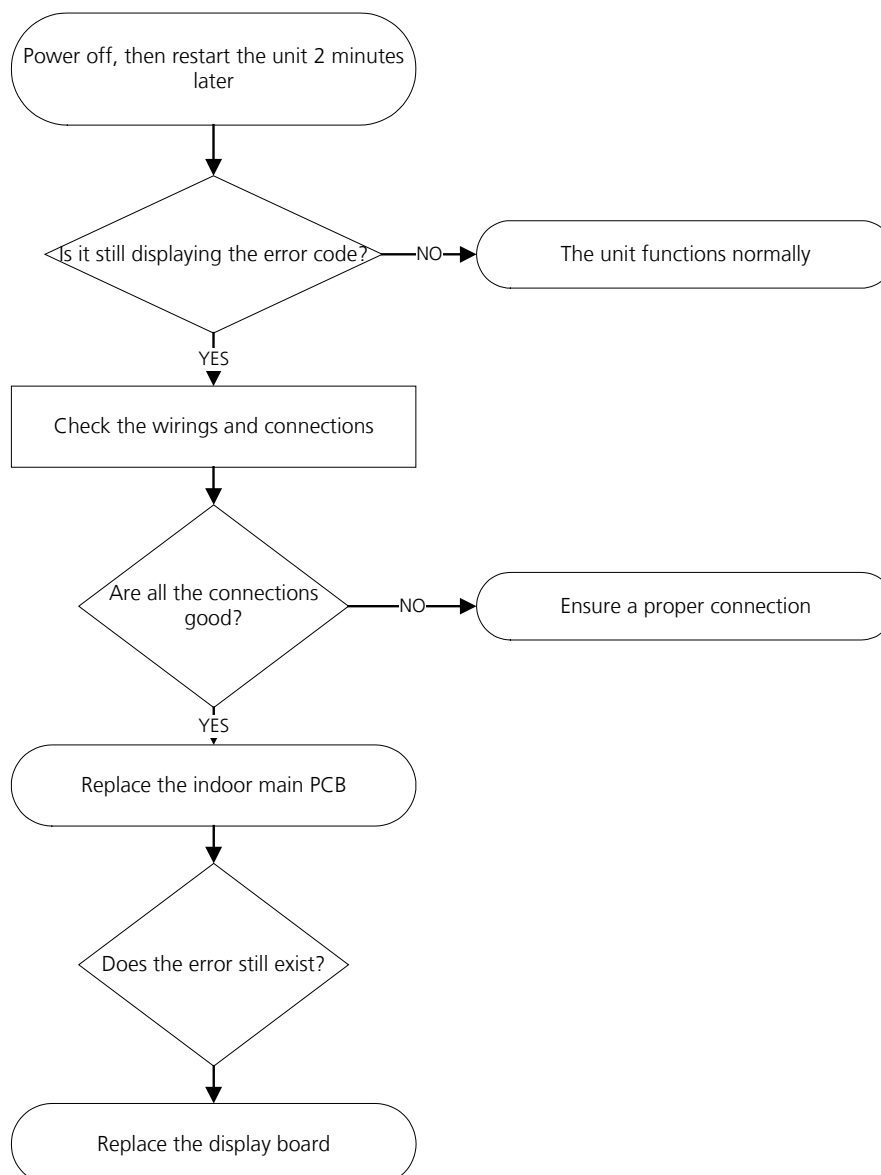

TS38: Lack phase failure of outdoor DC fan motor diagnosis and solution

Description: When the three-phase sampling current of the DC motor is abnormal, especially when the current of one or more phases is always small and almost 0, the LED displays the failure code.

Recommended parts to prepare:

- Connection wire
- Fan motor
- Outdoor PCB

Troubleshooting and repair:

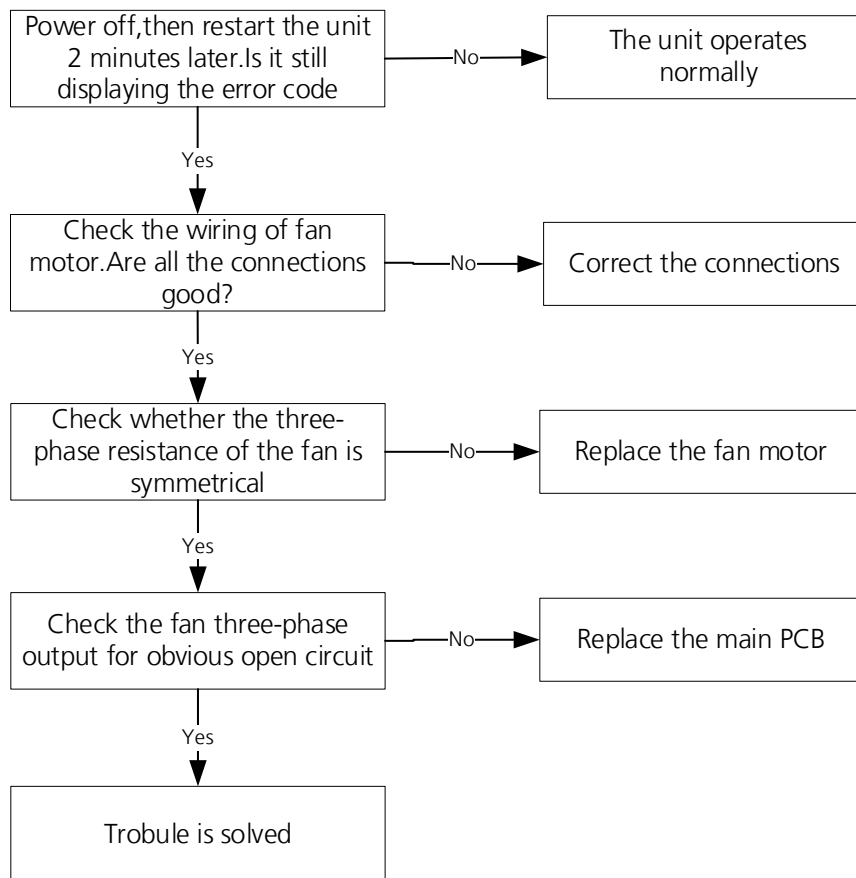

TS39: Outdoor compressor lack phase protection diagnosis and solution

Description: When the three-phase sampling current of the compressor is abnormal, especially when the current of one or more phases is always small and almost 0, the LED displays the failure code

Recommended parts to prepare:

- Connection wire
- Compressor
- Outdoor PCB

Troubleshooting and repair:

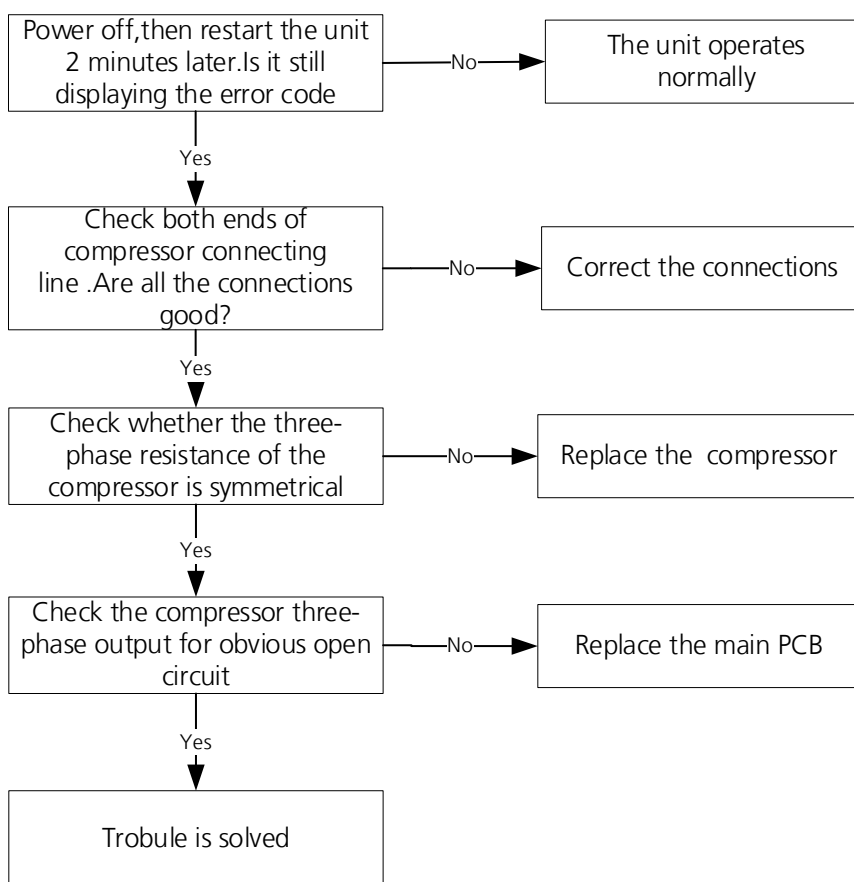

TS40: Outdoor unit IR chip drive failure diagnosis and solution

Description: When the IR chip detects its own parameter error, the LED displays the failure code when power on.

Recommended parts to prepare:

- Inverter module PCB.

Troubleshooting and repair:

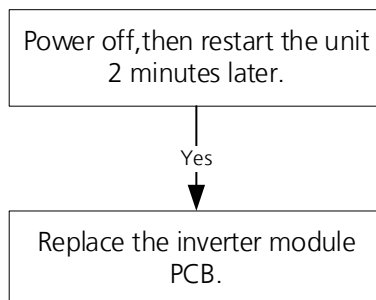

TS41: Communication malfunction between adapter board and outdoor main board diagnosis and solution

Description: The adapter PCB cannot detect the main control board.

Recommended parts to prepare:

- Connection wires
- Adapter board
- Outdoor main PCB

Troubleshooting and repair:

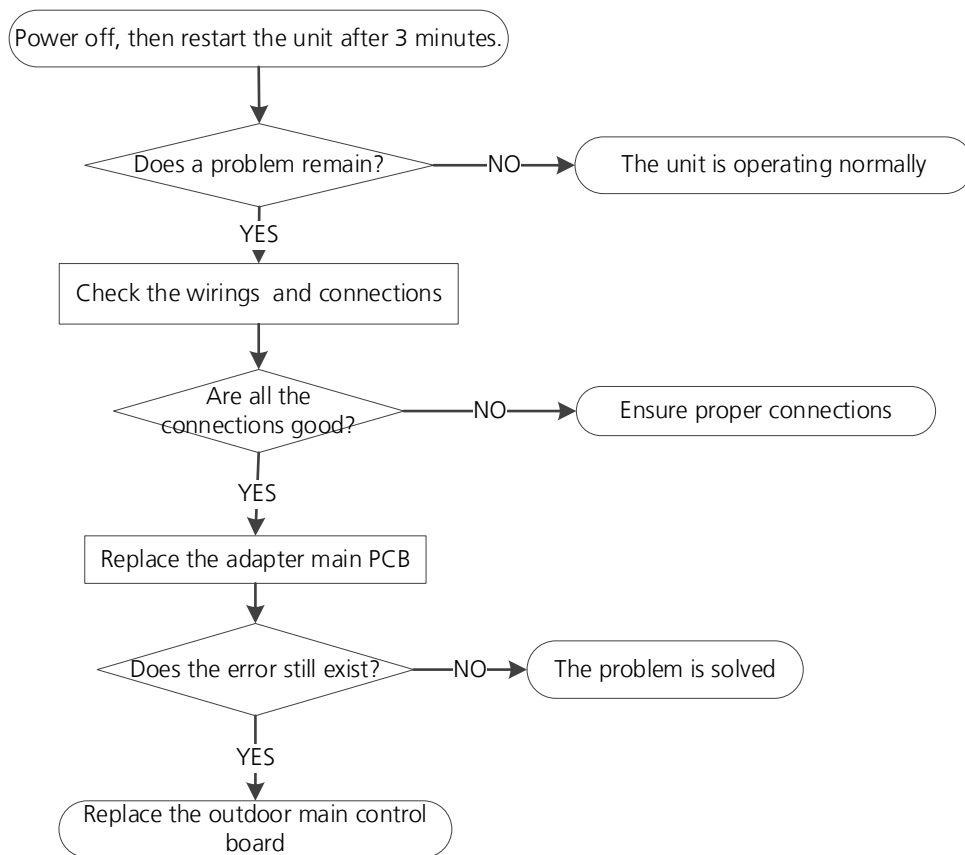

TS44: Communication malfunction between external fan module and indoor unit or External fan DC bus voltage is too low protection or External fan DC bus voltage is too high fault diagnosis and solution

Description: Indoor unit does not receive the feedback from external fan module during 150 seconds.
or Indoor unit receives abnormal increases or decreases in voltage from external fan module.

Recommended parts to prepare:

- Indoor main PCB

Troubleshooting and repair:

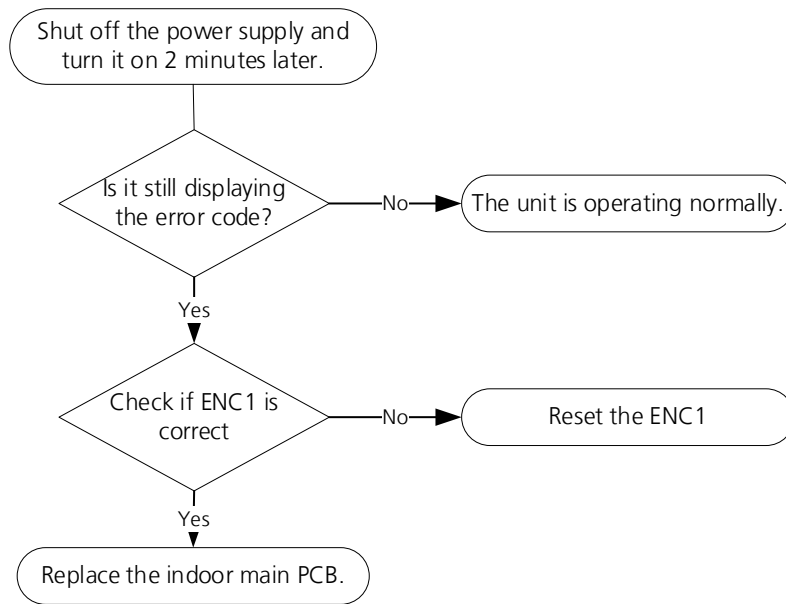

6. Check Procedures

6.1 Temperature Sensor Check

WARNING

Be sure to turn off all power supplies or disconnect all wires to avoid electric shock. Operate after compressor and coil have returned to normal temperature in case of injury.

1. Disconnect the temperature sensor from PCB (Refer to Chapter 5&6. Indoor&Outdoor Unit Disassembly).
2. Measure the resistance value of the sensor using a multi-meter.
3. Check corresponding temperature sensor resistance value table (Refer to Chapter 8. Appendix).

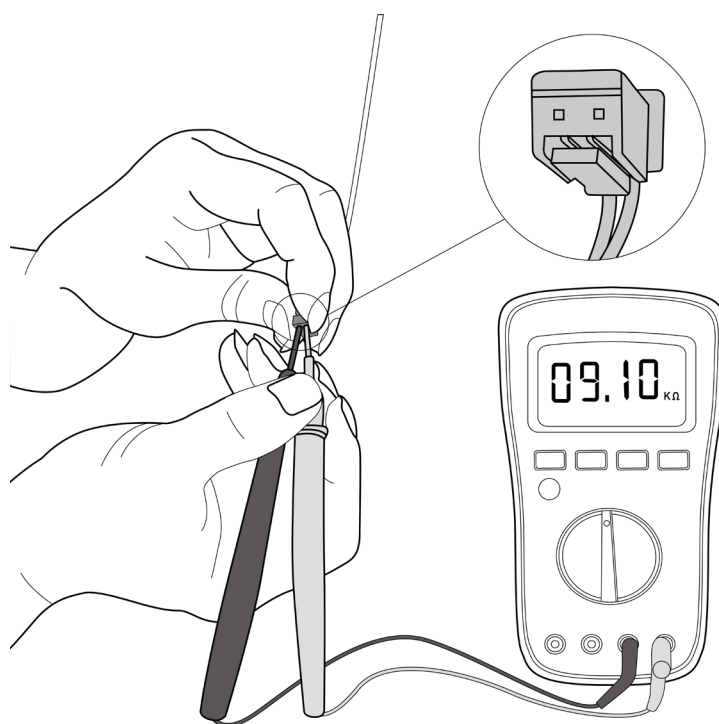

Note: The picture and the value are only for reference, actual condition and specific value may vary.

9.2 Compressor Check

1. Disconnect the compressor power cord from outdoor PCB (Refer to Chapter 6. Outdoor Unit Disassembly)).
2. Measure the resistance value of each winding using a multi-meter.
3. Check the resistance value of each winding in the following table.

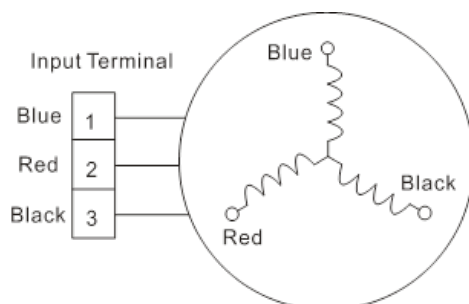

Resistance Value	KTN150D30UFZA	KTM240D43UKT	KTF310D43UMT	ATQ360D1UMU
Blue-Red	1.02Ω	1.03Ω	0.65Ω	0.37 Ω
Blue-Black				
Red-Black				

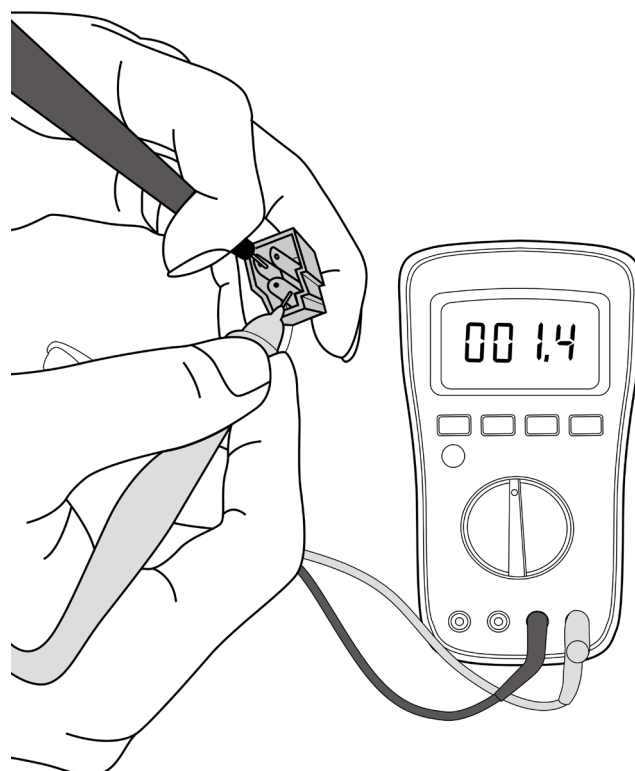

Note: The picture and the value are only for reference, actual condition and specific value may vary.

9.3 IPM Continuity Check

⚠ WARNING

Electricity remains in capacitors even when the power supply is off. Ensure the capacitors are fully discharged before troubleshooting.

1. Turn off outdoor unit and disconnect power supply.
2. Discharge electrolytic capacitors and ensure all energy-storage unit has been discharged.
3. Disassemble outdoor PCB or disassemble IPM board.
4. Measure the resistance value between P and U(V, W, N); U(V, W) and N.

Digital tester		Resistance value	Digital tester		Resistance value
(+)Red	(-)Black		(+)Red	(-)Black	
P	N	∞ (Several MΩ)	U	N	∞ (Several MΩ)
	U		V		
	V		W		
	W		-		

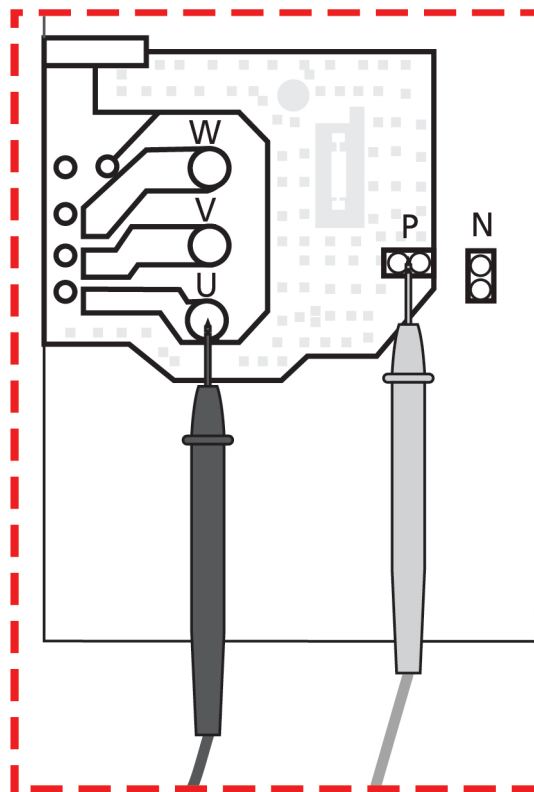

Note: The picture and the value are only for reference, actual condition and specific value may vary.

Appendix

Contents

i)	Temperature Sensor Resistance Value Table for T1, T2, T3, and T4 (°C – K) ..	239
ii)	Temperature Sensor Resistance Value Table for TP (°C – K).....	240
iii)	Pressure On Service Port.....	241

i) Temperature Sensor Resistance Value Table for T1,T2,T3 and T4 (°C – K)

°C	°F	K Ohm	°C	°F	K Ohm	°C	°F	K Ohm	°C	°F	K Ohm
-20	-4	115.266	20	68	12.6431	60	140	2.35774	100	212	0.62973
-19	-2	108.146	21	70	12.0561	61	142	2.27249	101	214	0.61148
-18	0	101.517	22	72	11.5	62	144	2.19073	102	216	0.59386
-17	1	96.3423	23	73	10.9731	63	145	2.11241	103	217	0.57683
-16	3	89.5865	24	75	10.4736	64	147	2.03732	104	219	0.56038
-15	5	84.219	25	77	10	65	149	1.96532	105	221	0.54448
-14	7	79.311	26	79	9.55074	66	151	1.89627	106	223	0.52912
-13	9	74.536	27	81	9.12445	67	153	1.83003	107	225	0.51426
-12	10	70.1698	28	82	8.71983	68	154	1.76647	108	226	0.49989
-11	12	66.0898	29	84	8.33566	69	156	1.70547	109	228	0.486
-10	14	62.2756	30	86	7.97078	70	158	1.64691	110	230	0.47256
-9	16	58.7079	31	88	7.62411	71	160	1.59068	111	232	0.45957
-8	18	56.3694	32	90	7.29464	72	162	1.53668	112	234	0.44699
-7	19	52.2438	33	91	6.98142	73	163	1.48481	113	235	0.43482
-6	21	49.3161	34	93	6.68355	74	165	1.43498	114	237	0.42304
-5	23	46.5725	35	95	6.40021	75	167	1.38703	115	239	0.41164
-4	25	44	36	97	6.13059	76	169	1.34105	116	241	0.4006
-3	27	41.5878	37	99	5.87359	77	171	1.29078	117	243	0.38991
-2	28	39.8239	38	100	5.62961	78	172	1.25423	118	244	0.37956
-1	30	37.1988	39	102	5.39689	79	174	1.2133	119	246	0.36954
0	32	35.2024	40	104	5.17519	80	176	1.17393	120	248	0.35982
1	34	33.3269	41	106	4.96392	81	178	1.13604	121	250	0.35042
2	36	31.5635	42	108	4.76253	82	180	1.09958	122	252	0.3413
3	37	29.9058	43	109	4.5705	83	181	1.06448	123	253	0.33246
4	39	28.3459	44	111	4.38736	84	183	1.03069	124	255	0.3239
5	41	26.8778	45	113	4.21263	85	185	0.99815	125	257	0.31559
6	43	25.4954	46	115	4.04589	86	187	0.96681	126	259	0.30754
7	45	24.1932	47	117	3.88673	87	189	0.93662	127	261	0.29974
8	46	22.5662	48	118	3.73476	88	190	0.90753	128	262	0.29216
9	48	21.8094	49	120	3.58962	89	192	0.8795	129	264	0.28482
10	50	20.7184	50	122	3.45097	90	194	0.85248	130	266	0.2777
11	52	19.6891	51	124	3.31847	91	196	0.82643	131	268	0.27078
12	54	18.7177	52	126	3.19183	92	198	0.80132	132	270	0.26408
13	55	17.8005	53	127	3.07075	93	199	0.77709	133	271	0.25757
14	57	16.9341	54	129	2.95896	94	201	0.75373	134	273	0.25125
15	59	16.1156	55	131	2.84421	95	203	0.73119	135	275	0.24512
16	61	15.3418	56	133	2.73823	96	205	0.70944	136	277	0.23916
17	63	14.6181	57	135	2.63682	97	207	0.68844	137	279	0.23338
18	64	13.918	58	136	2.53973	98	208	0.66818	138	280	0.22776
19	66	13.2631	59	138	2.44677	99	210	0.64862	139	282	0.22231

ii) Temperature Sensor Resistance Value Table for TP (°C – K)

°C	°F	K Ohm	°C	°F	K Ohm	°C	°F	K Ohm	°C	°F	K Ohm
-20	-4	542.7	20	68	68.66	60	140	13.59	100	212	3.702
-19	-2	511.9	21	70	65.62	61	142	13.11	101	214	3.595
-18	0	483	22	72	62.73	62	144	12.65	102	216	3.492
-17	1	455.9	23	73	59.98	63	145	12.21	103	217	3.392
-16	3	430.5	24	75	57.37	64	147	11.79	104	219	3.296
-15	5	406.7	25	77	54.89	65	149	11.38	105	221	3.203
-14	7	384.3	26	79	52.53	66	151	10.99	106	223	3.113
-13	9	363.3	27	81	50.28	67	153	10.61	107	225	3.025
-12	10	343.6	28	82	48.14	68	154	10.25	108	226	2.941
-11	12	325.1	29	84	46.11	69	156	9.902	109	228	2.86
-10	14	307.7	30	86	44.17	70	158	9.569	110	230	2.781
-9	16	291.3	31	88	42.33	71	160	9.248	111	232	2.704
-8	18	275.9	32	90	40.57	72	162	8.94	112	234	2.63
-7	19	261.4	33	91	38.89	73	163	8.643	113	235	2.559
-6	21	247.8	34	93	37.3	74	165	8.358	114	237	2.489
-5	23	234.9	35	95	35.78	75	167	8.084	115	239	2.422
-4	25	222.8	36	97	34.32	76	169	7.82	116	241	2.357
-3	27	211.4	37	99	32.94	77	171	7.566	117	243	2.294
-2	28	200.7	38	100	31.62	78	172	7.321	118	244	2.233
-1	30	190.5	39	102	30.36	79	174	7.086	119	246	2.174
0	32	180.9	40	104	29.15	80	176	6.859	120	248	2.117
1	34	171.9	41	106	28	81	178	6.641	121	250	2.061
2	36	163.3	42	108	26.9	82	180	6.43	122	252	2.007
3	37	155.2	43	109	25.86	83	181	6.228	123	253	1.955
4	39	147.6	44	111	24.85	84	183	6.033	124	255	1.905
5	41	140.4	45	113	23.89	85	185	5.844	125	257	1.856
6	43	133.5	46	115	22.89	86	187	5.663	126	259	1.808
7	45	127.1	47	117	22.1	87	189	5.488	127	261	1.762
8	46	121	48	118	21.26	88	190	5.32	128	262	1.717
9	48	115.2	49	120	20.46	89	192	5.157	129	264	1.674
10	50	109.8	50	122	19.69	90	194	5	130	266	1.632
11	52	104.6	51	124	18.96	91	196	4.849			
12	54	99.69	52	126	18.26	92	198	4.703			
13	55	95.05	53	127	17.58	93	199	4.562			
14	57	90.66	54	129	16.94	94	201	4.426			
15	59	86.49	55	131	16.32	95	203	4.294			
16	61	82.54	56	133	15.73	96	205	4.167			
17	63	78.79	57	135	15.16	97	207	4.045			
18	64	75.24	58	136	14.62	98	208	3.927			
19	66	71.86	59	138	14.09	99	210	3.812			

iii) Pressure On Service Port(R410A)

Cooling chart:

°F(°C)	ODU(DB)		0(-17)	5(-15)	15(-9.44)	45(7.22)	75(23.89)	85(29.44)	95(35)	105(40.56)	115(46.11)	120(48.89)
	IDU(DB/WB)											
BAR	70/59 (21.11/15)		6.4	6.5	7.3	8.0	8.2	7.8	8.1	8.6	10.1	10.6
	75/63 (23.89/17.22)		6.7	6.8	7.9	8.6	8.6	8.3	8.7	9.1	10.7	11.2
	80/67 (26.67/19.44)		7.1	7.2	8.5	9.5	9.3	8.9	9.1	9.6	11.2	11.9
	90/73 (32.22/22.78)		7.7	7.8	9.6	10.5	10.3	9.5	10.0	10.6	12.4	13.0
PSI	70/59 (21.11/15)		93	94	106	116	119	113	117	125	147	154
	75/63 (23.89/17.22)		97	99	115	125	124	120	126	132	155	162
	80/67 (26.67/19.44)		103	104	123	138	135	129	132	140	162	173
	90/73 (32.22/22.78)		112	113	139	152	149	138	145	154	180	189
MPa	70/59 (21.11/15)		0.64	0.65	0.73	0.8	0.82	0.78	0.81	0.86	1.01	1.06
	75/63 (23.89/17.22)		0.67	0.68	0.79	0.86	0.86	0.83	0.87	0.91	1.07	1.12
	80/67 (26.67/19.44)		0.71	0.72	0.85	0.95	0.93	0.89	0.91	0.96	1.12	1.19
	90/73 (32.22/22.78)		0.77	0.78	0.96	1.05	1.03	0.95	1	1.06	1.24	1.3

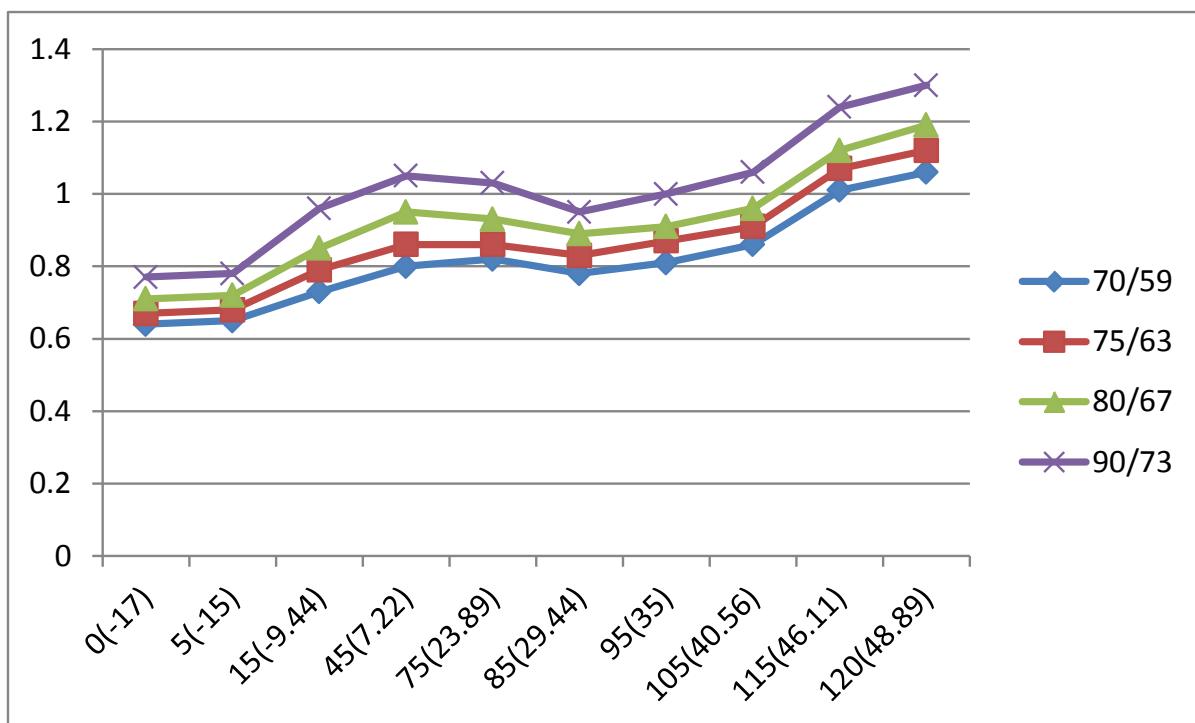

Heating chart:

°F(°C)	ODU(DB/WB)	57/53 (13.89/11.67)	47/43 (8.33/6.11)	37/33 (2.78/0.56)	27/23 (-2.78/-5)	17/13 (-8.33/- 10.56)	0/-2 (-17/-19)	-17/-18 (-27/-28)
	IDU(DB)							
BAR	55(12.78)	30.3	28.5	25.3	22.8	20.8	18.5	16.5
	65(18.33)	32.5	30.0	26.6	25.4	23.3	20.5	19.0
	75(23.89)	33.8	31.5	27.8	26.3	24.9	21.5	20.0
PSI	55(12.78)	439	413	367	330	302	268	239
	65(18.33)	471	435	386	368	339	297	276
	75(23.89)	489	457	403	381	362	312	290
MPa	55(12.78)	3.03	2.85	2.53	2.28	2.08	1.85	1.65
	65(18.33)	3.25	3.00	2.66	2.54	2.33	2.05	1.90
	75(23.89)	3.38	3.15	2.78	2.63	2.49	2.15	2.00

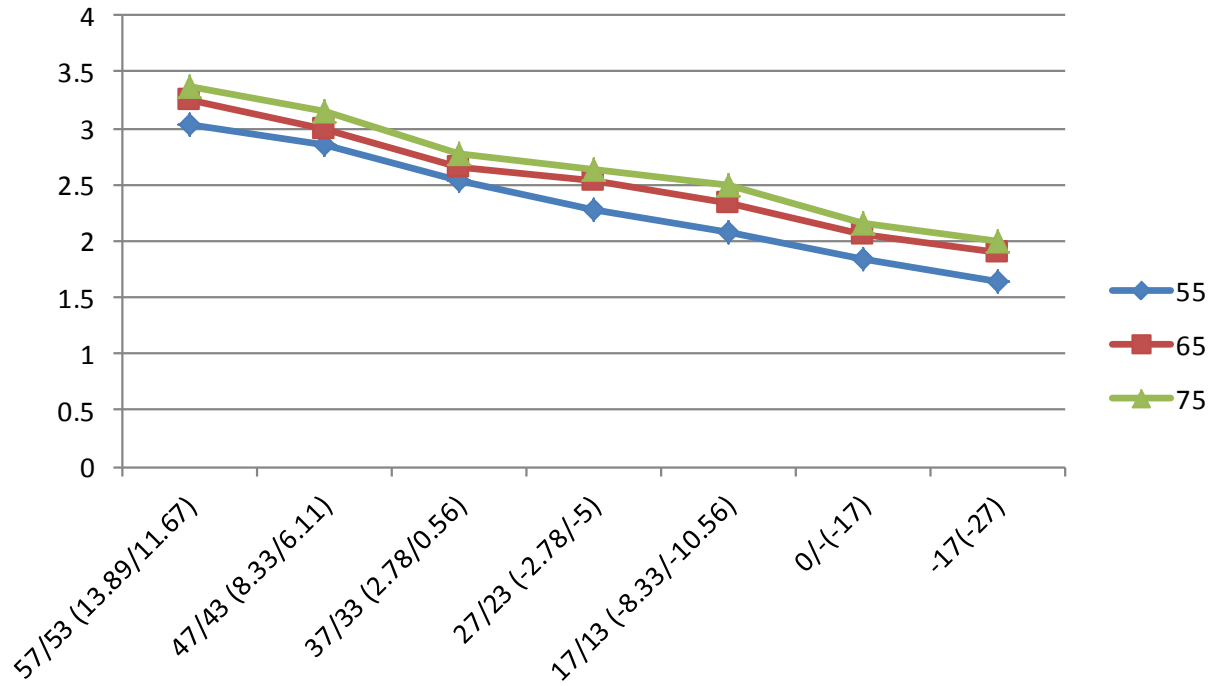

System Pressure Table-R410A

Pressure			Temperature		Pressure			Temperature	
Kpa	bar	PSI	°C	°F	Kpa	bar	PSI	°C	°F
100	1	14.5	-51.623	-60.921	2350	23.5	340.75	38.817	101.871
150	1.5	21.75	-43.327	-45.989	2400	24	348	39.68	103.424
200	2	29	-36.992	-34.586	2450	24.5	355.25	40.531	104.956
250	2.5	36.25	-31.795	-25.231	2500	25	362.5	41.368	106.462
300	3	43.5	-27.351	-17.232	2550	25.5	369.75	42.192	107.946
350	3.5	50.75	-23.448	-10.206	2600	26	377	43.004	109.407
400	4	58	-19.953	-3.915	2650	26.5	384.25	43.804	110.847
450	4.5	65.25	-16.779	1.798	2700	27	391.5	44.592	112.266
500	5	72.5	-13.863	7.047	2750	27.5	398.75	45.37	113.666
550	5.5	79.75	-11.162	11.908	2800	28	406	46.136	115.045
600	6	87	-8.643	16.444	2850	28.5	413.25	46.892	116.406
650	6.5	94.25	-6.277	20.701	2900	29	420.5	47.638	117.748
700	7	101.5	-4.046	24.716	2950	29.5	427.75	48.374	119.073
750	7.5	108.75	-1.933	28.521	3000	30	435	49.101	120.382
800	8	116	0.076	32.137	3050	30.5	442.25	49.818	121.672
850	8.5	123.25	1.993	35.587	3100	31	449.5	50.525	122.945
900	9	130.5	3.826	38.888	3150	31.5	456.75	51.224	124.203
950	9.5	137.75	5.584	42.052	3200	32	464	51.914	125.445
1000	10	145	7.274	45.093	3250	32.5	471.25	52.596	126.673
1050	10.5	152.25	8.901	48.022	3300	33	478.5	53.27	127.886
1100	11	159.5	10.471	50.848	3350	33.5	485.75	53.935	129.083
1150	11.5	166.75	11.988	53.578	3400	34	493	54.593	130.267
1200	12	174	13.457	56.223	3450	34.5	500.25	55.243	131.437
1250	12.5	181.25	14.879	58.782	3500	35	507.5	55.885	132.593
1300	13	188.5	16.26	61.268	3550	35.5	514.75	56.52	133.736
1350	13.5	195.75	17.602	63.684	3600	36	522	57.148	134.866
1400	14	203	18.906	66.031	3650	36.5	529.25	57.769	135.984
1450	14.5	210.25	20.176	68.317	3700	37	536.5	58.383	137.089
1500	15	217.5	21.414	70.545	3750	37.5	543.75	58.99	138.182
1550	15.5	224.75	22.621	72.718	3800	38	551	59.591	139.264
1600	16	232	23.799	74.838	3850	38.5	558.25	60.185	140.333
1650	16.5	239.25	24.949	76.908	3900	39	565.5	60.773	141.391
1700	17	246.5	26.074	78.933	3950	39.5	572.75	61.355	142.439
1750	17.5	253.75	27.174	80.913	4000	40	580	61.93	143.474
1800	18	261	28.251	82.852	4050	40.5	587.25	62.499	144.498
1850	18.5	268.25	29.305	84.749	4100	41	594.5	63.063	145.513
1900	19	275.5	30.338	86.608	4150	41.5	601.75	63.62	146.516
1950	19.5	282.75	31.351	88.432	4200	42	609	64.172	147.510
2000	20	290	32.344	90.219	4250	42.5	616.25	64.719	148.494
2050	20.5	297.25	33.319	91.974	4300	43	623.5	65.259	149.466
2100	21	304.5	34.276	93.697	4350	43.5	630.75	65.795	150.431
2150	21.5	311.75	35.215	95.387	4400	44	638	66.324	151.383
2200	22	319	36.139	97.050	4450	44.5	645.25	66.849	152.328
2250	22.5	326.25	37.047	98.685	4500	45	652.5	67.368	153.262
2300	23	333.5	37.939	100.290					