

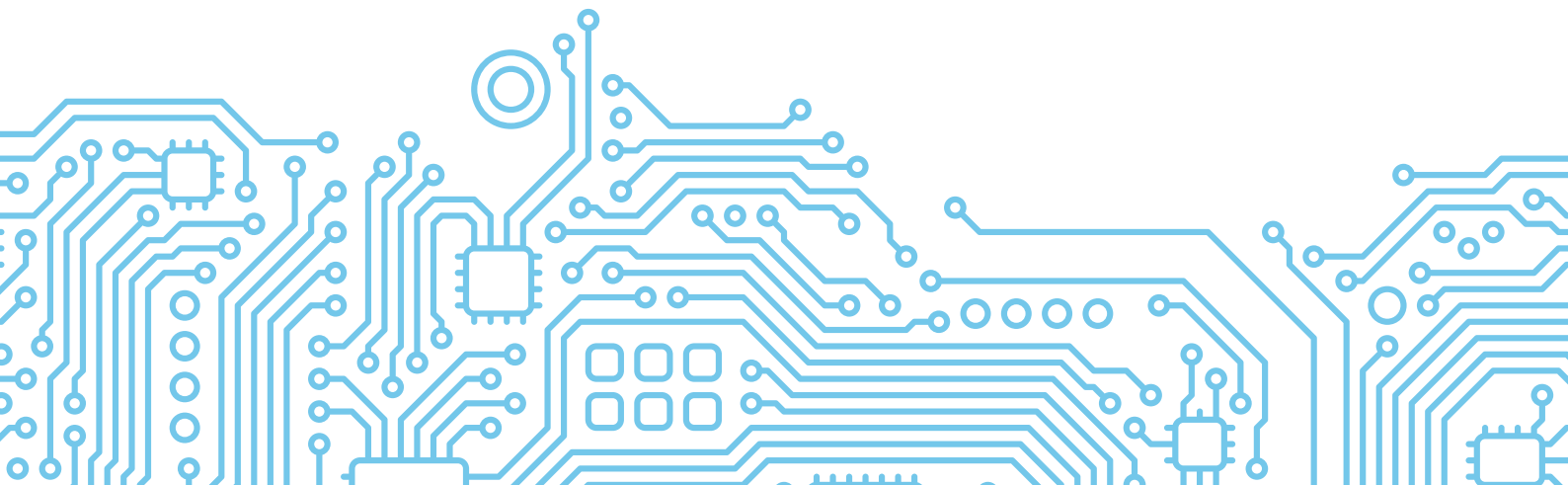

# TECHNICAL MANUAL

---



---

## Table of Contents

Page

<b>1. Specifications .....</b>	<b>4</b>
1. Model Reference	
2. External Appearance	
3. Features	
4. Part names of Indoor units	
5. General Specifications	
6. Indoor Unit Combination	
7. Dimensional Drawings	
8. Centre of Gravity	
9. Air Velocity and Temperature Distributions	
10. Electrical Wiring Diagrams	
11. Refrigerant Cycle Diagrams	
12. Capacity Tables	
13. Noise Criterion Curves	
14. Electrical Characteristics	
15. Static Pressure	
<b>2. Product Features .....</b>	<b>99</b>
1. Operation Modes and Functions	
2. Remote Controller Functions	
<b>3. Troubleshooting .....</b>	<b>122</b>
1. Safety Caution	
2. General Troubleshooting	
3. Complain Record Form	
4. Information Inquiry	

---

## Table of Contents

Page

- 5. Outdoor Unit Point Check Function
- 6. Error Diagnosis and Troubleshooting Without Error Code
- 7. Quick Maintenance by Error Code
- 8. Troubleshooting by Error Code
- 9. Check Procedures

## Appendix ..... 180

- i) Temperature Sensor Resistance Value Table for T1,T2,T3 and T4 (°C – K)
- ii) Temperature Sensor Resistance Value Table for TP (°C – K)
- iii) Pressure On Service Port

---

# Specifications

## Contents

1.	Model Reference.....	5
2.	External Appearance .....	6
3.	Features .....	8
4.	Part names of Indoor units .....	16
5.	General Specifications.....	18
6.	Indoor Unit Combination .....	23
7.	Dimensional Drawings .....	24
8.	Centre of Gravity .....	31
9.	Air Velocity and Temperature Distributions .....	33
10.	Electrical Wiring Diagrams.....	61
11	Refrigerant Cycle Diagrams .....	79
12	Capacity Tables .....	83
13.	Noise Criterion Curves.....	85
14.	Electrical Characteristics .....	94
15.	Static Pressure.....	95

## 1. Model Reference

Refer to the following table to determine the specific indoor and outdoor unit model number of your purchased equipment.

	Indoor Unit	Master Indoor Unit Model	Product code	Outdoors Unit	Master Outdoor Unit Model	Product code	Power Supply
A6 Duct Type	MTIU-09HWFN1-M		22023011003874	M2OF-18HFN1-M M3OF-27HFN1-M M4OF-36HFN1-M M5OF-48HFN1-M	DM18HOM23230X2 DM27HOM23230X2 DM18HOM23230X2 DM48HOM23230X2	22022316000385 22022316000327 22022316000385 22022316000545	1Φ, 208-230V~, 60Hz
	MTIU-12HWFN1-M		22023011003875				
	MTIU-18HWFN1-M		22023011003474				
	MTIU-24HWFN1-M		22023010005183				
Compact Cassette type	MCA3U-09HRFN1-M(C)	DM09HICU230X5	22022511000703				
	MCA3U-12HRFN1-M(C)	DM12HICU230X5	22022511000710				
Super-slim Cassette type	MCDU-24HRFN1-M(C)	DM24HICU230X5	22022511000481				
Floor ceiling type							
Wall mounted type							

## 2. External Appearance

### 2.1 Indoor Unit

Compact Four-way Cassette Type



Super Slim Four-way Cassette Type



Floor Ceiling Type



A6 Duct type



Wall Mounted Type

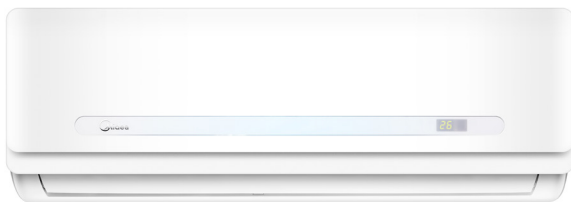

## 2.2 Outdoor Unit

Single Fan Outdoor Unit



Double Fan Outdoor Unit



## 3. Functions

### 3.1 A6 Duct Type

#### 3.1.1 High Static Pressure

Capable to be installed in various applications that requires static pressure of 160Pa.

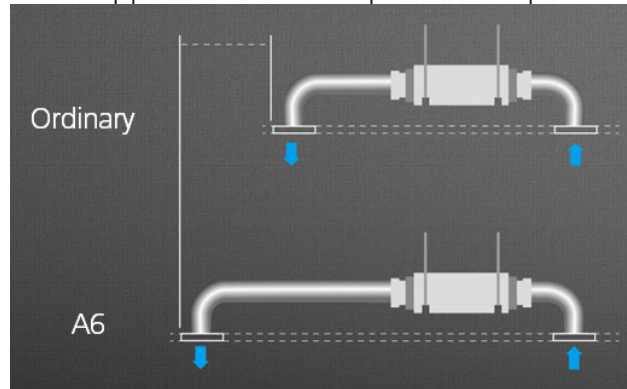

#### 3.1.2 Eccentric Fan Design

New eccentric fan design improves the airflow at the air outlet, resulting better performance.

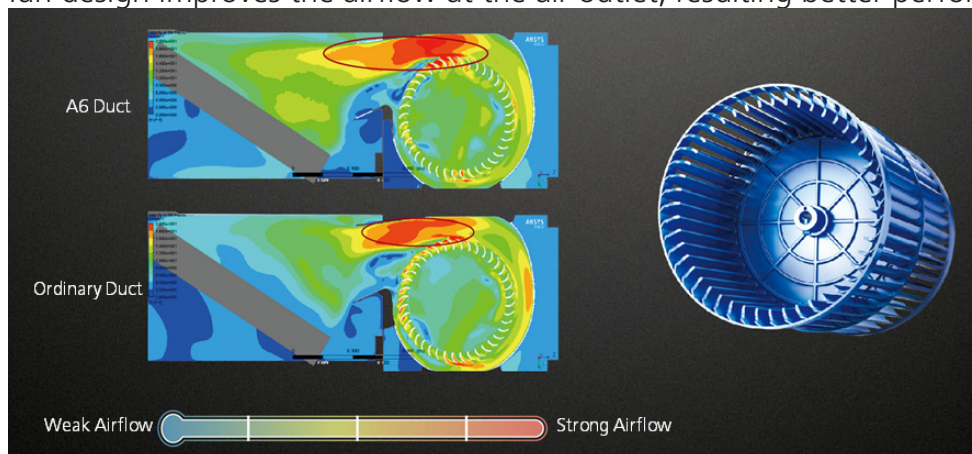

#### 3.1.3 Slim Design

The industry lowest height is designed to be fitted into tight roof space.

#### 3.1.4 2 Types Installation

Two types of installation methods can be selected: ceiling concealed and floor concealed(optional)





### 3.1.5 Flexible Air Intake

The frame size of air inlet in rear and bottom is the same. It's very easy to switch to match different applications.

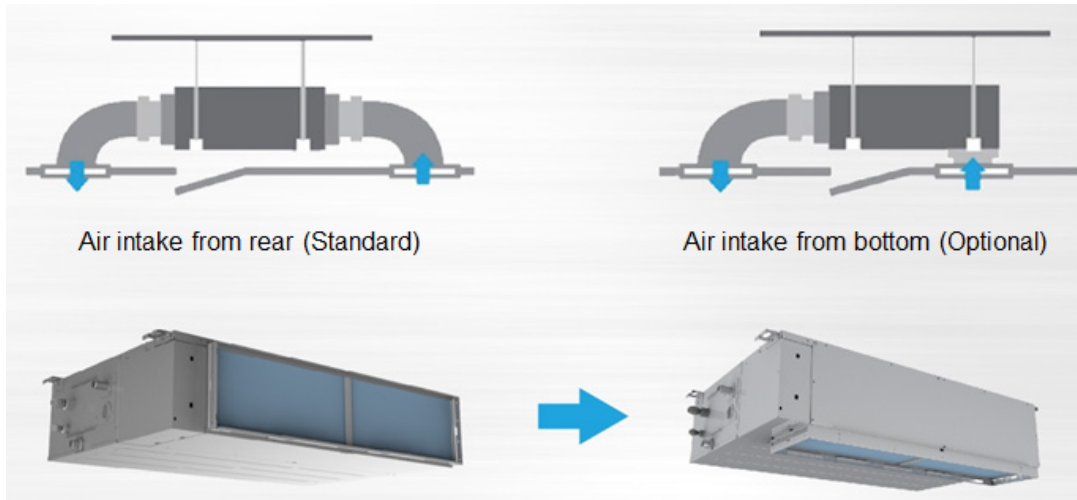

### 3.1.6 Built-in Drain Pump

The built-in drain pump can lift condensing water up to 750mm.

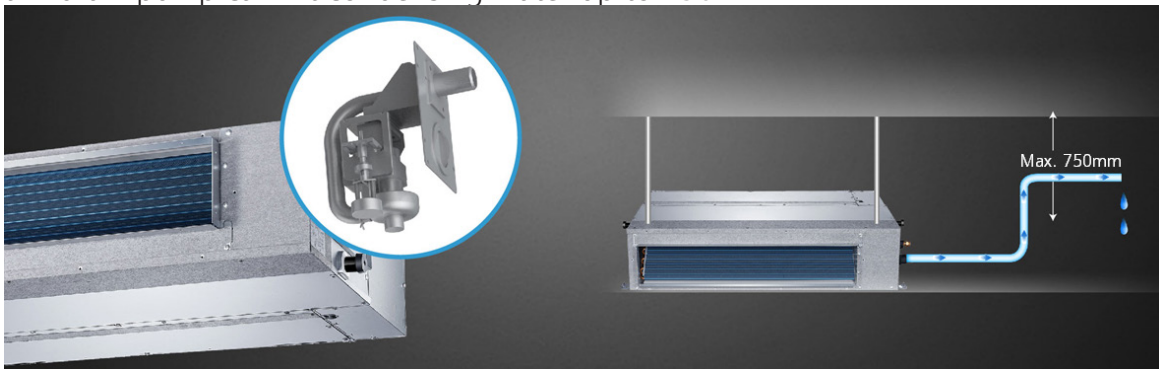

### 3.1.7 Easy Clean

You can pull out the filter from left, right, or from the bottom for easy cleaning.

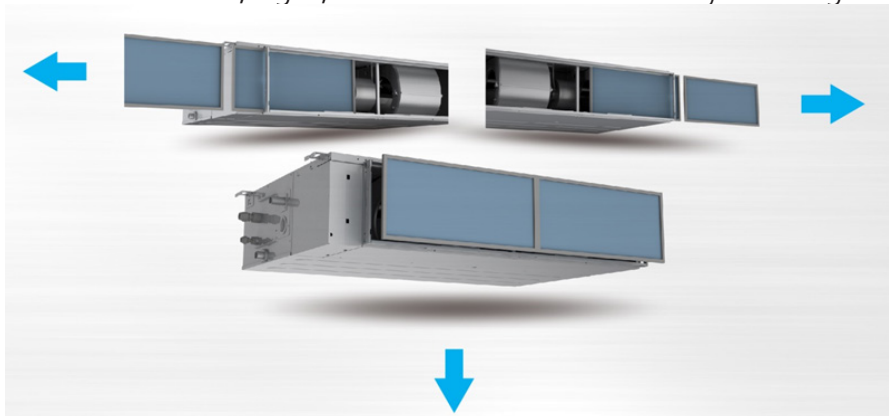

## 3.2 Compact Cassette Type

### 3.2.1 Compact design

- The body size is 570×260×570mm, it's just smaller than the ceiling board, so it's very easy for installation and will not damage the decoration. The panel size is 647×50×647mm.
- The hooks are designed in the four corners of the body, which can save installation space.

### 3.2.2 Fire-proof Controller Box

- Electrical control box adopts new design which can meet higher fire safety requirements.

### 3.2.3 Reserved remote on-off and alarm ports(Optional for fixed-speed units, standard for inverter units)

- Remote on-off: With the reserved ports, a remote switch can be easily connected to realize remote control.
- Alarm: The built-in PCB can output alarm signal, which achieve setting up an external alarm light or vibration gauge possible.



### 3.2.4 Build-in Drain Pump

- The drain pump can lift the condensed water up to 750mm.
- It's convenient to install drainage piping under most space condition.

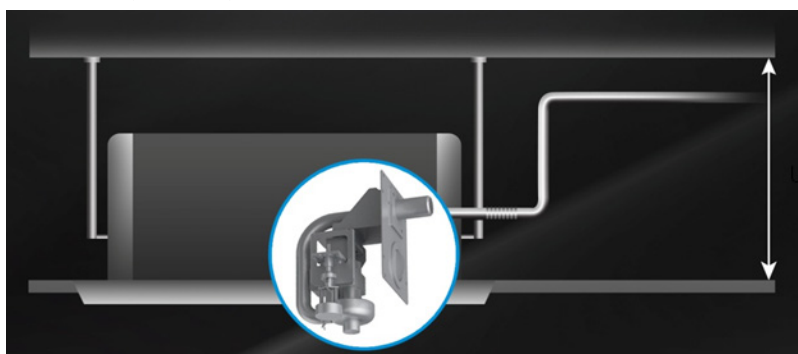

### 3.2.5 Fresh Air

- Fresh air intake function brings you fresh and comfortable air feeling.



### 3.2.6 Wired Controller(Optional)

- Compared with infrared remote controller, wired controller can be fixed on the wall and avoid mislaying. It's mainly used for commercial zone and makes air conditioner control more convenient.

## 3.3 Super-slim Cassette Type

### 3.3.1 360° Air Flow

- 360°directional wind can deliver air evenly throughout every corner in any space, reducing hot and cold spots in the room.

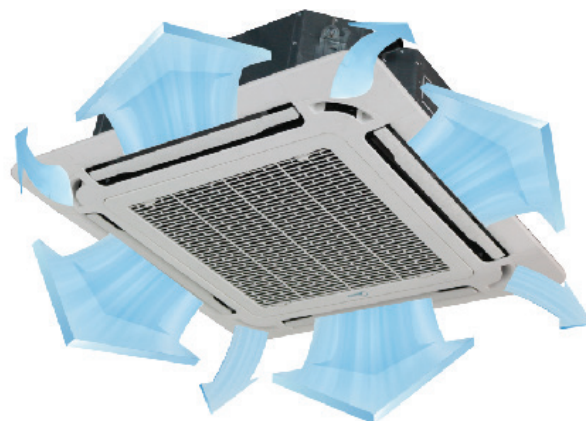

### 3.3.2 Independent Vane Control

- There are 4 air deflectors at each of sides with the cassette unit which enable it to change the air flow direction of any side independently as needed.

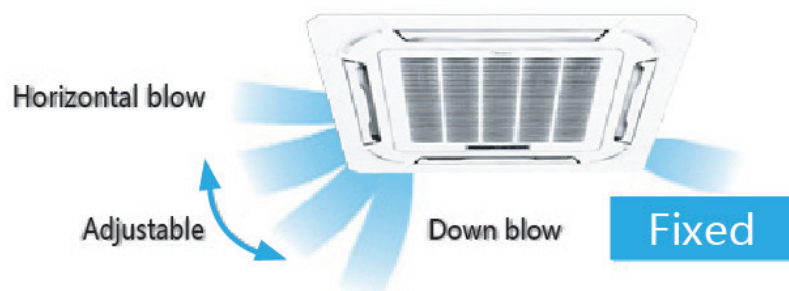

### 3.3.3 Easy Installation

- The Cassette is much slimmer due to the redesigned heat exchanger and overall structures. It now requires less space for installation.

### 3.3.4 Reserved Air Outlet for Duct

- The cassette unit is equipped with reserved connection for air outlet at the side of the indoor unit. It can connect to an air duct to cool a small room nearby.

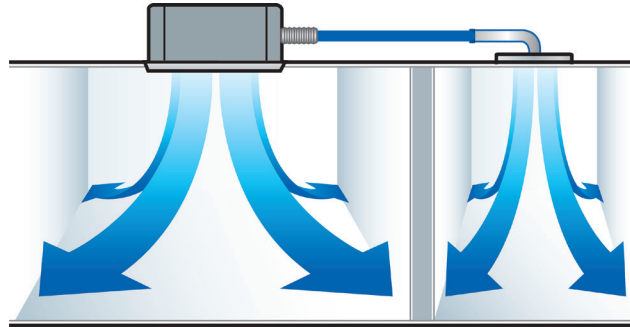

### 3.3.5 Reserved remote on-off and alarm ports (Optional for fixed-speed units, standard for inverter units)

- Remote on-off: With the reserved ports, a remote switch can be easily connected to realize remote control.
- Alarm: The built-in PCB can output alarm signal, which achieve setting up an external alarm light or vibration gauge possible.

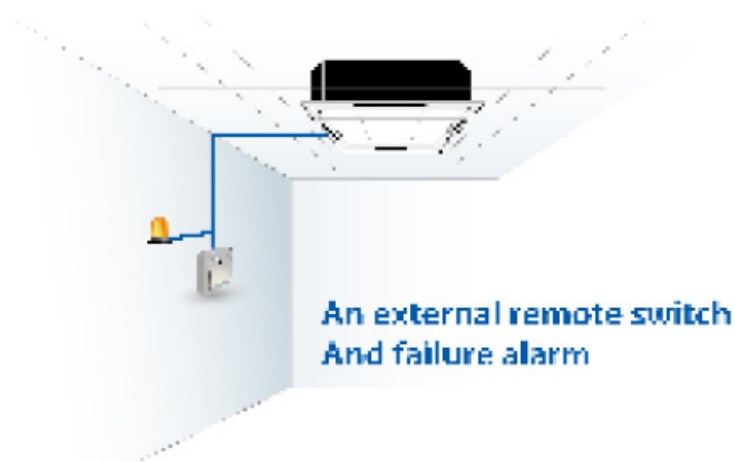

### 3.3.6 Build-in Drain Pump

- The drain pump can lift the condensed water up to 750mm. Which is convenient to install drainage pipes under most conditions. The drainage pipe can be installed on either the left or the right side.

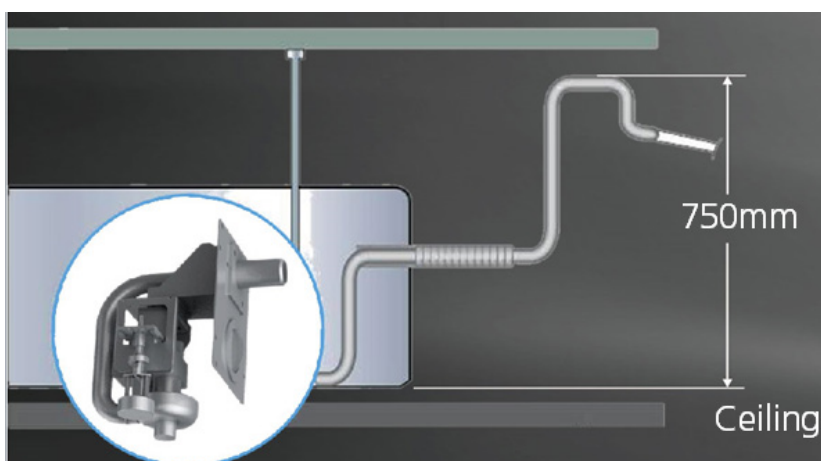

### 3.3.7 Fresh Air

- Fresh air intake function brings you fresh and comfortable air feeling.



### 3.3.8 Wired Controller(Optional)

- Compared with infrared remote controller, wired controller can be fixed on the wall and avoid mislaying. It's mainly used for commercial zone and makes air conditioner control more convenient.

## 3.4 Floor Ceiling Type

### 3.4.1 Easy installation-2 Style Installation

- Fashionable design and streamline appearance, suitable for different room style.

### 3.4.2 3D Airflow

- Vertical air flow and horizontal airflow can be adjusted by remote controller to direct air flow to every corner of the room.



### 3.4.3 Easy Maintenance-Universal Spare Parts

- More than 60% parts and assemblies (such as fan wheel, plastic cases, metal parts etc.) are universal for 3 different bodies, which makes maintenance much easier.

### 3.4.4 Fresh Air

- Fresh air intake function brings you fresh and comfortable air feeling.

### 3.4.5 Healthy Filters(Optional)

- Varies of healthy filters can be chosen to fix on the machine.

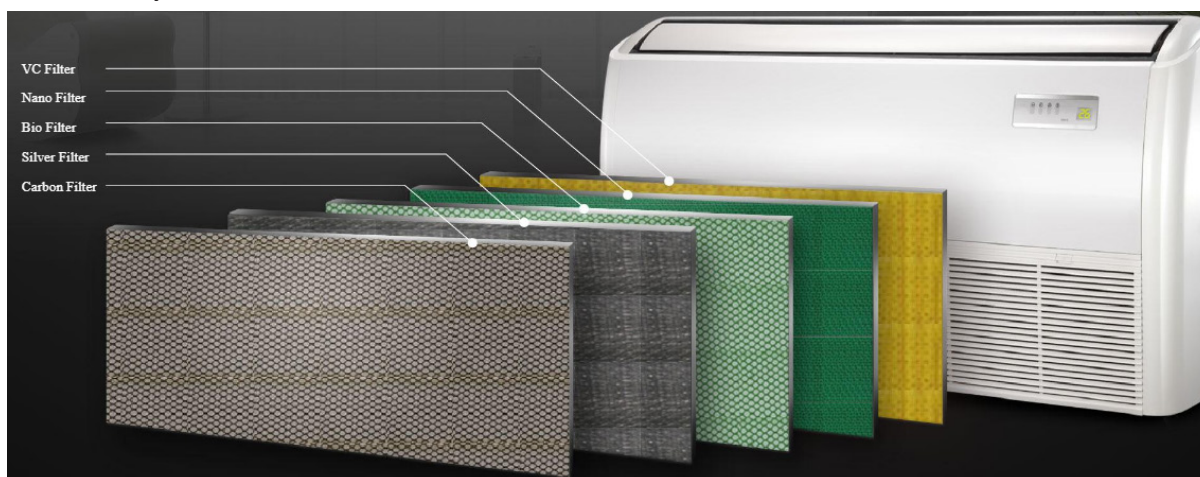

## 3.5 Wall Mounted Type(Aurora)

### 3.5.1 Powerful Cooling

- The optimized indoor and outdoor unit design improves cooling performance and generate a strong air flow as long as 12m and air speed  $\geq 0.3\text{m/s}$ , keeping your entire room cool all through the summer.

### 3.5.2 3D Air Flow

- The unit has horizontal swing and auto vertical swing function, which supplies more even and comfortable air flow.



### 3.5.3 Golden Fin

- The unique anticorrosive golden coating on the heat exchangers can withstand the salty air, rain and other corrosive elements. It also effectively prevents bacteria from breeding and improves heat efficiency.
- After one year of operation, the prototype with golden coating shows better performance in all working conditions than the prototype with blue coated foil.
- Dry-wet cycle tests 3000 times (equivalent to using an air conditioner for 10 years): the golden fin still has good hydrophilicity (hydrophilic angle  $\leq 30^\circ$ ).

### 3.5.4 Fireproof Electronic Control Box

- The electric control box uses ABS material with a 5VA flame retardant rating, and the outer surface is covered with sheet metal, which isolates the electric control box from fire.

### 3.5.5 ECO mode

- The air conditioner is equipped with the ECO energy-saving technology, which perfectly synergized with highly efficient inverter technology. You can indulge in comfortable coolness while significantly reducing energy consumption over 8 hours.



## 4. Part names of Indoor units

### A6 Duct Type

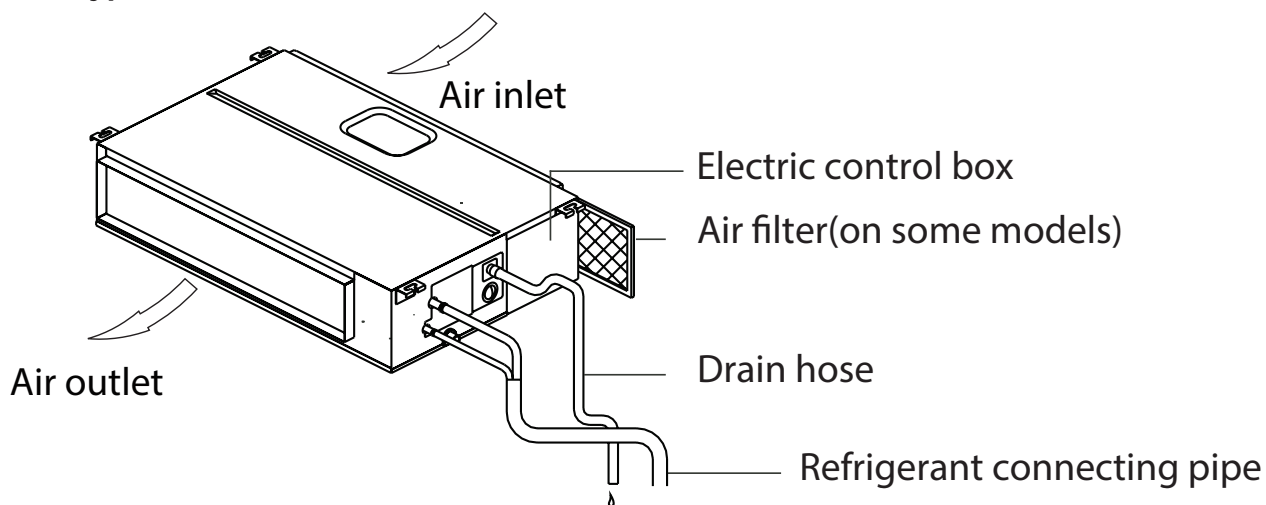

### Cassette Type

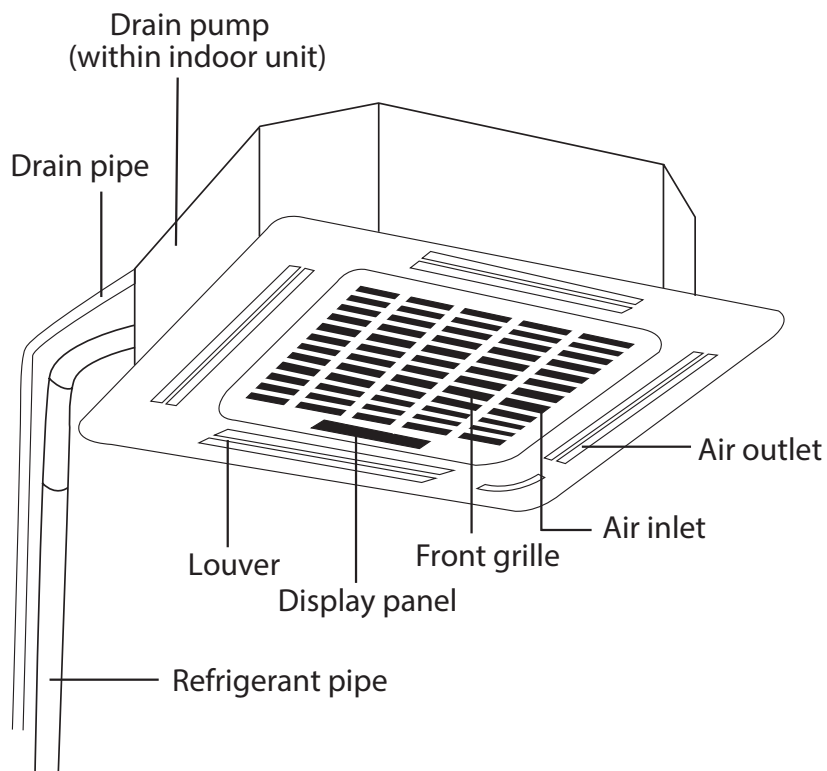



### Floor Ceiling Type

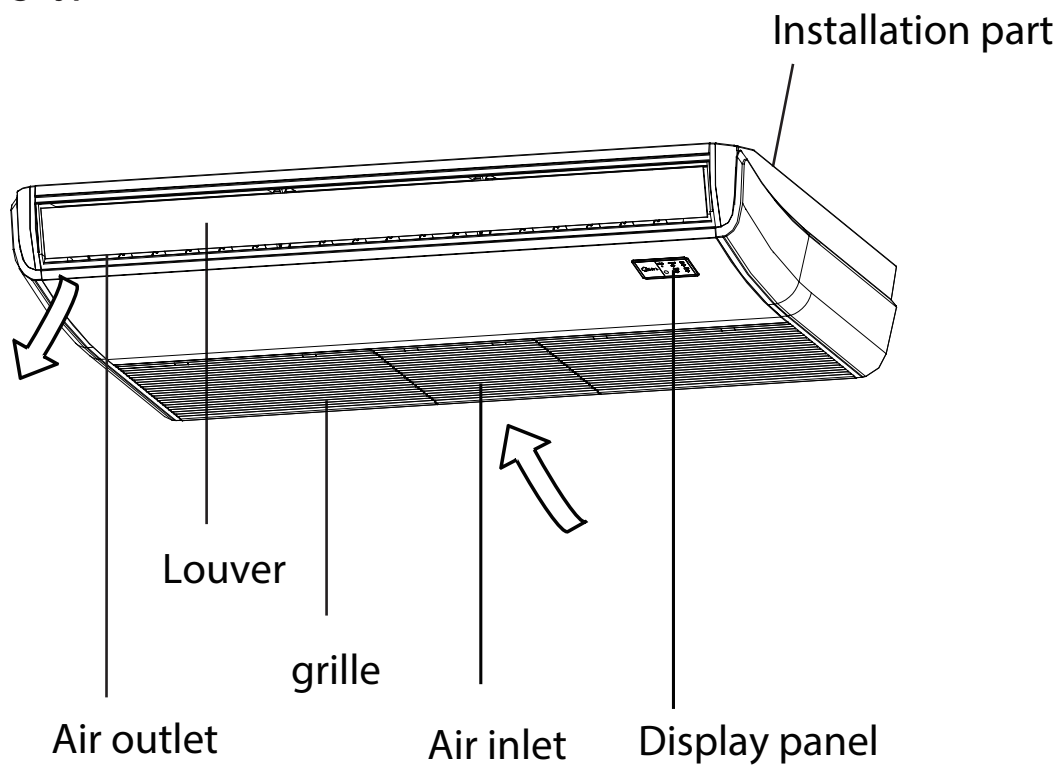

### Wall Mounted Type

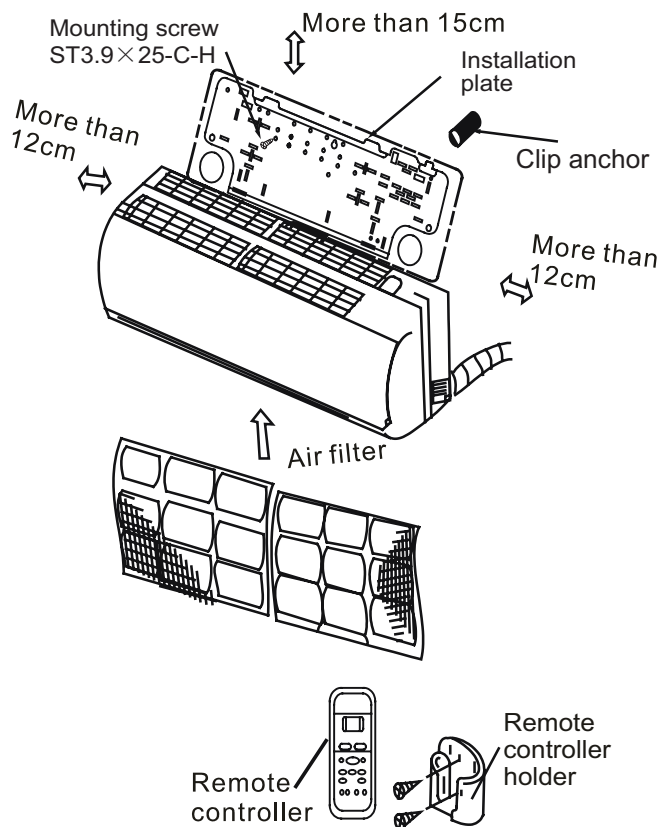

## 5. General Specifications

Indoor model			MTIU-09HWFN1-M	MTIU-12HWFN1-M	MTIU-18HWFN1-M	MTIU-24HWFN1-M
Power supply (Indoor )		V- Ph-Hz	208~230-1-60	208~230-1-60	208~230-1-60	208~230-1-60
Indoor fan motor	Model		ZKFN-55-8-22	ZKFN-55-8-22	ZKFN-160-8-1-2	ZKFN-160-8-1-2
	Qty		1	1	1	1
	Input	W	130.0	130.0	90.0	90.0
	Capacitor	uF	---	---	---	---
	Speed(Hi/Med/Lo)	r/min	1170/1030/850	1170/1030/850	850/700/450	880/820/690
Indoor coil	a.Number of rows		3	3	3	3
	b.Tube pitch(a)x row pitch(b)	mm	21x13.37	21x13.37	21x13.37	21x13.37
	c.Fin spacing	mm	1.4	1.4	1.4	1.4
	d.Fin type (code)		Hydrophilic aluminum	Hydrophilic aluminum	Hydrophilic aluminum	Hydrophilic aluminum
	e.Tube outside dia.and type	mm	Φ7 Inner groove tube	Φ7 Inner groove tube	Φ7 Inner groove tube	Φ7 Inner groove tube
	f.Coil length x height x width	mm	526x210x40.11	526x210x40.11	695x252x40.11	915x294x40.11
	g.Number of circuits		4	4	4	7
Indoor air flow (Hi/Med/Lo)		m3/h	600/480/300	600/480/300	900/765/630	1320/1180/740
ESP	Rated	Pa	25	25	25	25
	Range	Pa	0-40	0-40	0-100	0-160
Indoor noise level (Hi/Med/Lo)(Standard pressure)		dB(A)	38/32/25	38/33.5/26	39/37/35	44/41/34
Indoor unit	Dimension(W*D*H)	mm	700x506x200	700x506x200	880x674x210	1100x774x249
	Packing(W*D*H)	mm	860x540x275	860x540x275	1070x725x270	1305x805x305
	Net/Gross weight	Kg	17.7/21.9	17.8/22	23.8/29.5	39.4/46.7
Design pressure		MPa	4.2/1.5	4.2/1.5	4.2/1.5	4.2/1.5
Drainage water pipe dia.		mm	ODΦ25	ODΦ25	ODΦ25	ODΦ25
Refrigerant piping	Liquid side/ Gas side	mm(inch)	Φ6.35/Φ9.52(1/4"/3/8")	Φ6.35/Φ12.7(1/4"/1/2")	Φ6.35/Φ12.7(1/4"/1/2")	Φ9.52/Φ15.9(3/8"/5/8")
Controller			Wired Control	Wired Control	Wired control	Wired control
Operation temperature		°C	17~30	17~30	17~30	17~30
Room temperature	Cooling	°C	17~32	17~32	17~32	17~32
	Heating	°C	0~30	0~30	0~30	0~30
Qty/per 20' /40' /40'HQ			176/352/396	176/352/396	120/264/297	77/161/198

### Notes:

1) Capacities are based on the following conditions:

Cooling: - Indoor Temperature 26.7°C(80°F) DB /19.4 °C(67°F) WB

-Outdoor Temperature 35 °C(95°F) DB /23.9 °C(75°F) WB

-Interconnecting Piping Length 7.5m

- Level Difference of Zero.

Heating: - Indoor Temperature 21.1°C(70°F) DB / 15.6°C(60°F) WB

-Outdoor Temperature 8.3°C(47°F) DB / 6.1°C(43°F) WB

- Interconnecting Piping Length 7.5 m

- Level Difference of Zero.

2) Capacities are net capacities.

3) Due to our policy of innovation some specifications may be changed without notification.

Indoor model		MCA3U-09HRFN1-M(C)	MCA3U-12HRFN1-M(C)	MCA3U-18HRFN1-M(C)	MCDU-24HRFN1-M(C)	
Power supply (Indoor )		V- Ph-Hz	208~230-1-60	208~230-1-60	208~230-1-60	208~230-1-60
Indoor fan motor	Model		ZKFP-46-8-1	ZKFP-46-8-1	ZKFP-46-8-1	ZKFP-42-8-1
	Qty		1	1	1	1
	Input	W	45.0	45.0	45.0	58.0
	Capacitor	uF	---	---	---	---
	Speed(Hi/Med/Lo)	r/min	600/520/460	680/580/500	730/630/570	600/520/450
Indoor coil	a.Number of rows	3.0	1	2	2	2
	b.Tube pitch(a)x row pitch(b)	mm	21x13.37	21x13.37	21x13.37	21x13.37
	c.Fin spacing	mm	1.3	1.3	1.3	1.4
	d.Fin type (code)		Hydrophilic aluminum	Hydrophilic aluminum	Hydrophilic aluminum	Hydrophilic aluminum
	e.Tube outside dia.and type	mm	Φ7 Inner groove tube	Φ7 Inner groove tube	Φ7 Inner groove tube	Φ7 Inner groove tube
	f.Coil length x height x width	mm	1380x210x13.37	1360x210x26.74	1360x210x26.74	1940x168x26.74+ 2010x168x26.74
	g.Number of circuits		2	4	4	8
Indoor air flow (Hi/Med/Lo)		m3/h	600/520/460	574/490/422	956/825/746	1400/1250/1000
Indoor sound pressure level (Hi/Med/Lo)		dB(A)	41/39/37	41/38/35	46/43/41	51/47/43
Indoor unit	Dimension (W x Dx H)(body)	mm	570x570x260	570x570x260	570x570x260	840x840x205
	Packing (W x Dx H)(body)	mm	655x655x290	655x655x290	655x655x290	900x900x225
	Dimension (W x Dx H)(panel)	mm	647x647x50	647x647x50	647x647x50	950x950x55
	Packing (W x Dx H)(panel)	mm	715x715x123	715x715x123	715x715x123	1035x1035x90
	Net/Gross weight(body)	kg	14.5/17.3	16/18.6	16.2/21.3	21/24.6
	Net/Gross weight	kg	2.5/4.5	2.5/4.5	2.5/4.5	5/8
Design pressure		MPa	4.2/1.5	4.2/1.5	4.2/1.5	4.2/1.5
Drainage water pipe dia.		mm	ODΦ25	ODΦ25	ODΦ25	ODΦ32
Refrigerant piping	Liquid side/ Gas side	mm(inch)	Φ6.35/Φ9.52(1/4"/3/8")	Φ6.35/Φ12.7(1/4"/1/2")	Φ6.35/Φ12.7(1/4"/1/2")	Φ9.52/Φ15.9(3/8"/5/8")
Controller			Remote Control	Remote Control	Remote Control	Remote control
Operation temperature		°C	17~30	17~30	17~30	17~30
Room temperature	Cooling	°C	17~32	17~32	17~32	17~32
	Heating	°C	0~30	0~30	0~30	0~30
Qty'per 20' /40' /40'HQ			186/375/429	186/375/429	186/375/429	148/312/342

## Notes:

## 1) Capacities are based on the following conditions:

Cooling: - Indoor Temperature 26.7°C(80°F) DB /19.4 °C(67°F) WB      Heating: - Indoor Temperature 21.1°C(70°F) DB / 15.6°C(60°F) WB  
 -Outdoor Temperature 35 °C(95°F) DB /23.9 °C(75°F) WB      -Outdoor Temperature 8.3°C(47°F) DB / 6.1°C(43°F) WB  
 -Interconnecting Piping Length 7.5m      - Interconnecting Piping Length 7.5 m  
 - Level Difference of Zero.      - Level Difference of Zero.

## 2) Capacities are net capacities.

## 3) Due to our policy of innovation some specifications may be changed without notification.

Indoor model			MUEU-18HRFN1-M(C)	MUBU-24HRFN1-M(C)
Power supply (Indoor )		V- Ph-Hz	208~230-1-60	208~230-1-60
Indoor fan motor	Model		ZKFN-55-8-1	ZKFN-55-8-1
	Qty		1	1
	Input	W	100.0	100.0
	Capacitor	uF	---	---
	Speed(Hi/Med/Lo)	r/min	950/850/750	1350/1260/1120
Indoor coil	a.Number of rows		2	3
	b.Tube pitch(a)x row pitch(b)	mm	21x13.37	21x13.37
	c.Fin spacing	mm	1.3	1.3
	d.Fin type (code)		Hydrophilic aluminum	Hydrophilic aluminum
	e.Tube outside dia.and type	mm	Φ7 Inner groove tube	Φ7 Inner groove tube
	f.Coil length x height x width	mm	795x294x26.74	795x294x40.11
	g.Number of circuits		6	7
Indoor air flow (Hi/Med/Lo)		m <sup>3</sup> /h	932/825/715	1290/1204/1017
Indoor noise level (Hi/Med/Lo)		dB(A)	47/44/39	58.5/55/52
Indoor unit	Dimension(W*D*H)	mm	1068x675x235	1068x675x235
	Packing(W*D*H)	mm	1145x755x313	1145x755x313
	Net/Gross weight	Kg	25.9/31	26.5/31.4
Design pressure		MPa	4.2/1.5	4.2/1.5
Drainage water pipe dia.		mm	ODΦ25	ODΦ25
Refrigerant piping	Liquid side/ Gas side	mm(inch)	Φ6.35/Φ9.52(1/4"/3/8")	Φ9.52/Φ15.9(3/8"/5/8")
Controller			Wired Control	Wired control
Operation temperature		°C	17~30	17~30
Room temperature	Cooling	°C	17~32	17~32
	Heating	°C	0~30	0~30
Qty/per 20' /40' /40'HQ			102/220/252	102/220/252

## Notes:

## 1) Capacities are based on the following conditions:

Cooling: - Indoor Temperature 26.7°C(80°F) DB /19.4 °C(67°F) WB

-Outdoor Temperature 35 °C(95°F) DB /23.9 °C(75°F) WB

-Interconnecting Piping Length 7.5m

- Level Difference of Zero.

Heating: - Indoor Temperature 21.1°C(70°F) DB / 15.6°C(60°F) WB

-Outdoor Temperature 8.3°C(47°F) DB / 6.1°C(43°F) WB

- Interconnecting Piping Length 7.5 m

- Level Difference of Zero.

## 2) Capacities are net capacities.

## 3) Due to our policy of innovation some specifications may be changed without notification.

Indoor model		MSABB-09HRFN1-MTOW	MSABB-12HRFN1-MTOW	MSABE-18HRFN1-MTOW	MSABE-24HRFN1-MTOW	
Power supply (Indoor )		V- Ph-Hz	208~230-1-60	208~230-1-60	208~230-1-60	208~230-1-60
Indoor fan motor	Model		ZKFP-20-8-6-7	ZKFP-20-8-6-7	ZKFP-58-8-1	ZKFP-58-8-1
	Brand		Welling	Welling	Welling	Welling
	Input	W	50	50	58	58
	RLA	A	0.25	0.25	0.4	0.45
	LRA	A	----	----	----	----
	Winding Resistance	Ω	----	----	----	----
	Capacitor	uF	----	----	----	----
	Speed(Hi/Med/Lo)	r/min	1100/800/700	1100/850/700	1000/800/700	1100/900/700
Indoor coil	a.Number of rows	3.0	2	2	2	2
	b.Tube pitch(a)x row pitch(b)	mm	21x13.37	21x13.37	21x13.37	21x13.37
	c.Fin spacing	mm	1.3	1.3	1.3	1.3
	d.Fin type (code)		Hydrophilic aluminum	Hydrophilic aluminum	Hydrophilic aluminum	Hydrophilic aluminum
	e.Tube outside dia.and type	mm	Φ7 Inner groove tube	Φ7 Inner groove tube	Φ7 Inner groove tube	Φ7 Inner groove tube
	f.Coil length x height x width	mm	605x210x26.74+605x84x26.74	605x210x26.74+605x84x26.74	820x210x26.74+820x126x26.74	820x210x26.74+820x126x26.74
	g.Number of circuits		2	2	4	4
Indoor air flow (Hi/Med/Lo)		m <sup>3</sup> /h	450/350/240	520/360/250	950/620/520	1050/800/550
Indoor sound pressure level (Hi/Med/Lo)		dB(A)	41/37/28	39/32/25	45.5/40/34.5	50/43/35.5
Indoor unit	Dimension(W*D*H)	mm	802x297x189	802x297x189	1080x335x226	1080x335x226
	Packing (W*D*H)	mm	875x375x285	875x375x285	1155x315x415	1155x315x415
	Net/Gross weight	Kg	8.4/11	8.5/11	13.4/17.1	13.1/16.5
Design pressure		MPa	4.2/1.5	4.2/1.5	4.2/1.5	4.2/1.5
Refrigerant piping	Liquid side/ Gas side	mm(inch)	Φ6.35/Φ9.52(1/4"/3/8")	Φ6.35/Φ12.7(1/4"/1/2")	Φ6.35/Φ12.7(1/4"/1/2")	Φ9.52/Φ15.9(3/8"/5/8")
Controller			Remote Control	Remote Control	Remote Control	Remote control
Operation temperature		°C	17~30	17~30	17~30	17~30
Room temperature	Cooling	°C	17~32	17~32	17~32	17~32
	Heating	°C	0~30	0~30	0~30	0~30
Qty'per 20' /40' /40'HQ			300/630/720	300/630/720	195/400/464	195/400/464

## Notes:

1) Capacities are based on the following conditions:

Cooling: - Indoor Temperature 26.7°C(80°F) DB /19.4 °C(67°F) WB      Heating: - Indoor Temperature 21.1°C(70°F) DB / 15.6°C(60°F) WB  
 -Outdoor Temperature 35 °C(95°F) DB /23.9 °C(75°F) WB                      -Outdoor Temperature 8.3°C(47°F) DB / 6.1°C(43°F) WB  
 -Interconnecting Piping Length 7.5m    - Interconnecting Piping Length 7.5 m  
 - Level Difference of Zero.    - Level Difference of Zero.

2) Capacities are net capacities.

3) Due to our policy of innovation some specifications may be changed without notification.

Outdoor model			M2OF-18HFN1-M	M3OF-27HFN1-M	M4OF-36HFN1-M	M5OF-48HFN1-M
Power Supply (Outdoor)		V-Ph-Hz	208~230-1-60	208~230-1-60	208~230-1-60	208~230-1-60
Max. input consumption		W	3030	3550	4600	5550
Max. current		A	14.5	17	21.5	26.5
Compressor	Model		ATM150D23UFZ	ATF235D22UMT	ATF310D43UMT	ATQ360D1UMU
	Type		ROTARY	ROTARY	ROTARY	ROTARY
	Brand		GMCC	GMCC	GMCC	GMCC
	Capacity	Btu/h	4510	7135	9490	11200
	Input	W	1170	1970	2600	3040
	Rated current(RLA)	A	8.1	6.95	5.1	5.9
	Locked rotor Amp(LRA)	A	/	/	/	/
	Thermal protector position		NA	NA	NA	NA
	Capacitor	µF	/	/	/	/
Refrigerant oil	ml	VG74/500	VG74/670	VG74/1000	VG74/1400	
Outdoor fan motor	Model		ZKFN-50-8-2	ZKFN-120-8-2	ZKFN-120-8-2	ZKFN-85-8-22
	Qty		1.0	1.0	1.0	2.0
	Input	W	115.0	150.0	150.0	126.0
	Capacitor	µF	/	/	/	/
	Speed	r/min	800/650/550	900/750/600	900/750/600	800/700/600
Outdoor coil	Number of rows		2.0	1.6	2.0	2.0
	Tube pitch(a)x row pitch(b)	mm	25.4x22	25.4x22	25.4x22	25.4x22
	Fin spacing	mm	1.4	1.3	1.3	1.4
	Fin type (code)		Hydrophilic aluminum	Hydrophilic aluminum	Hydrophilic aluminum	Hydrophilic aluminum
	Tube outside dia.and type	mm	Φ9.52,Inner groove tube	Φ9.52,Inner groove tube	Φ9.52,Inner groove tube	Φ9.52,Inner groove tube
	Coil length x height x width	mm	730x660x44	1005x762x22+580x762x22	995x762x44	990x1270x44
Number of circuits		4	4	4	8	
Outdoor air flow		m <sup>3</sup> /h	1390	3620	3650	7650
Outdoor sound pressure level		dB(A)	58	61.5	62.5	63
Throttle type			Capillary+EXV	Capillary+EXV	Capillary+EXV	Capillary+EXV
Outdoor unit	Dimension(W*D*H)	mm	845x702x363	946x810x410	946x810x410	952x1333x415
	Packing (W*D*H)	mm	965x775x395	1090x885x500	1090x885x500	1095x1480x495
	Net/Gross weight	Kg	48/52	69/73	71/76	101.5/115.7
Refrigerant type	Type	-	R410A	R410A	R410A	R410A
	Charged quantity	Kg	70.5	98.8	105.8	162
Design pressure		MPa	4.2/1.5	4.2/1.5	4.2/1.5	4.2/1.5
Refrigerant piping	Liquid side/ Gas side	mm(inch)	2 x Φ6.35/Φ9.52(1/4"/3/8")	3 x Φ6.35/Φ9.52(1/4"/3/8")	4 x Φ6.35/3x Φ9.52+1xΦ12.7 (4x1/4"/3x3/8"+1x1/2")	5 x Φ6.35/3x Φ9.52+2xΦ12.7(5x1/4"/3x3/8"+2x1/2")
	Max. length for all rooms	m	40	60	80	80
	Max. length for one indoor unit	m	25	30	35	35
	Max. height difference between indoor and outdoor unit	m	15	15	15	15
	Max. height difference between indoor units	m	10	10	10	10
Ambient temperature	Cooling	°C	-15~50	-15~50	-15~50	-15~50
	Heating	°C	-15~24	-15~24	-15~24	-15~24

## Notes:

1) Capacities are based on the following conditions:

Cooling: - Indoor Temperature 26.7°C(80°F) DB /19.4 °C(67°F) WB

-Outdoor Temperature 35 °C(95°F) DB /23.9 °C(75°F) WB

-Interconnecting Piping Length 7.5m

- Level Difference of Zero.

Heating: - Indoor Temperature 21.1°C(70°F) DB / 15.6°C(60°F) WB

-Outdoor Temperature 8.3°C(47°F) DB / 6.1°C(43°F) WB

- Interconnecting Piping Length 7.5 m

- Level Difference of Zero.

2) Capacities are net capacities.

3) Due to our policy of innovation some specifications may be changed without notification.

## 6. Indoor Unit Combination

Multi DC Outdoor Unit		Nominal capacity	Suggested Combination
			Two units
1 drive 2	M20F-18HFN1-M	5.2kW	9+9
			9+12
			12+12

Multi DC Outdoor Unit		Nominal capacity	Suggested Combination	
			Two units	Three units
1 drive 3	M30F-27HFN1-M	7.8kW	9+9	9+9+9
			9+12	9+9+12
			9+18	9+9+18
			12+12	9+12+12
			12+18	12+12+12
			18+18	

Multi DC Outdoor Unit		Nominal capacity	Suggested Combination		
			Two units	Three units	Four units
1 drive 4	M40F-36HFN1-M	10.5kW	9+9	9+9+9	9+9+9+9
			9+12	9+9+12	9+9+9+12
			9+18	9+9+18	9+9+9+18
			9+24	9+12+12	9+9+12+12
			12+12	9+12+18	9+9+12+18
			12+18	9+18+18	9+12+12+12
			12+24	12+12+12	12+12+12+12
			18+18	12+12+18	
				12+18+18	
				12+12+24	

Multi DC Outdoor Unit		Nominal capacity	Suggested Combination			
			Two units	Three units	Four units	Five units
1 drive 5	M50F-48HFN1-M	14kW	9+18	9+9+9	9+9+9+9	9+9+9+9+9
			9+24	9+9+12	9+9+9+12	9+9+9+9+12
			12+12	9+9+18	9+9+9+18	9+9+9+9+18
			12+18	9+9+24	9+9+9+24	9+9+9+9+24
			12+24	9+12+12	9+9+12+12	9+9+9+12+12
			18+18	9+12+18	9+9+12+18	9+9+9+12+18
			18+24	9+12+24	9+9+12+24	9+9+9+18+18
			24+24	9+18+18	9+9+18+18	9+9+12+12+12
				9+18+24	9+9+18+24	9+9+12+12+18
				9+24+24	9+12+12+12	9+12+12+12+12
				12+12+12	9+12+12+18	9+12+12+12+18
				12+12+18	9+12+12+24	12+12+12+12+12
				12+12+24	9+12+18+18	
				12+18+18	9+18+18+18	
				12+18+24	12+12+12+12	
				12+24+24	12+12+12+18	
				18+18+18	12+12+12+24	
	18+18+24	12+12+18+18				

## 7. Dimensional Drawings

### 7.1 Indoor Unit

#### A6 Duct type

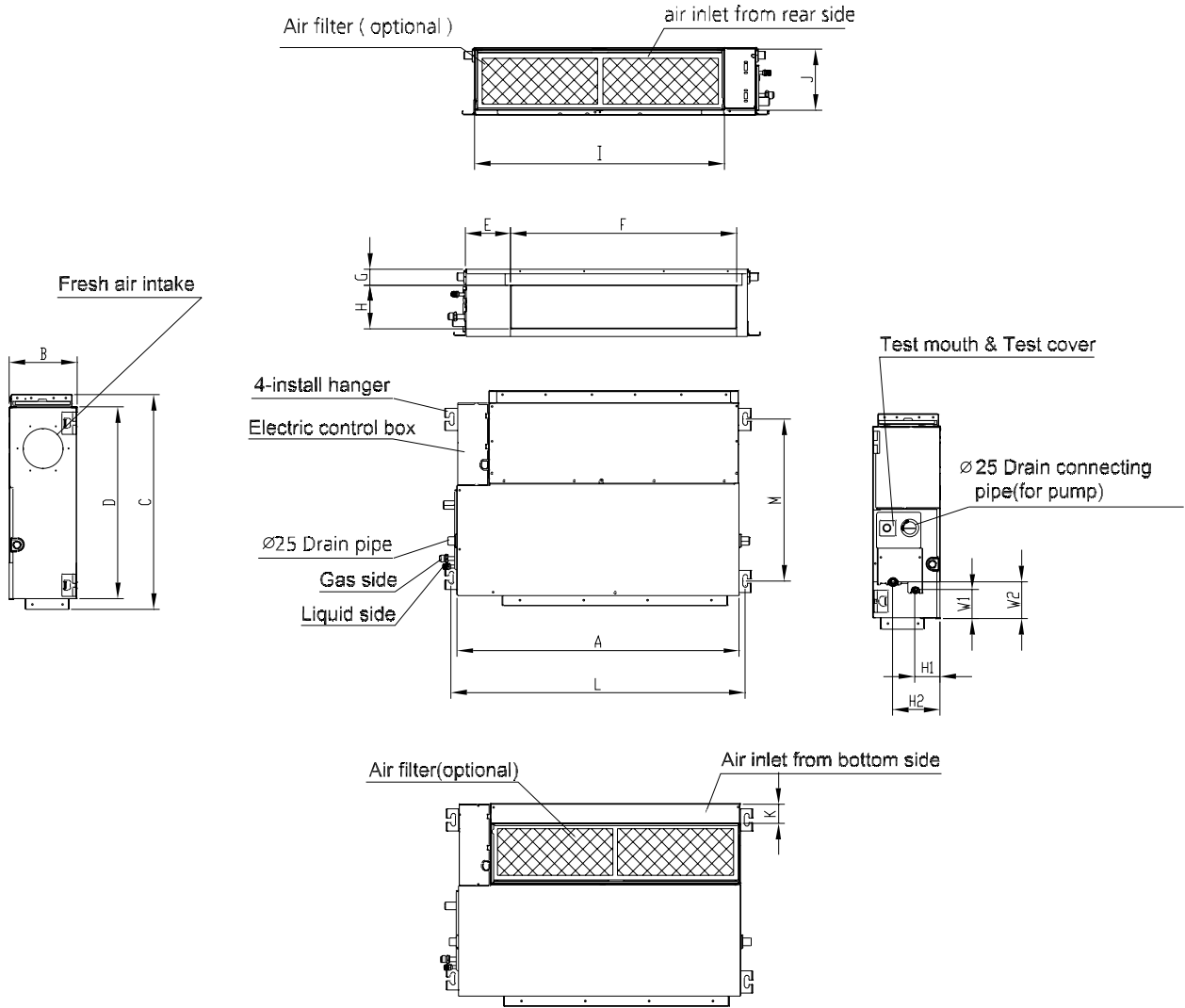

Capacity (kBtu/h)	unit	A	B	C	D	E	F	G	H	I	J	K	L	M	H1	H2	W1	W2
9/12	mm	700	200	506	450	137	537	30	152	599	186	50	741	360	84	140	84	84
	inch	27.56	7.87	19.92	17.72	5.39	21.14	1.18	5.98	23.58	7.32	1.97	29.17	14.17	3.31	5.51	3.31	3.31
18	mm	880	210	674	600	140	706	50	136	782	190	40	920	508	78	148	88	112
	inch	34.65	8.27	26.54	23.62	5.51	27.8	1.97	5.35	30.79	7.48	1.57	36.22	20	3.07	5.83	3.46	4.41
24	mm	1100	249	774	700	140	926	50	175	1001	228	5	1140	598	80	150	130	155
	inch	43.31	9.8	30.47	27.56	5.51	36.46	1.97	6.89	39.41	8.98	0.2	44.88	23.54	3.15	5.91	5.12	6.1



## Compact Cassette type

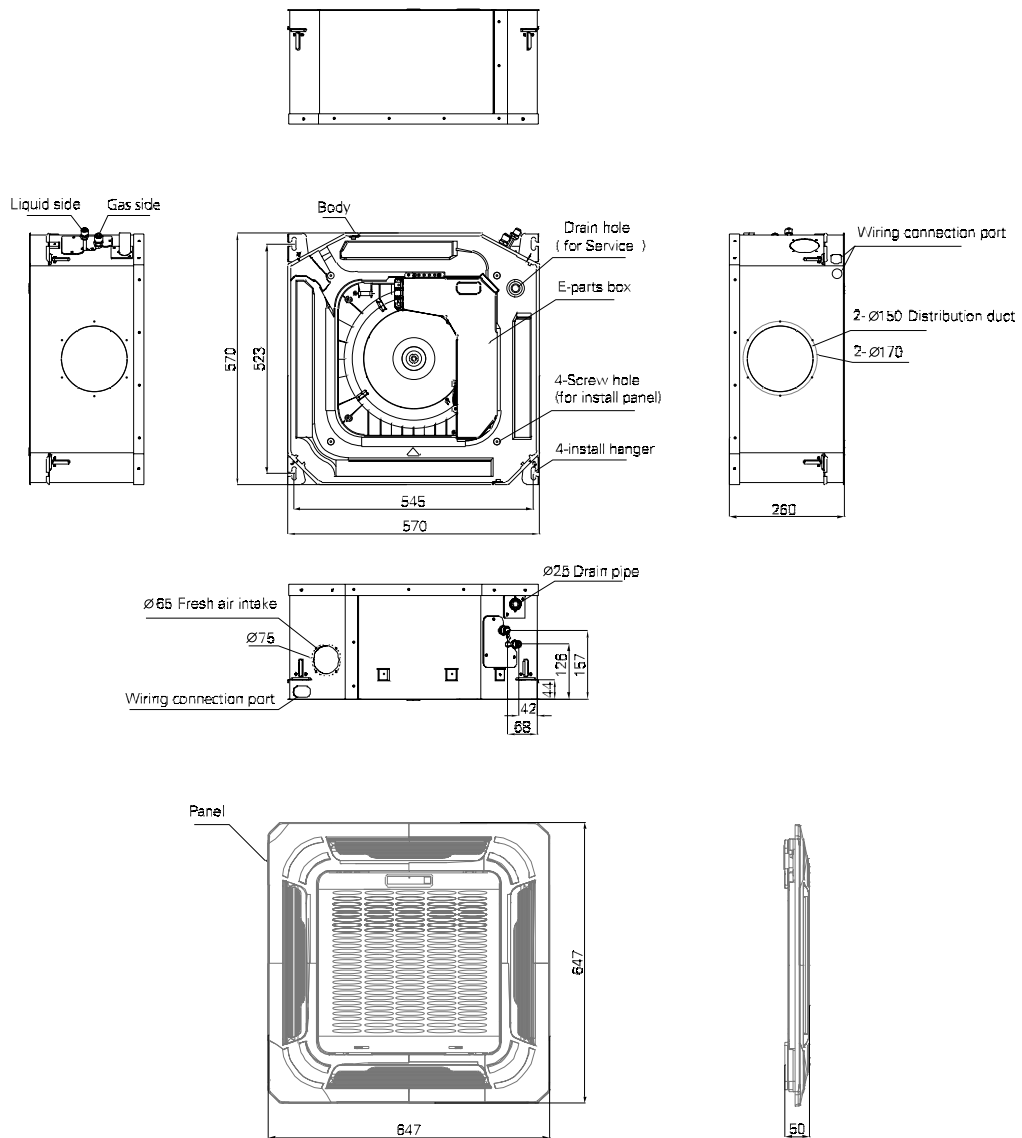

# Super Slim Cassette

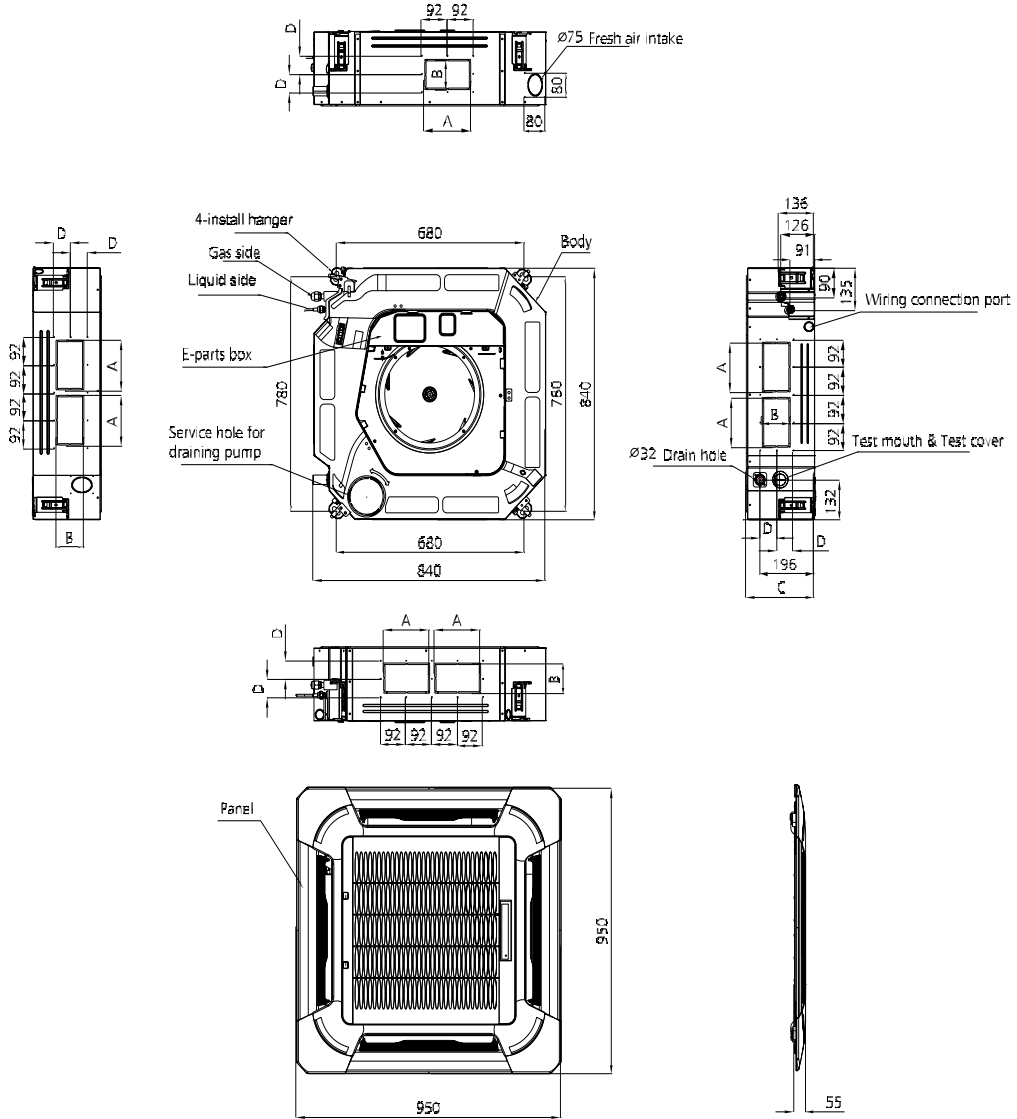

Model(KBtu/h)	Unit	A	B	C	D
24	mm	160	75	205	50
	inch	6.3	2.95	8.07	1.97

## Floor Ceiling type

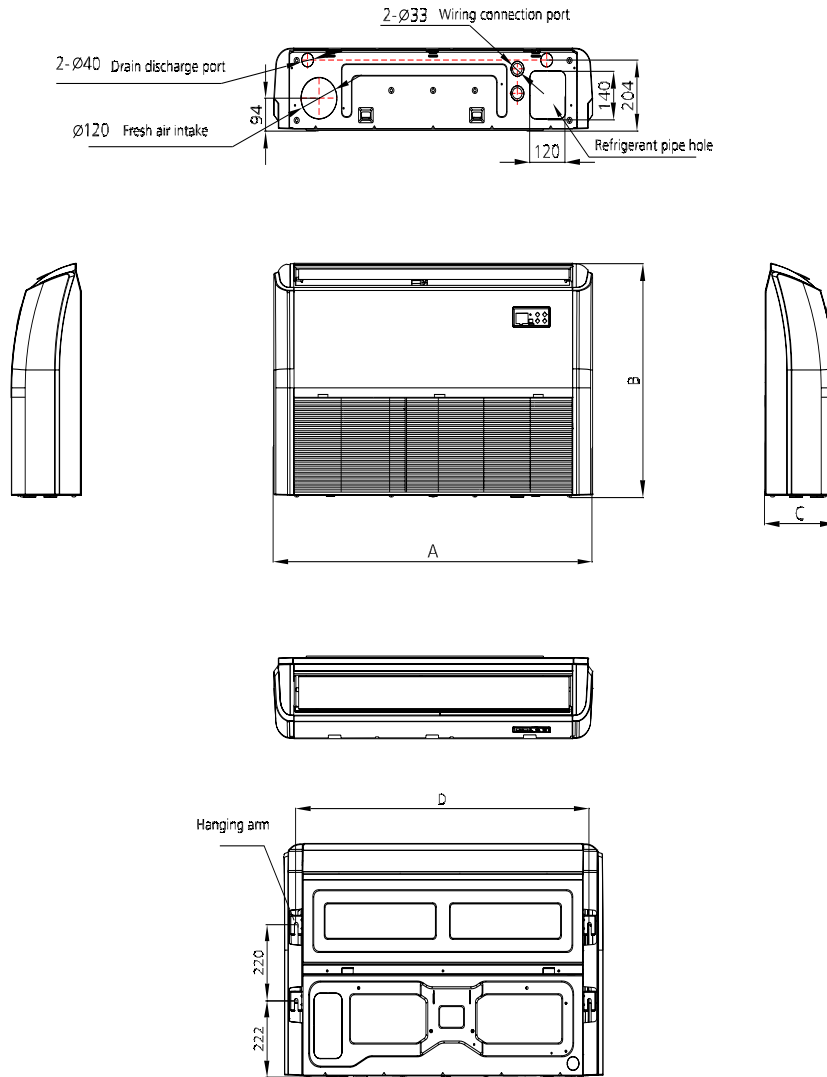

Model(KBtu/h)	Unit	A	B	C	D
18-24	mm	1068	675	235	983
	inch	42.05	26.57	9.25	38.7

Wall mounted type

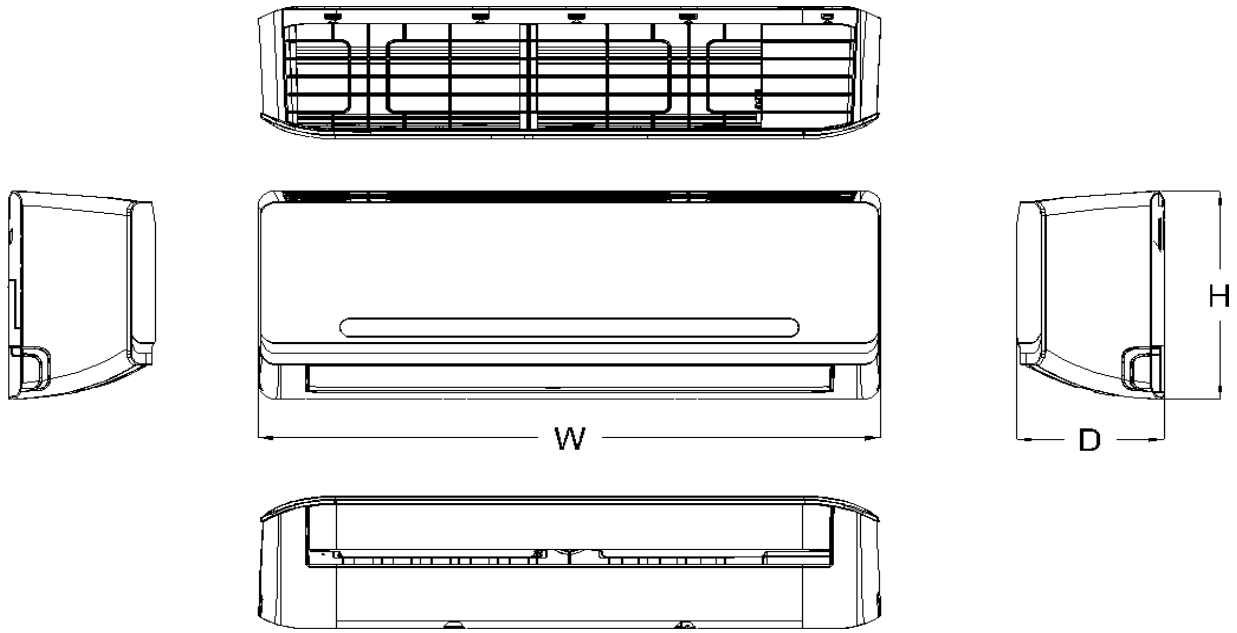

Model(kBtu/h)	W(mm)	D(mm)	H(mm)
9/12	802	189	297
18/24	1080	226	335

## 7.2 Outdoor Unit

Single Fan Outdoor Unit

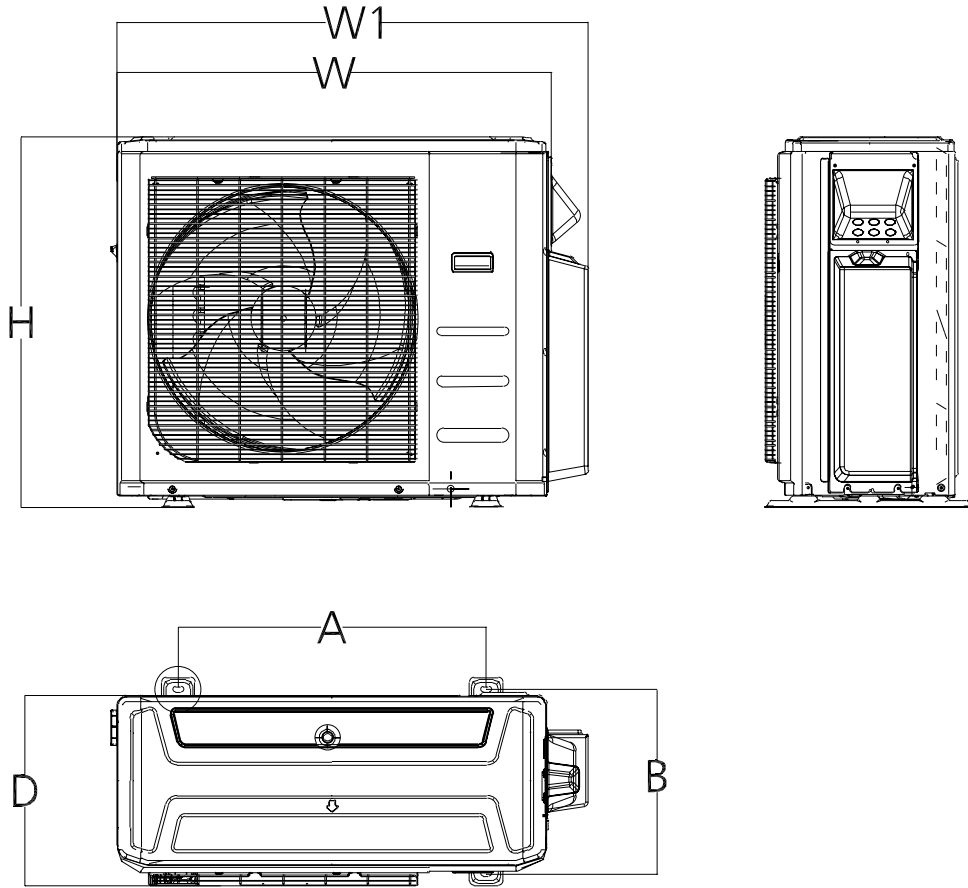

Model	unit	W	D	H	W1	A	B
M2OF-18HFN1-M	mm	845	363	702	923	540	350
	inch	33.27	14.29	27.64	36.3	21.26	13.78
M3OF-27HFN1-M M4OF-36HFN1-M	mm	946	410	810	1034	673	403
	inch	37.24	16.14	31.89	40.7	26.50	15.87

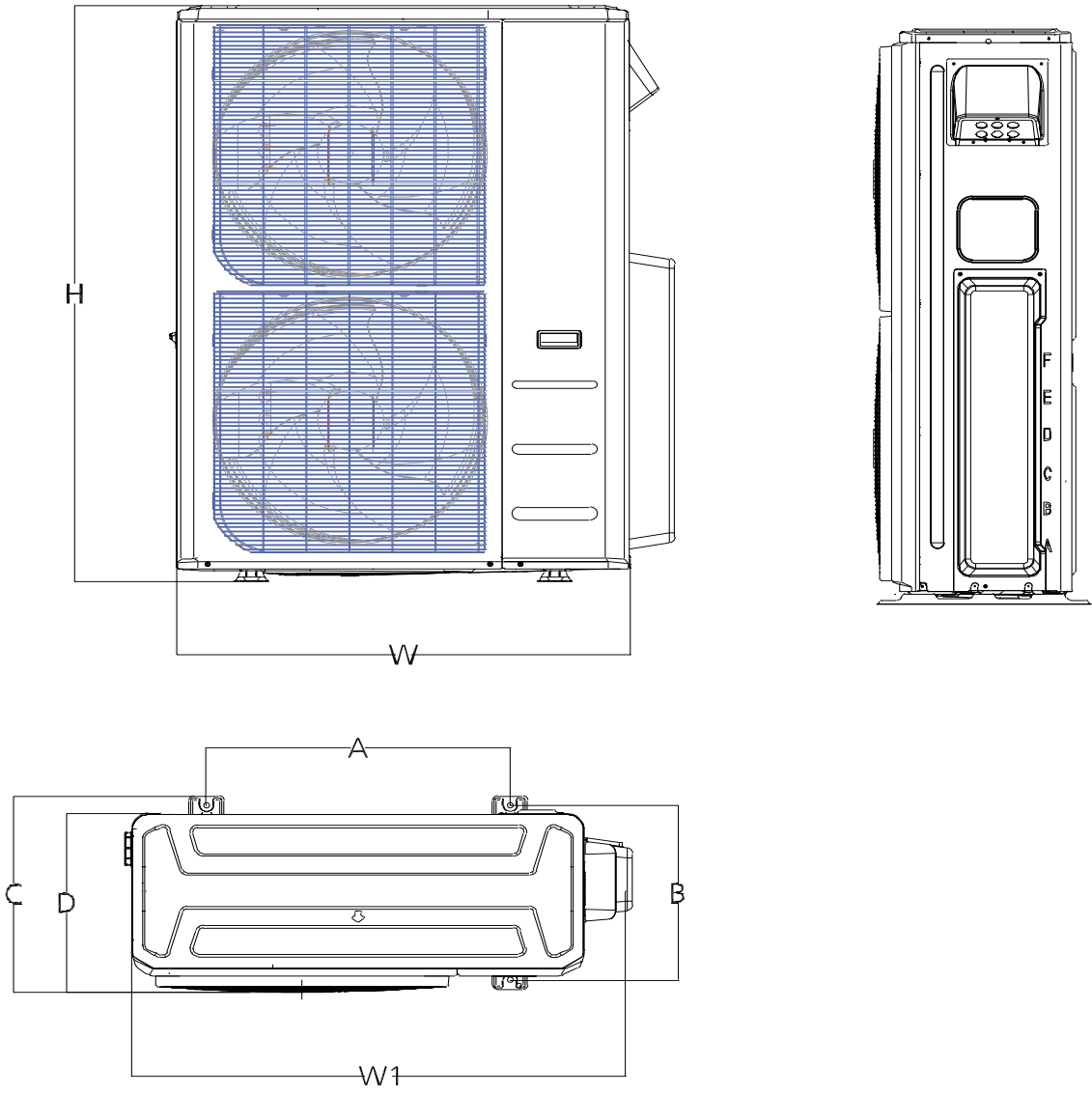

Model	Unit	W	D	H	W1	A	B	C
M5OF-48HFN1-M	mm	952	415	1333	1060	634	404	457
	inch	37.48	16.34	52.48	41.7	24.96	15.9	17.99

## 8. Centre of gravity

M2OF-18HFN1-M

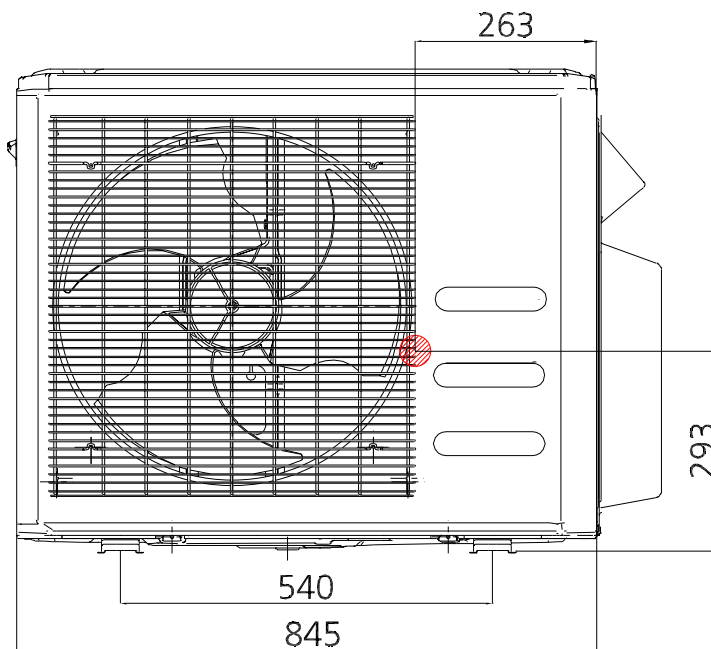
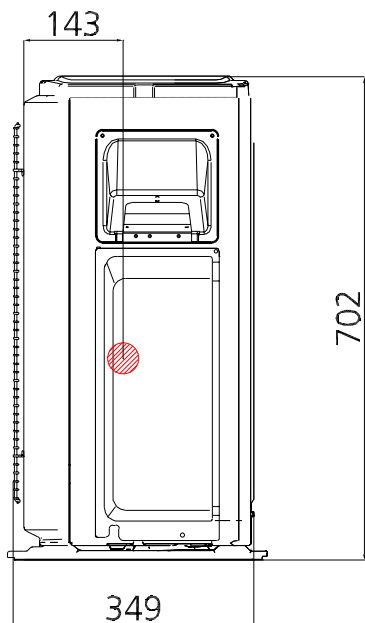

M3OF-27HFN1-M, M4OF-36HFN1-M

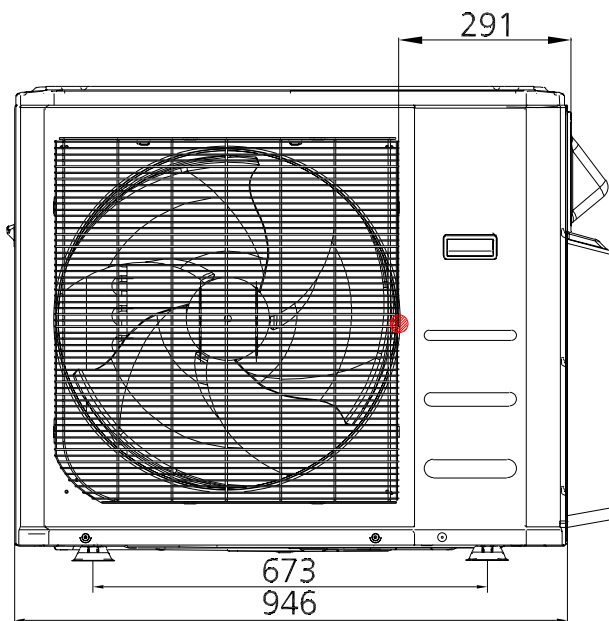
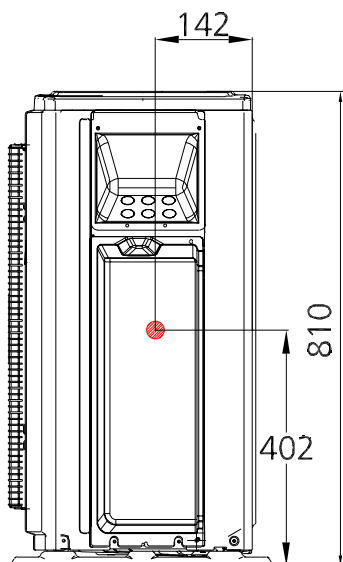

M5OF-48HFN1-M

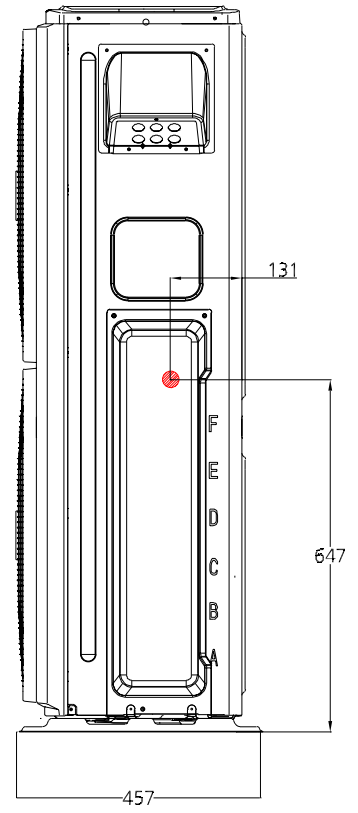
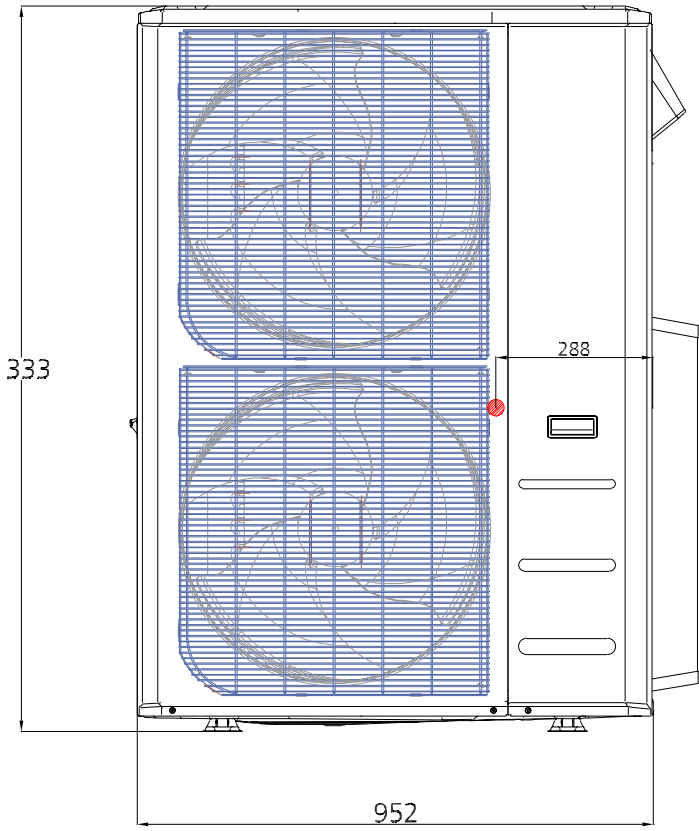



## 9. Air Velocity and Temperature Distributions

Compact Cassette type -9k &12k

Discharge Angle 30°

Cooling airflow velocity distributions

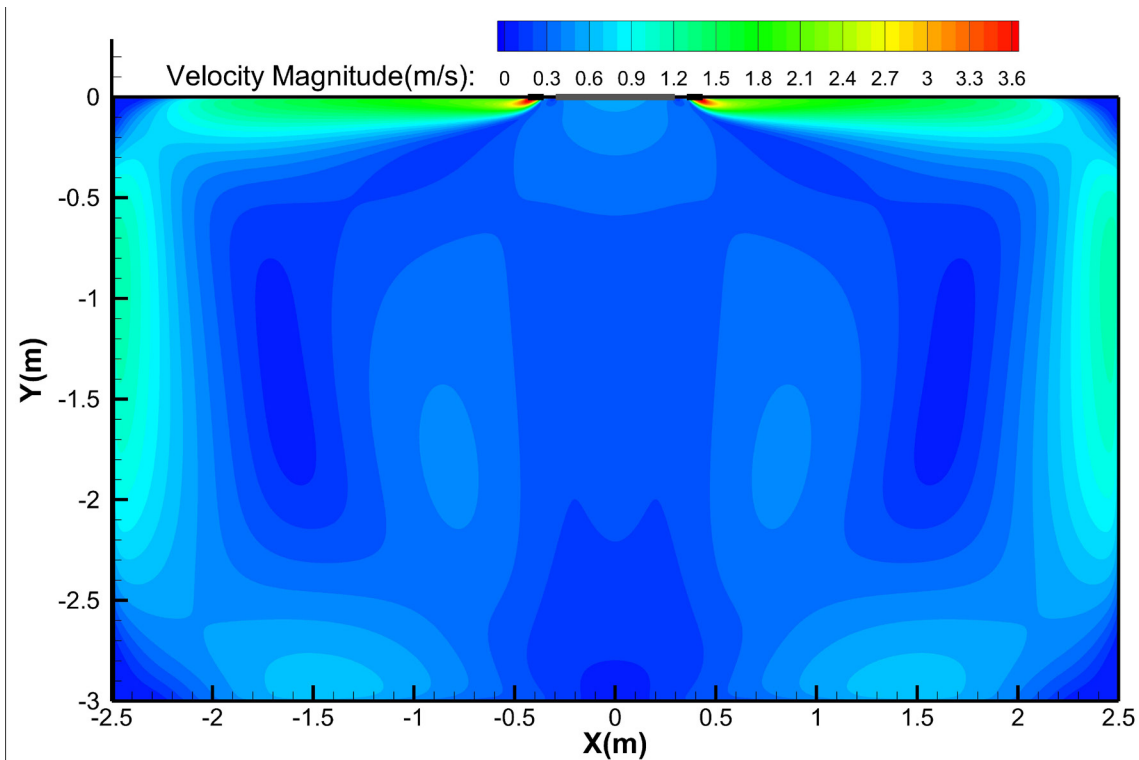

Cooling temperature distributions

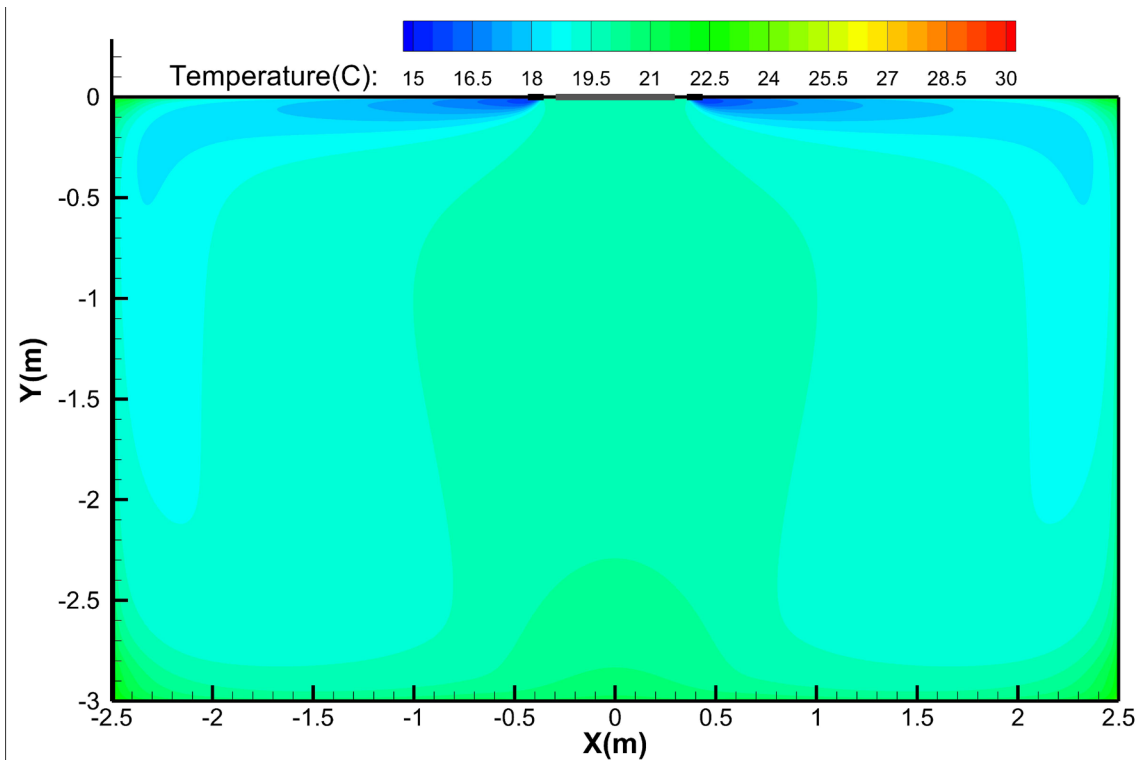

## Compact Cassette type -9k &12k

Heating airflow velocity distributions

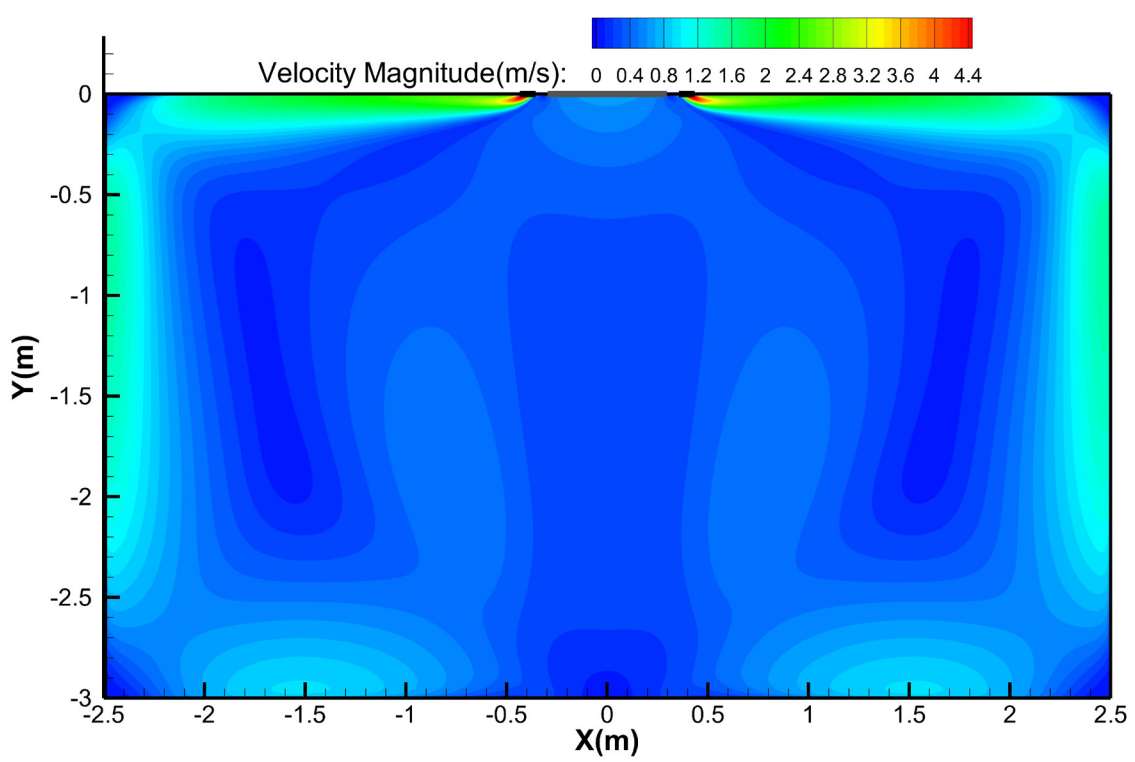

Heating temperature distributions

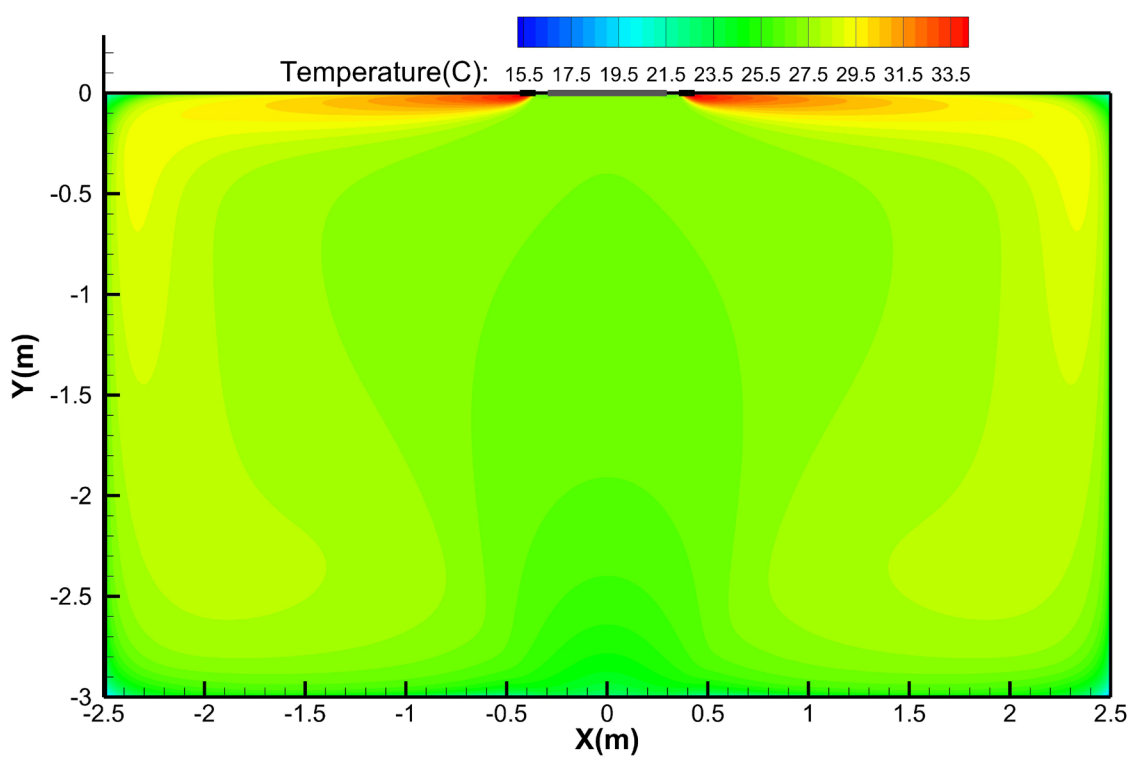

**Compact Cassette type -9k &12k**

Discharge Angle 60°

Cooling airflow velocity distributions

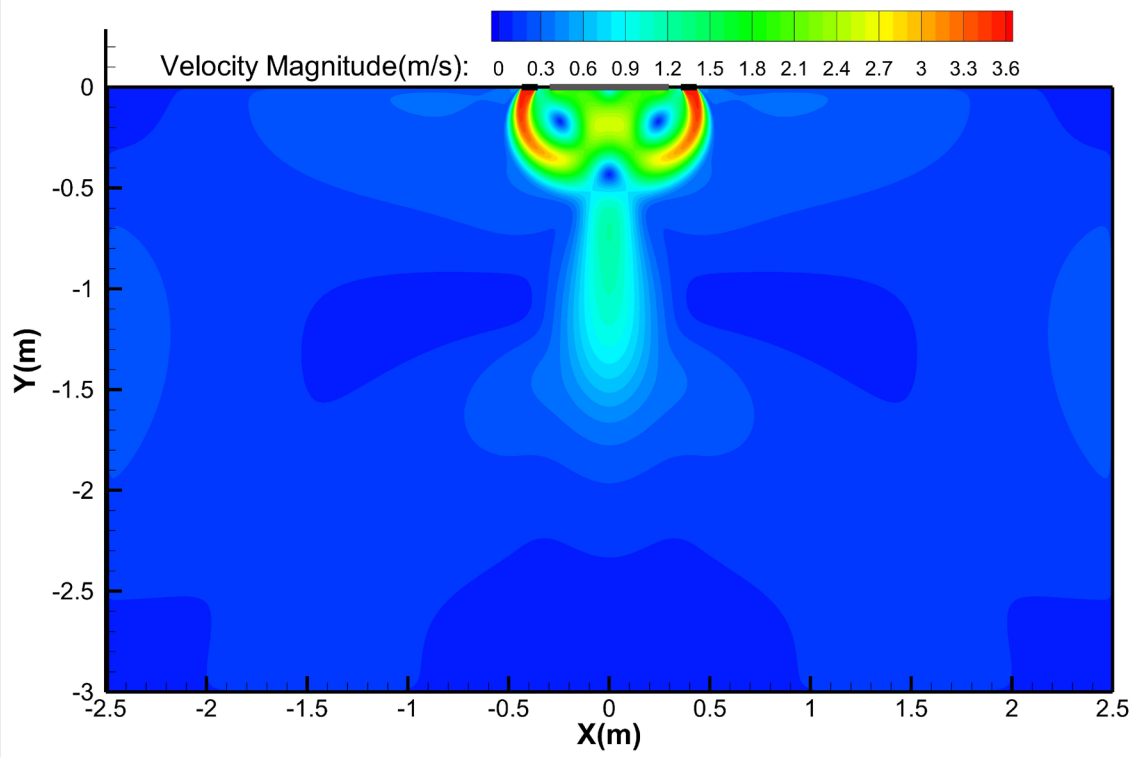

Cooling temperature distributions

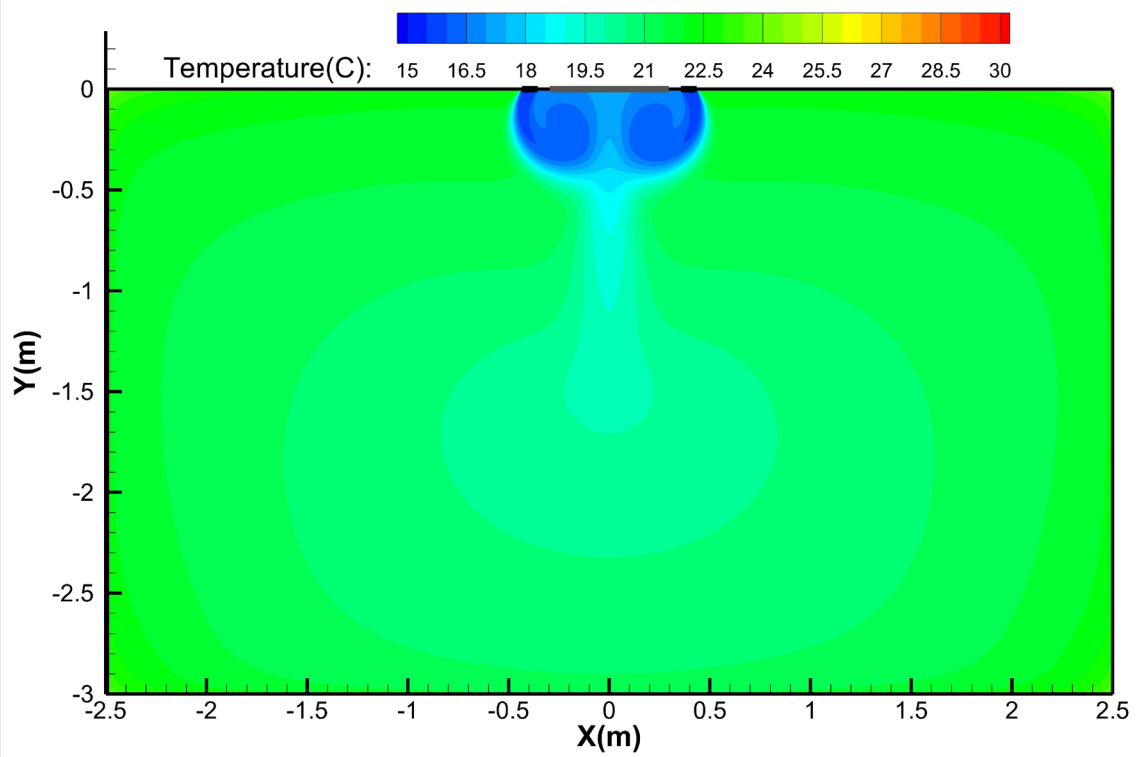

## Compact Cassette type -9k &12k

Heating airflow velocity distributions

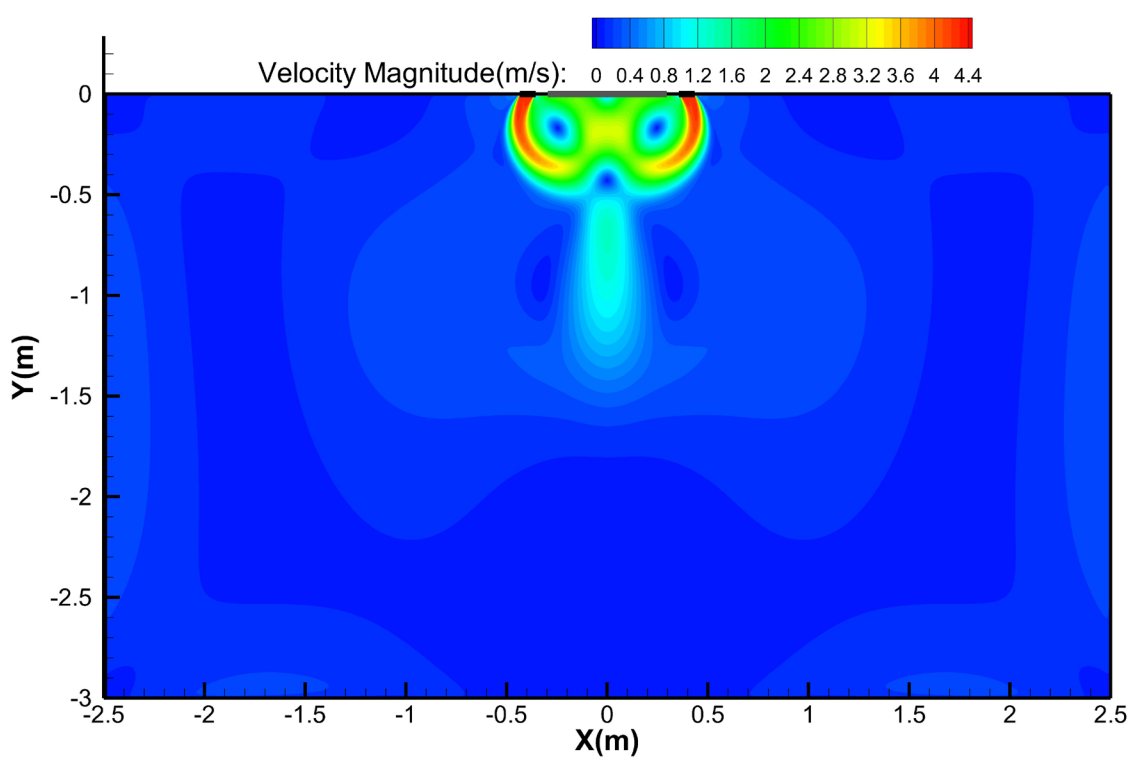

Heating temperature distributions

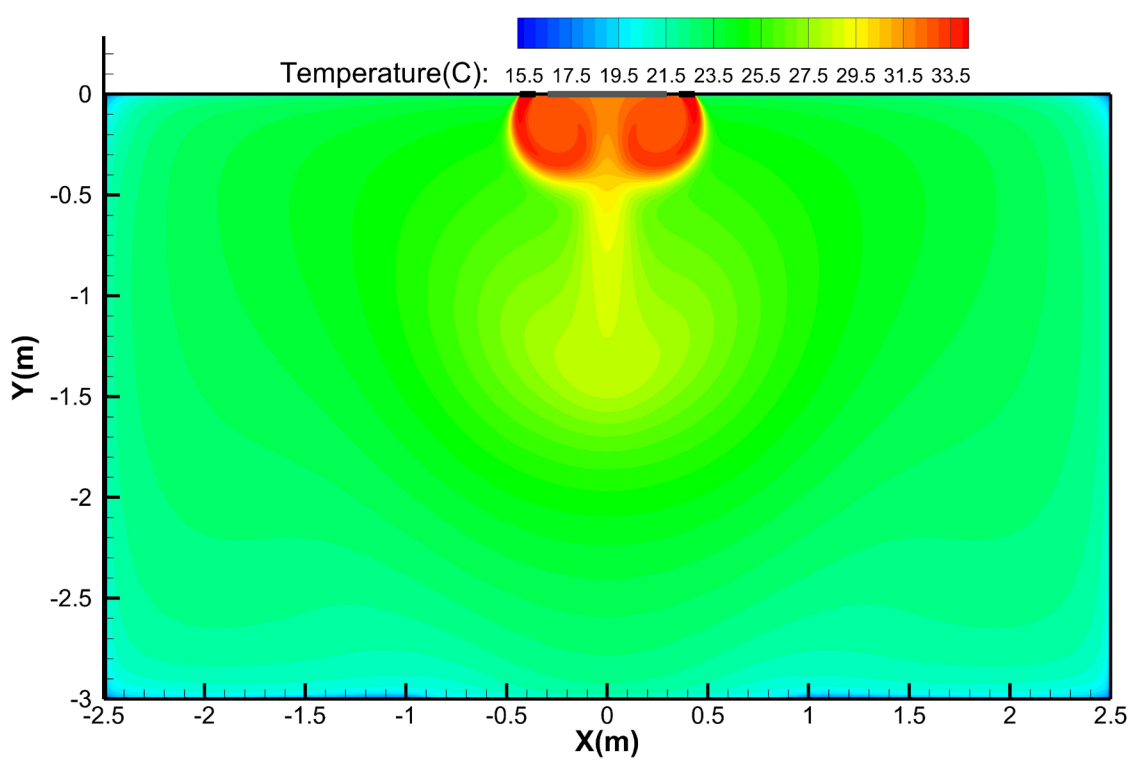

### Compact Cassette type -18k

Discharge Angle 30°

Cooling airflow velocity distributions

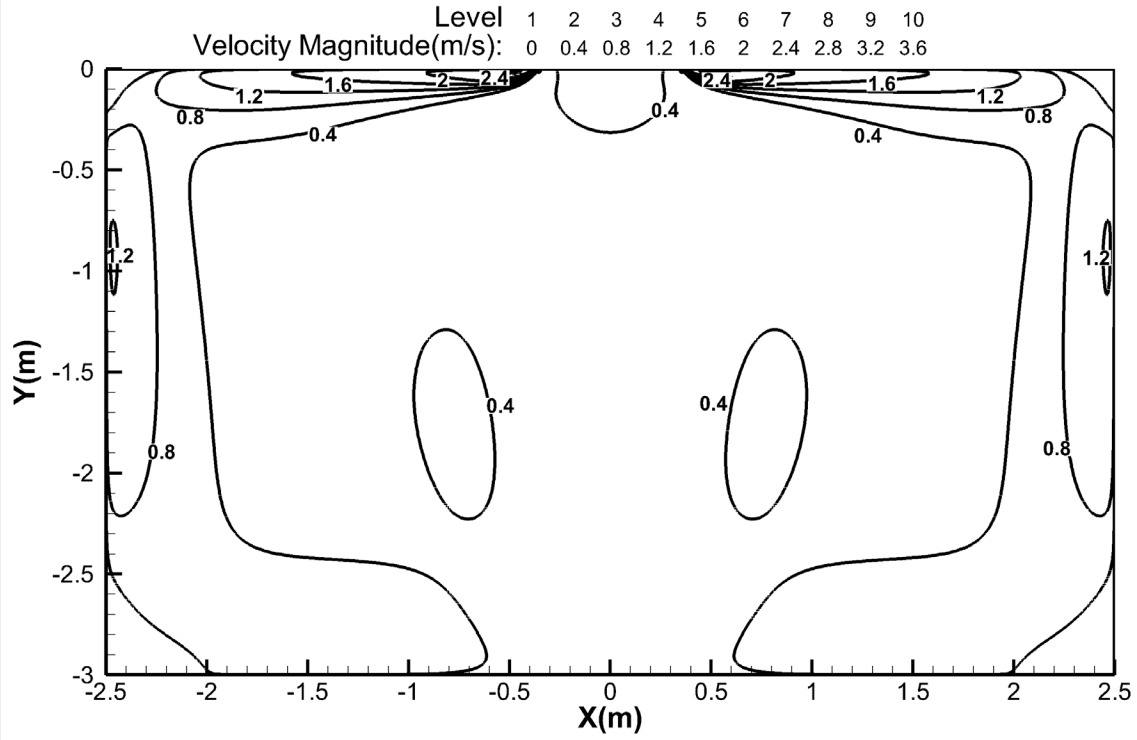

Cooling temperature distributions

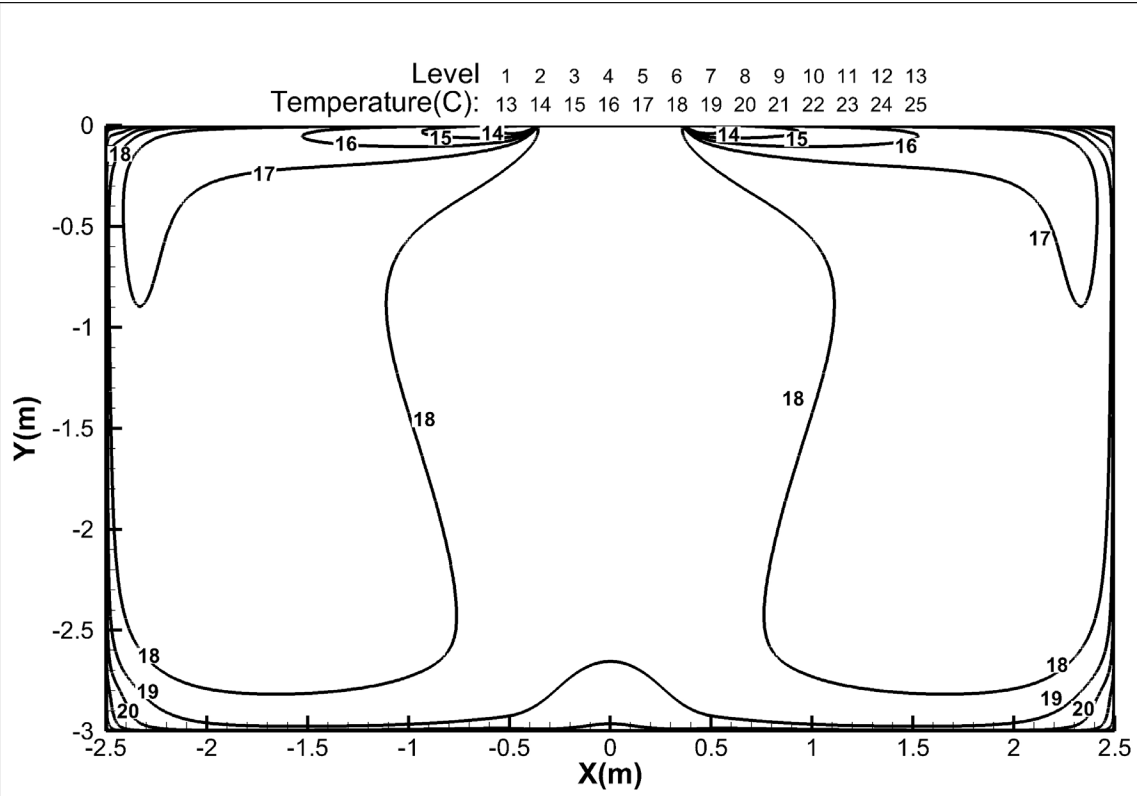

## Compact Cassette type -18k

Heating airflow velocity distributions

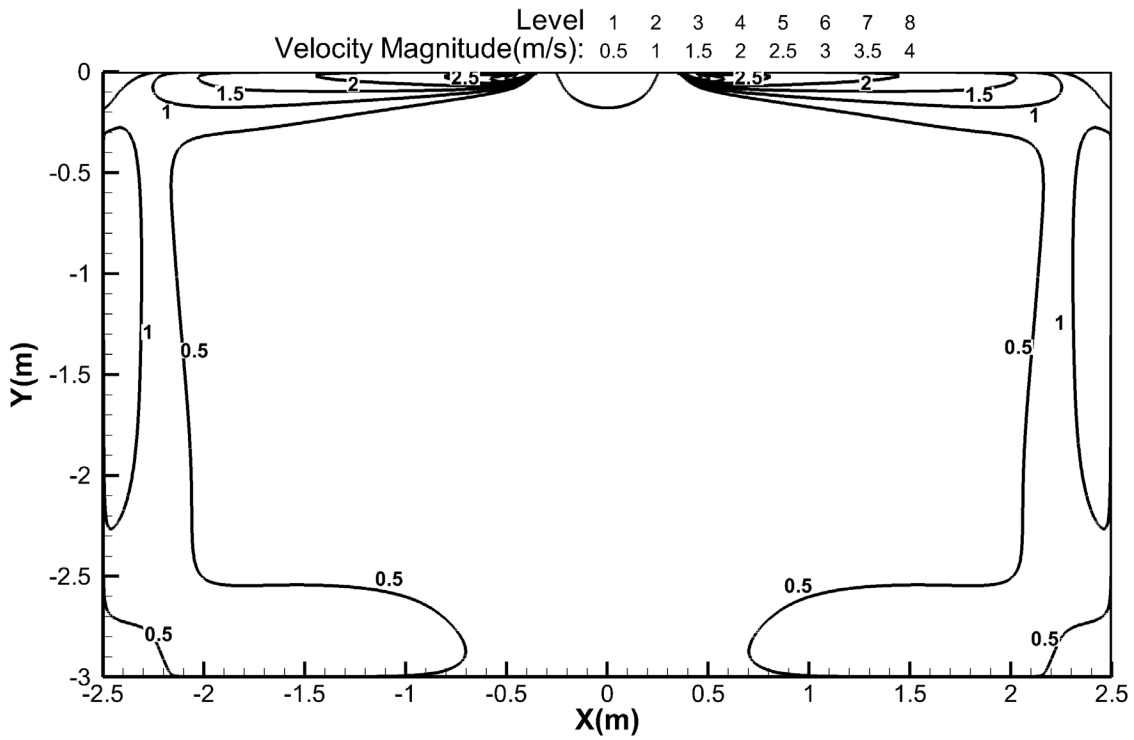

Heating temperature distributions

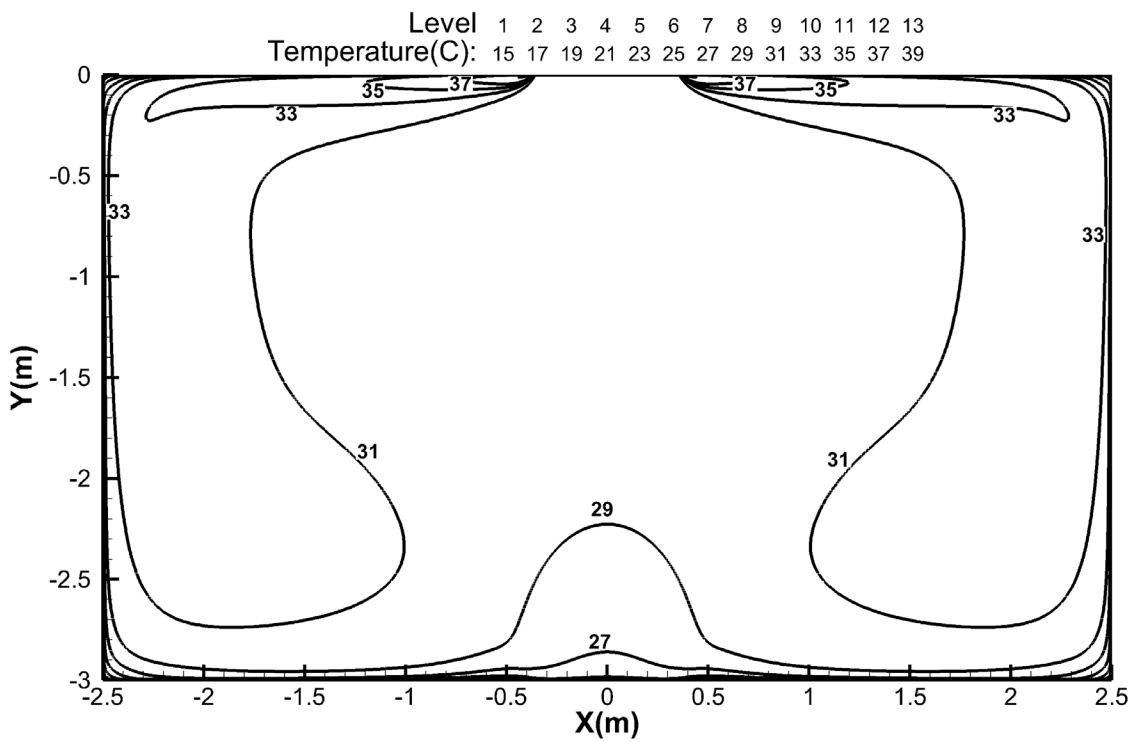

### Compact Cassette type -18k

Discharge Angle 60°

Cooling airflow velocity distributions

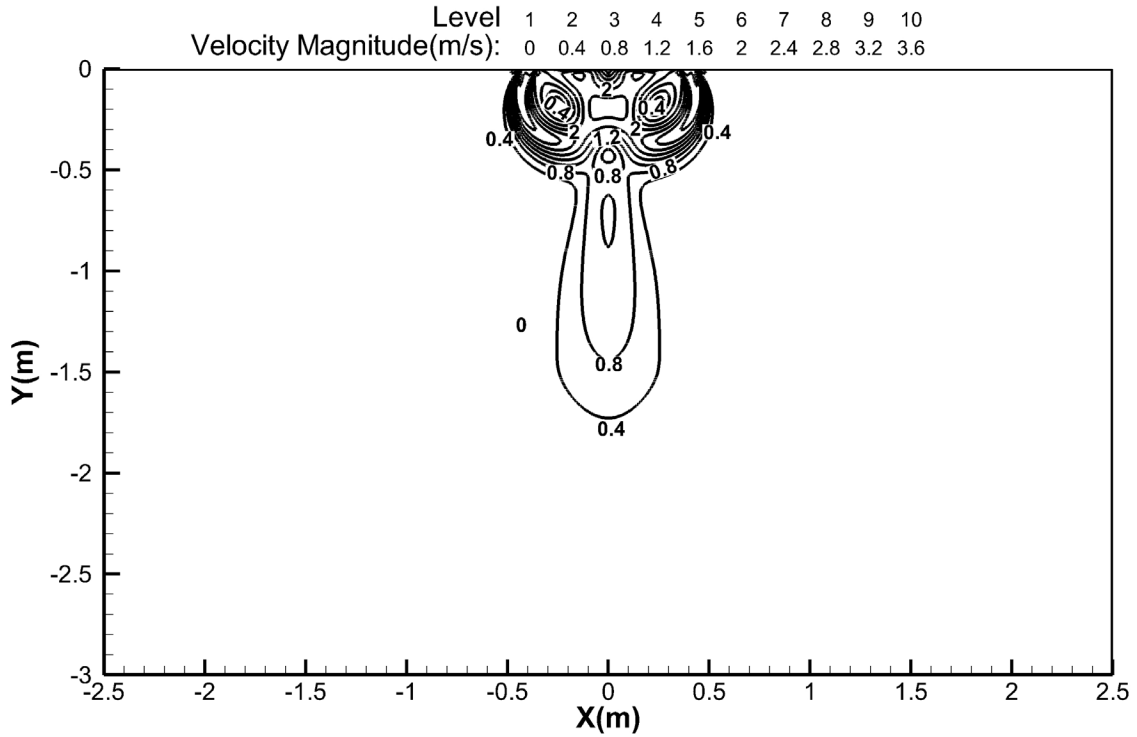

Cooling temperature distributions

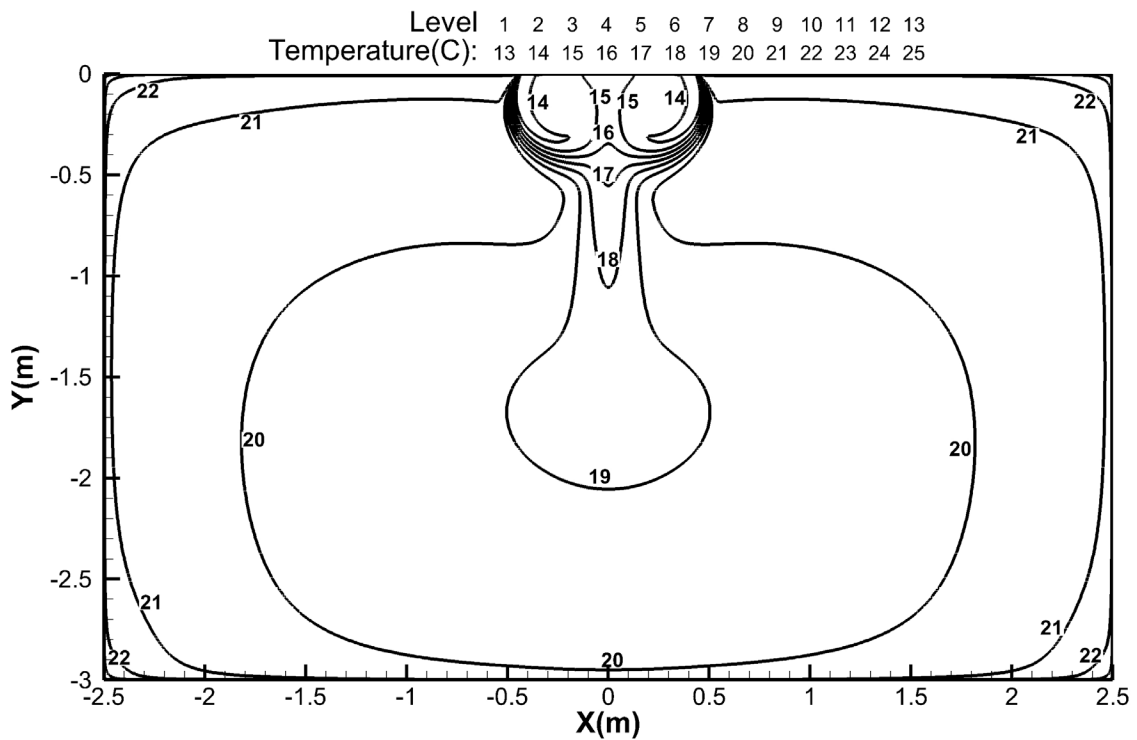

## Compact Cassette type -18k

Heating airflow velocity distributions

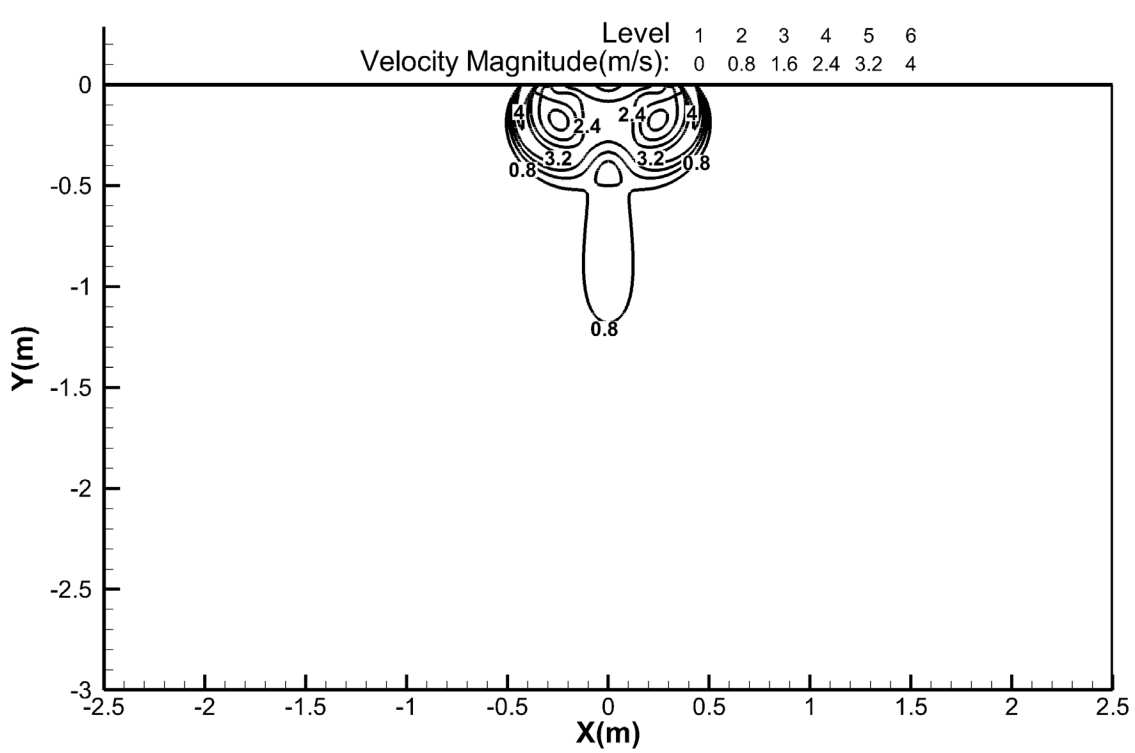

Heating temperature distributions

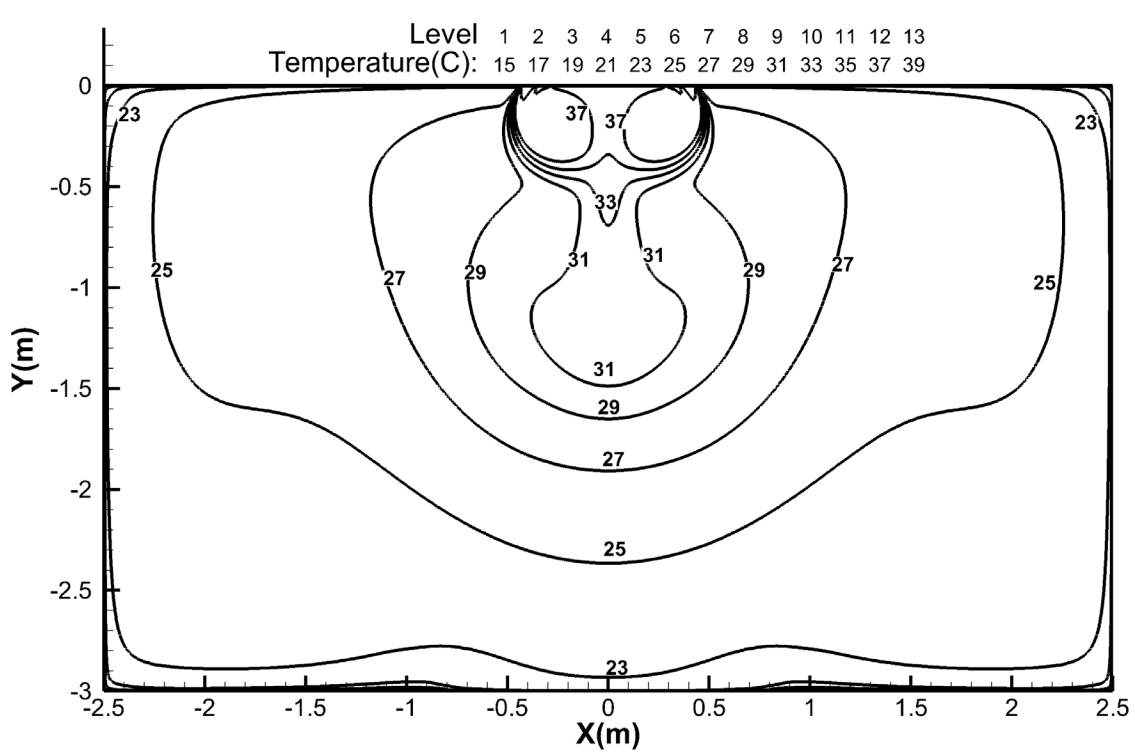



## Super-slim Cassette type -24k

Discharge Angle 30°

Cooling airflow velocity distributions

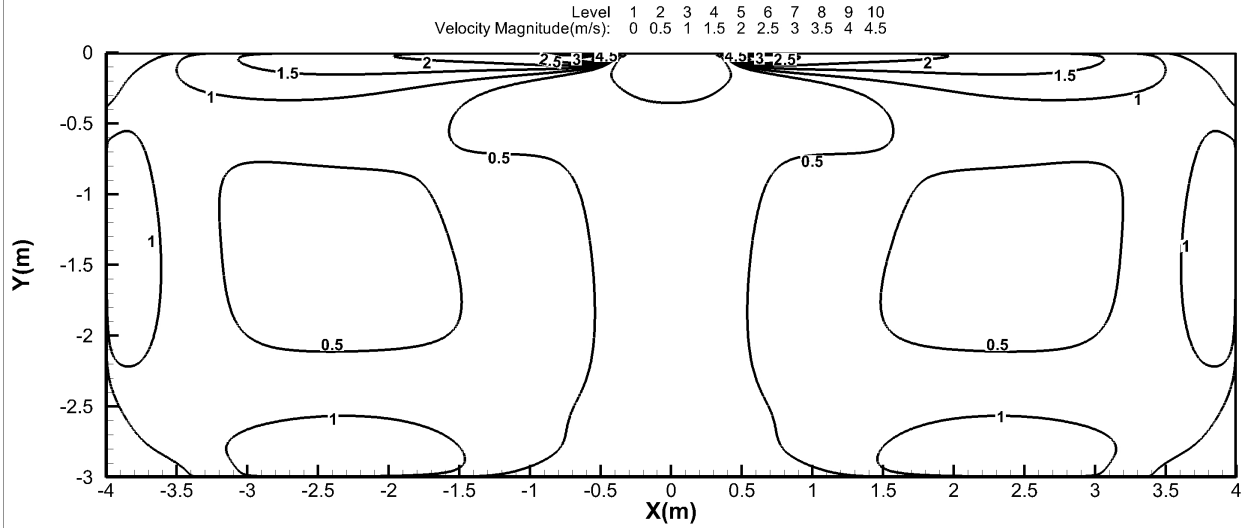

Cooling temperature distributions

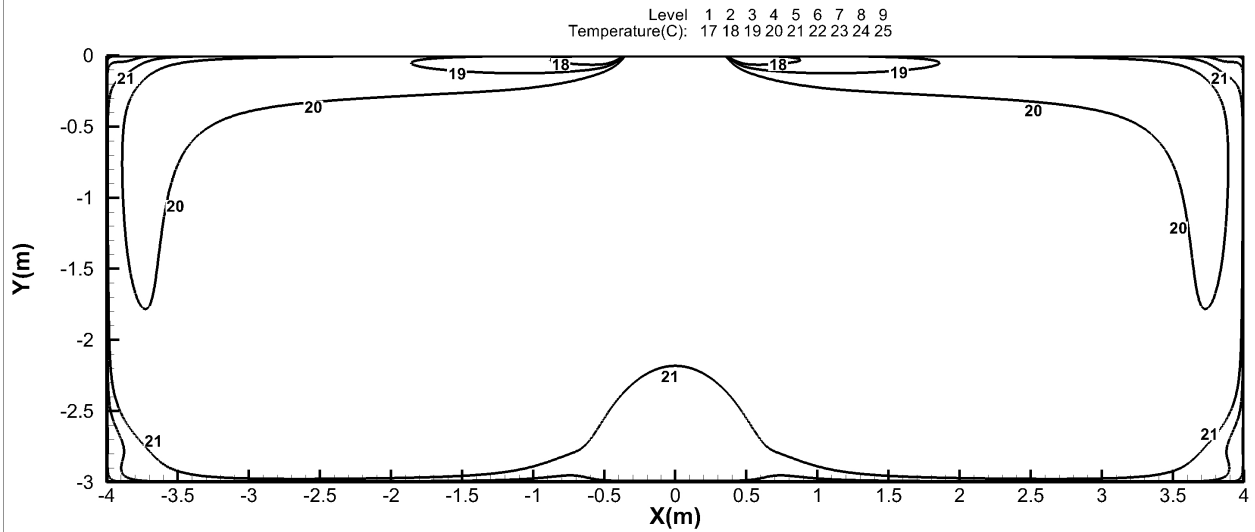

## Super-slim Cassette type -24k

Heating airflow velocity distributions

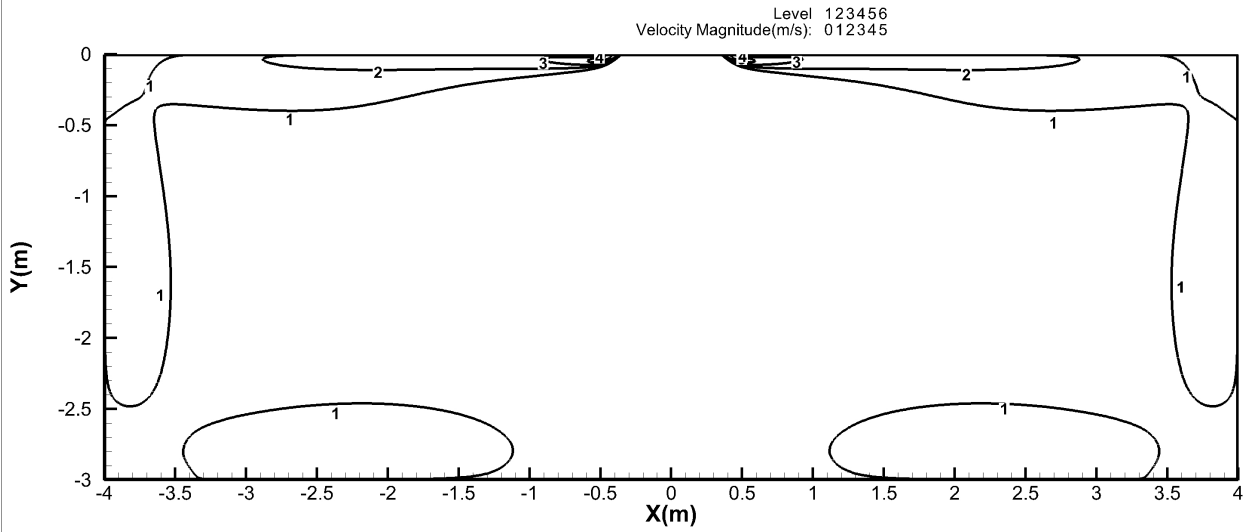

Heating temperature distributions

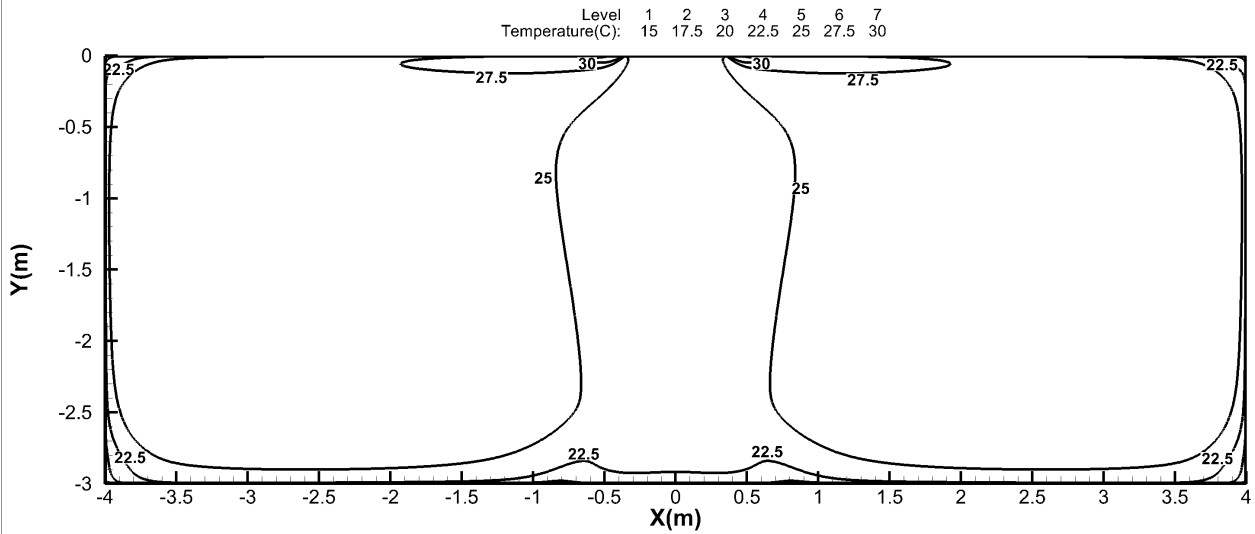

## Super-slim Cassette type -24k

Discharge Angle 60°

Cooling airflow velocity distributions

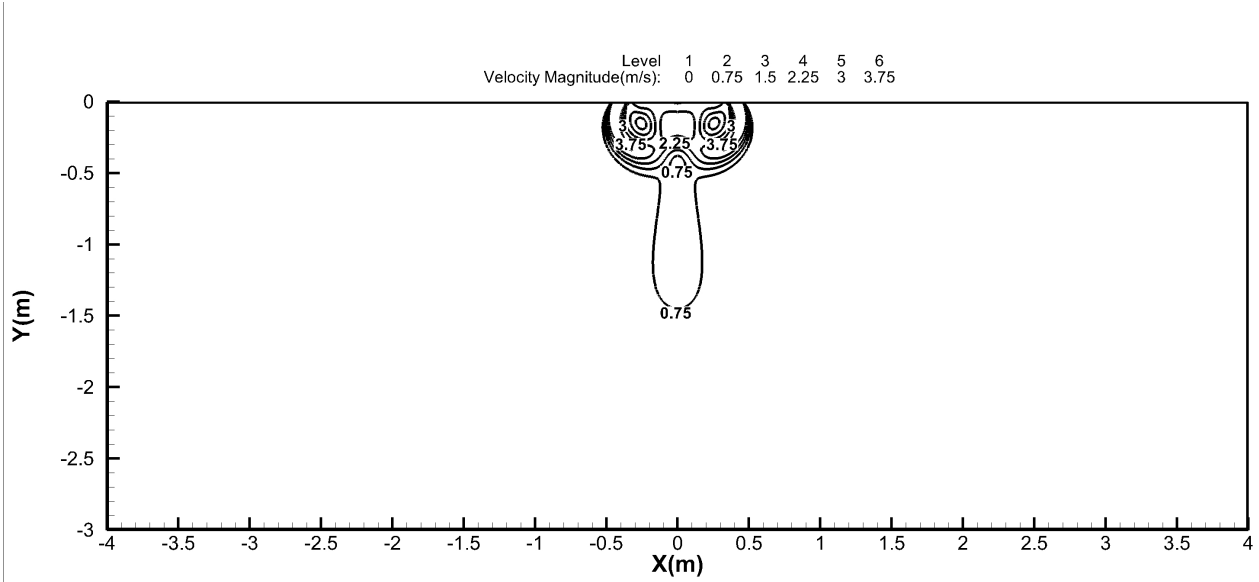

Cooling temperature distributions

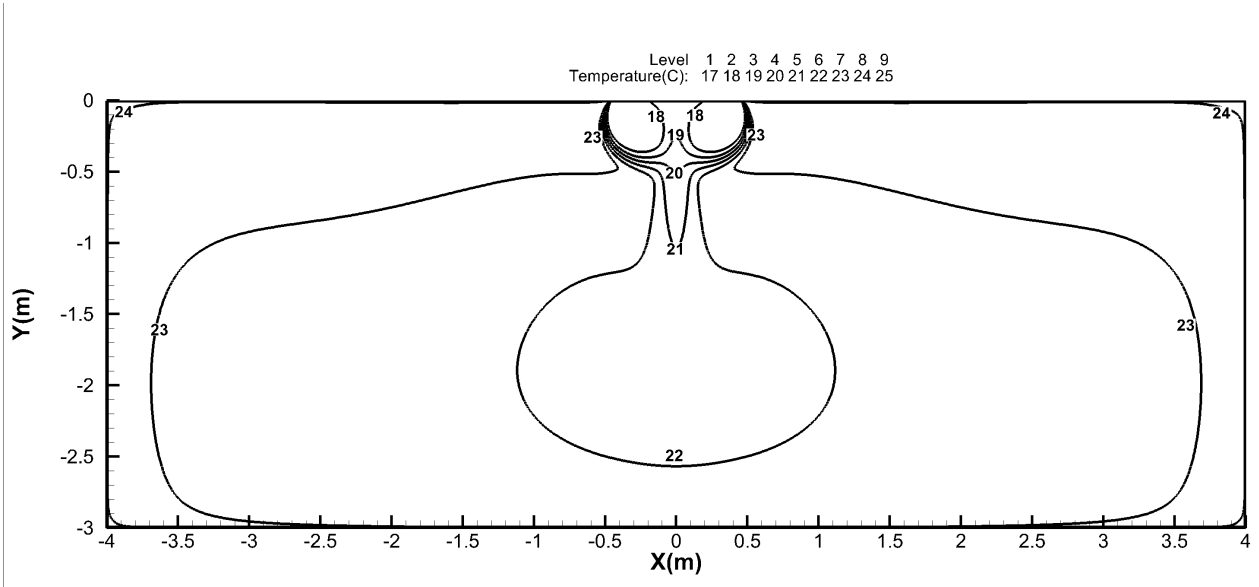

## Super-slim Cassette type -24k

Heating airflow velocity distributions

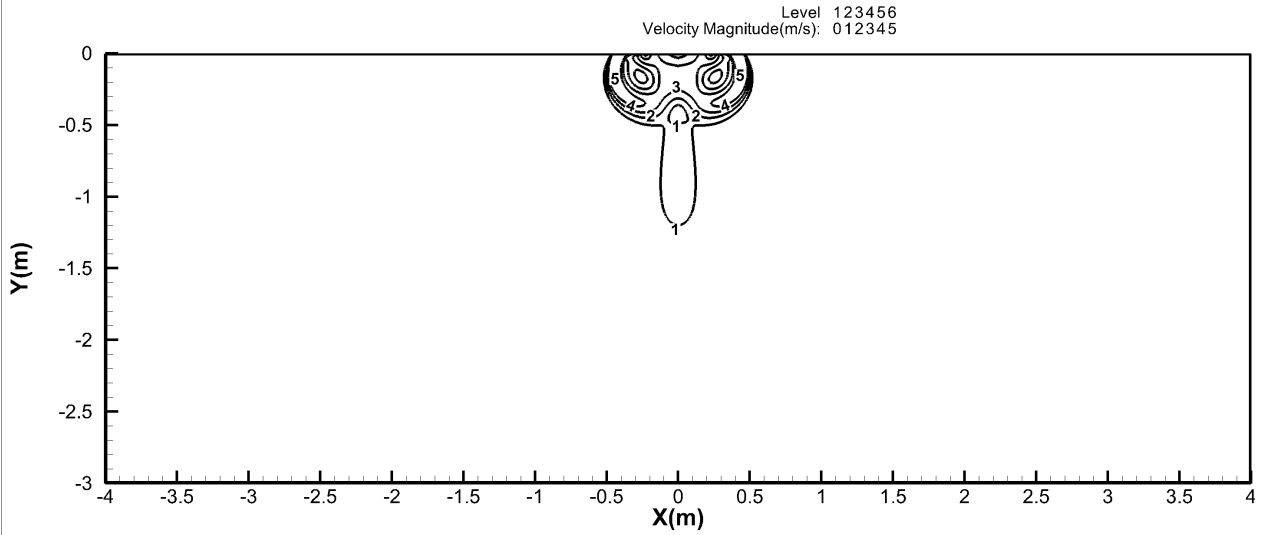

Heating temperature distributions

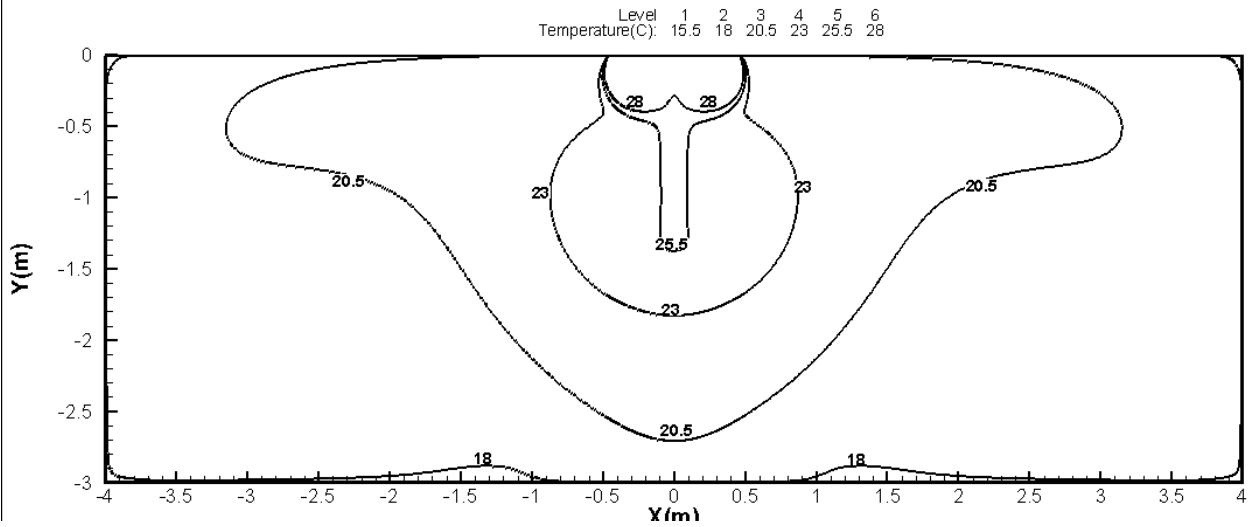

### Floor Ceiling Type -18k

Ceiling installation:

Discharge Angle 30°

Cooling airflow velocity distributions

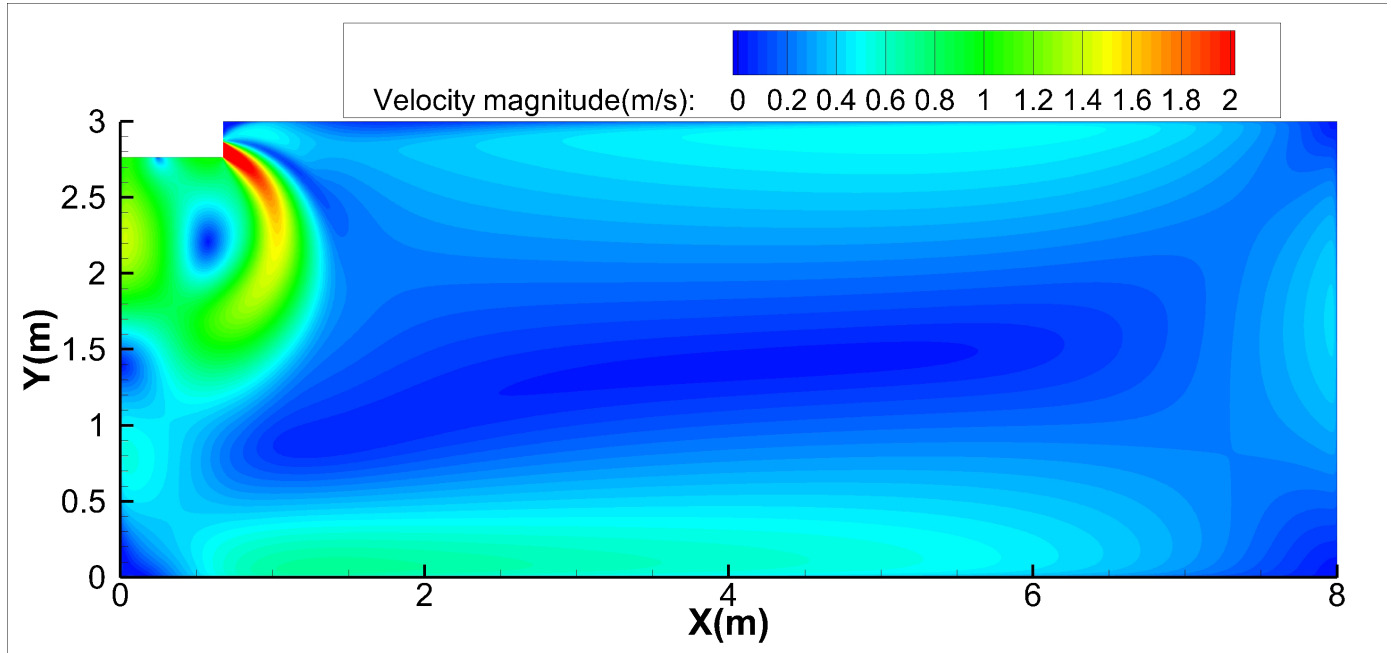

Specifications

Cooling temperature distributions

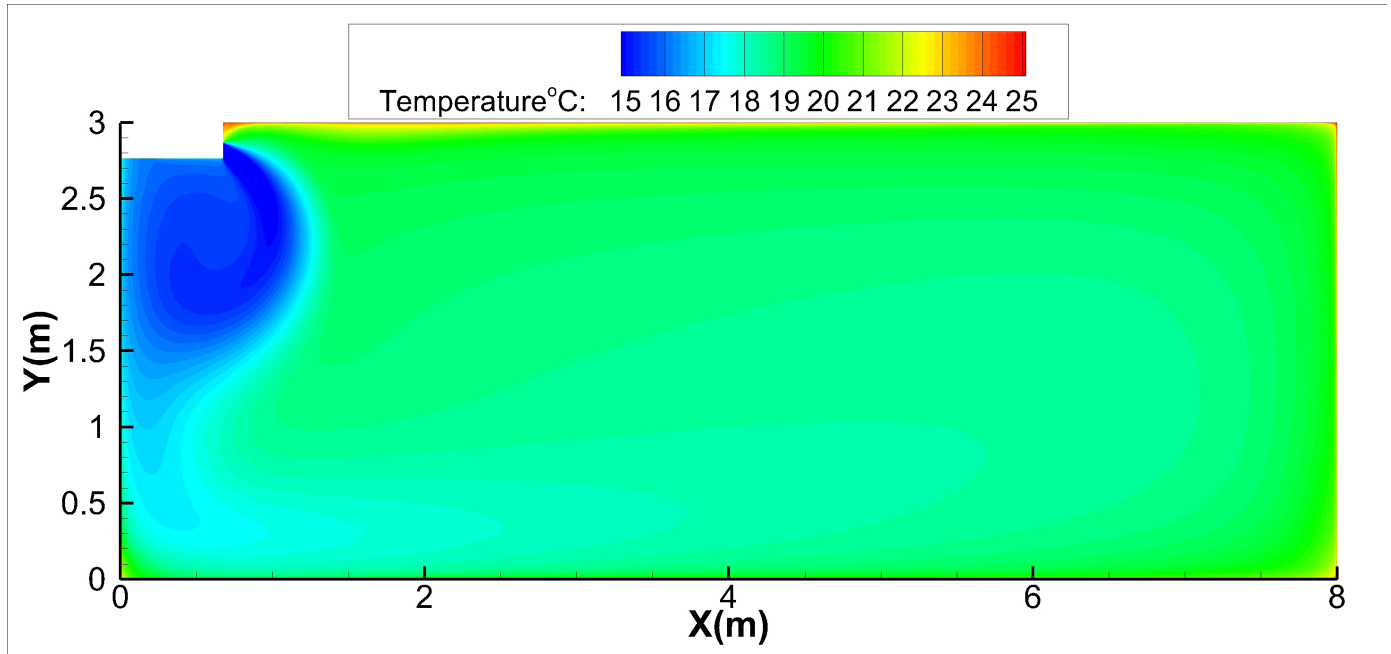

### Floor Ceiling Type -18k

Ceiling installation:

Discharge Angle 60°

Cooling airflow velocity distributions

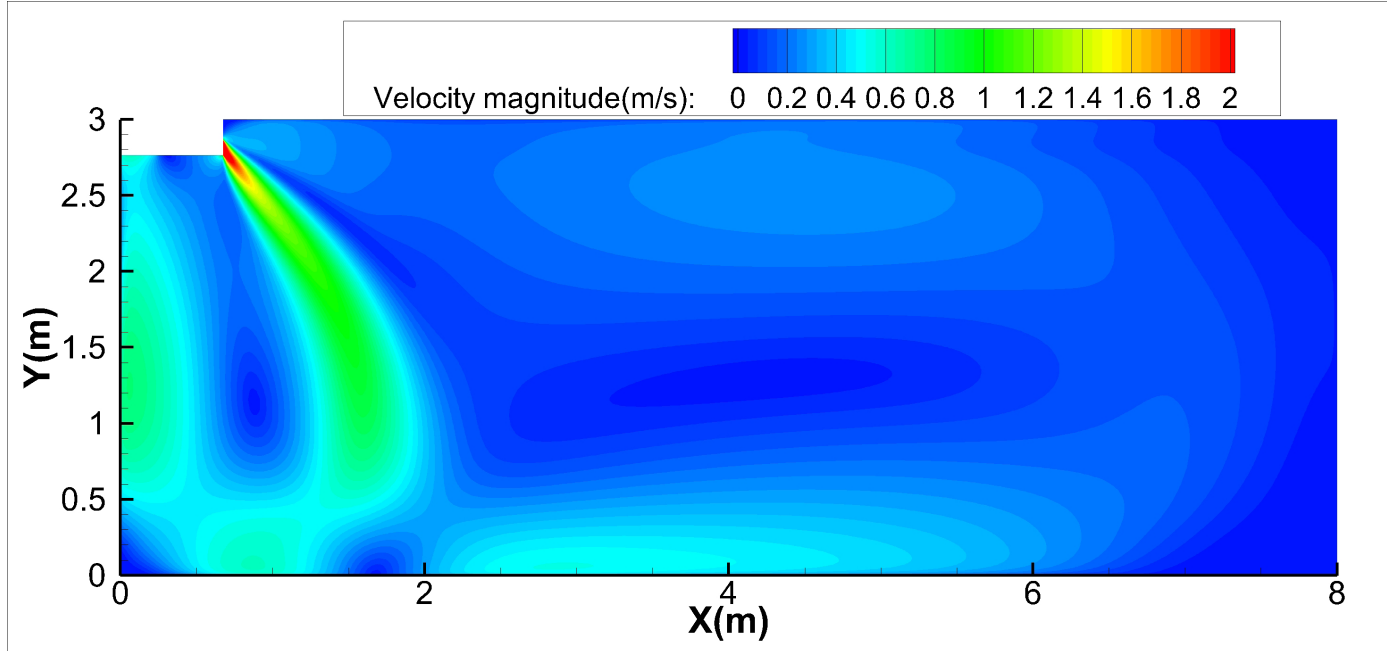

Cooling temperature distributions

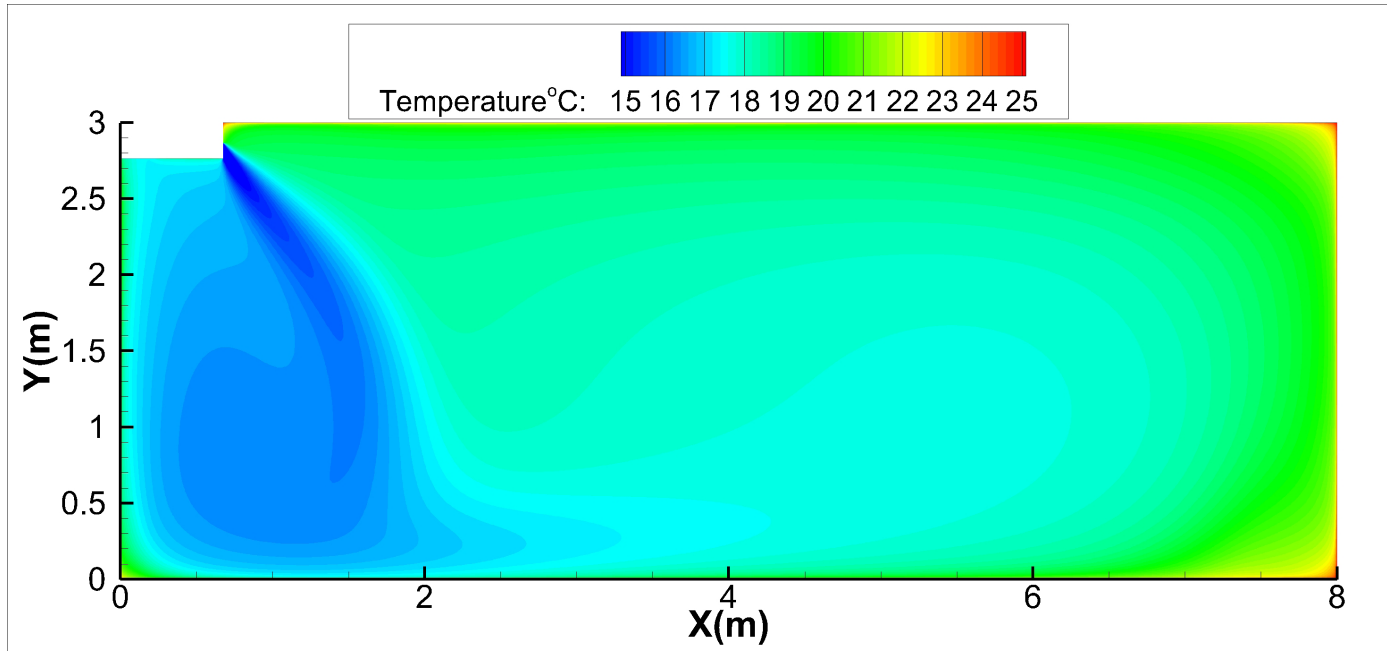

## Floor Ceiling Type -18k

Ceiling installation:

Discharge Angle 30°

Heating airflow velocity distributions

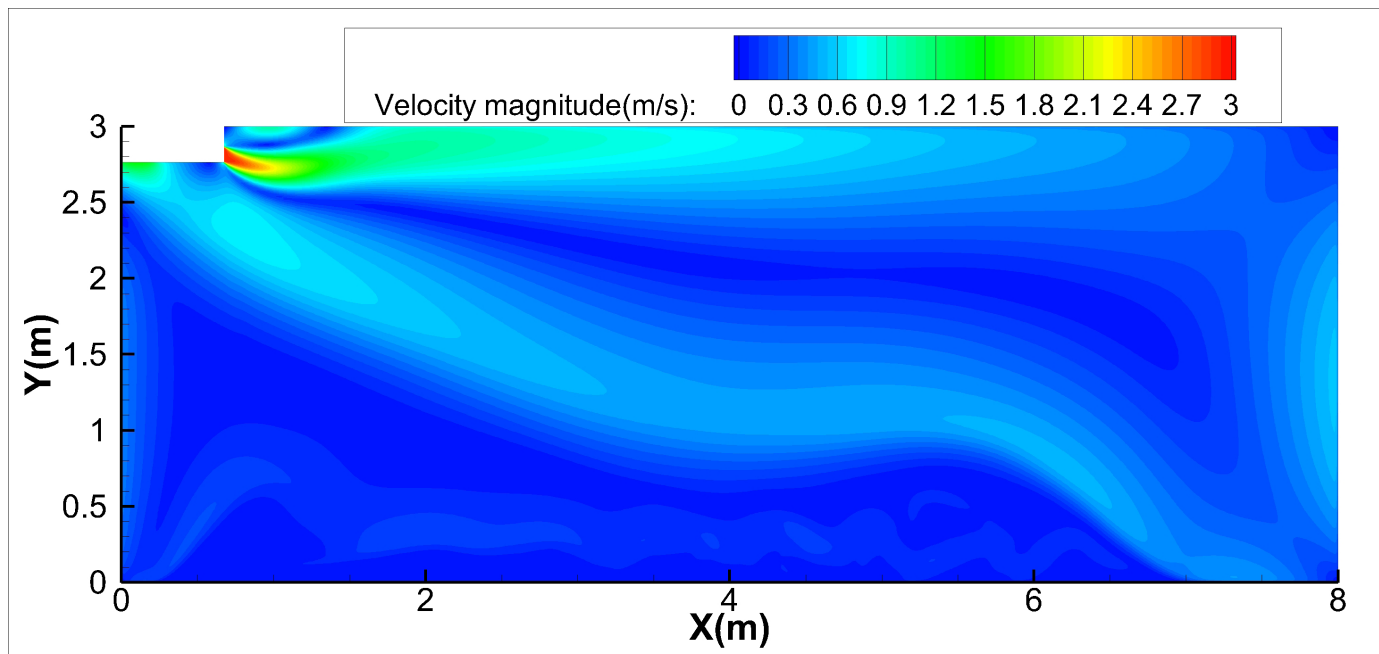

Specifications

Heating temperature distributions

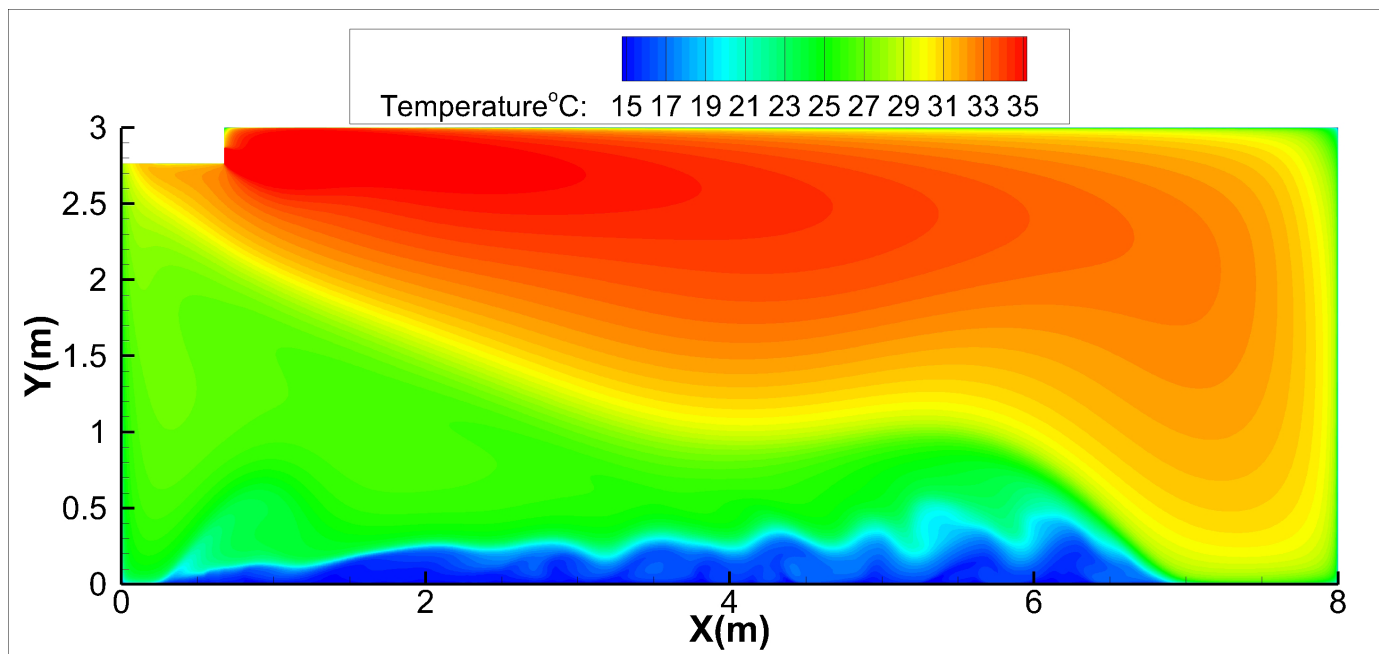

## Floor Ceiling Type -18k

Ceiling installation:

Discharge Angle 60°

Heating airflow velocity distributions

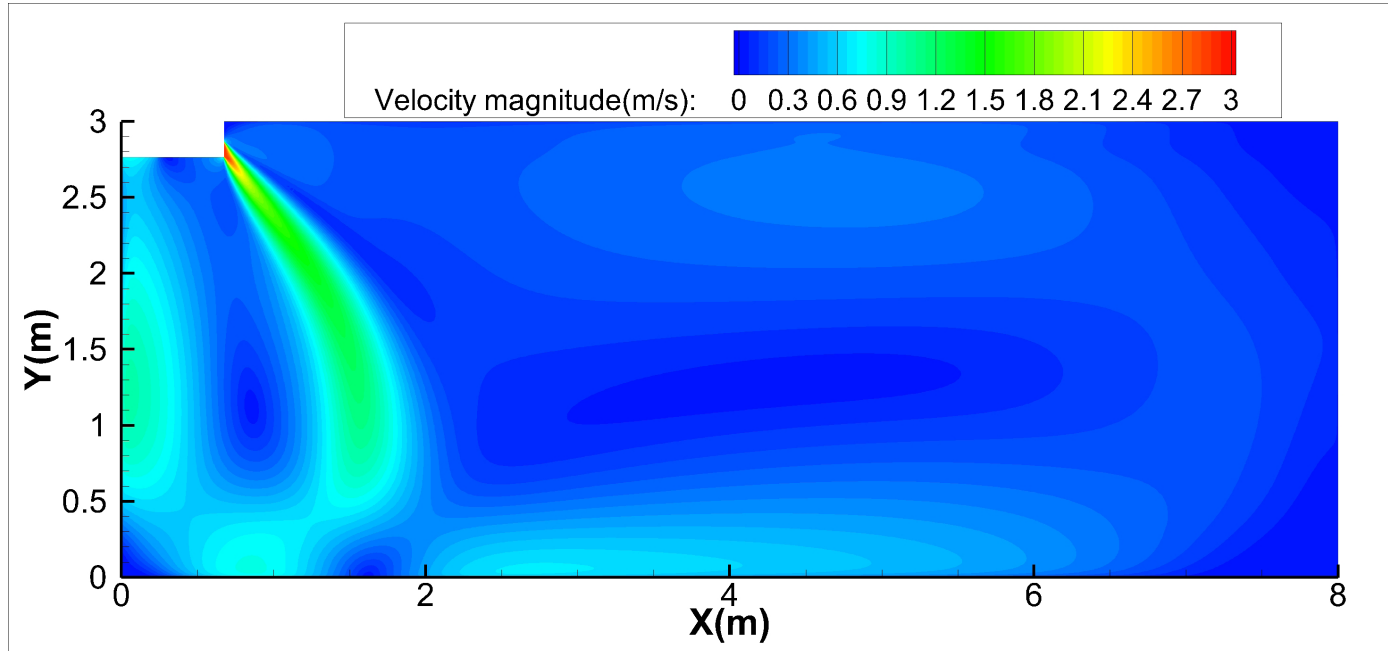

Heating temperature distributions

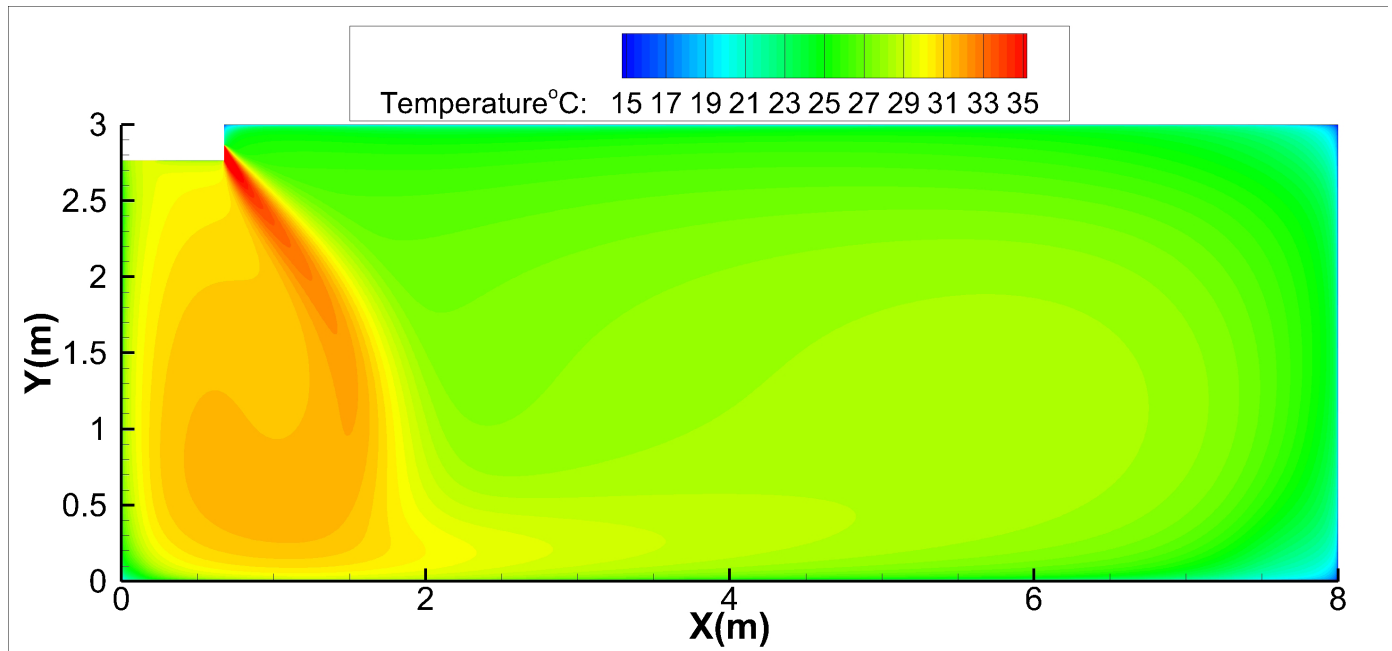



### Floor Ceiling Type -18k

Floor installation:

Discharge Angle 30°

Cooling airflow velocity distributions

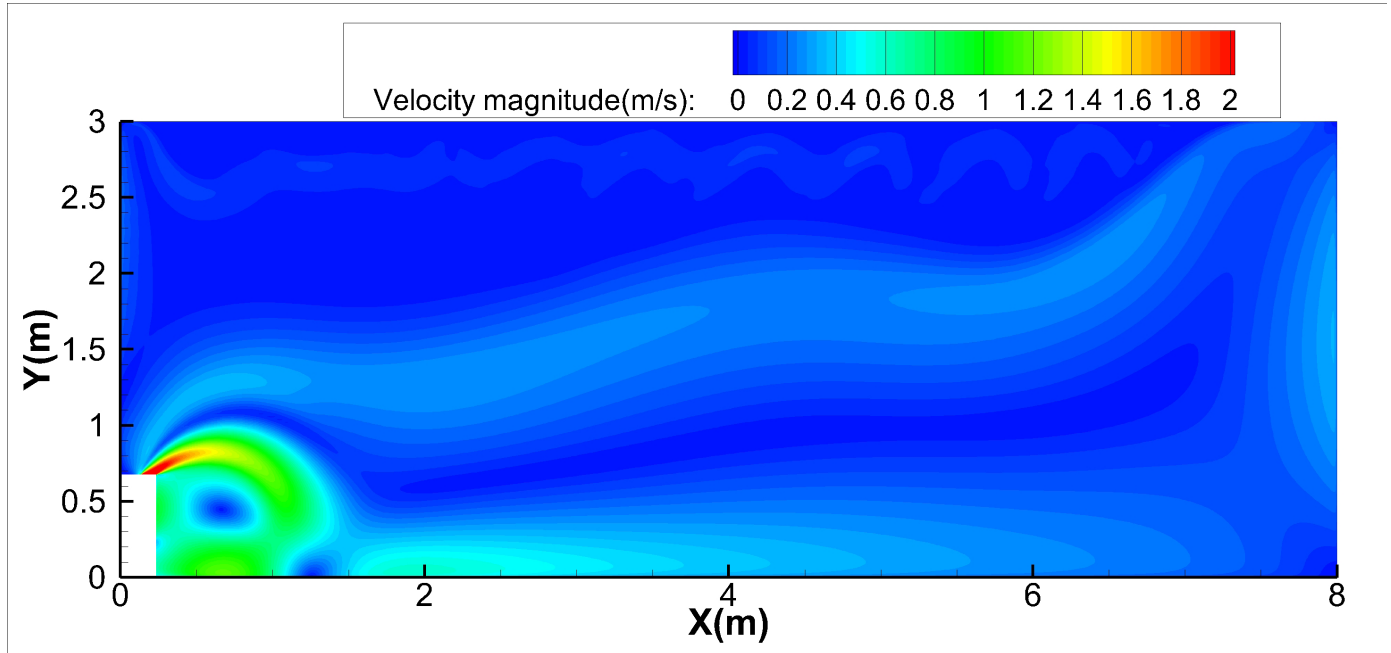

Specifications

Cooling temperature distributions

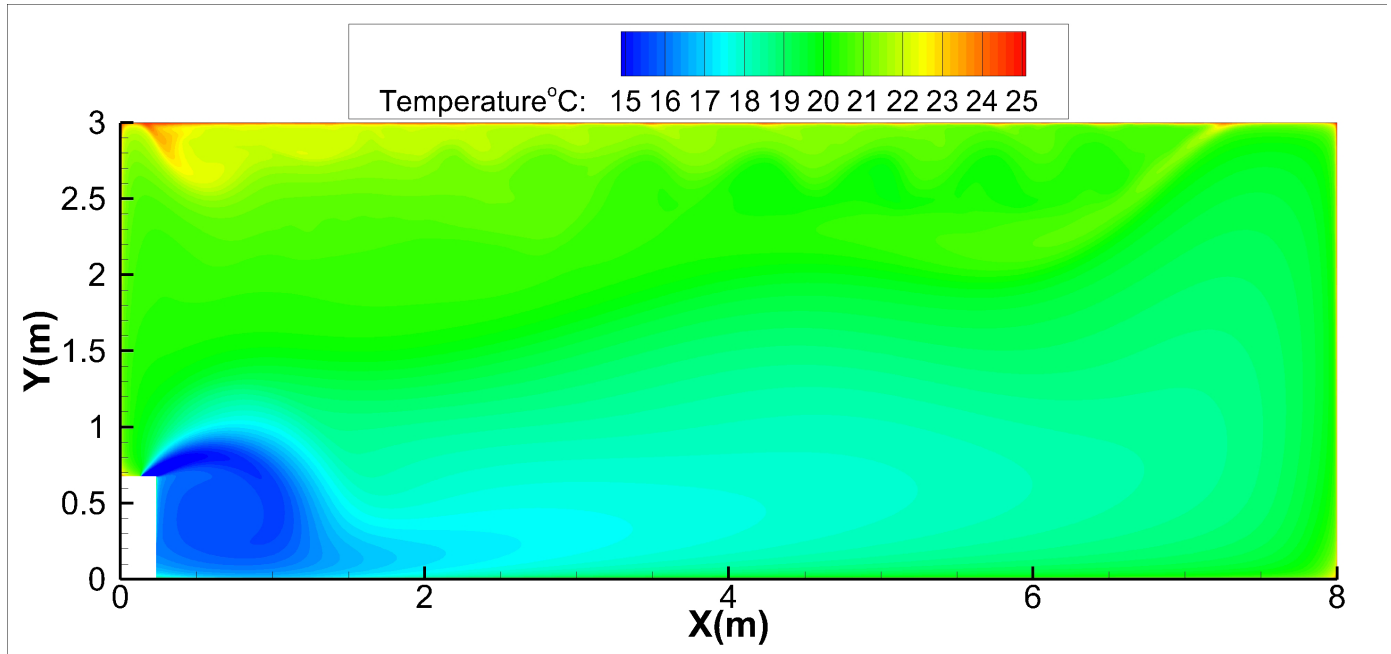

## Floor Ceiling Type -18k

Floor installation:

Discharge Angle 60°

Cooling airflow velocity distributions

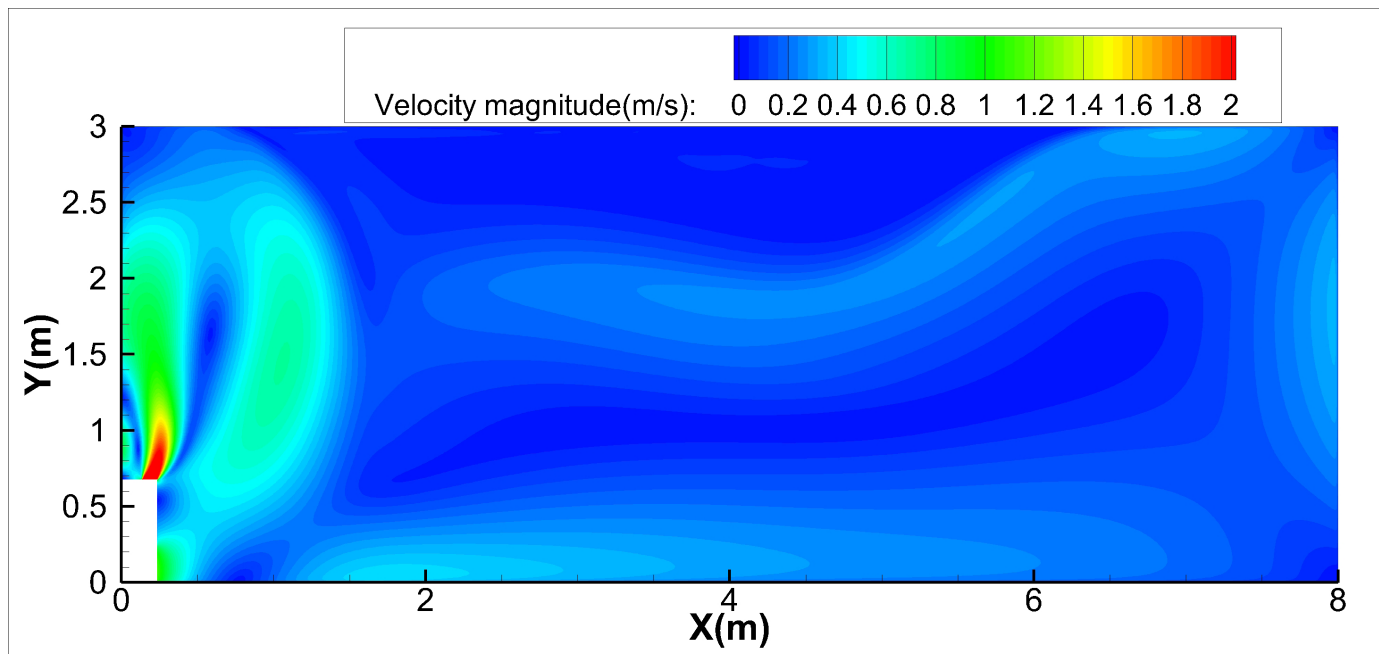

Specifications

Cooling temperature distributions

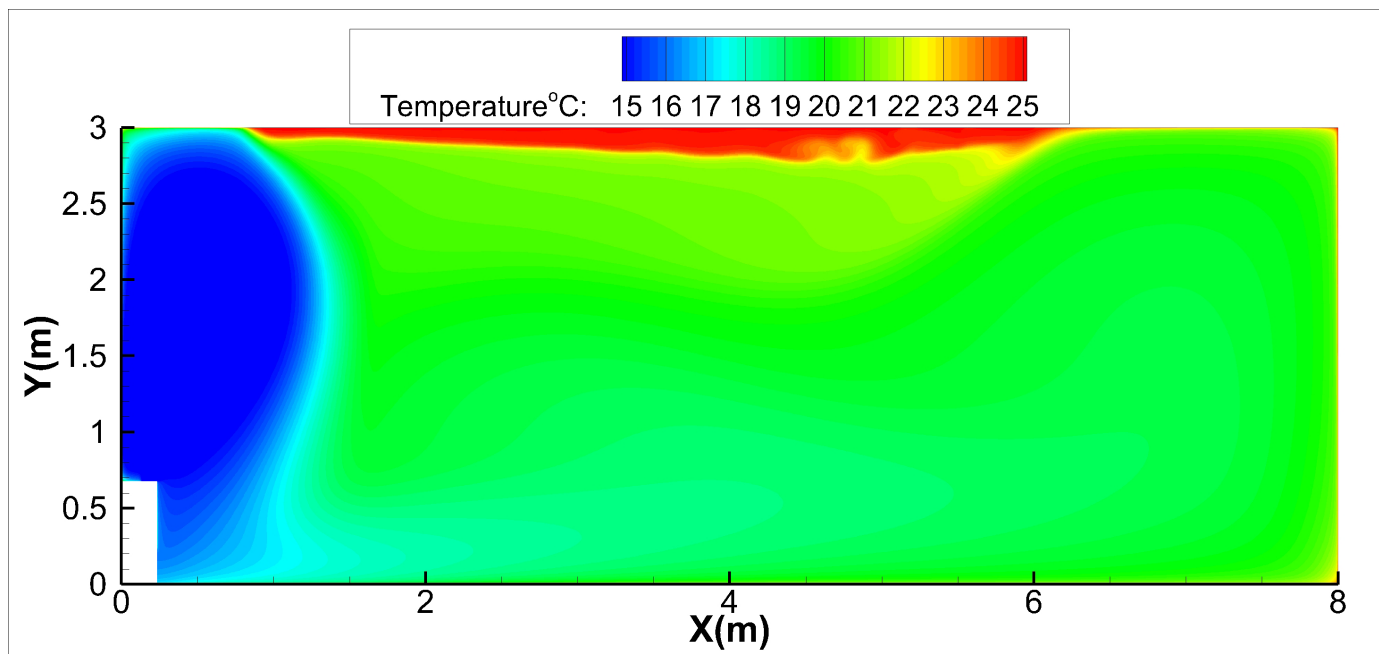

## Floor Ceiling Type -18k

Floor installation:

Discharge Angle 30°

Heating airflow velocity distributions

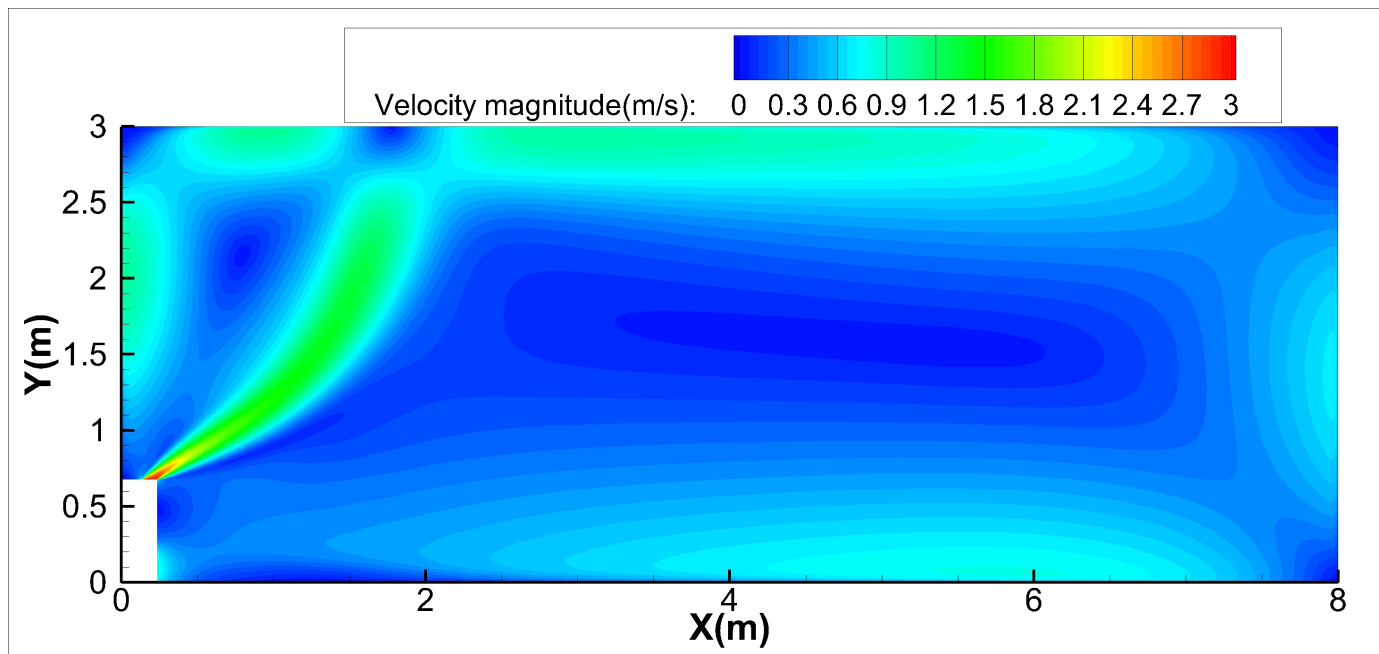

Specifications

Heating temperature distributions

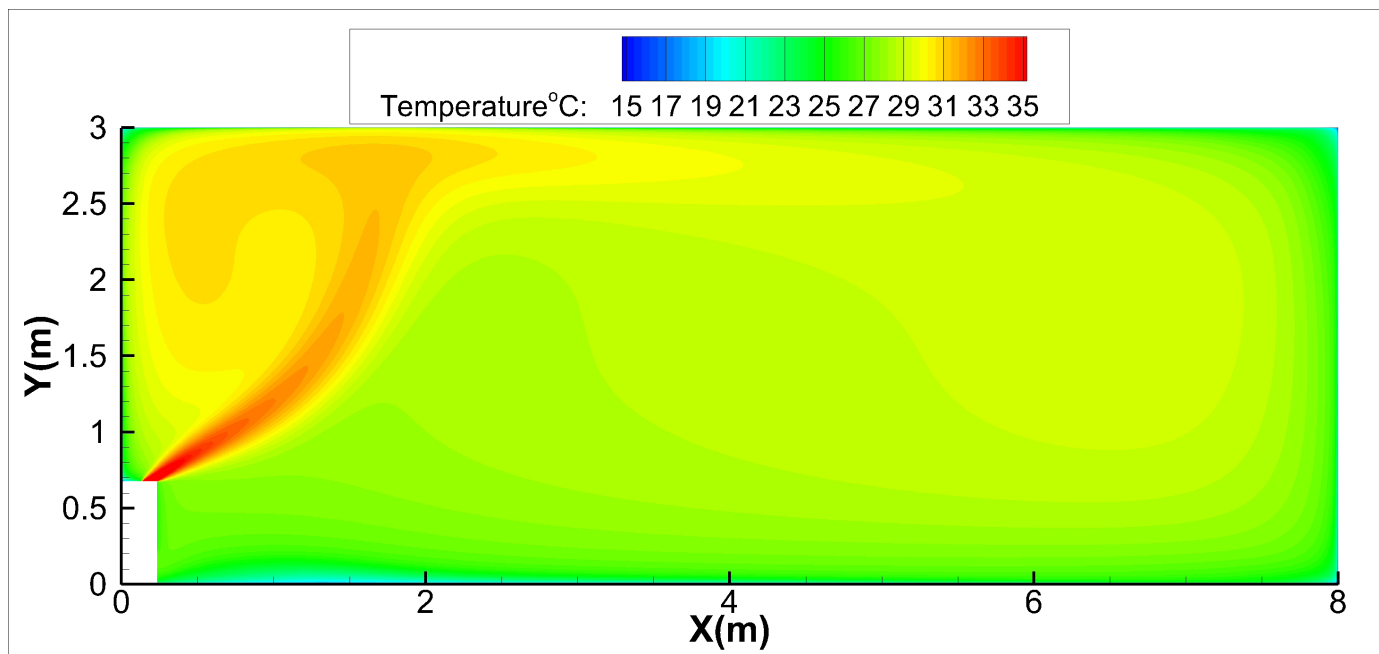

## Floor Ceiling Type -18k

Floor installation:

Discharge Angle 60°

Heating airflow velocity distributions

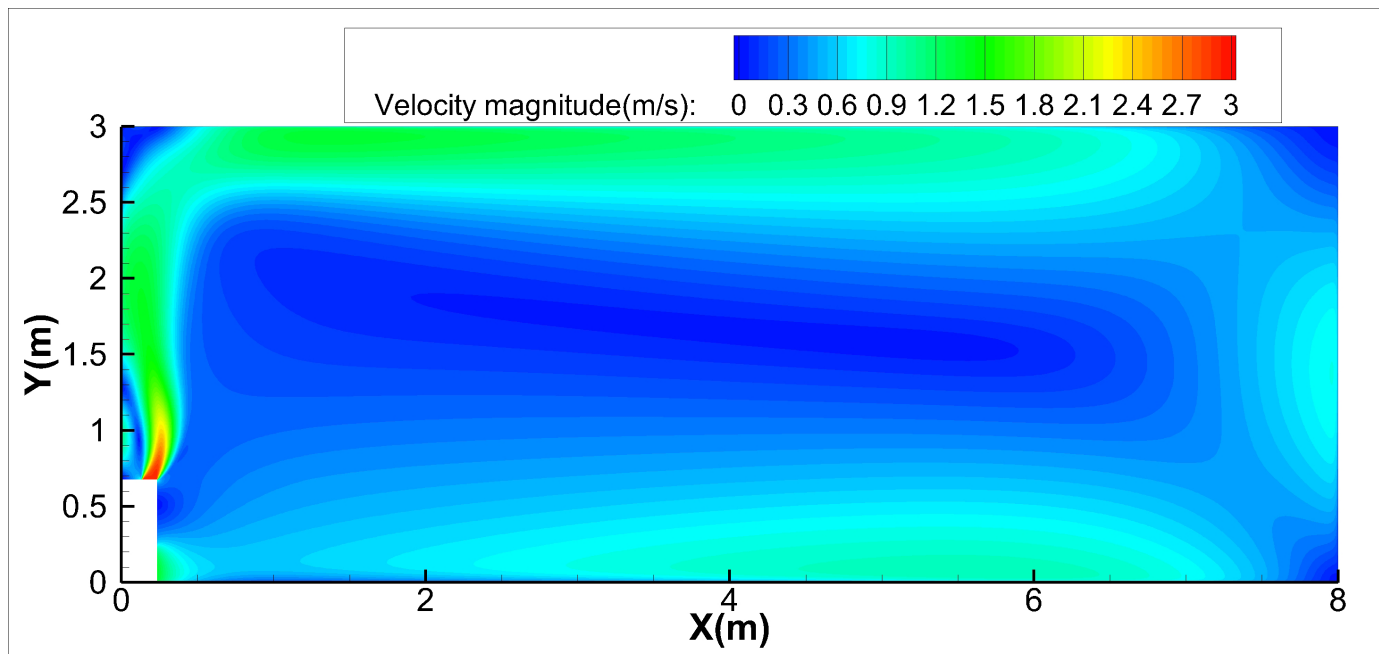

Heating temperature distributions

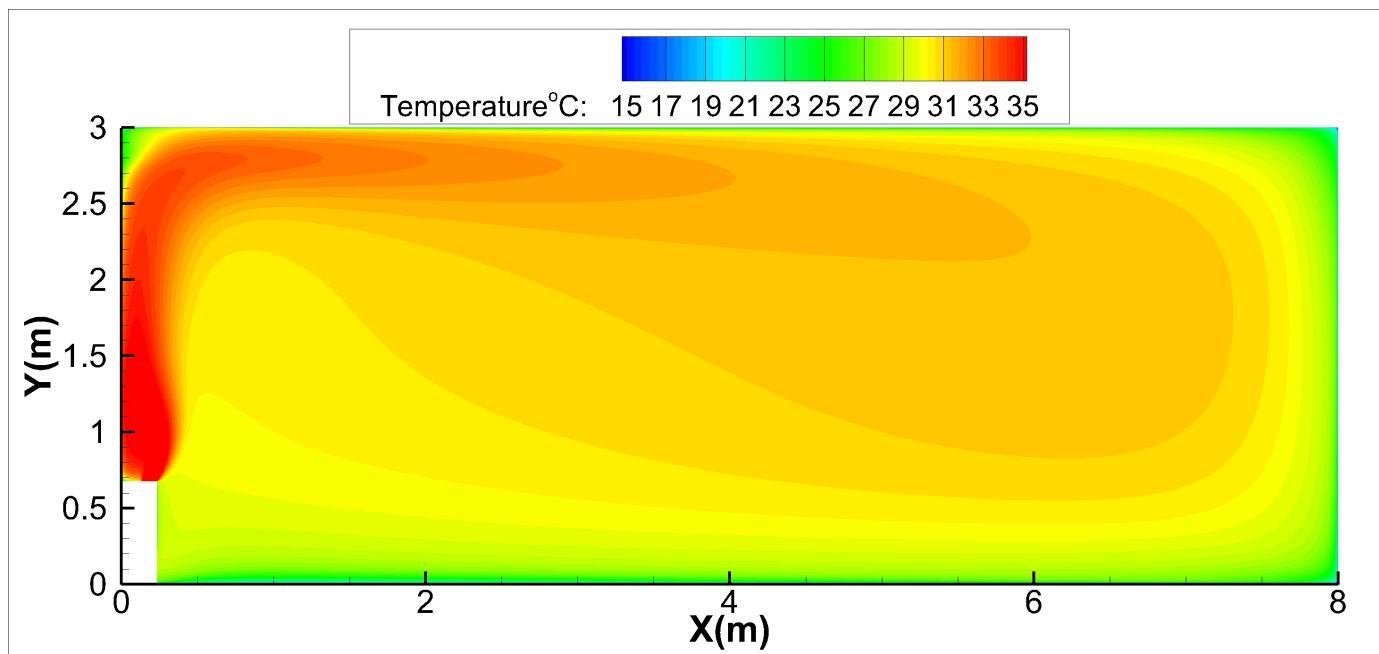

### Floor Ceiling Type -24k

Ceiling installation:

Discharge Angle 30°

Cooling airflow velocity distributions

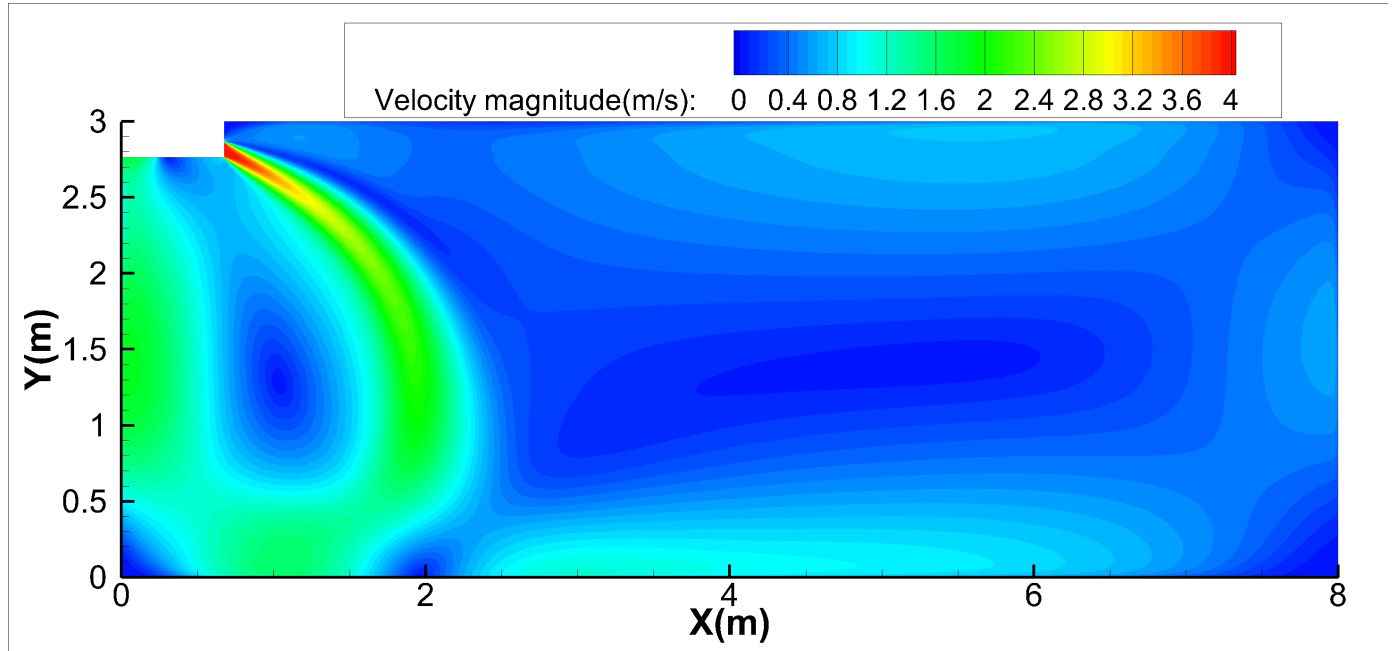

Specifications

Cooling temperature distributions

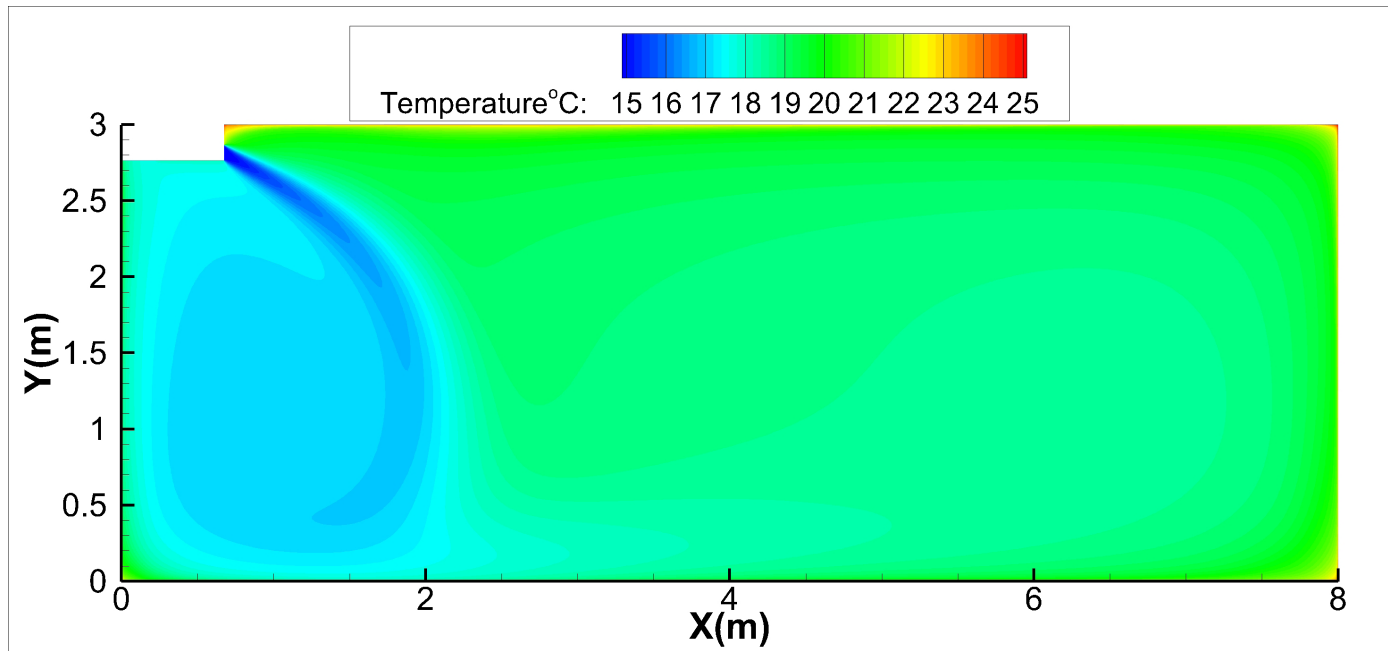

### Floor Ceiling Type -24k

Ceiling installation:

Discharge Angle 60°

Cooling airflow velocity distributions

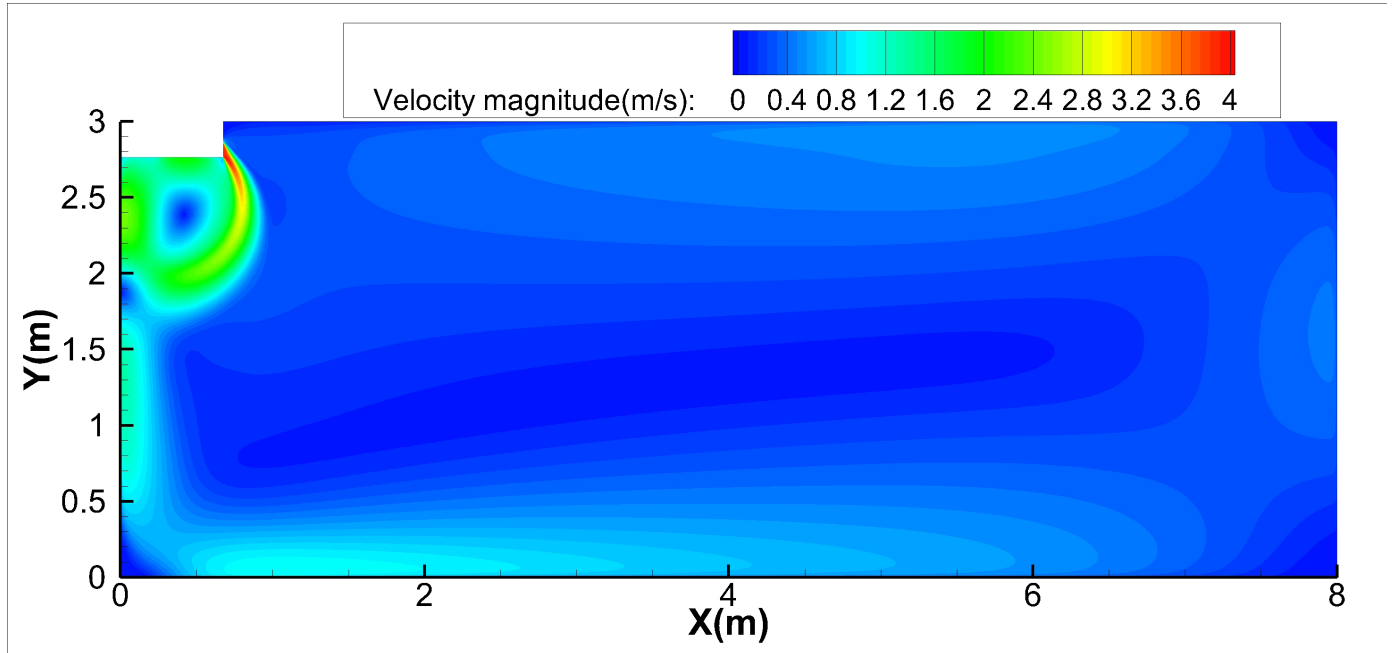

Cooling temperature distributions

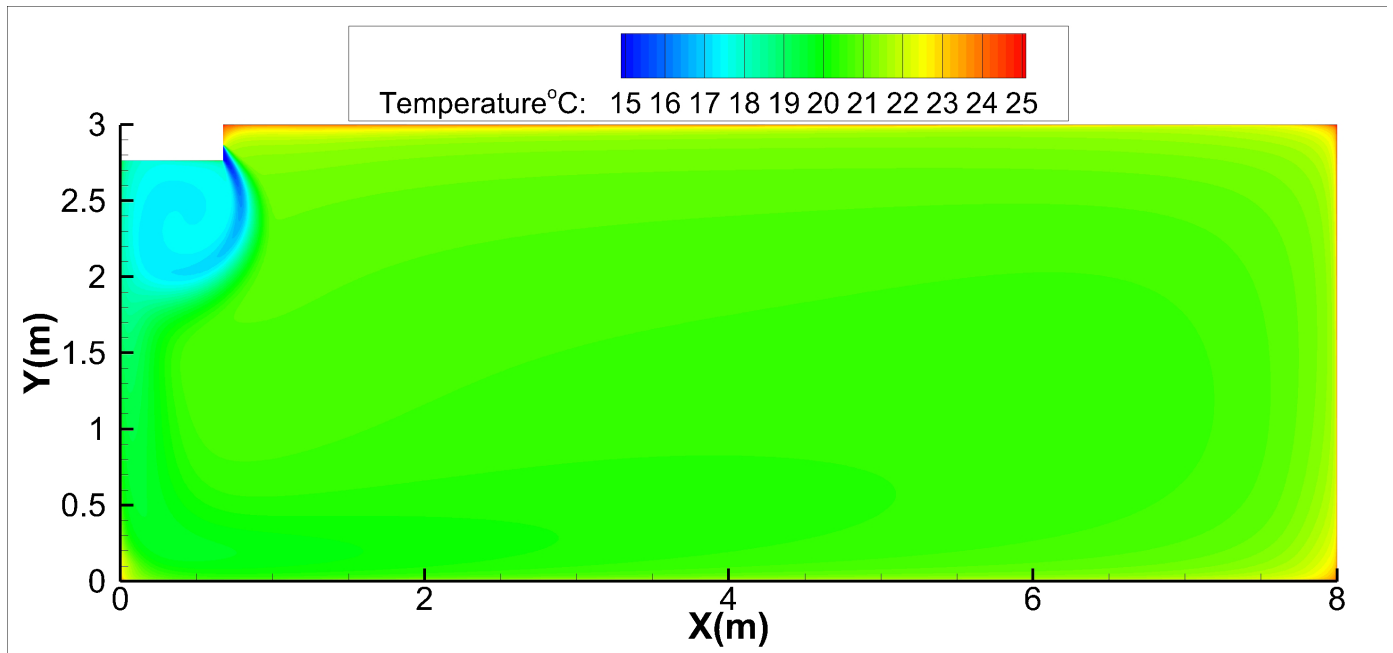

### Floor Ceiling Type -24k

Ceiling installation:

Discharge Angle 30°

Heating airflow velocity distributions

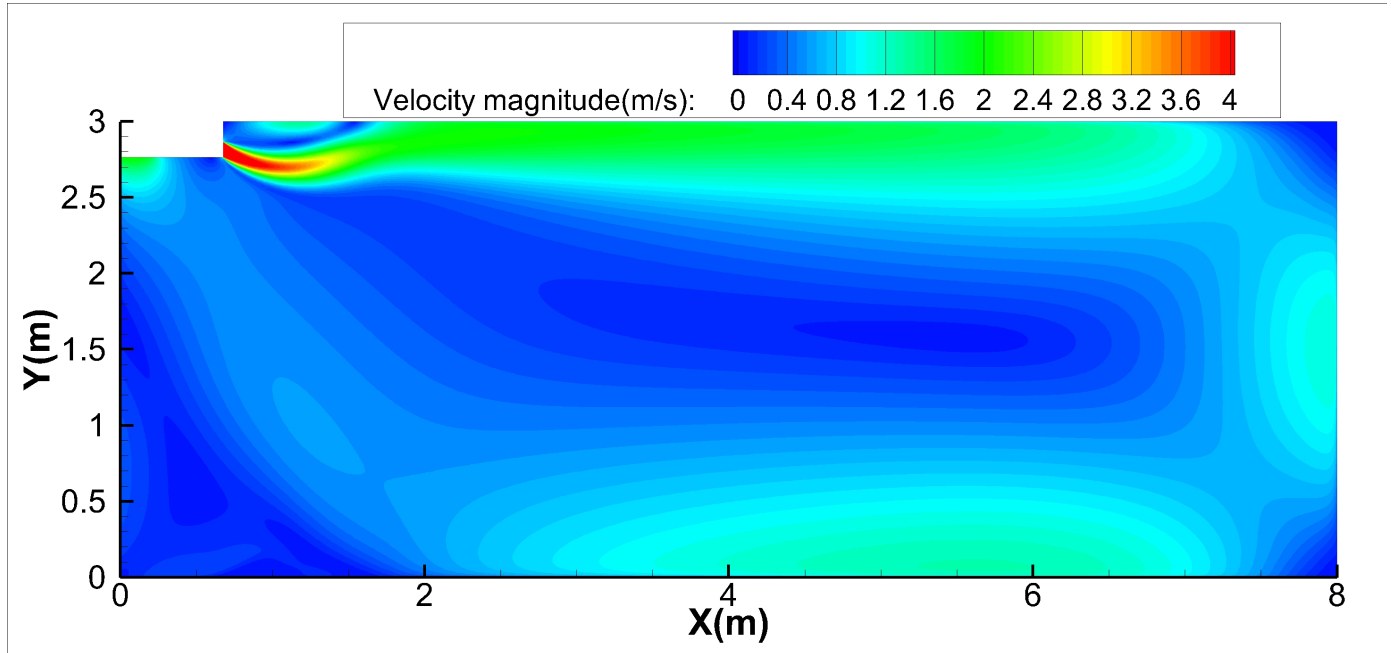

Specifications

Heating temperature distributions

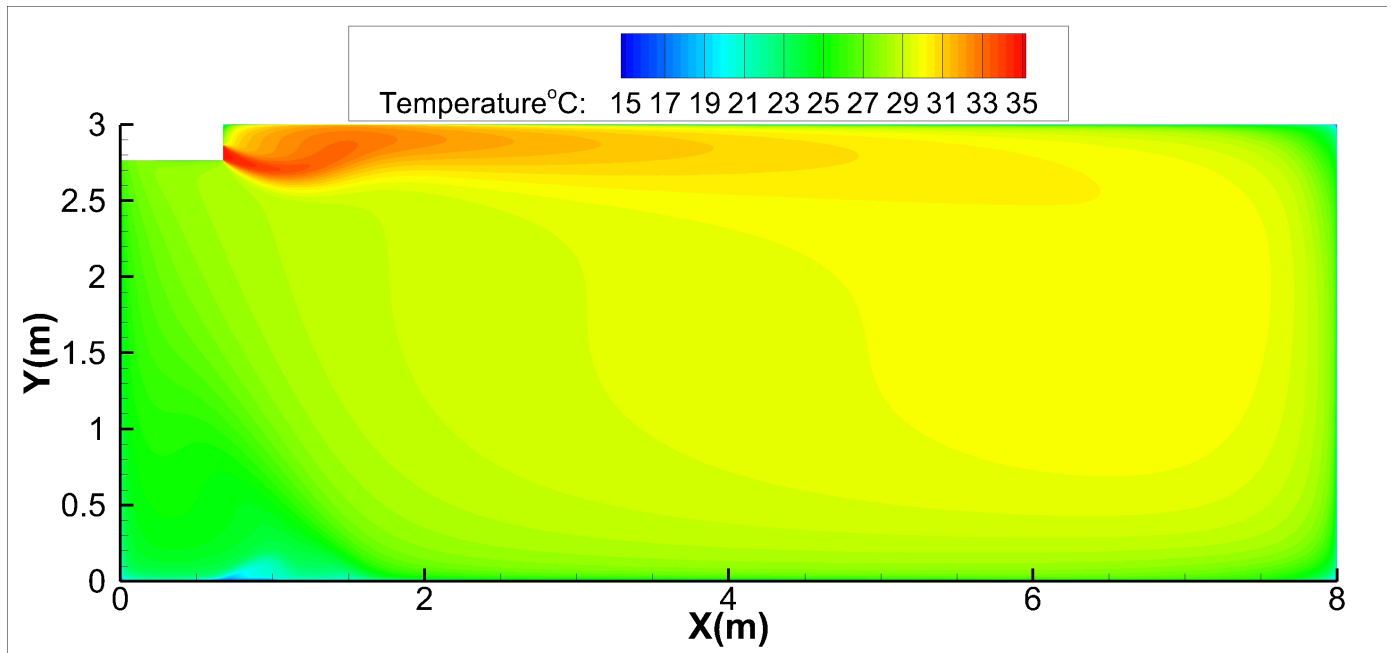

### Floor Ceiling Type -24k

Ceiling installation:

Discharge Angle 60°

Heating airflow velocity distributions

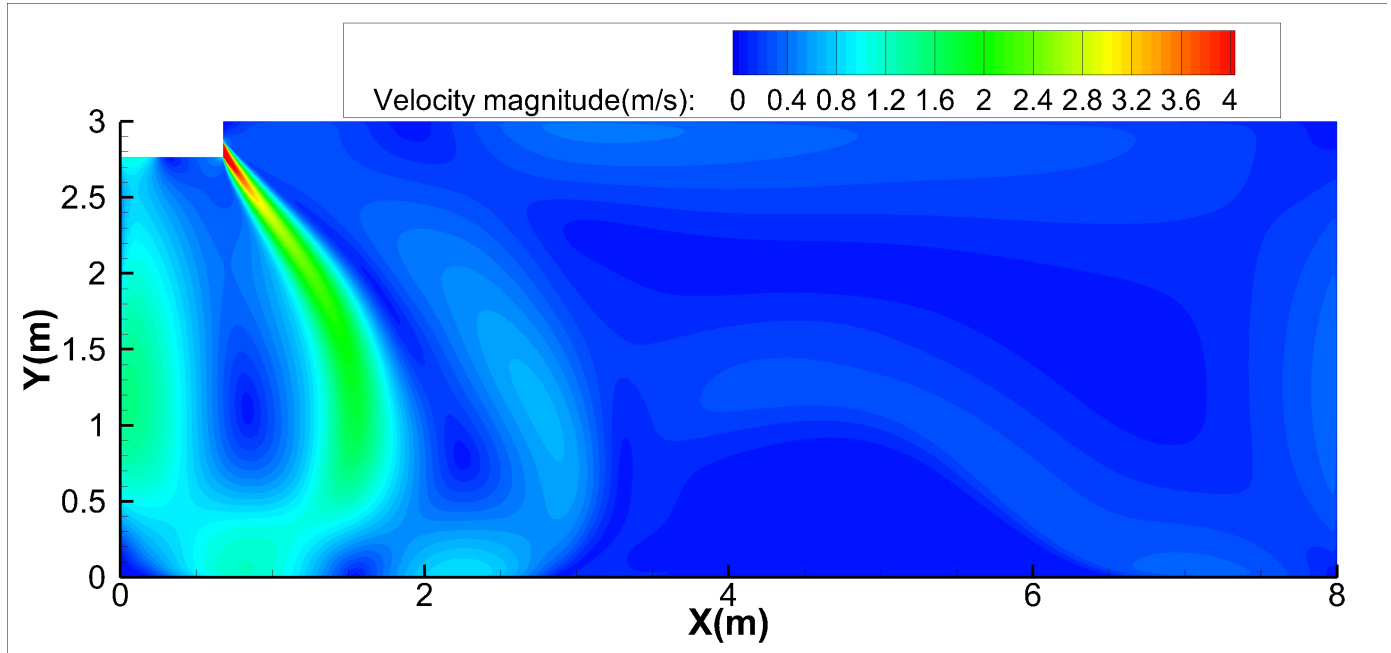

Heating temperature distributions

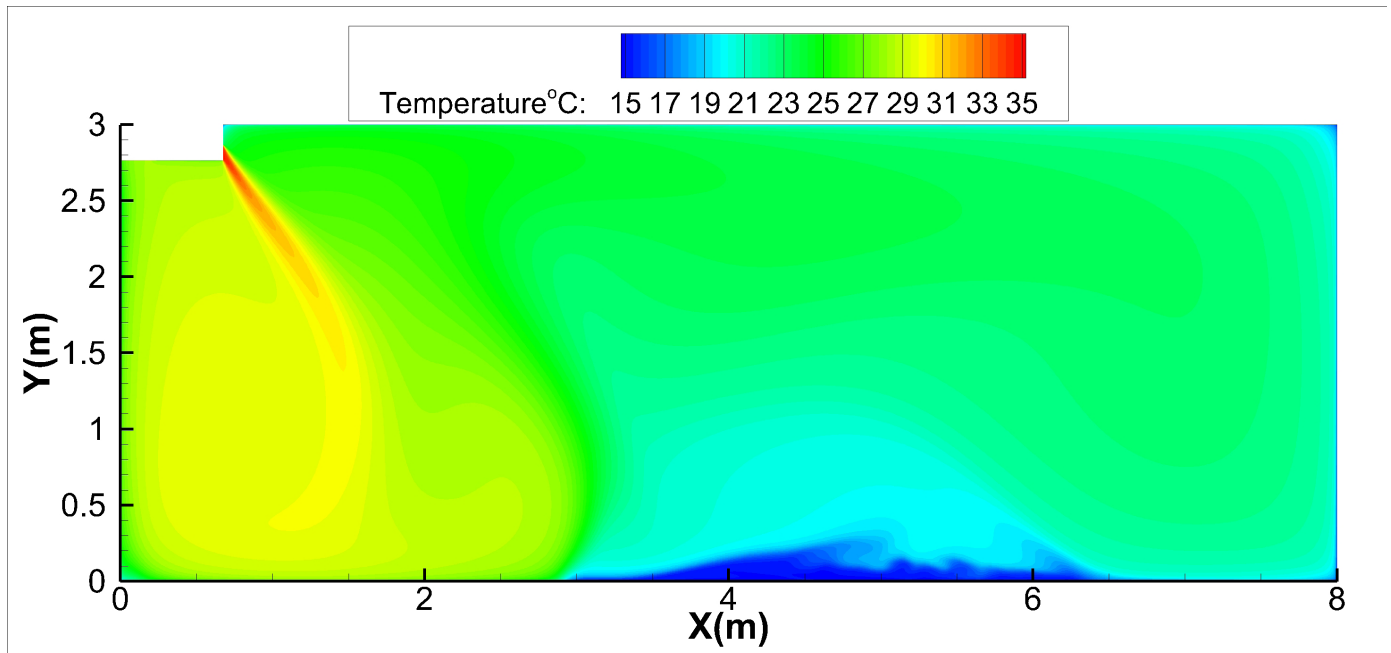



### Floor Ceiling Type -24k

Floor installation:

Discharge Angle 30°

Cooling airflow velocity distributions

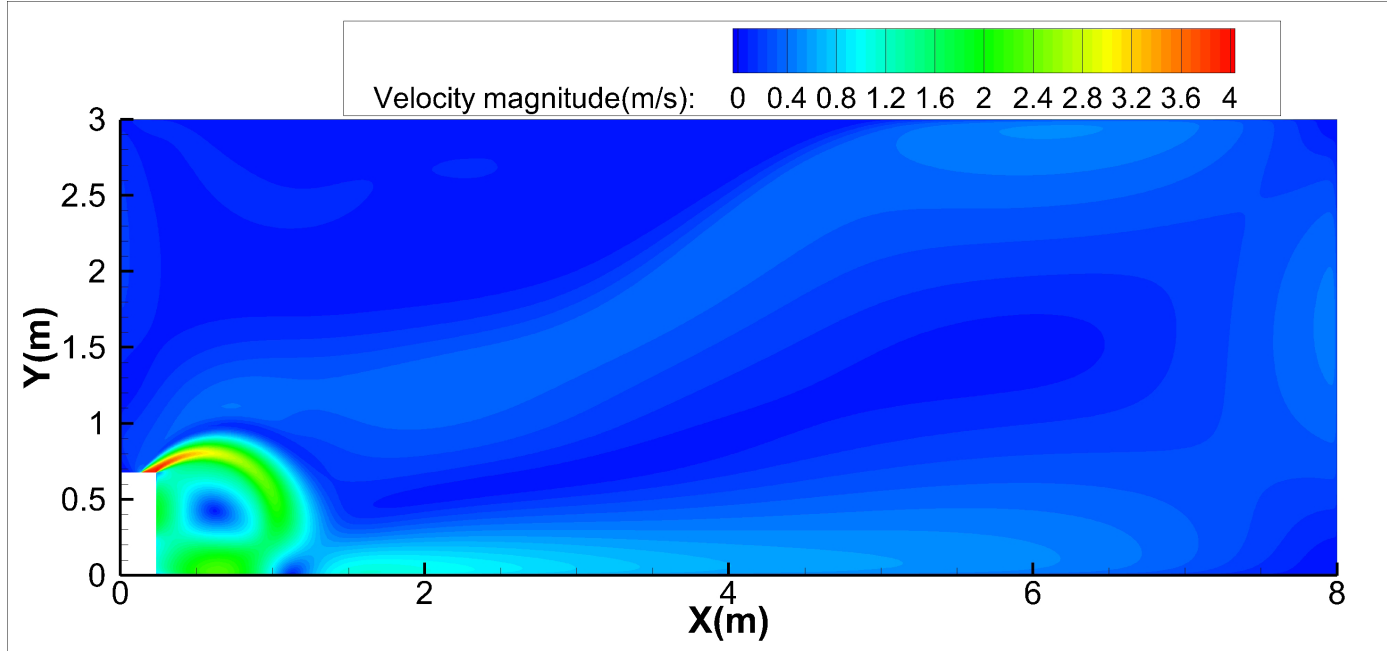

Specifications

Cooling temperature distributions

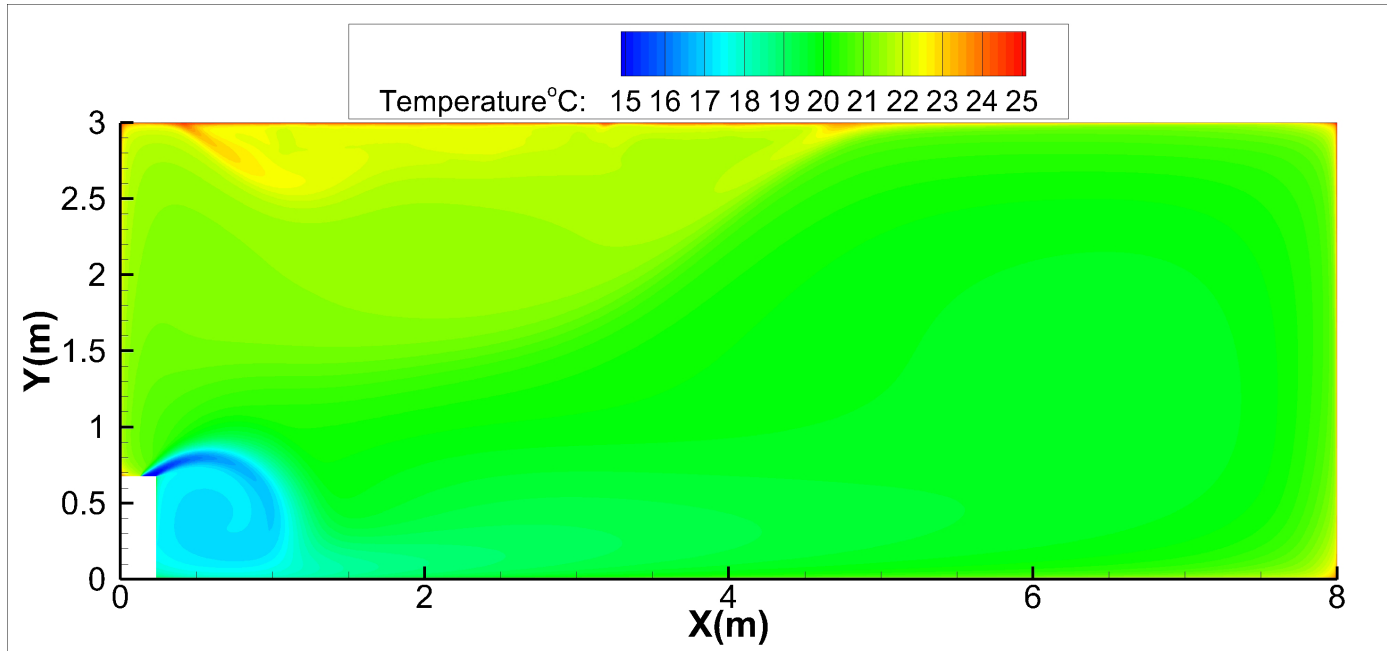

## Floor Ceiling Type -24k

Floor installation:

Discharge Angle 60°

Cooling airflow velocity distributions

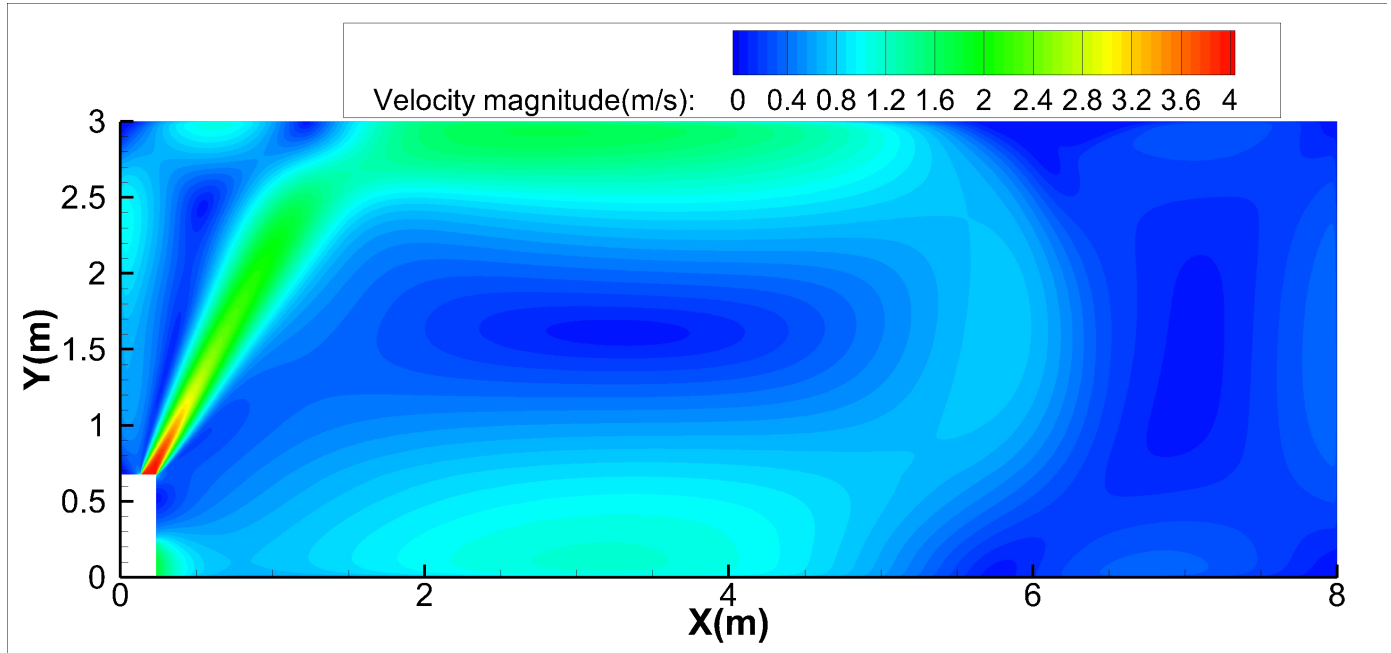

Cooling temperature distributions

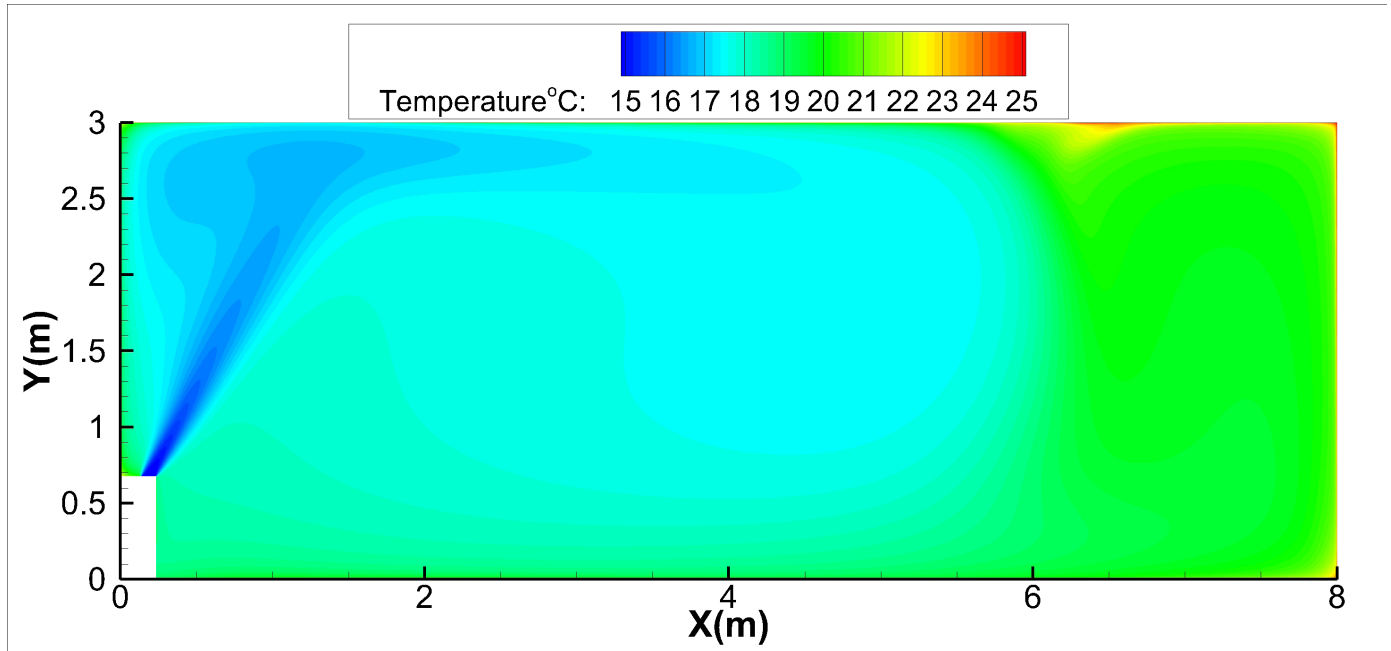

## Floor Ceiling Type -24k

Floor installation:

Discharge Angle 30°

Heating airflow velocity distributions

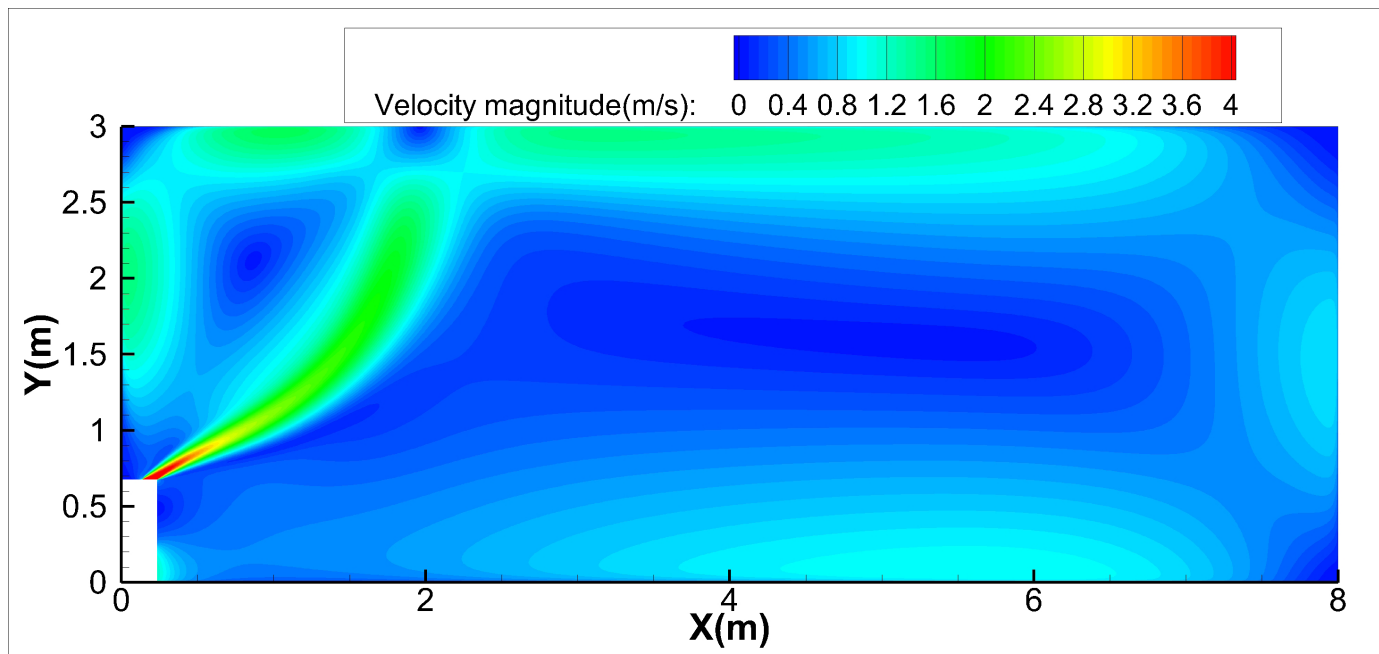

Heating temperature distributions

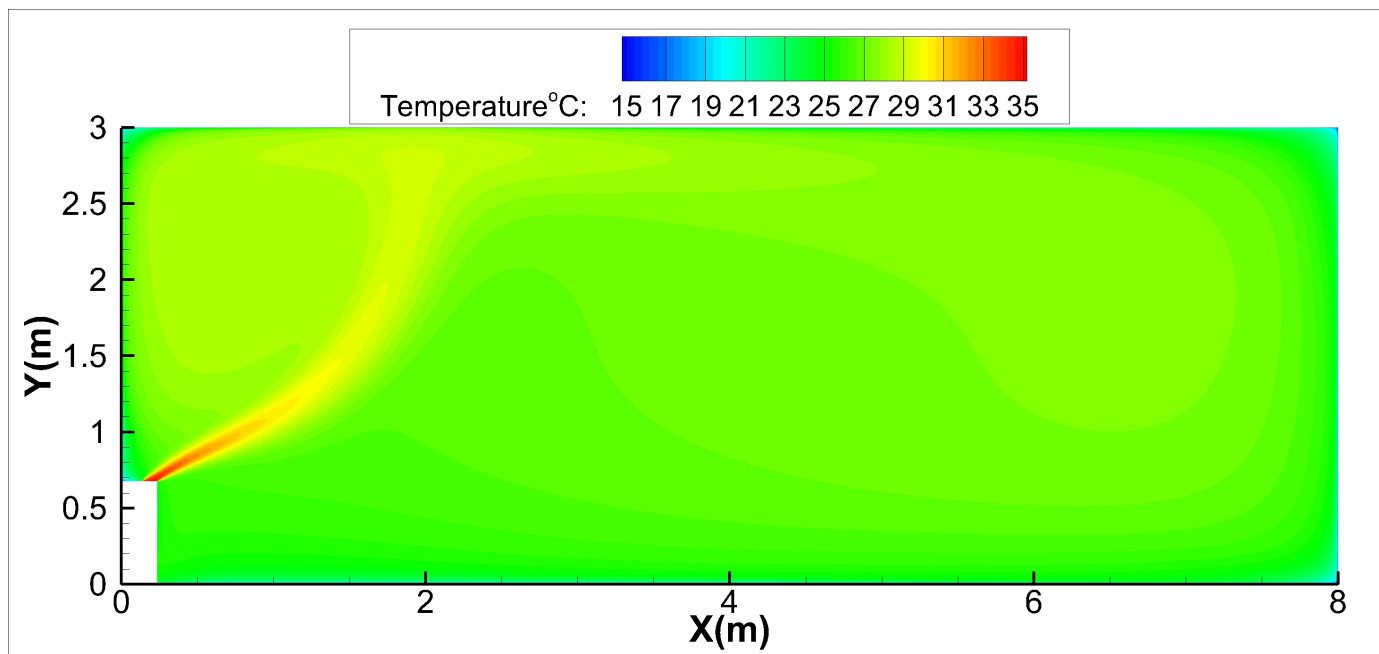

## Floor Ceiling Type -24k

Floor installation:

Discharge Angle 60°

Heating airflow velocity distributions

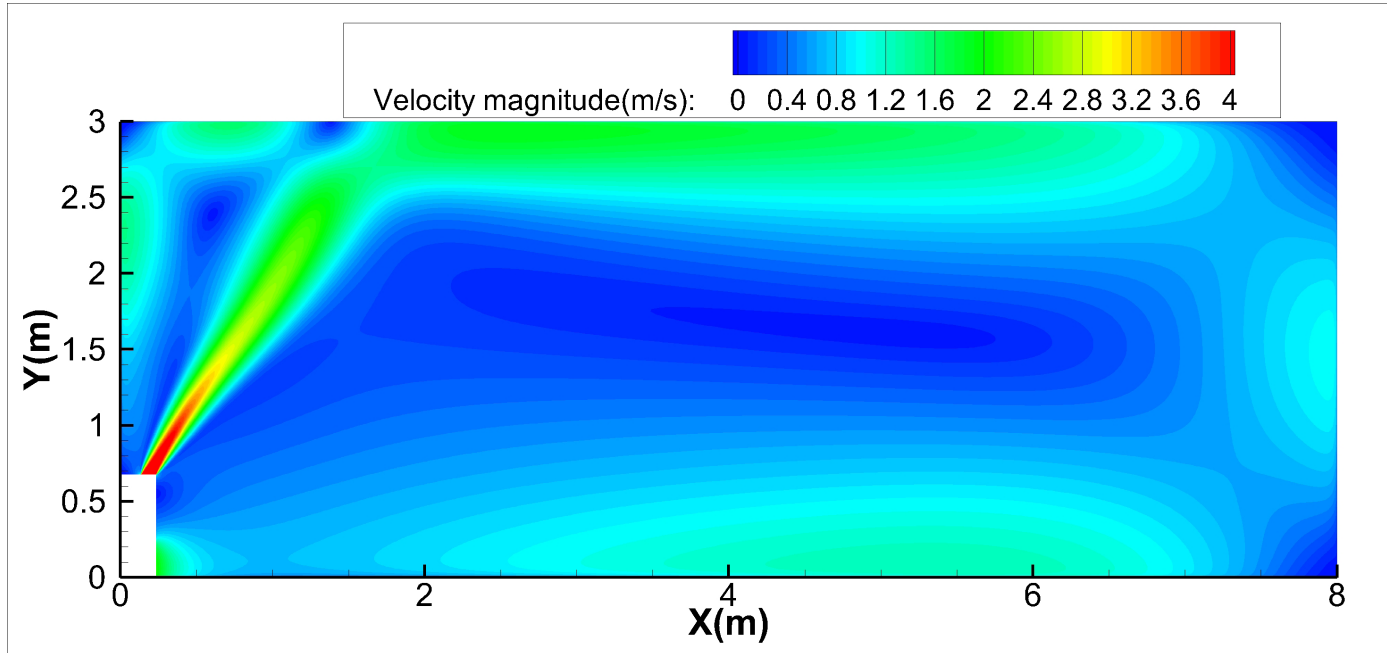

Heating temperature distributions

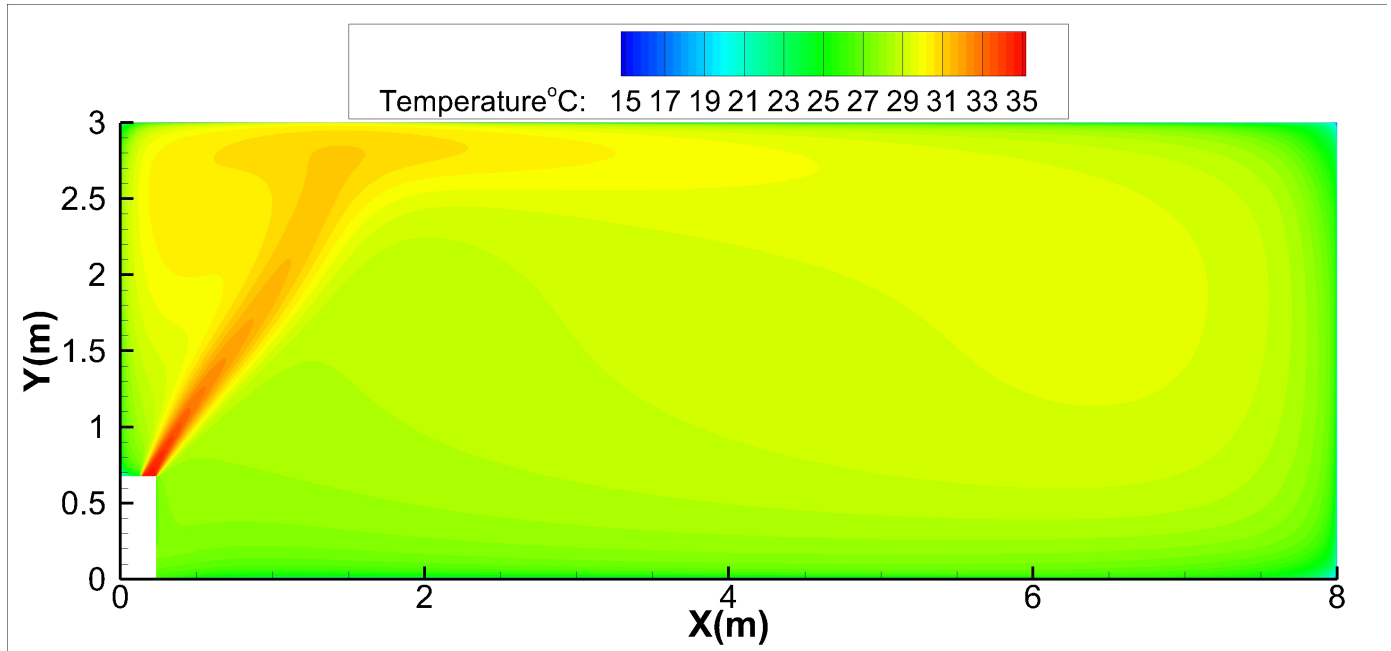

# 10. Electrical Wiring Diagrams

## 10.1 Indoor unit

### A6 Duct type

MTIU-09HWFN1-M, MTIU-12HWFN1-M, MTIU-18HWFN1-M, MTIU-24HWFN1-M

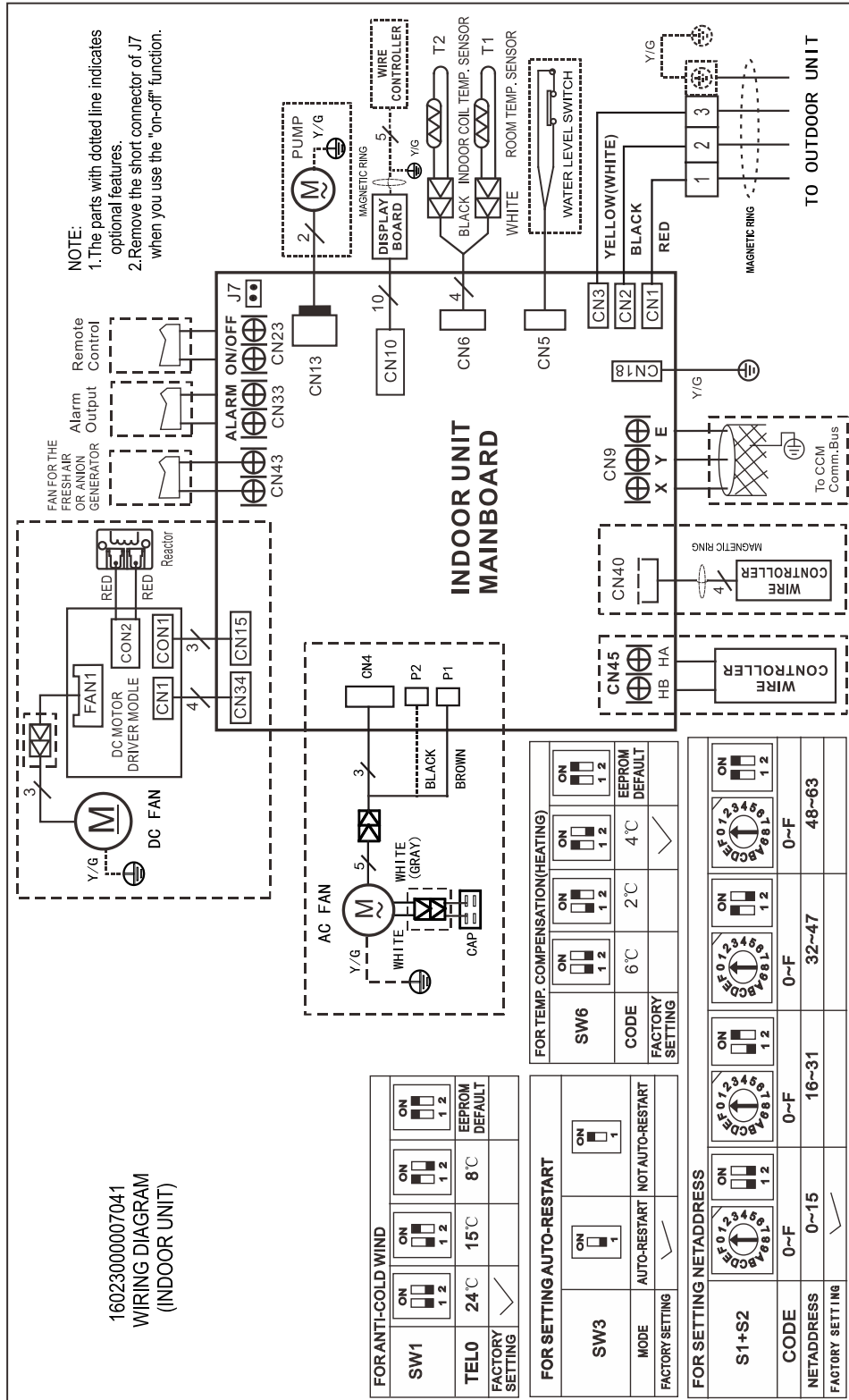



**Compact Cassette type:**

MUEU-18HRFN1-M(C), MUEU-24HRFN1-M(C)

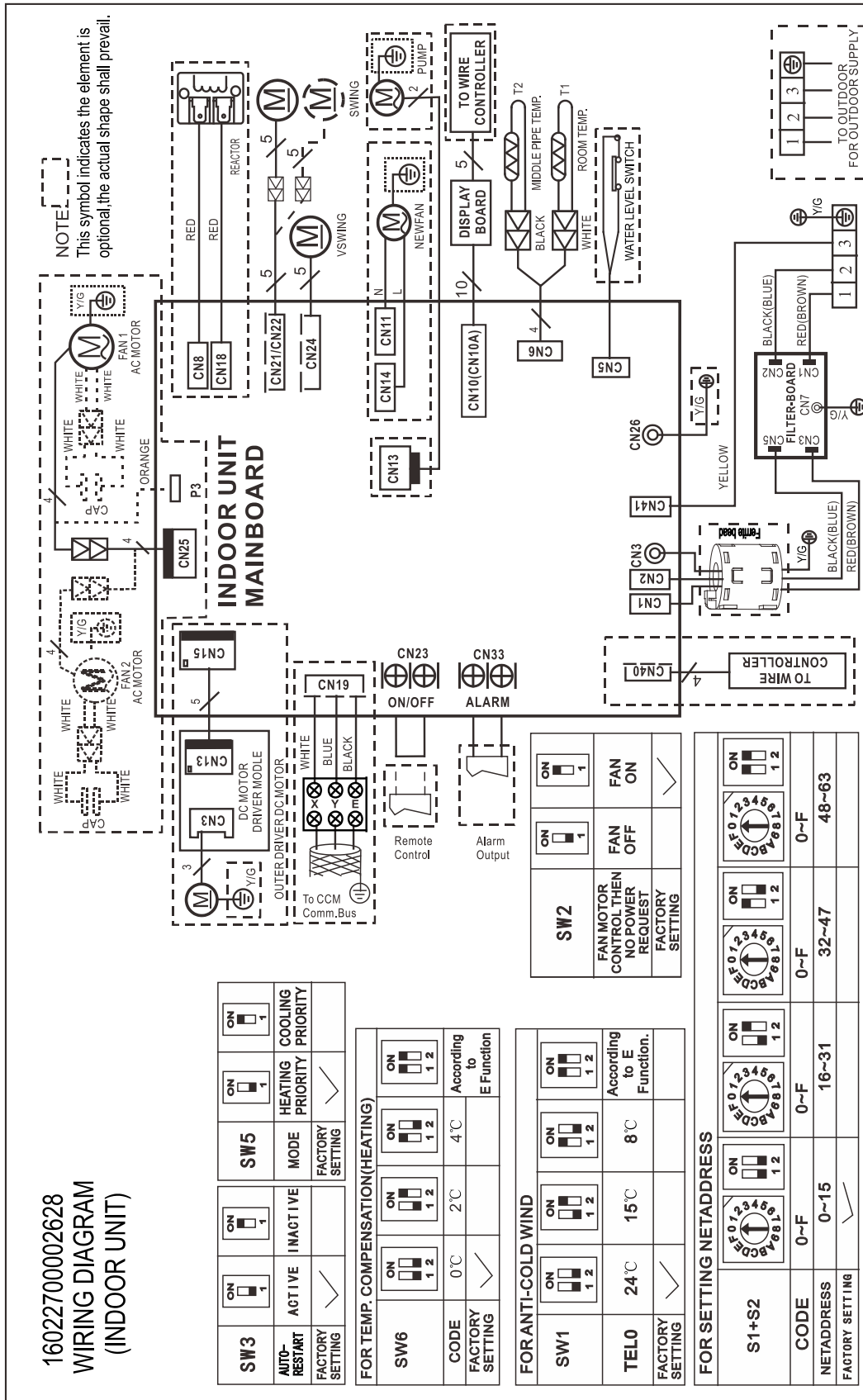

Wall mounted type

MSABB-09HRFN1-MTOW, MSABB-12HRFN1-MTOW, MSABE-18HRFN1-MTOW, MSABE-24HRFN1-MTOW

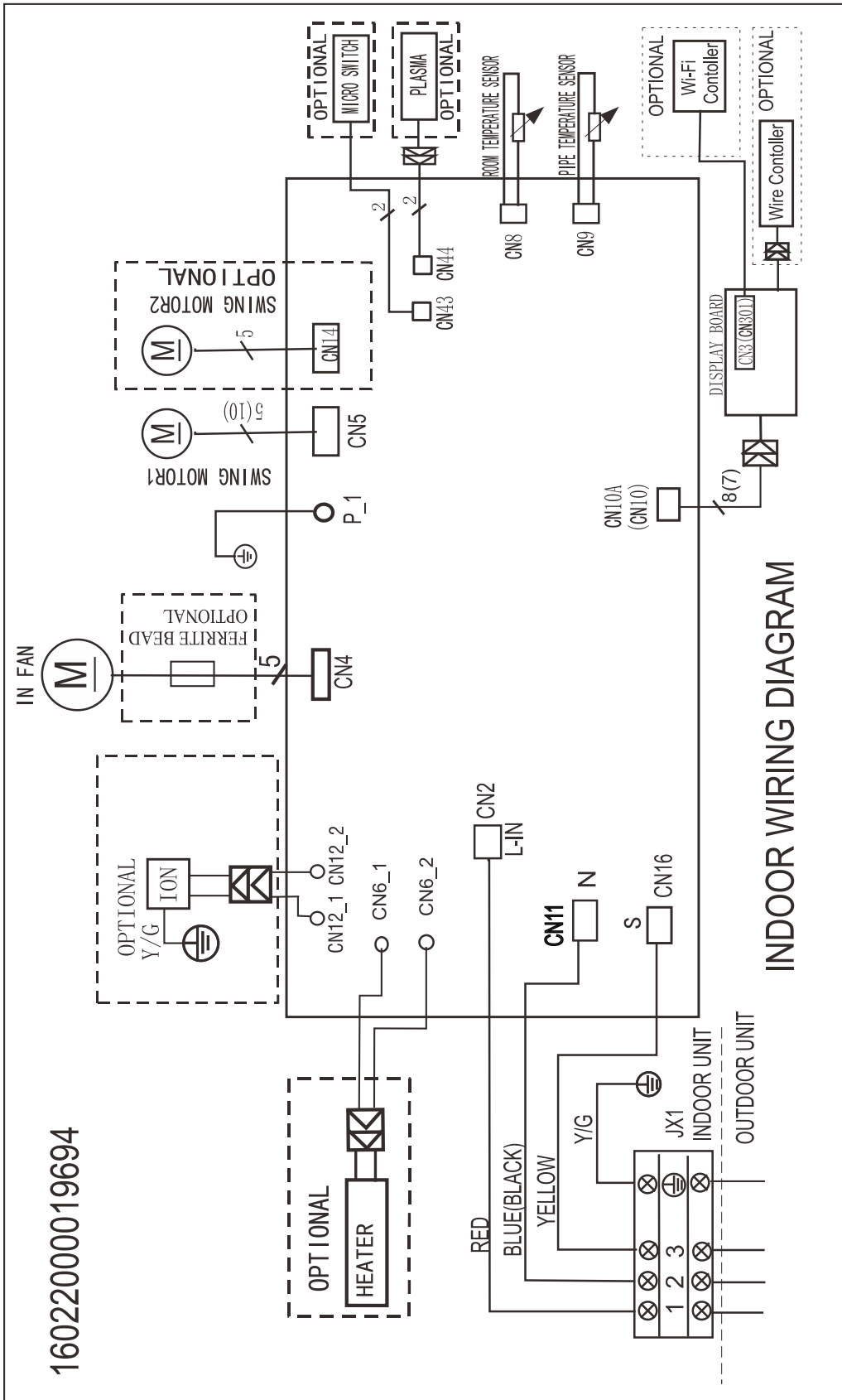





16022300000835

- Notes:
- - - This symbol indicates the element is optional, the actual shape shall be prevail.
  - - - This symbol indicates field wiring.

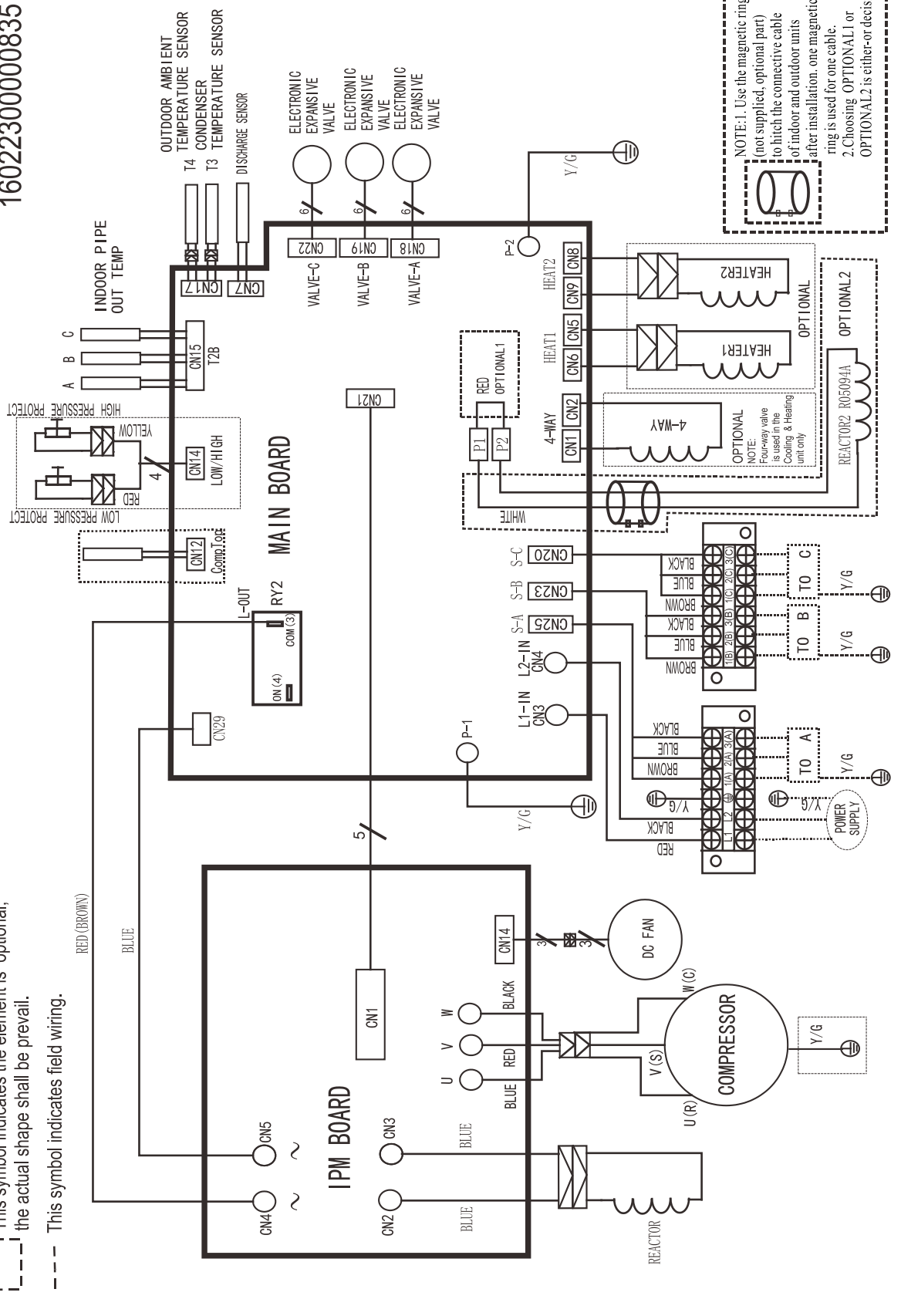

NOTE: 1. Use the magnetic ring (not supplied, optional part) to hitch the connective cable of indoor and outdoor units after installation, one magnetic ring is used for one cable.  
 2. Choosing OPTIONAL1 or OPTIONAL2 is either-or decision

NOTE: Four-way valve is used in the Cooling & Heating unit only



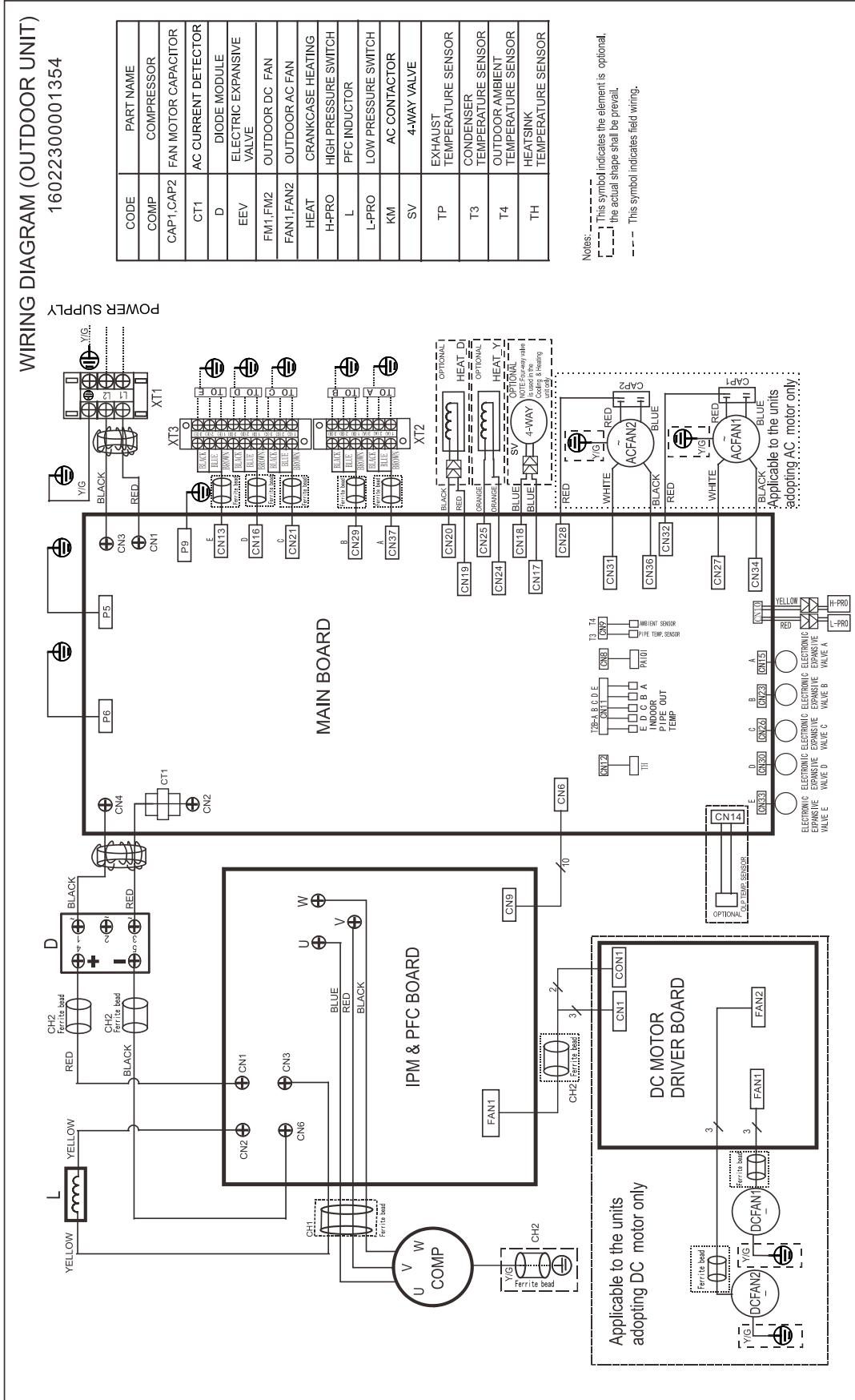

### 10.3 Outdoor Unit PCB Board

Main PCB board of M2OF-18HFN1-M, M3OF-27HFN1-M

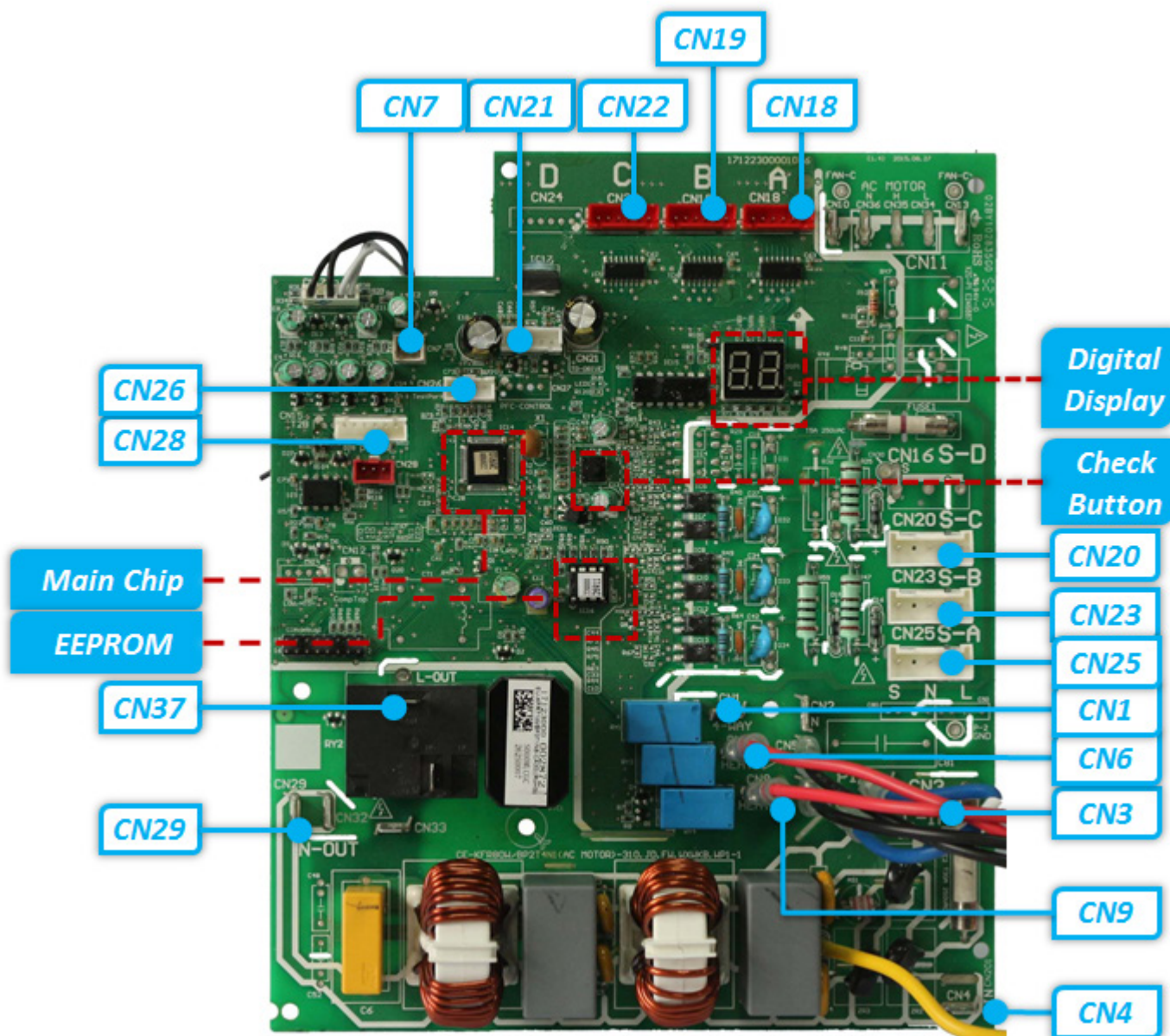

Port	Description	Parameter
CN20	Power and communication with IDU C	230V/AC
CN23	Power and communication with IDU B	230V/AC
CN25	Power and communication with IDU A	230V/AC
CN1	Power output for 4-way valve	230V/AC
CN6	Power output for compressor heater	230V/AC
CN3	Port for L-in	230V/AC
CN9	Power output for chassis heater	230V/AC
CN4	Port for N-in	

CN29	N-out for IPM board	
CN37	L-out for IPM board	230V/AC
CN28	Power output for evaporator outlet (T2B) temperature sensor	5V/DC
CN26	Port for test board	5V/DC
CN7	Power output for discharge (T5) temperature sensor	12V/DC
CN21	Power output for condenser (T3), ambient (T4) temperature sensors	5V/DC
CN22	Power output for EEV C	0-200V/AC
CN19	Power output for EEV B	
CN18	Power output for EEV A	



Port	Description	Parameter
CN14	Output for DC fan	
CN1	Communication port with main board	5V, 12V/DC
CN2	Connection ports for reactor	320V/DC
CN3		
CN5	N port for AC input	5V/DC
CN4	L port for AC input	230V/AC

Main PCB board of M4OF-36HFN1-M

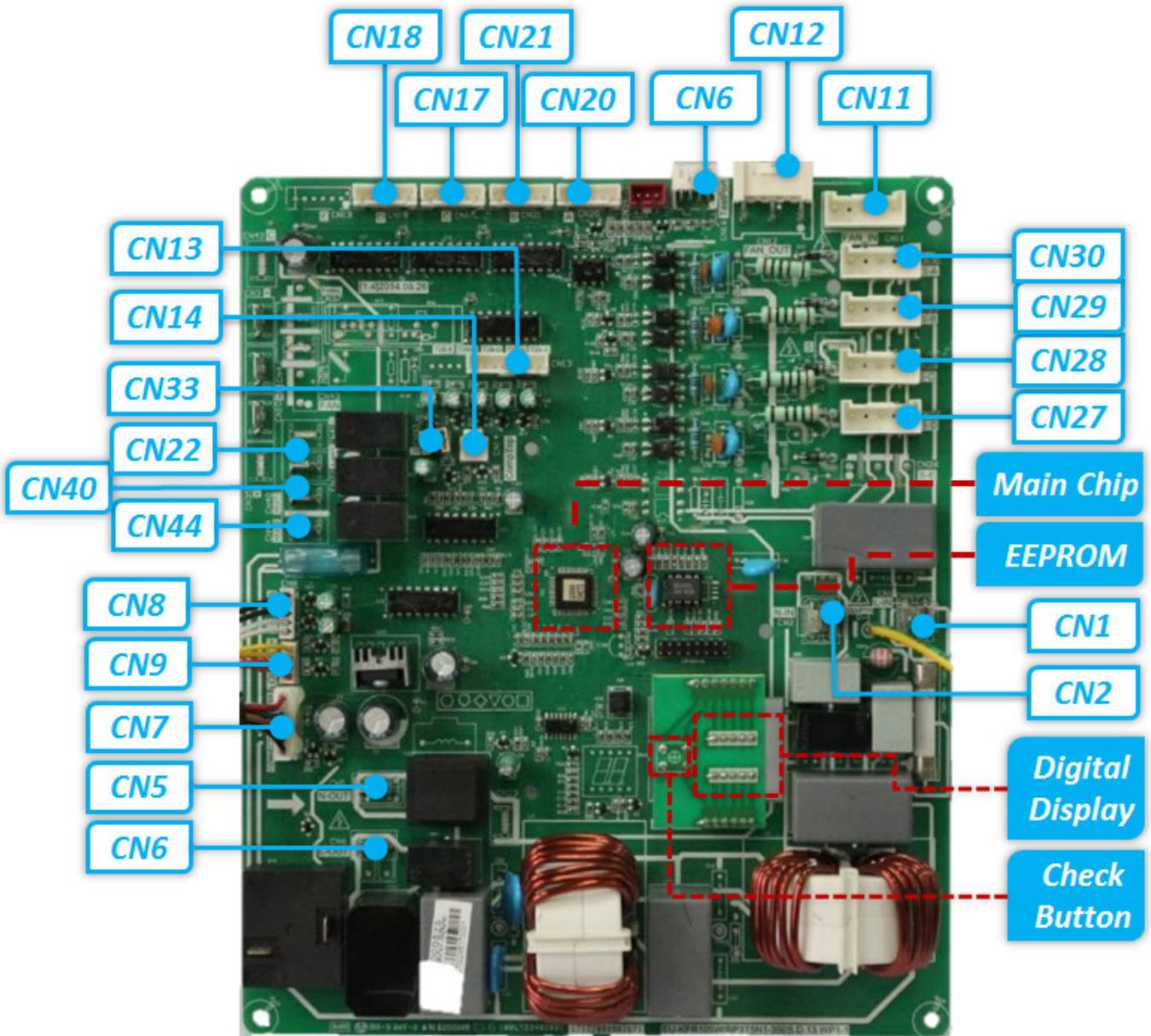



Port	Description	Parameter
CN27-30	Power and communication with IDU A-D	230V/AC
CN1, CN2	Power input for this PCB	230V/AC
CN6, CN5	Power output for IPM board	230V/AC
CN7	Port for communication with IPM board	5V/DC
CN9	Port for Hi-pressure and low-pressure switches	
CN8	Power output for condenser (T3), ambient (T4) temperature sensors	5V/DC
CN44	Power output for compressor heater	230V/AC
CN40	Power output for chassis heater	230V/AC
CN22	Power output for 4-way valve	230V/AC
CN33	Power output for discharge (T5) temperature sensor	5V/DC
CN14	Port for compressor top high temperature protector	
CN13	Power output for evaporator (T2B) temperature sensor of IDU A-D	5V/DC
CN17-21	Power output for EEV A-D	12V/DC
CN6	Port for test board	5V/DC
CN12	Output for DC fan	
CN11	Input for DC Fan	

IPM board of M4OF-36HFN1-M

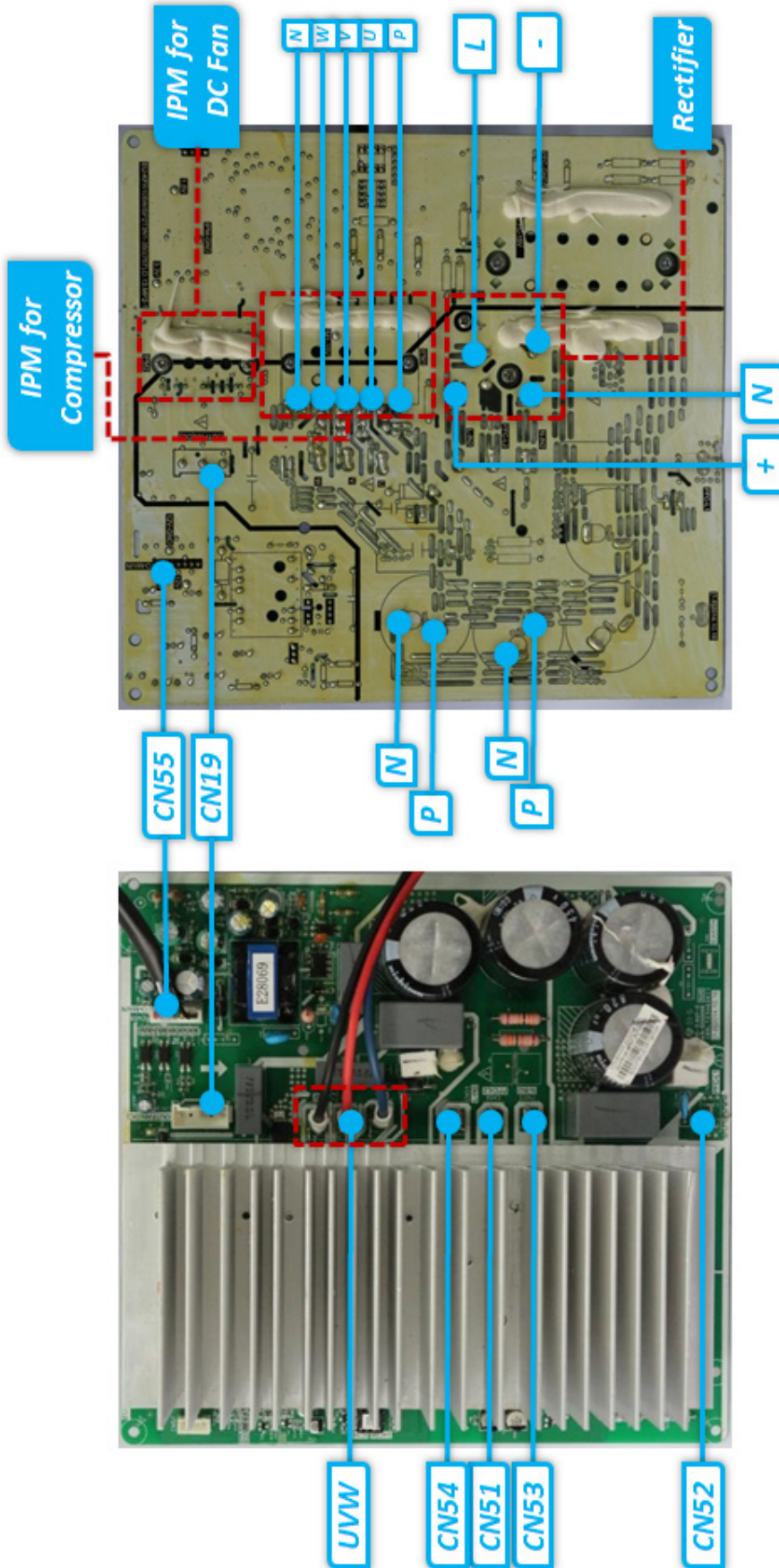

Port	Description	Parameter
CN19	Output for DC fan	
CN55	Communication port with main board	5V, 12V/DC
CN51	Connection ports for reactor	320V/DC
CN52		
CN53	N port for AC input	5V/DC
CN54	L port for AC input	230V/AC
UVW	Output for compressor	

Main PCB board of M5OF-48HFN1-M

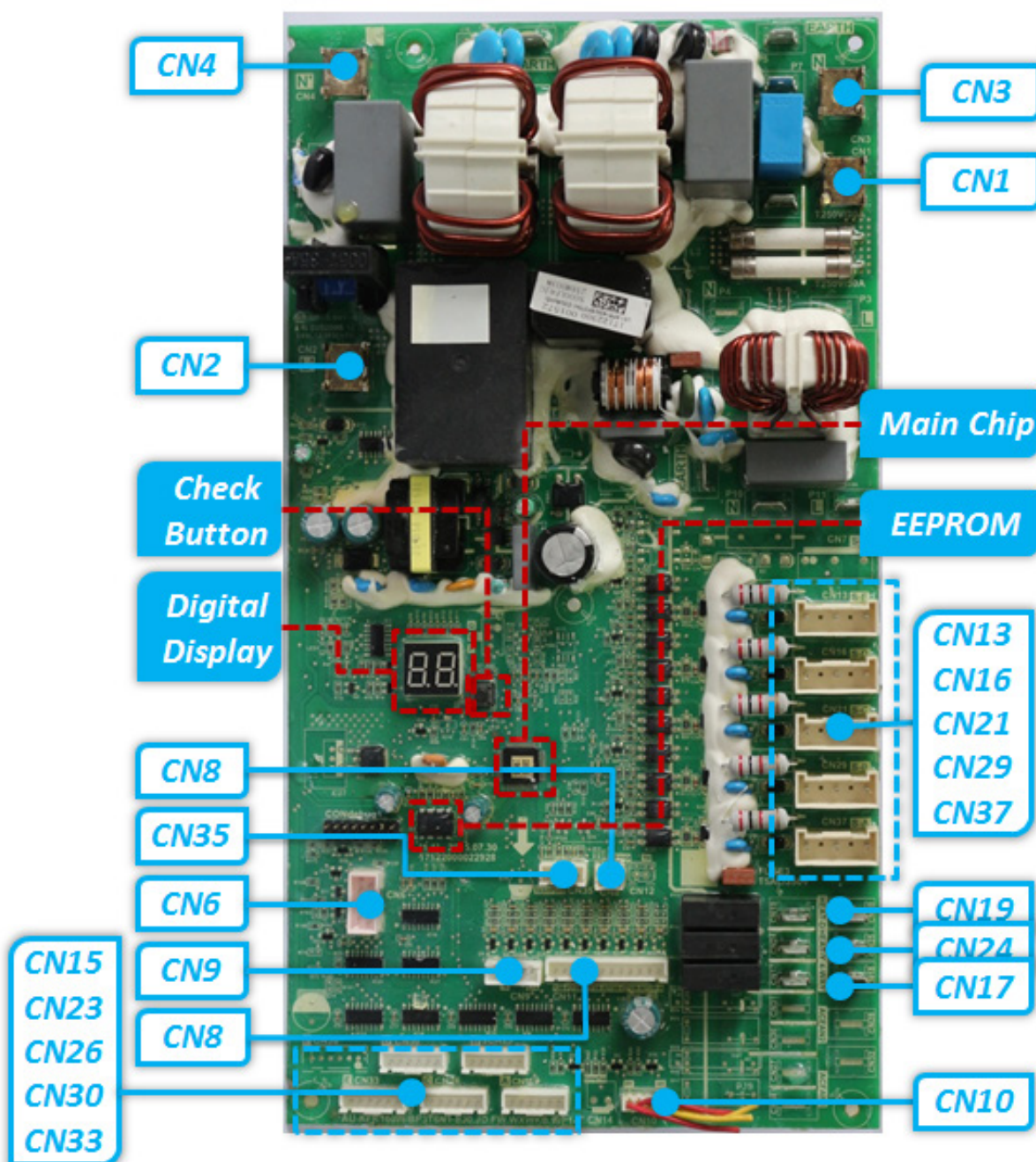

Port	Description	Parameter
CN1, 3	Power input of the PCB	230V/AC
CN2, 4	Power output for IPM board	230V/AC
CN22	Port for communication with indoor unit	
CN35	Port for test board	5V/DC
CN6	Port for communication with IPM board	5V/DC
CN9	Power output for condenser (T3), ambient (T4) temperature sensors	5V/DC
CN8	Power output for discharge (Td) temperature sensor	5V/DC
CN15, 23, 26, 30, 33	Power output for EEV of IDU A-E	12V/DC
CN10	Port for Hi-pressure and low-pressure switches	
CN17	Power output for 4-way valve	230V/AC
CN24	Power output for compressor heater	230V/AC
CN19	Power output for chassis heater	230V/AC
CN13, 16, 21, 29, 37	Power and communication with IDU A-D	230V/AC

IPM board of M5OF-48HFN1-M

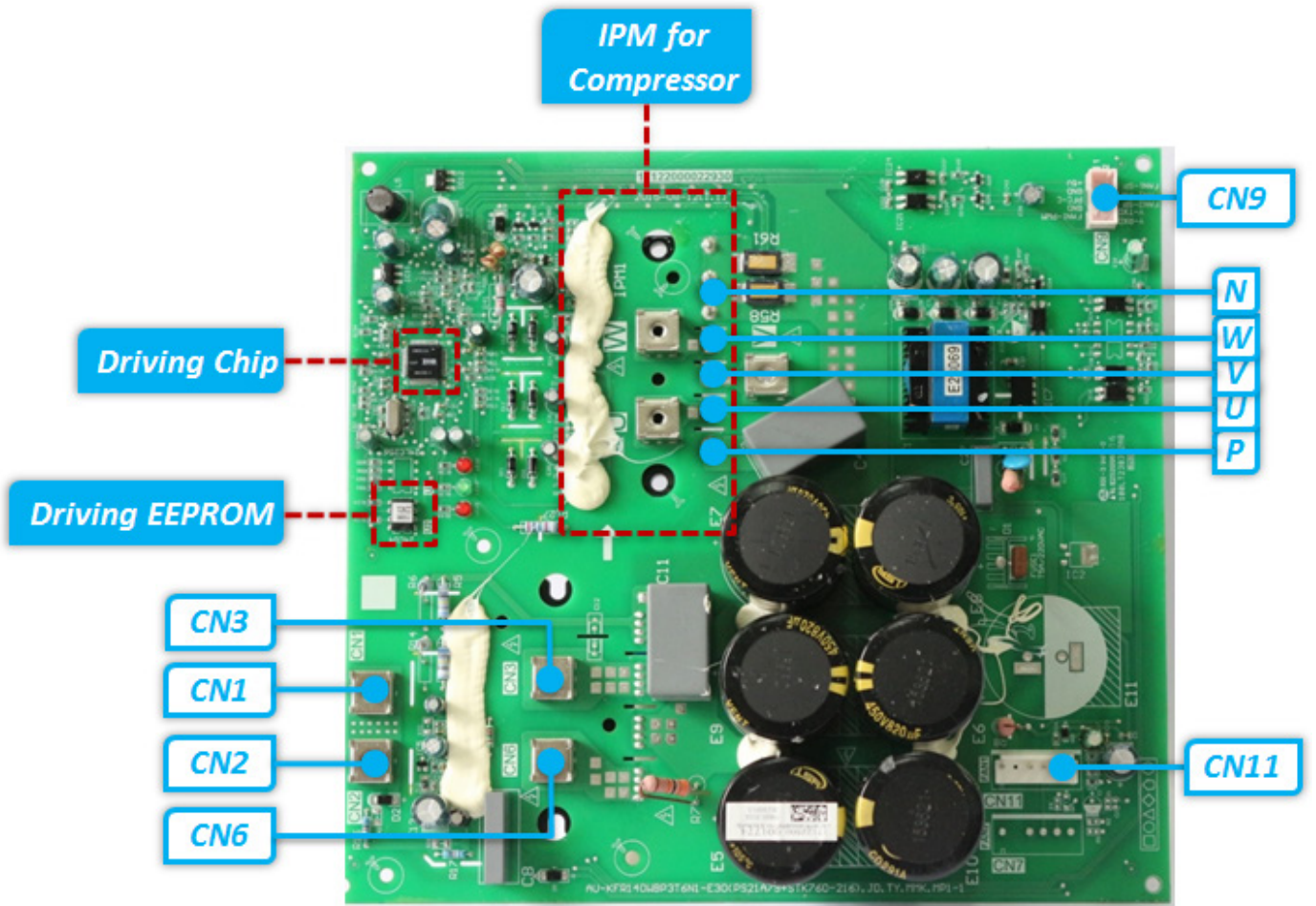

Specifications

Port	Description	Parameter
CN11	Output for DC fan drive board	230V/AC
CN9	Communication port with main board	5V/DC
CN1	P-in	320V/DC
CN2	N-in (GND)	
CN3, CN6	Ports for reactor	
UVW	Output for compressor	

DC fan drive board of M5OF-48HFN1-M

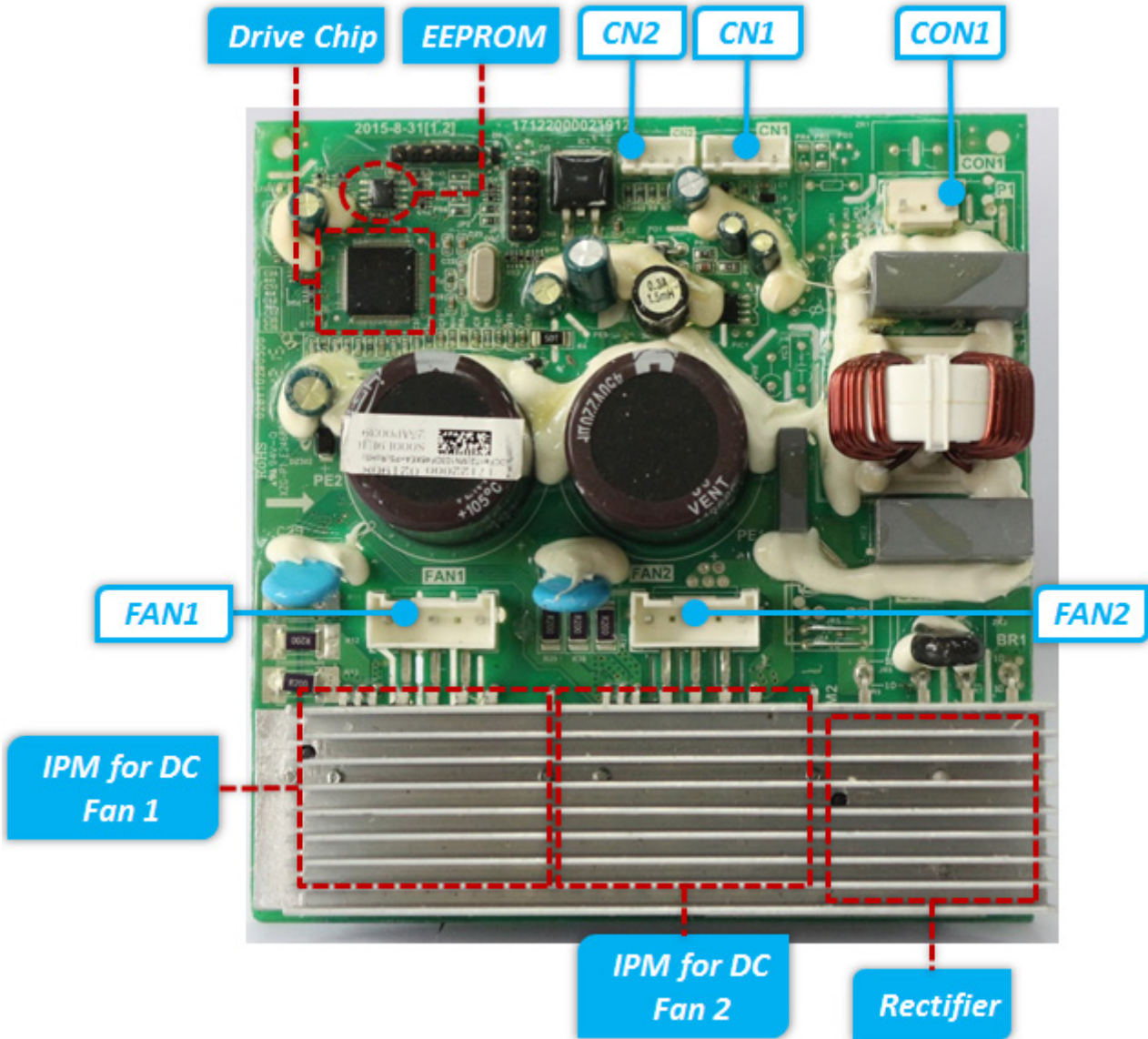

Port	Description	Parameter	Remark
CON1	Power input for the PCB	230V/AC	
CN1	Communication with main PCB	230V/AC	
CN2	Test port	5V/DC	For debugging board
CN23	UVW output for DC fan motor 1		
CN23	UVW output for DC fan motor 2		

## 11. Refrigerant Cycle Diagrams

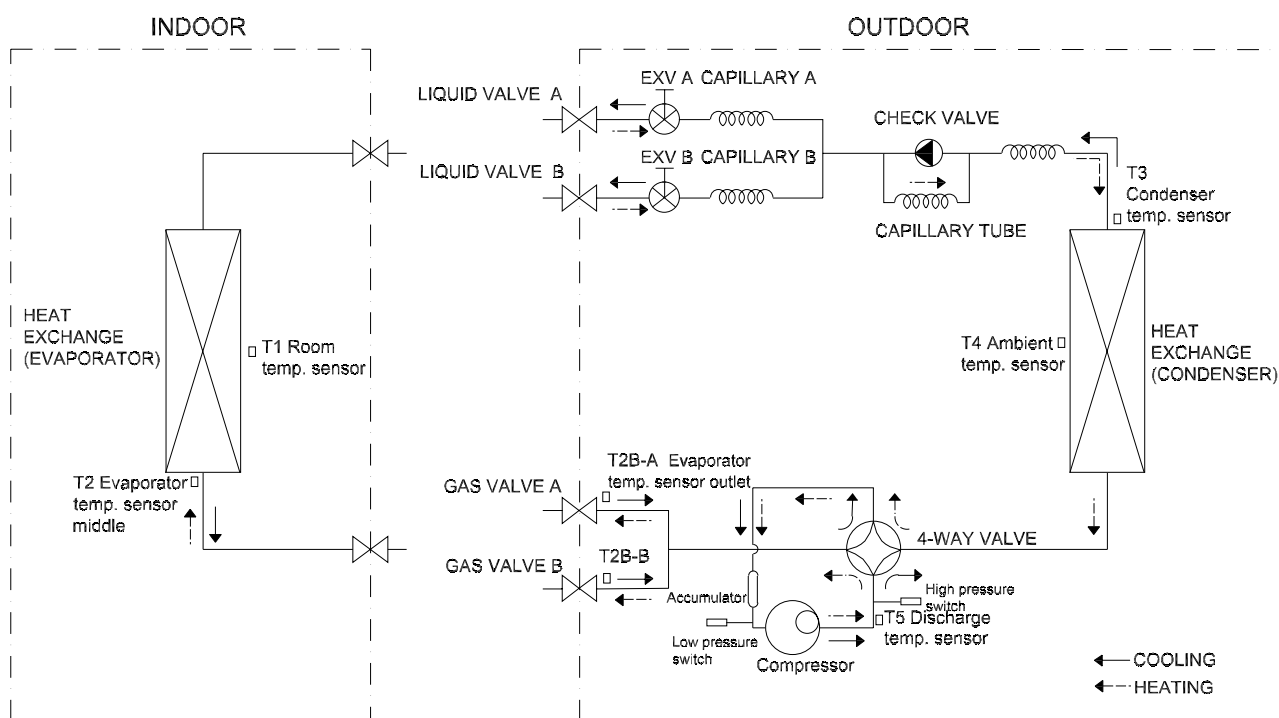

Specifications

Model	Pipe Size (Diameter:ø)		Piping length (m)			Elevation (m)		Additional Refrigerant
	Gas	Liquid	Rated	Max		IDU and ODU	Between IDUs	
				Single	Total			
M2OF-18HFN1-M	2x9.52	2x6.35	15	25	40	15	10	15g/m

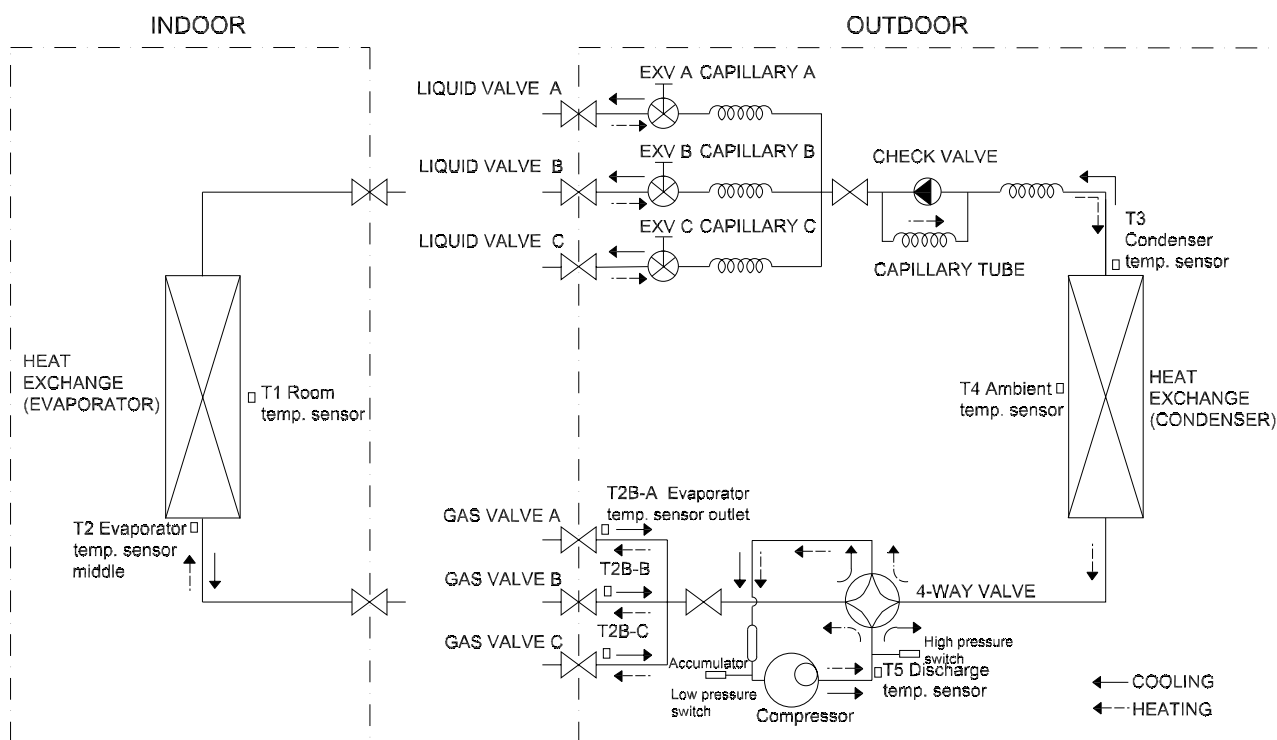

Model	Pipe Size (Diameter:ø)		Piping length (m)			Elevation (m)		Additional Refrigerant
			Rated	Max		IDU and ODU	Between IDUs	
	Gas	Liquid		Single	Total			
M3OF-27HFN1-M	3x9.52	3x6.35	22.5	30	60	15	10	15g/m



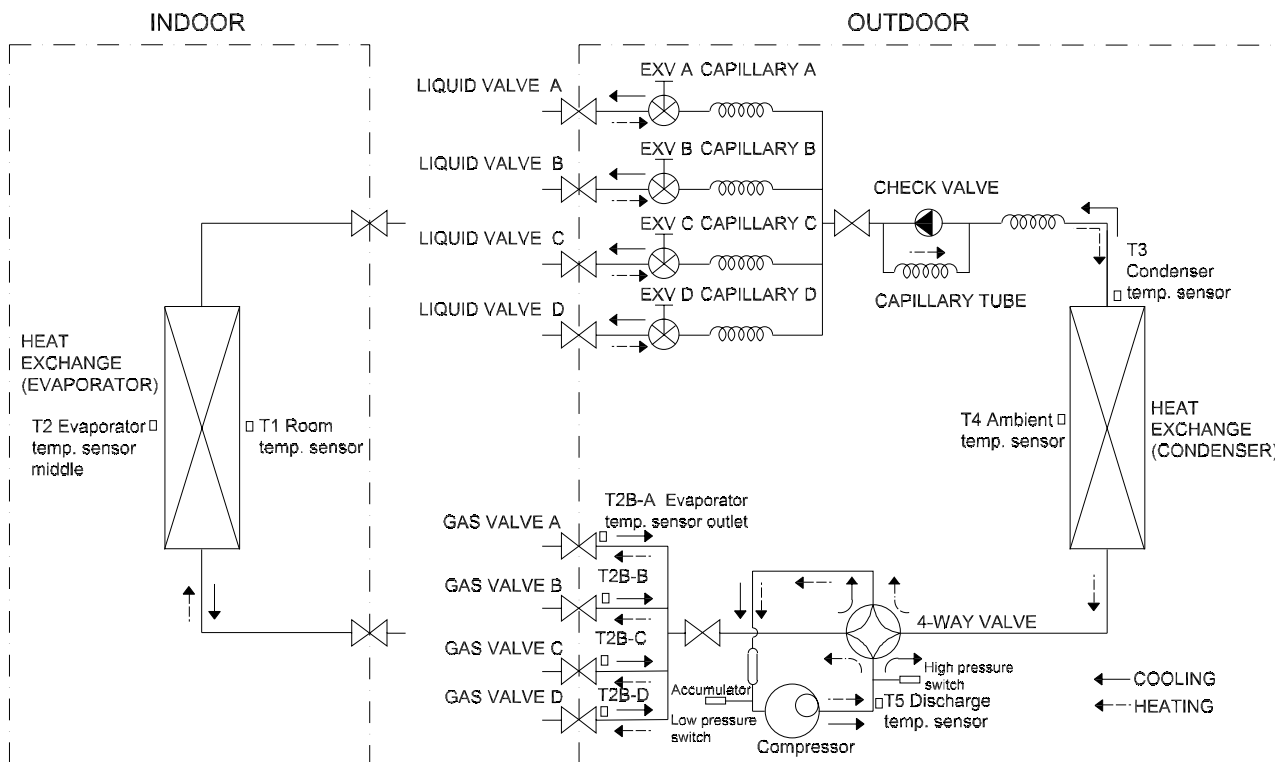

Model	Pipe Size (Diameter:ø)		Piping length (m)			Elevation (m)		Additional Refrigerant
			Rated	Max		IDU and ODU	Between IDUs	
	Gas	Liquid		Single	Total			
M40F-36HFN1-M	3x9.52+1x12.7	4x6.35	30	35	80	15	10	15g/m

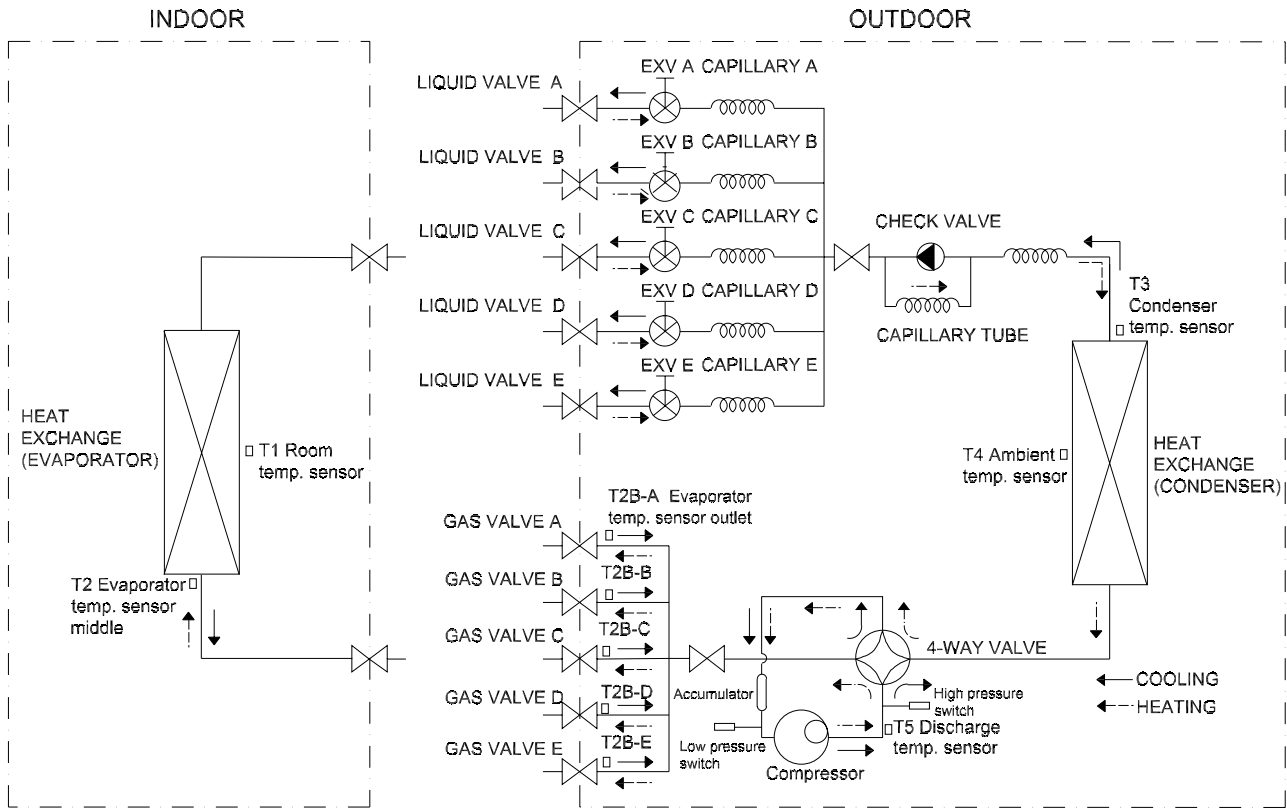

Model	Pipe Size (Diameter:ø)		Piping length (m)			Elevation (m)		Additional Refrigerant
			Rated	Max		IDU and ODU	Between IDUs	
	Gas	Liquid		Single	Total			
M50F-48HFN1-M	3x9.52+2x12.7	5x6.35	37.5	35	80	15	10	15g/m

## 12. Capacity Tables

Zone	Model	Cooling		Outdoor conditions (DB)-F(°C)																				
		Indoor Conditions °F(°C)		TC	-22 (-30)	-13 (-25)	-5 (-20.6)	-4 (-20)	0 (-17.8)	5 (-15)	15 (-9.4)	25 (-3.9)	35 (1.7)	45 (7.2)	55 (12.8)	65 (18.3)	75 (23.9)	85 (29.4)	95 (35)	105 (40.6)	115 (46.1)	122 (50)		
		DB	WB																					
Two Zone	MTIU-09HWFN1-M M20F-18HFN1-M	65(18.3)	54(12.2)	TC	14.41	15.15	16.00	16.10	16.52	16.70	16.85	16.95	17.02	17.09	18.00	19.44	19.66	19.93	19.56	14.61	13.34	10.63		
				SC	10.71	11.34	13.03	13.28	13.14	14.17	13.72	13.06	14.18	14.89	14.25	14.27	14.94	13.98	13.47	11.29	10.16	8.08		
		70(21.1)	59(15)	TC	15.25	16.11	16.74	16.81	17.09	17.30	17.65	17.89	18.10	18.90	19.05	20.68	20.81	21.20	20.69	15.55	14.11	11.31		
				SC	11.39	12.20	13.87	14.20	13.98	14.99	14.60	13.99	14.86	15.54	15.41	15.26	15.64	14.80	14.25	12.01	10.76	8.60		
		75(23.9)	63(17.2)	TC	15.88	16.70	17.53	17.60	18.24	18.33	18.60	18.76	18.89	19.35	20.38	21.65	22.14	22.20	21.67	16.64	14.66	11.84		
				SC	12.25	13.05	14.75	14.75	14.64	16.03	15.29	15.04	15.48	16.10	16.00	15.98	16.13	15.66	15.16	12.71	11.44	9.10		
		80(26.7)	67(19.4)	TC	16.55	17.30	18.26	18.43	18.81	19.19	19.25	19.66	19.72	20.92	21.79	22.67	23.55	23.25	22.69	17.82	15.22	12.40		
				SC	12.96	13.88	15.61	15.69	15.49	16.80	15.96	16.26	16.56	16.86	16.93	17.00	17.07	16.66	16.04	13.52	12.11	9.68		
		Three Zone	MTIU-09HWFN1-M M30F-27HFN1-M	65(18.3)	54(12.2)	TC	22.31	24.40	25.27	26.43	26.80	26.95	26.91	27.48	28.72	28.11	27.52	28.08	28.42	27.89	26.64	22.05	20.75	18.37
						SC	18.09	19.55	20.36	20.77	20.96	20.56	20.58	19.97	20.76	21.63	20.54	21.29	22.65	20.24	19.17	16.13	15.21	13.72
				70(21.1)	59(15)	TC	23.60	25.55	27.17	27.71	27.97	28.05	28.63	29.08	29.38	29.44	29.59	29.87	29.76	29.20	28.19	23.46	21.96	19.54
						SC	19.14	20.80	21.55	22.09	22.18	21.55	21.48	21.59	22.20	22.65	21.74	22.65	23.97	21.53	20.29	17.16	16.09	14.60
75(23.9)	63(17.2)			TC	25.37	27.33	28.69	28.77	29.29	30.00	30.53	30.67	30.94	31.51	31.73	31.28	30.68	30.90	29.98	24.83	23.36	20.68		
				SC	20.25	21.77	23.17	23.16	23.15	23.29	22.85	22.85	23.48	23.72	23.37	24.10	25.10	22.55	21.47	18.25	17.03	15.53		
80(26.7)	67(19.4)			TC	26.43	28.32	30.02	30.13	30.98	31.42	32.23	32.78	33.03	32.98	32.87	32.75	32.64	32.36	31.40	26.58	24.26	21.65		
				SC	20.81	22.62	23.81	23.93	23.98	23.88	24.16	24.20	24.23	24.27	24.44	24.62	24.79	23.99	23.06	20.32	20.09	17.53		
Four Zone	MTIU-09HWFN1-M M40F-36HFN1-M			65(18.3)	54(12.2)	TC	29.51	32.21	31.92	32.81	34.00	34.45	35.13	35.57	35.78	36.82	36.87	36.95	37.49	35.19	33.32	27.70	25.85	23.64
						SC	22.02	23.07	25.08	25.07	24.78	25.37	25.68	24.85	26.87	27.61	27.13	27.54	28.45	27.09	26.83	23.71	23.28	22.24
				70(21.1)	59(15)	TC	31.21	33.72	34.32	34.39	35.49	37.24	37.38	37.59	37.85	38.55	38.57	38.64	39.26	36.85	35.25	29.47	27.35	25.14
						SC	23.30	24.54	26.54	26.67	26.22	26.59	26.81	26.87	28.74	28.91	28.71	29.30	30.10	28.82	28.39	25.22	24.64	23.66
		75(23.9)	63(17.2)	TC	33.56	35.35	37.11	37.38	37.96	38.62	39.18	39.82	40.05	41.02	40.82	40.58	40.37	38.59	36.65	30.86	29.41	26.36		
				SC	24.79	26.39	28.23	28.52	27.89	28.14	28.52	28.76	30.13	30.18	31.03	31.34	31.52	30.49	30.04	26.83	26.07	25.17		
		80(26.7)	67(19.4)	TC	35.52	37.61	39.27	39.76	40.17	41.53	41.73	42.08	42.83	42.95	43.19	43.17	43.14	41.05	38.78	32.83	31.12	28.04		
				SC	25.95	28.38	29.60	29.77	30.16	30.10	29.86	30.76	31.54	32.45	32.33	32.47	32.73	31.93	30.97	28.70	27.74	26.63		
		Five Zone	MTIU-09HWFN1-M M50F-48HFN1-M	65(18.3)	54(12.2)	TC	37.63	41.01	42.00	42.58	43.17	44.18	44.28	46.22	46.31	46.69	47.12	48.34	48.61	46.57	44.61	35.94	32.95	29.32
						SC	29.90	32.14	33.98	34.99	33.82	34.08	35.18	34.52	35.63	34.94	36.12	37.28	39.40	37.96	36.50	30.84	29.22	25.41
				70(21.1)	59(15)	TC	39.20	42.50	43.61	43.83	45.66	47.31	47.61	48.40	49.17	50.48	50.39	50.62	51.71	48.76	46.72	38.48	34.21	30.71
						SC	32.15	34.38	36.15	37.42	35.98	36.06	37.42	36.96	37.90	37.40	38.63	40.30	41.92	40.17	38.83	33.02	31.28	27.47
75(23.9)	63(17.2)			TC	41.48	45.21	46.15	46.31	48.32	49.59	49.70	51.24	52.59	52.86	53.32	53.85	53.72	51.88	49.44	40.93	36.20	32.66		
				SC	33.67	36.96	37.89	39.06	38.89	38.57	39.19	39.53	39.69	40.22	40.24	41.76	43.53	42.06	40.03	35.32	33.28	29.07		
80(26.7)	67(19.4)			TC	44.60	47.39	49.89	50.34	51.68	52.76	53.15	54.51	55.65	56.23	56.43	57.29	56.82	54.32	51.39	42.86	38.93	34.24		
				SC	35.61	38.70	40.74	40.95	40.60	41.70	41.69	41.83	41.97	42.11	43.27	44.42	45.58	44.05	42.36	37.57	35.21	30.93		

Zone	Model	Heating		Outdoor conditions (DB)°F(°C)														
		Indoor Conditions °F(°C)		-22 (-30)	-13 (-25)	-5 (-20.6)	0 (-17.8)	5 (-15)	17 (-8.3)	19.4 (-7)	24.8 (-4)	32 (0)	35 (1.7)	39.2 (4)	44.6 (7)	47 (8.3)	53.6 (12)	57 (13.9)
		DB																
Two Zone	MTIU-09HWFN1-M M2OF-18HFN1-M	60(15.6)	TC	5.97	7.10	8.36	9.52	10.96	13.75	16.84	18.62	19.91	20.29	23.07	24.82	25.56	27.70	28.93
			Input	1.24	1.31	1.49	1.50	1.51	1.56	1.80	1.71	1.80	1.91	1.93	1.99	1.98	1.94	1.79
		65(18.3)	TC	5.63	6.74	7.98	9.30	10.62	13.05	16.32	17.58	19.41	19.88	22.55	24.06	24.73	26.58	27.60
			Input	1.29	1.36	1.55	1.56	1.57	1.61	1.85	1.81	1.89	1.96	2.00	2.07	2.06	2.02	1.86
		70(21.1)	TC	5.38	6.36	7.62	8.83	10.14	12.52	15.58	16.67	18.80	19.34	21.18	22.84	23.97	25.50	26.48
			Input	1.34	1.42	1.61	1.63	1.63	1.65	1.89	1.92	1.98	2.01	2.08	2.16	2.13	2.11	1.93
		75(23.9)	TC	5.19	5.97	7.34	8.54	9.48	11.82	15.03	15.74	18.13	18.16	20.54	22.26	23.32	24.59	25.52
			Input	1.37	1.50	1.65	1.67	1.72	1.73	1.94	2.01	2.03	2.12	2.12	2.19	2.17	2.16	1.98
Three Zone	MTIU-09HWFN1-M M3OF-27HFN1-M	60(15.6)	TC	13.07	15.14	16.93	18.16	20.38	23.19	23.14	23.79	24.02	25.59	31.29	34.82	38.60	41.23	43.66
			Input	2.82	2.97	2.89	2.86	2.92	2.73	2.76	2.59	2.66	2.44	2.87	3.08	3.37	3.14	2.96
		65(18.3)	TC	12.34	14.37	16.16	17.05	19.35	21.78	22.08	22.60	23.29	24.57	30.34	33.76	37.43	40.60	42.33
			Input	2.94	3.14	3.02	3.00	3.04	2.83	2.88	2.72	2.74	2.50	3.04	3.23	3.46	3.25	3.07
		70(21.1)	TC	11.84	13.94	15.26	16.52	18.82	20.45	21.08	21.69	22.36	23.83	28.65	32.22	36.29	39.37	40.62
			Input	3.06	3.27	3.13	3.12	3.16	2.91	2.95	2.88	2.87	2.57	3.16	3.37	3.59	3.39	3.18
		75(23.9)	TC	11.42	13.09	14.70	15.98	17.58	19.31	20.33	20.48	21.56	22.38	27.77	31.40	35.29	37.97	39.13
			Input	3.17	3.41	3.25	3.26	3.28	2.99	3.02	3.05	3.01	2.64	3.28	3.52	3.72	3.54	3.30
Four Zone	MTIU-09HWFN1-M M4OF-36HFN1-M	60(15.6)	TC	17.61	19.48	21.00	23.20	26.00	28.98	29.98	33.75	35.28	34.93	38.56	41.85	45.72	47.49	49.00
			Input	3.57	3.74	3.35	3.41	3.46	3.63	3.31	3.42	3.58	3.34	3.47	3.53	3.90	3.53	3.26
		65(18.3)	TC	16.90	18.59	20.15	22.14	24.94	28.07	29.16	31.70	33.49	33.87	36.99	39.94	43.86	45.32	47.01
			Input	3.76	3.92	3.50	3.62	3.62	3.84	3.45	3.59	3.67	3.46	3.57	3.62	4.00	3.57	3.34
		70(21.1)	TC	15.96	17.65	19.23	21.02	23.81	26.93	27.83	30.06	31.96	32.11	35.12	37.51	41.86	43.48	44.87
			Input	3.96	4.03	3.71	3.79	3.80	4.01	3.62	3.74	3.81	3.61	3.70	3.78	4.08	3.66	3.41
		75(23.9)	TC	14.99	16.66	18.26	19.85	22.60	25.70	26.42	28.35	30.34	30.29	33.16	35.04	39.74	41.50	42.59
			Input	4.18	4.14	3.93	3.98	3.99	4.18	3.80	3.90	3.95	3.76	3.84	3.94	4.15	3.76	3.47
Five Zone	MTIU-09HWFN1-M M5OF-48HFN1-M	60(15.6)	TC	21.23	23.54	27.12	29.68	33.08	38.52	40.00	41.71	41.64	44.07	52.88	58.46	59.33	64.02	65.38
			Input	4.59	4.58	4.83	4.34	4.14	4.43	4.28	4.28	4.28	4.06	4.55	4.95	4.78	4.44	4.22
		65(18.3)	TC	20.15	22.91	25.60	28.31	31.56	36.95	38.16	40.01	40.15	42.27	50.99	56.07	58.30	62.39	64.18
			Input	4.73	4.70	4.97	4.50	4.34	4.59	4.56	4.44	4.42	4.35	4.82	5.14	5.03	4.61	4.38
		70(21.1)	TC	19.23	21.64	24.43	26.88	30.12	35.45	36.42	37.94	38.89	41.11	47.89	53.23	56.53	59.86	61.58
			Input	4.86	4.95	5.10	4.61	4.60	4.81	4.68	4.65	4.54	4.59	4.92	5.22	5.12	4.73	4.50
		75(23.9)	TC	18.06	20.43	23.19	25.11	28.44	33.11	34.57	35.86	37.51	39.28	46.19	51.34	54.52	58.64	59.39
			Input	5.04	5.09	5.38	4.73	4.71	5.10	4.88	4.83	4.71	4.71	5.19	5.44	5.26	4.85	4.67

## 13. Noise Criterion Curves

### 13.1 Indoor Unit

#### A6 Duct type

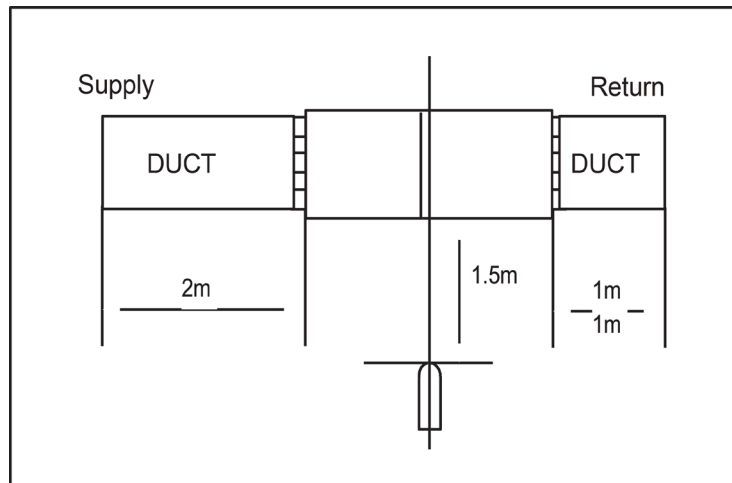

#### Notes:

- Sound measured at 1.5m away from the center of the unit.
- Data is valid at free field condition
- Data is valid at nominal operation condition
- Reference acoustic pressure  $OdB = 20\mu Pa$
- Sound level will vary depending on a range of factors such as the construction -(acoustic absorption coefficient) of particular room in which the equipment is installed.
- The operating conditions are assumed to be standard.

MTIU-09HWFN1-M

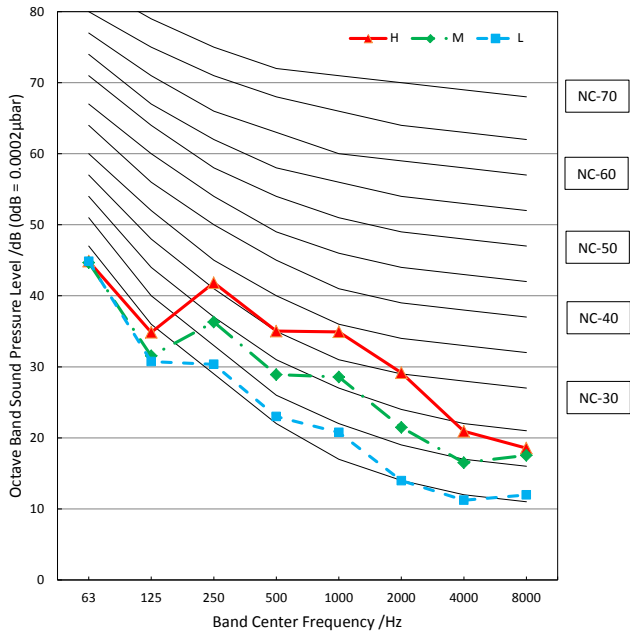

MTIU-12HWFN1-M

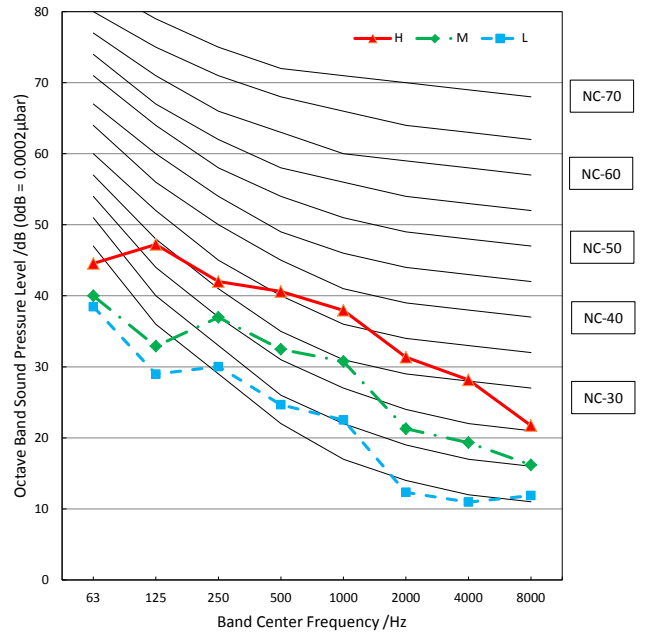

MTIU-18HWFN1-M

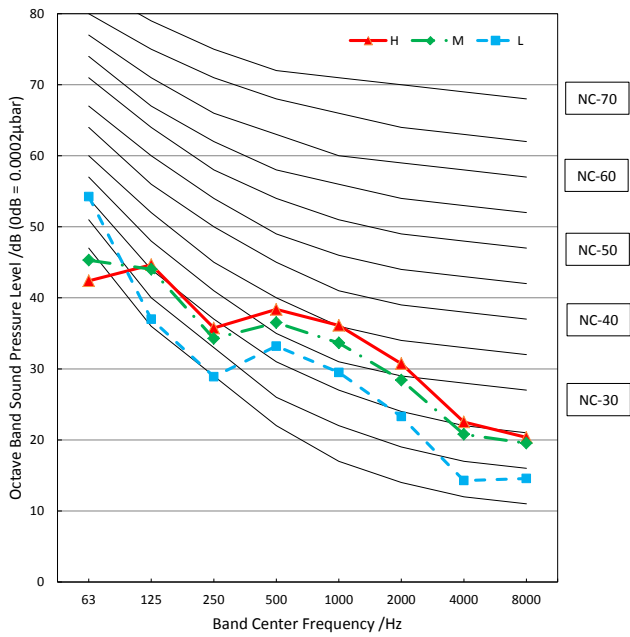

MTIU-24HWFN1-M

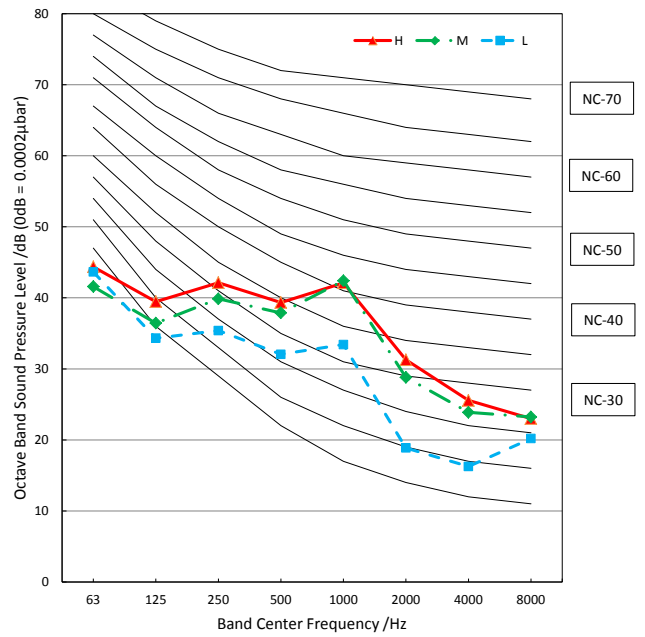

## Cassette type

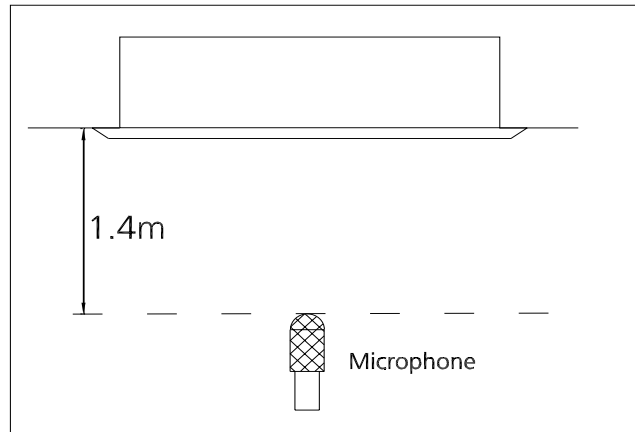

### Notes:

- Sound measured at 1.4m away from the noisiest location of the unit.
- Data is valid at free field condition
- Data is valid at nominal operation condition
- Reference acoustic pressure  $OdB = 20\mu Pa$
- Sound level will vary depending on a range of factors such as the construction -(acoustic absorption coefficient) of particular room in which the equipment is installed.
- The operating conditions are assumed to be standard.

MCA3U-09HRFN1-M(C)

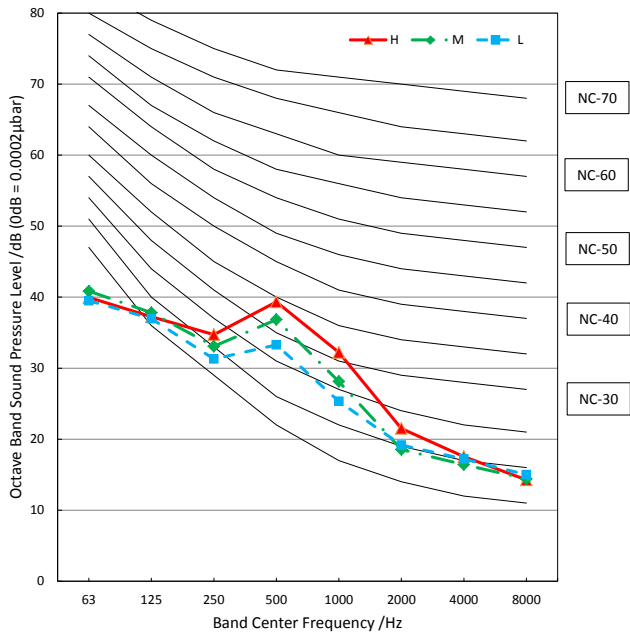

MCA3U-12HRFN1-M(C)

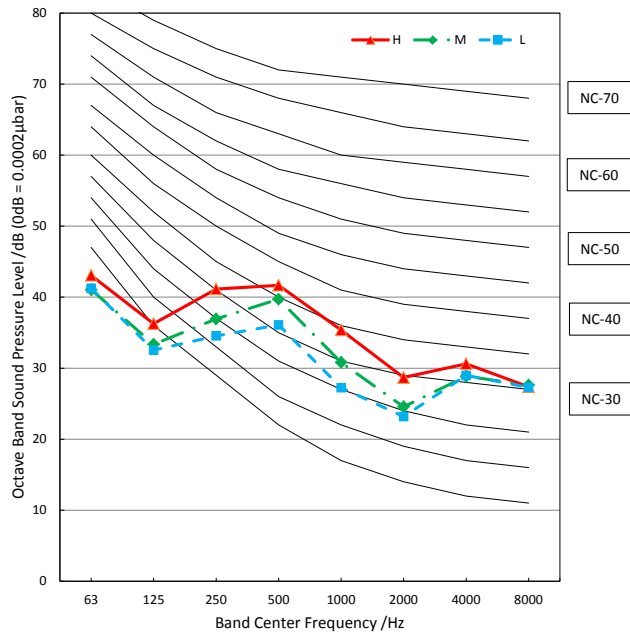

MCA3U-18HRFN1-M(C)

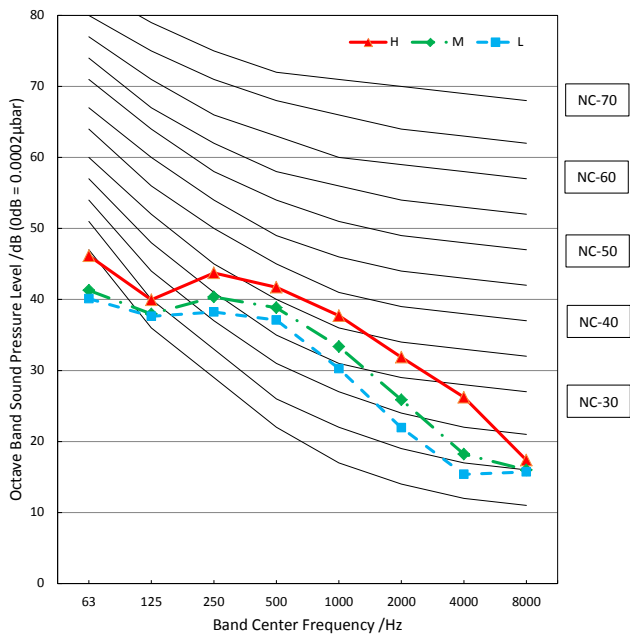

MCDU-24HRFN1-M(C)

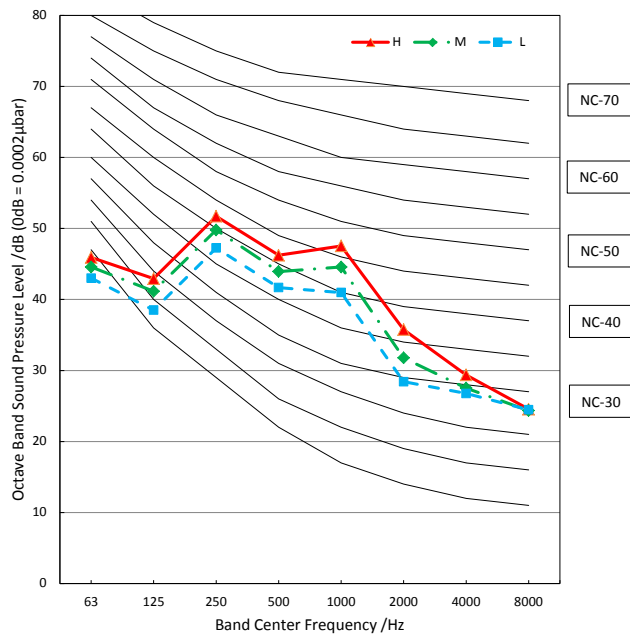

Floor ceiling type



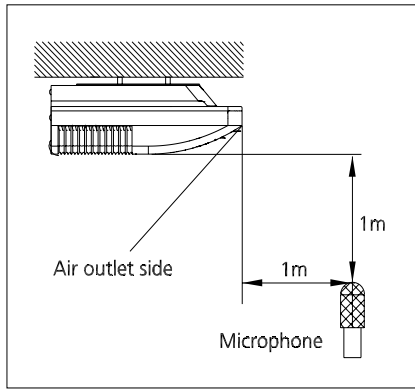

Ceiling

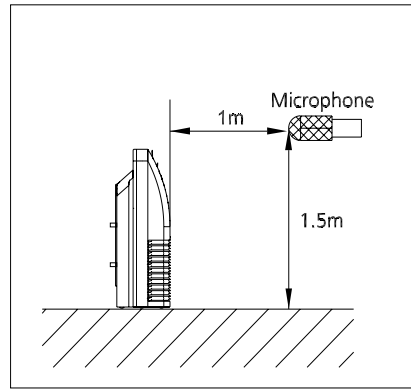

Floor

Notes:

- Sound measured at 1.5m away from the center of the unit.
- Data is valid at free field condition
- Data is valid at nominal operation condition
- Reference acoustic pressure  $O_{dB} = 20\mu Pa$
- Sound level will vary depending on a range of factors such as the construction -(acoustic absorption coefficient) of particular room in which the equipment is installed.
- The operating conditions are assumed to be standard.

MUEU-18HRFN1-M(C)

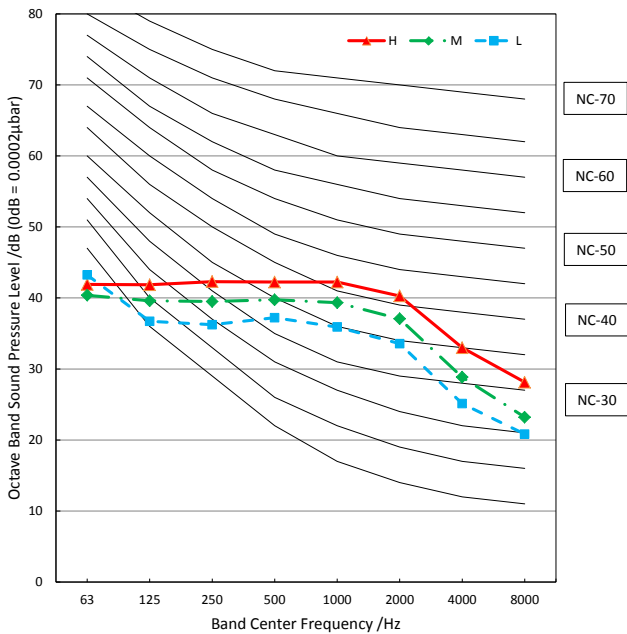

MUEU-24HRFN1-M(C)

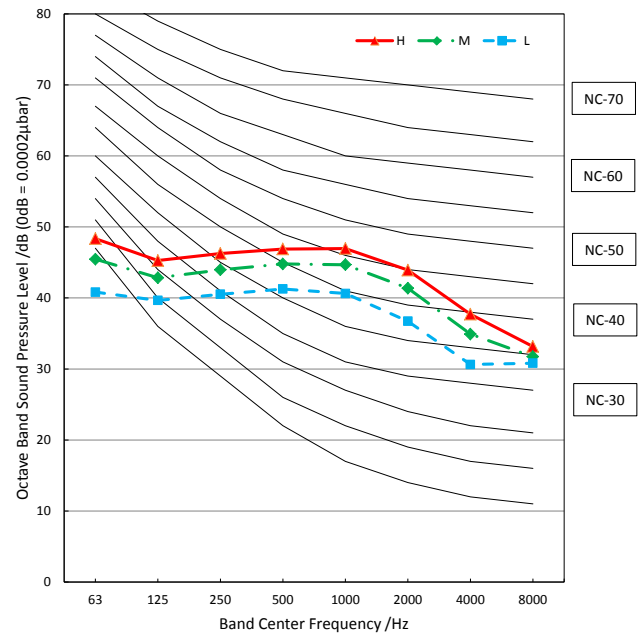

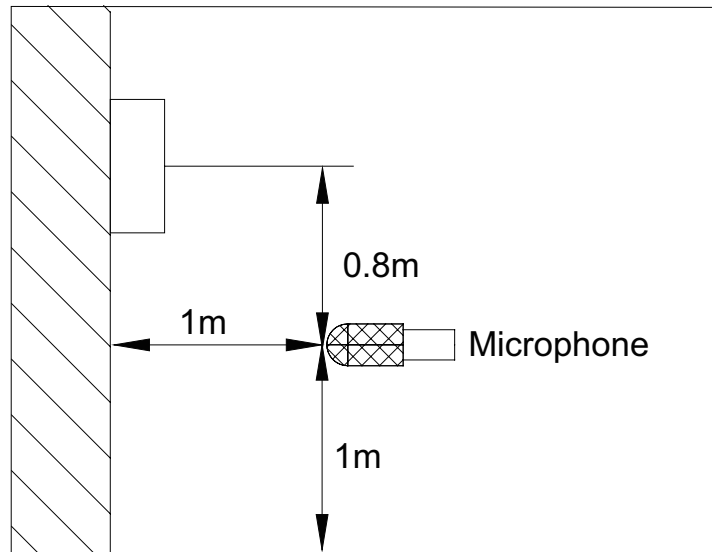
**Wall mounted type**

## Notes:

- Sound measured at 1.0m away from the center of the unit.
- Data is valid at free field condition
- Data is valid at nominal operation condition
- Reference acoustic pressure  $OdB = 20\mu Pa$
- Sound level will vary depending on a range of factors such as the construction -(acoustic absorption coefficient) of particular room in which the equipment is installed.
- The operating conditions are assumed to be standard.

MSABB-09HRFN1-MTOW

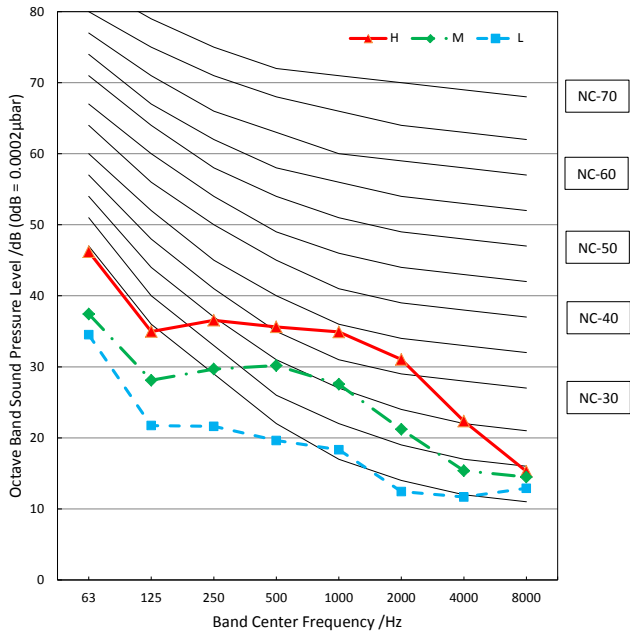

MSABB-12HRFN1-MTOW

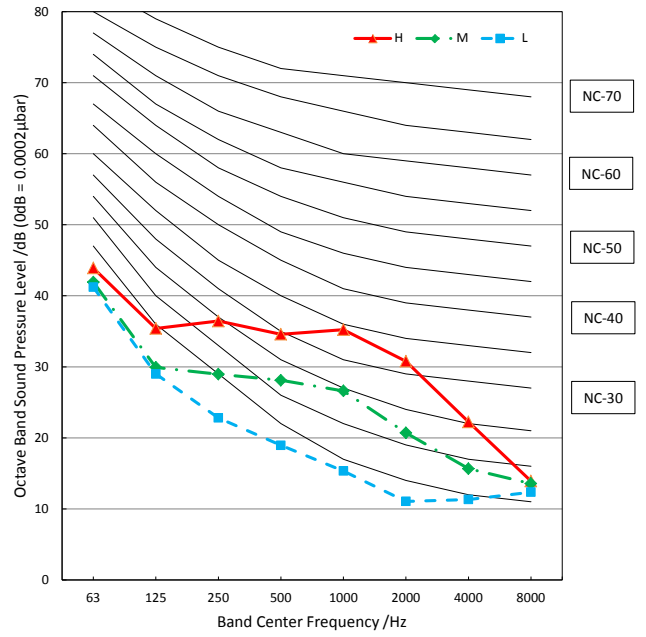

MSABE-18HRFN1-MTOW

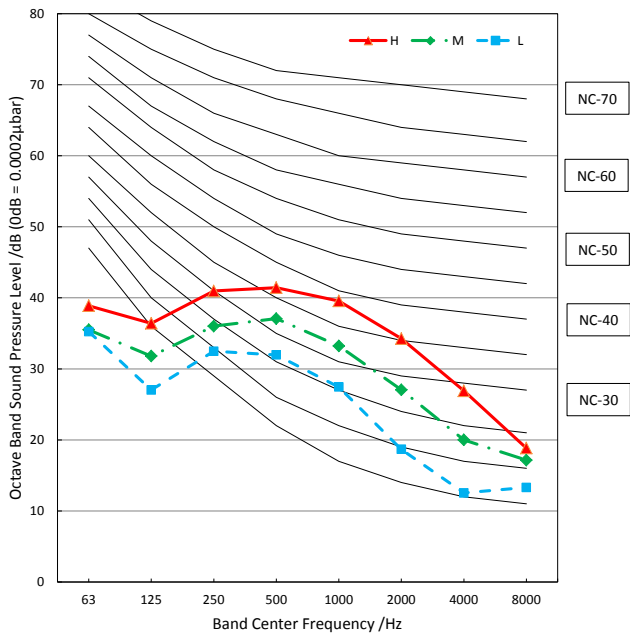

MSABE-24HRFN1-MTOW

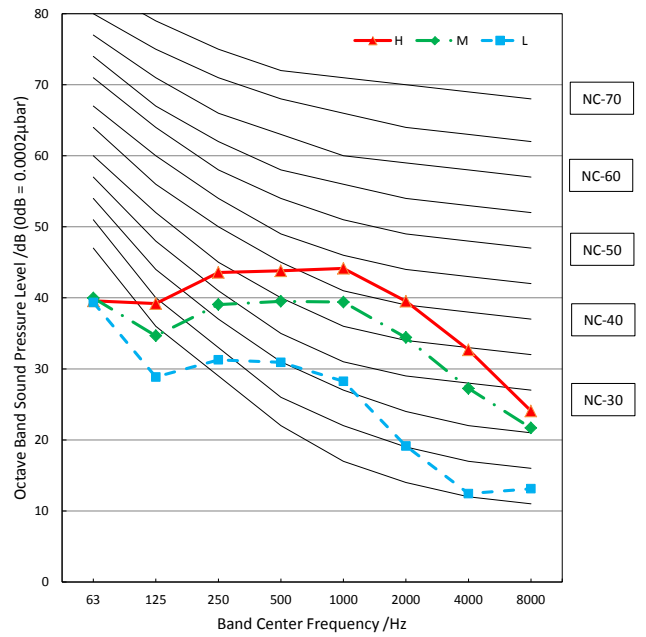

## 13.2 Outdoor Unit

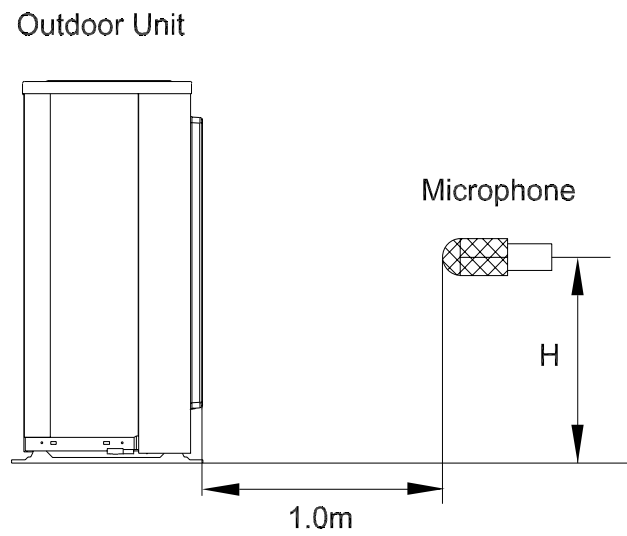

Note:  $H = 0.5 \times$  height of outdoor unit

### Notes:

- Sound measured at 1.0m away from the center of the unit.
- Data is valid at free field condition
- Data is valid at nominal operation condition
- Reference acoustic pressure  $OdB=20\mu Pa$
- Sound level will vary depending on arrangement of factors such as the construction (acoustic absorption coefficient) of particular room in which the equipment is installed.
- The operating conditions are assumed to be standard.

M2OF-18HFN1-M

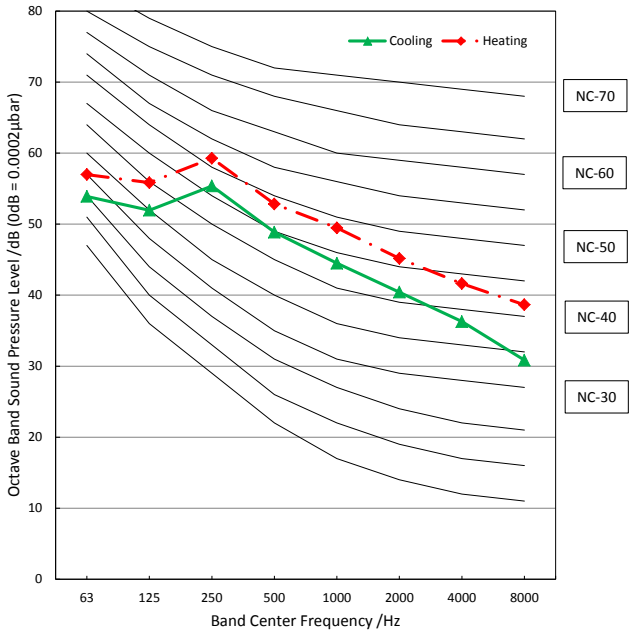

M3OF-27HFN1-M

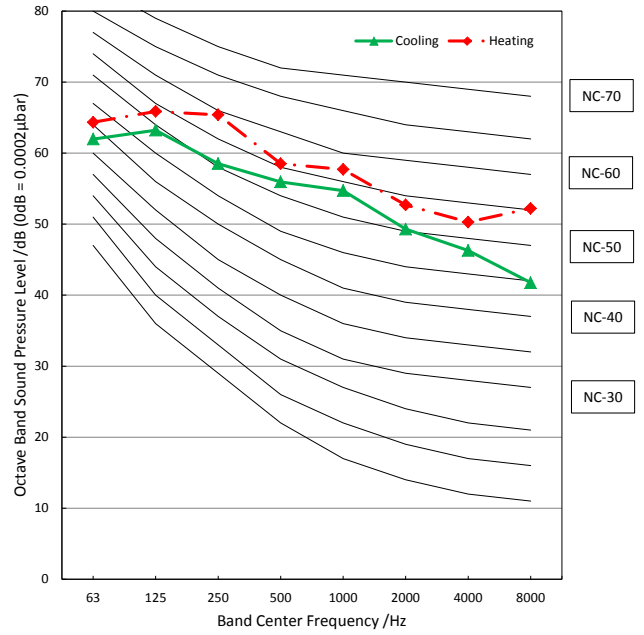

M4OF-36HFN1-M

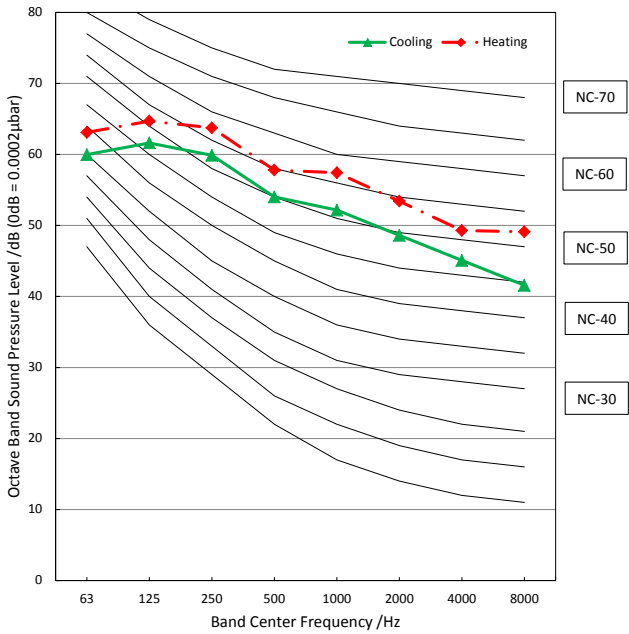

M5OF-48HFN1-M

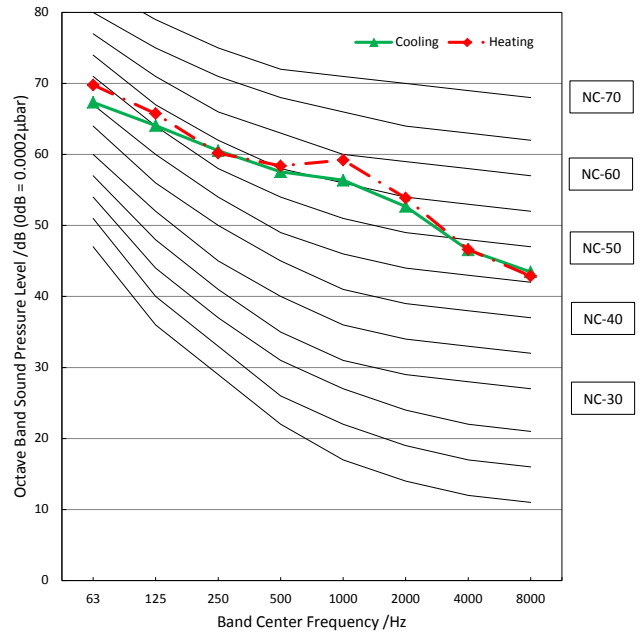

## 14. Electrical Characteristics

Model	Indoor Unit				Power Supply			IFM		
	Phase	Hz	Voltage	Voltage Range	MCA	MOP	MFA	kW	FLA	
MTIU-09HWFN1-M	1	60	208	Min:187 Max:229	/	/	/	0.13	1.11	
MTIU-12HWFN1-M					/	/	/	0.13	1.11	
MTIU-18HWFN1-M					/	/	/	0.2	1.65	
MTIU-24HWFN1-M					/	/	/	0.2	1.65	
MCA3U-09HRFN1-M(C)					/	/	/	0.046	0.465	
MCA3U-12HRFN1-M(C)					/	/	/	0.046	0.465	
MCA3U-18HRFN1-M(C)			/	/	/	0.046	0.465			
MCDU-24HRFN1-M(C)			230	60	Min:207 Max:253	/	/	/	0.042	0.332
MUEU-18HRFN1-M(C)						/	/	/	0.13	1.11
MUEU-24HRFN1-M(C)						/	/	/	0.13	1.11
MSABB-09HRFN1-MTOW						/	/	/	0.07	0.24
MSABB-12HRFN1-MTOW						/	/	/	0.07	0.24
MSABE-18HRFN1-MTOW						/	/	/	0.125	0.4
MSABE-24HRFN1-MTOW						/	/	/	0.125	0.4

Model	Outdoor Unit				Power Supply			Compressor		OFM		
	Phase	Hz	Voltage	Voltage Range	MCA	MOP	MFA	MSC	RLA	Qty	kW	FLA
M2OF-18HFN1-M	1	60	208	Min:187	15	25	20	/	8.1	1	0.05	0.55
M3OF-27HFN1-M				Max:229	25	50	40	/	6.95	1	0.12	1.39
M4OF-36HFN1-M			230	Min:207	30	70	55	/	5.1	1	0.12	1.39
M5OF-48HFN1-M				Max:253	30	70	55	/	6.85	2	0.085	1.18

Notes:

MCA: Minimum Circuit Amperes (A)

MOP: Maximum rating over current protective device

MFA: Maximum Fuse Amperes (A)

MSC: Maximum Starting Current

RLA: Rated Load Amperes (A)

IFM: Indoor Fan Motor

OFM: Outdoor Fan Motor

FLA: Full Load Amperes (A)

# 15. Static Pressure

9K

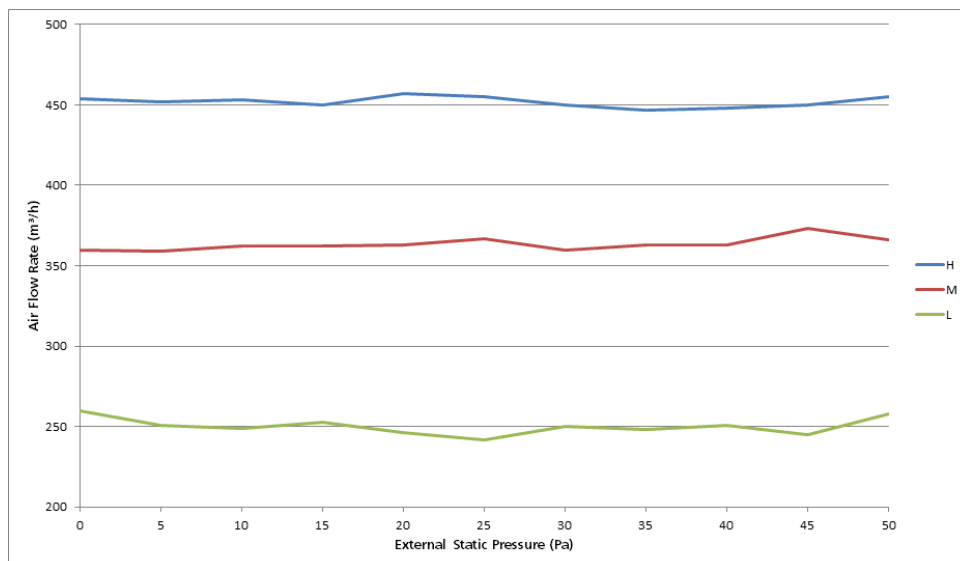
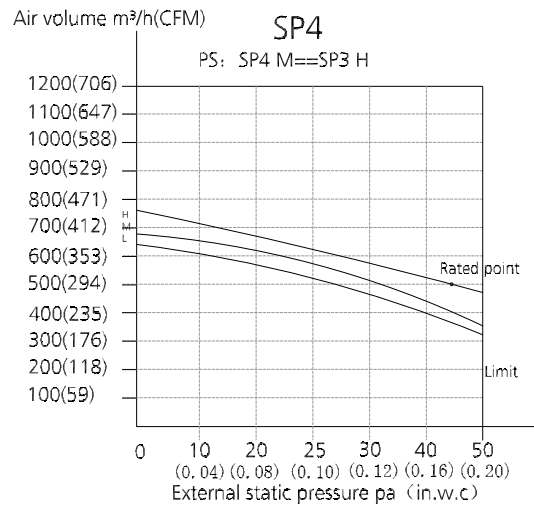
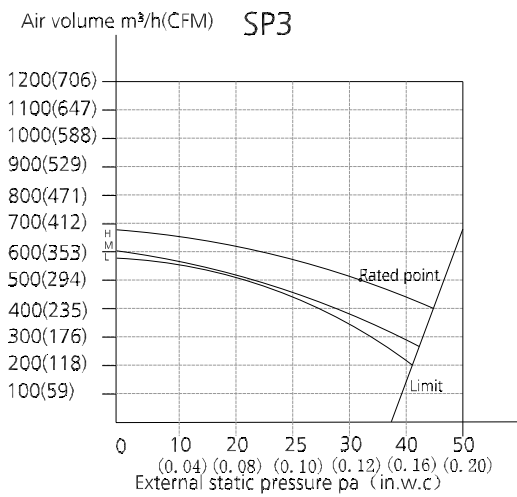
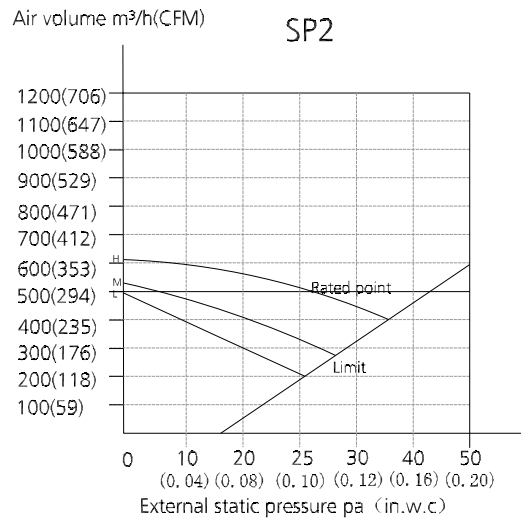
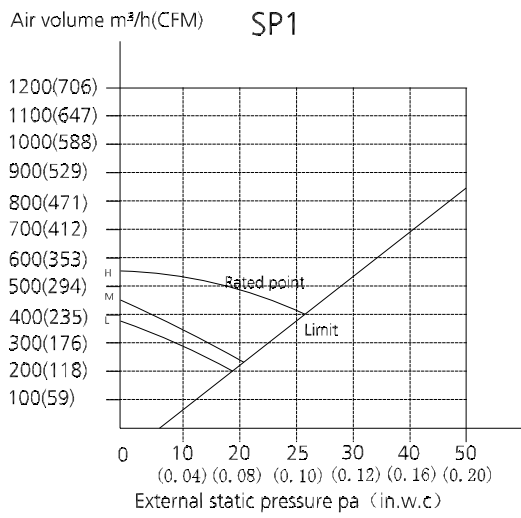

12K

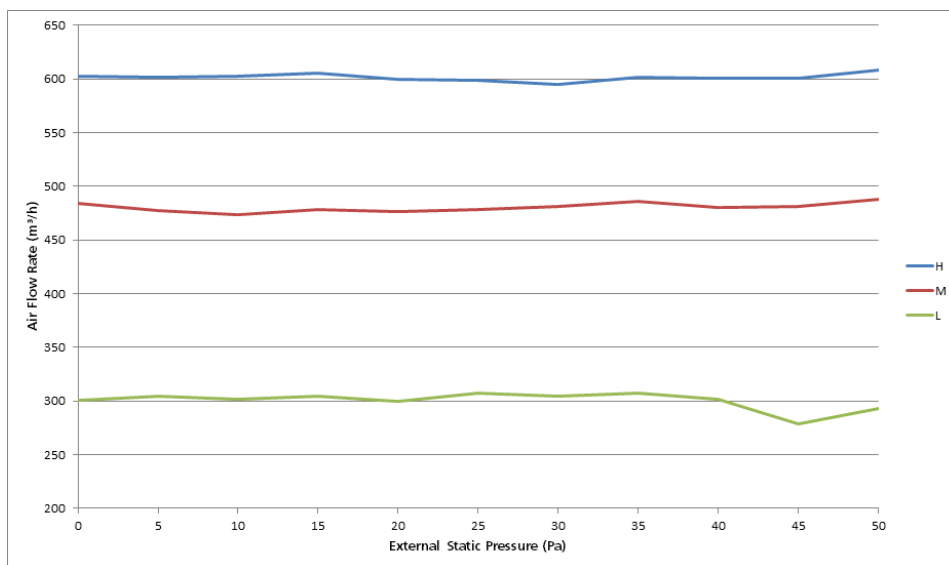
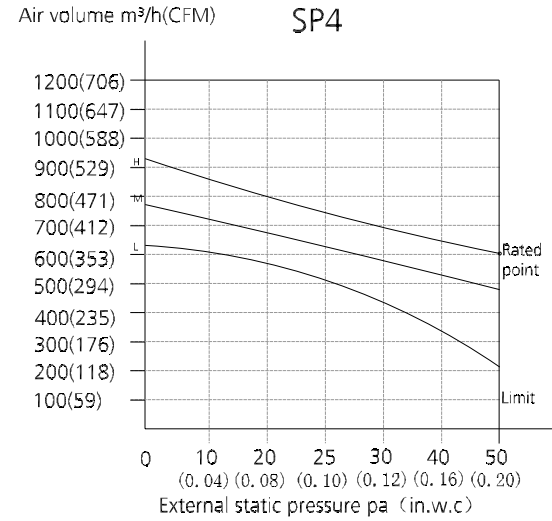
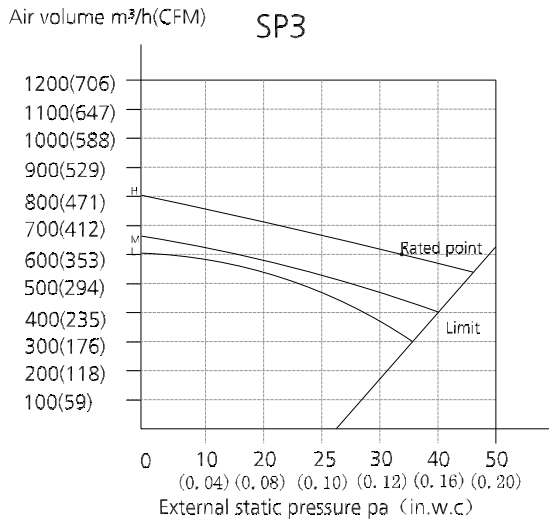
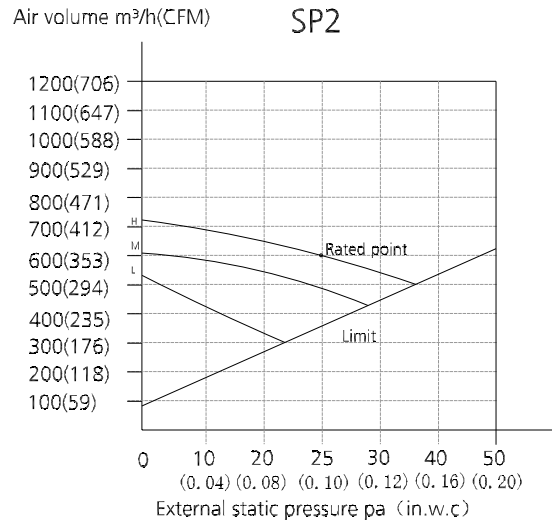
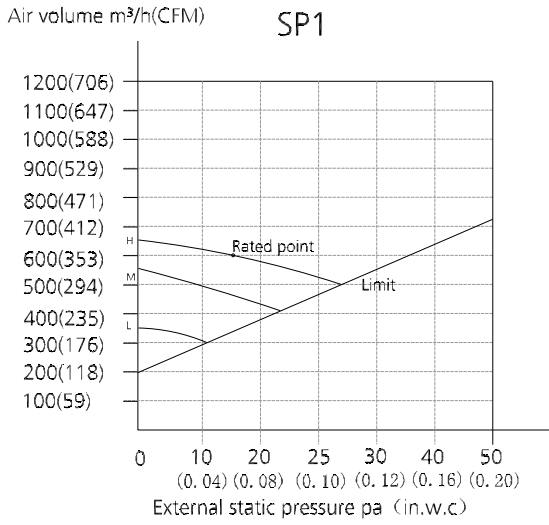



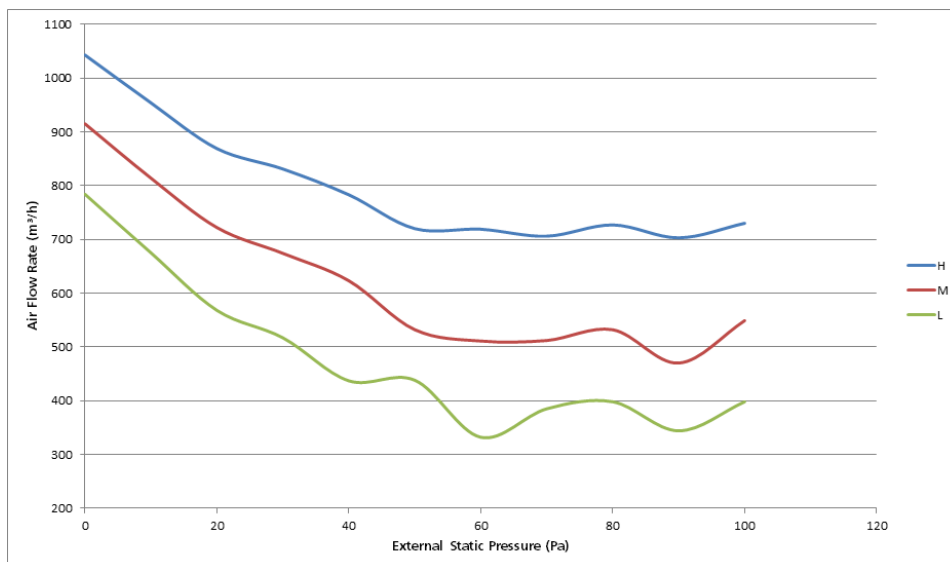
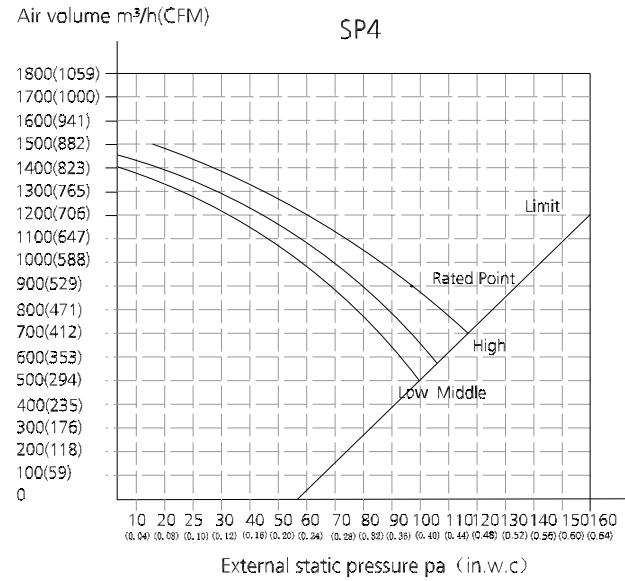
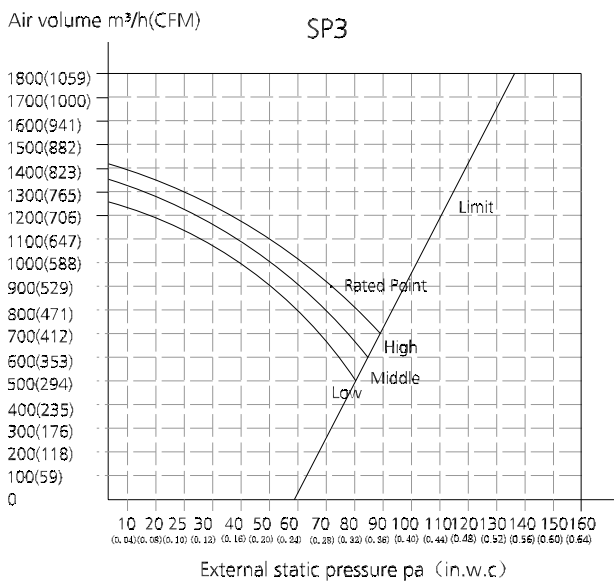
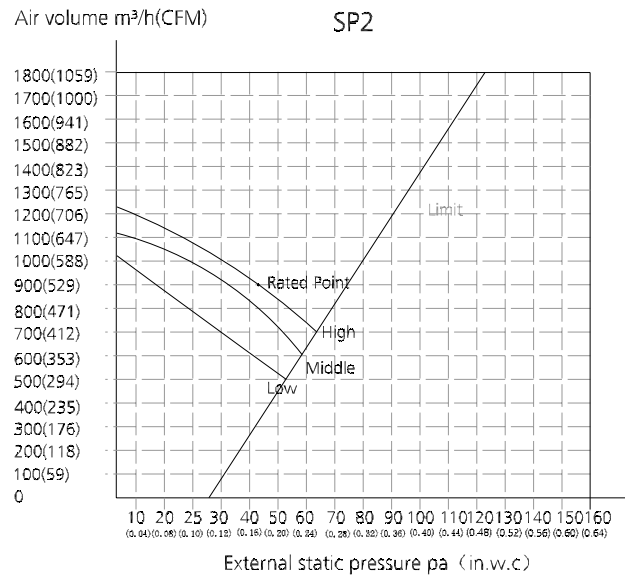
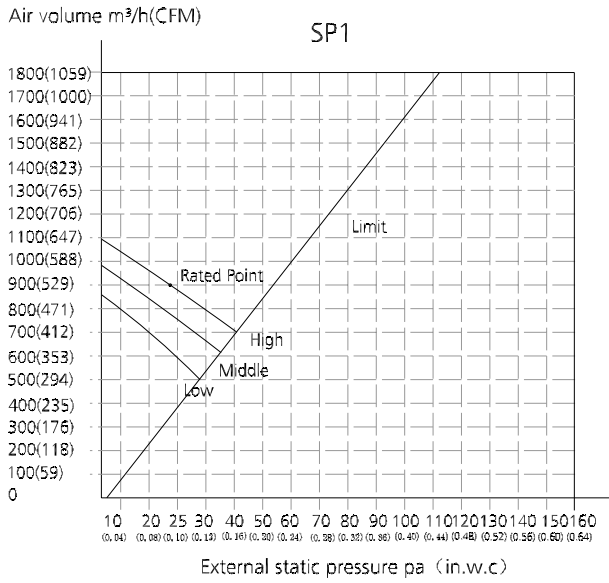

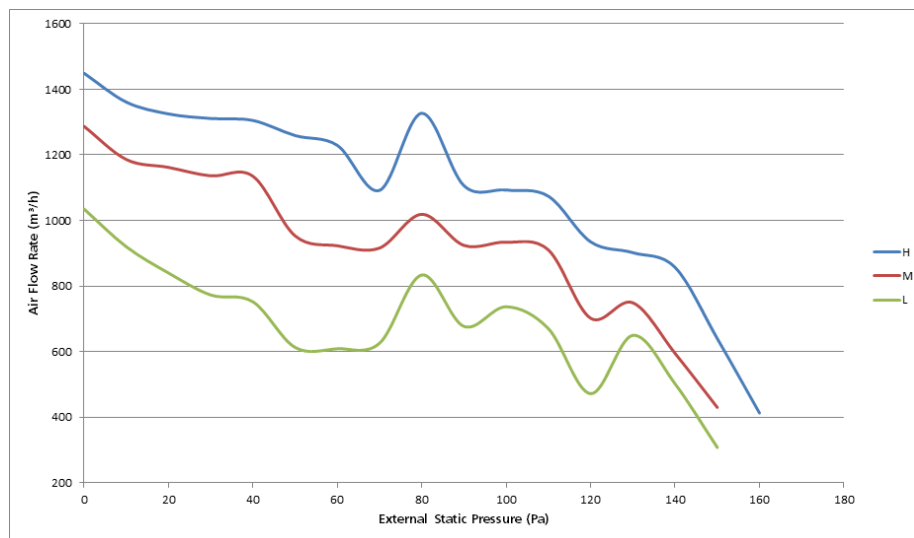
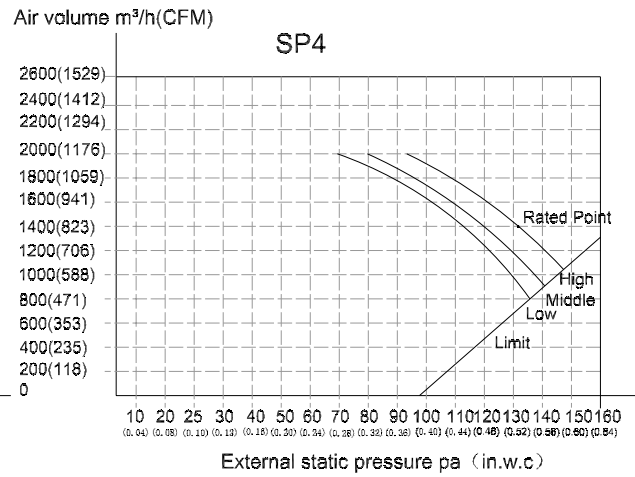
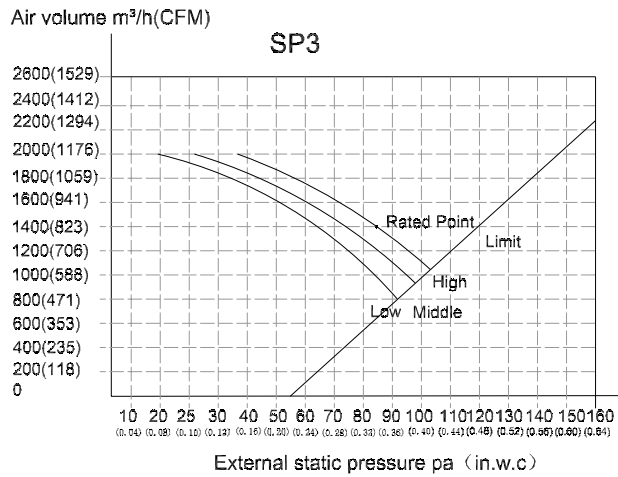
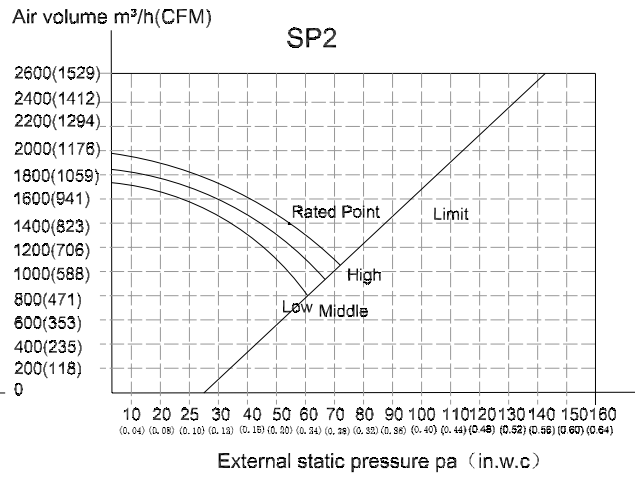
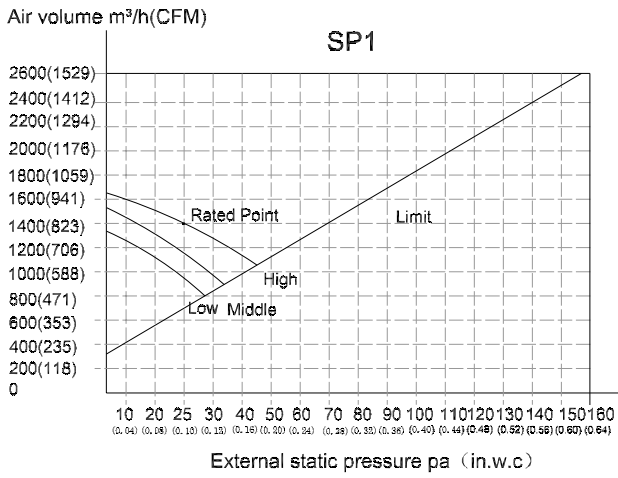

---

# Product Features

## Contents

<b>1.</b>	<b>Display Function .....</b>	<b>100</b>
<b>2.</b>	<b>Operation Modes and Functions .....</b>	<b>102</b>
2.1	Abbreviations .....	102
2.2	Safety Features .....	102
2.3	Fan.....	103
2.4	Cooling Mode .....	103
2.5	Heating Mode (Heat pump models).....	103
2.6	Auto Mode.....	103
2.7	Drying Mode .....	103
2.8	Timer Function .....	104
2.9	Sleep Function.....	104
2.10	Forced Operation Function .....	104
2.11	Auto-Restart.....	104
2.12	Follow Me .....	104
2.13	Drain Pump Control.....	104
2.14	Mode Conflict .....	105
<b>3.</b>	<b>Remote Controller Functions .....</b>	<b>105</b>
3.1	Infrared Wireless Remote Controller.....	105
3.2	LCD Wired Remote Controller .....	108
3.3	Centralized Controller .....	120
3.4	Using the wire controller to set external static pressure .....	121
3.5	Using the wire controller to set airflow rate .....	121

# 1. Display Function

Wall mounted type:

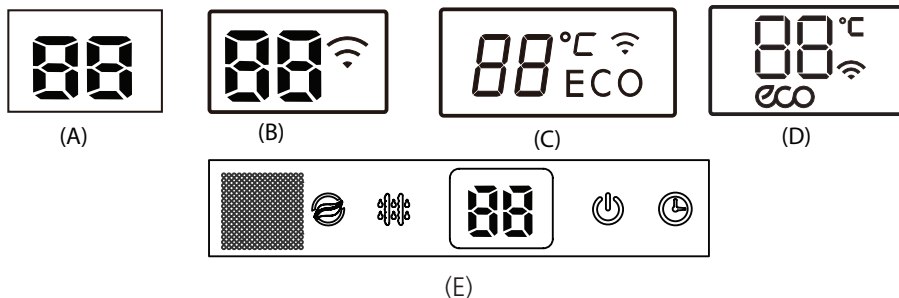

Product Features

Display	Function	
	Fresh(available on select units only)	
	Defrost	
	When the unit is on	
	When TIMER is on	
ECO	ECO function (available on select units only)	
°C	Lights up in different colour according to the operation mode(some units): Under COOL and DRY mode, it displays as cool colour.Under HEAT mode, it displays as warm colour.	
	when Wireless Control feature is activated(some units)	
	Temperature value	Temperature
		Activation of Timer ON, Fresh, Swing, Turbo, or Silent
		Cancellation of Timer OFF, Fresh, Swing, Turbo, or Silent
		Defrost
		Warming in heating mode
		Self-clean (available on select units only)
		Heating in room temperature under 8°C

**Note: Please select the display function according to your purchase product.**

A6 Duct type:

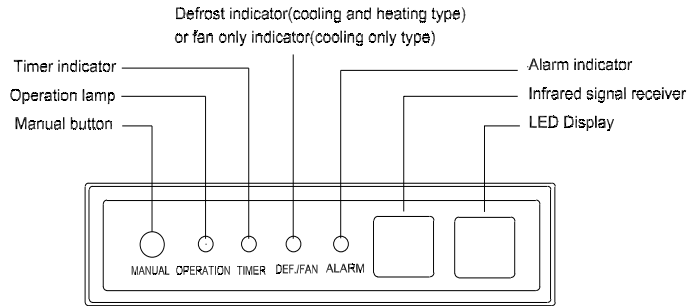

Compact Cassette type:

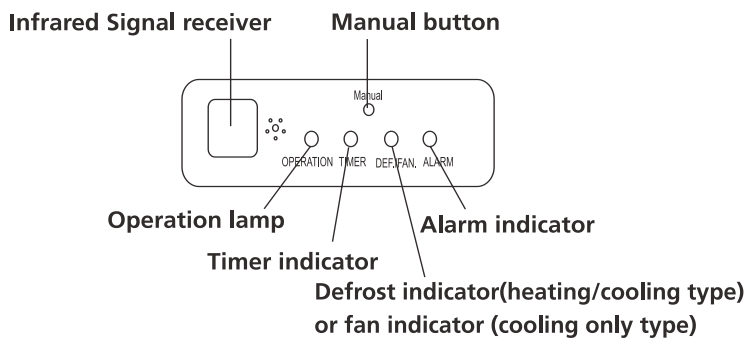

Super-slim Cassette Type

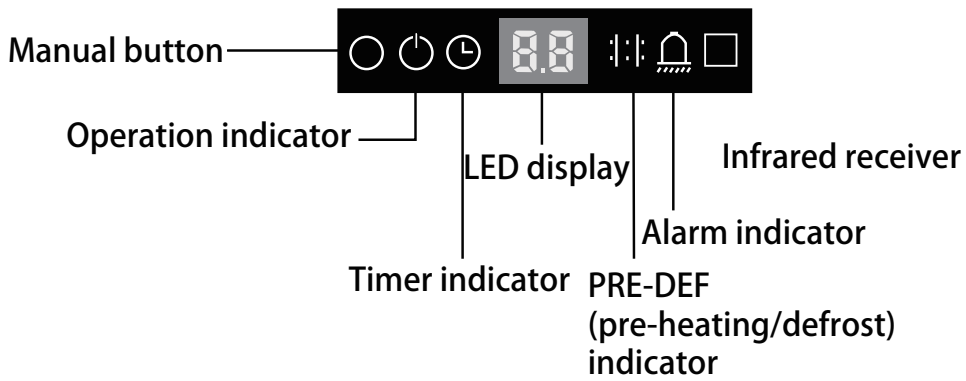

Floor Ceiling Type

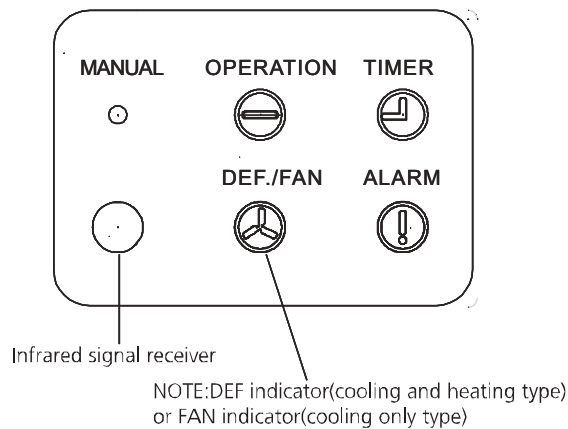

## 2. Operation Modes and Functions

### 2.1 Abbreviation

Unit element abbreviations

Abbreviation	Element
T1	Indoor room temperature
T2	Coil temperature of evaporator middle
T2B	Coil temperature of evaporator outlet(It is located in outdoor unit)
T3	Coil temperature of condenser
T4	Outdoor ambient temperature
T5	Compressor discharge temperature
TS	Setting temperature

### 2.2 Safety Features

#### Open Circuit/Disconnection Sensor Protection

##### Automatic shutoff based on fan speed

For A6 Duct type,

If a fault occurs on the air volume regulator or the regulator enters protection mode, it sends the error message CF and an instruction to reduce fan speed to the master. The message and the instruction can be inquired with the remote controller or the wired controller. (Fault and protection information are displayed for one minute). After a fault occurs, the master unit shows the error code E3 and the fault count for one minute.

If the fault occurs three times, then the fan is unable to resolve the problem independently. External shutdown by a remote controller, wired controller, or central controller must be used to clear the fan fault and fault count. The fan runs normally for 5 minutes while clearing fault count.

For other types,

If the indoor fan speed registers below 300RPM for an extended period of time, it shuts off and restarts in 30 seconds. If this happens 3 times, the unit ceases operation and the corresponding error code is displayed on the indoor unit.

If outdoor fan speed registers below 100RPM or higher than 2400RPM for an extended period of time, the unit ceases operation and the corresponding error code is displayed on the indoor unit and outdoor unit.

#### Indoor fan delayed operation

- When the unit starts, the louver is automatically

activated and the indoor fan will operate after a period of 7 seconds.

- If the unit is in heating mode, the indoor fan is regulated by the anti-cold wind function.

#### Zero crossing detection error protection(For Wall mounted type)

If AC can not detect zero crossing signal for 4 minutes or the zero crossing signal time interval is not correct, the unit will stop and the LED will display the failure. The correct zero crossing signal time interval should be between 6-13ms.

#### Compressor three-minute delay at restart

Compressor functions are delayed for up to one minute upon the first startup of the unit, and are delayed for up to three minutes upon subsequent unit restarts.

#### Inverter module protection

The inverter module has an automatic shutoff mechanism based on the unit's current, voltage, and temperature. If automatic shutoff is initiated, the corresponding error code is displayed on the indoor unit and the unit ceases operation.

#### Automatic shutoff based on discharge temperature

If the compressor discharge temperature exceeds a certain level for a period of time, the compressor ceases operation.

#### Oil return

Running rules:

1. If the compressor frequency keeps lower than setting frequency for setting time, the AC will rise the frequency to setting frequency for setting time and then resume to former frequency.
2. The EXV will keep 300p while the indoor units will keep the current running mode.

If the outdoor ambient is higher than setting frequency during the oil return, the AC quit oil return.

## 2.3 Fan Mode

When fan mode is activated:

- The outdoor fan and compressor cease operation.
- Temperature control is disabled and no temperature setting is displayed.
- The indoor fan speed can be set to high, medium, low, or auto.
- The louver operations are identical to those in cooling mode.

## 2.4 Cooling Mode

### 2.4.1 Indoor Fan Control

- In cooling mode, the indoor fan operates continuously. The fan speed can be set to high, medium, low or auto.
- The auto fan acts according to the value of T1-Ts.

### 2.4.2 Outdoor Fan Control

- The outdoor fan is controlled by T4.

### 2.4.3 Evaporator Temperature Protection

When  $T_2 < 4^\circ\text{C}$  for 250 seconds or  $T_2 < 0^\circ\text{C}$ , the compressor and outdoor fan cease operation and resume to normal when  $T_2 > 8^\circ\text{C}$  and the time of protection is no less than 3 minutes.

### 2.4.4 Condenser Temperature Protection

When condenser temperature is more than setting value, the compressor ceases operations.

## 2.5 Heating Mode(Heat pump models)

### 2.5.1 Indoor Fan Control:

- When the compressor is on, the fan speed can be set to high, medium, low, or auto. And the anti-cold wind function has the priority.
- The auto fan acts according to the value of T1-Ts.

### 2.5.2 Outdoor Fan Control:

- The outdoor fan is controlled by T4.

### 2.5.3 Defrosting mode

- The unit enters defrosting mode according to the value of temperature of T3 and the value range of temperature change of T3 and also the compressor running time.
- If any one of the following items is satisfied, the defrosting will finish and the machine will turn to normal heating mode.
  - T3 rises to be higher than TCDE1°C.
  - T3 keeps to be higher than TCDE2°C for 80

seconds.

- The machine has run for 10 minutes in defrosting mode.

### 2.5.4 Evaporator Temperature Protection

When the evaporator temperature exceeds a preset protection value, the compressor and outdoor fan cease operations, the outdoor fan motor ceases operation 30 seconds later.

### 2.5.5 Prevent Over-Heating

In heating mode, when the indoor unit has no capacity requirement due to indoor room temperature increased, the Indoor fan will run in super breeze. (Anti-cold wind function has the priority)

## 2.6 Auto Mode

- This mode can be selected with the remote controller and the temperature setting can be adjusted between  $17^\circ\text{C} \sim 30^\circ\text{C}$
- In auto mode, the machine selects cooling, heating, or fan-only mode on the basis of  $\Delta T$  ( $\Delta T = T_1 - T_s$ ).

$\Delta T$	Running mode
$\Delta T > 2^\circ\text{C}$	Cooling
$-2^\circ\text{C} \leq \Delta T \leq 2^\circ\text{C}$	Fan-only
$\Delta T < -2^\circ\text{C}$	Heating*

Heating\*: In auto mode, cooling only models run the fan.

- Indoor fans run at the auto fan speed of the relevant mode.
- The louver operates the same as in relevant mode.
- If the machine switches mode between heating and cooling, the compressor pauses for a certain period of time intermittently and then selects a mode based on T1-Ts.
- If the setting temperature is modified, the machine selects a new running function.

## 2.7 Drying Mode

- Indoor fan speed is fixed at low and cannot be changed.
- Low indoor room temperature protection
- In drying mode, if room temperature is lower than  $10^\circ\text{C}$ , the indoor fan will stop and not resume until room temperature exceeds  $12^\circ\text{C}$ .
- All protections are activated and operate the same as they do in cooling mode.
- The louver operates the same as in cooling mode.

## 2.8 Timer Function

- The timing range is 24 hours.
- Timer On. The machine turns on automatically at the preset time.
- Timer Off. The machine turns off automatically at the preset time.
- Timer On/Off. The machine turns on automatically at the preset On Time, and then turns off automatically at the preset Off Time.
- Timer Off/On. The machine turns on automatically at the preset Off Time and then turns off automatically at the preset On Time.
- The timer does not change the unit operation mode. If the unit is off now, it does not start up immediately after the "timer off" function is set. When the setting time is reached, the timer LED switches off and the unit running mode remains unchanged.
- The timer uses relative time, not clock time

## 2.9 Sleep Function

- The sleep function is available in cooling, heating, or auto mode.
- The operational process for sleep mode is as follows:
- When cooling, the temperature rises 1°C (to not higher than 30°C) every hour. After 2 hours, the temperature stops rising and the indoor fan is fixed to auto speed.
- When heating, the temperature decreases 1°C (to not lower than 17°C) every hour. After 2 hours, the temperature stops decreasing and the indoor fan is fixed at auto speed. Anti-cold wind function takes priority.

## 2.10 Forced operation function

- Forced cooling mode:

The compressor and outdoor fan continue to run and the indoor fan runs at rated speed. After running for 30 minutes, the AC will switch to auto mode with a preset temperature of 24°C

- Forced auto mode:

Forced auto mode operates the same as normal auto mode with a preset temperature of 24°C.

- When any one of indoor units runs in forced cooling, it is designated as the master forced cooling unit. Other indoor units act as the slave forced cooling units. The slave forced cooling units cannot exit forced cooling mode until the master forced cooling unit does so. They then switch to

cooling mode in low fan with the temperature set at 24°C.

- Forced defrosting mode:
  - In the forced cooling mode (single heat engine for forced auto mode), press and hold the forced key for 5 seconds after release, immediately enter the forced frosting mode.
  - When any one of indoor units runs in forced defrosting mode, the indoor fan is off and other indoor fans are off. The outdoor unit operates forced defrosting.

## 2.11 Auto-Restart

- The indoor unit has an auto-restart module that allows the unit to restart automatically. The module automatically stores the current settings (not including sleep mode) and, in the case of a sudden power failure, will restore those setting automatically within 3 minutes after power returns.
- If the unit was in forced cooling mode, it will run in this mode for 30 minutes and turn to auto mode with temperature set to 24°C.
- If there is a power failure while the unit is running, the compressor starts 3 minutes after the unit restarts. If the unit was already off before the power failure, the compressor starts 1 minute after the unit restarts.

## 2.12 2.12 Follow Me (Optional)

- If you press "Follow Me" on the remote, the indoor unit will beep. This indicates the follow me function is active.
- Once active, the remote control will send a signal every 3 minutes, with no beeps. The unit automatically sets the temperature according to the measurements from the remote control.
- The unit will only change modes if the information from the remote control makes it necessary, not from the unit's temperature setting.

## 2.13 Drain Pump Control (Optional)

- Use the water-level switch to control drain pump.
- The system checks the water level every 5 seconds.
  - When the A/C operates in cooling (including auto cooling) or forced cooling mode, the pump begins running immediately and continuously until cooling stops.
  - If the water level increases up to the control point, the LED displays an alarm code and the drain pump opens and continually monitors the water level. If the water level falls and LED alarm code is no longer



displayed (drain pump close delay is 1 minute), the unit goes back into its last mode. Otherwise, the entire system (including the pump) stops and the LED displays an alarm again after 3 minutes.

## 2.14 Mode Conflict

- The indoor units can not work cooling mode and heating at same time.
- Heating mode has a priority.

(1) Definition

	Cooling mode	Heating Mode	Fan	Off
Cooling mode	No	Yes	No	No
Heating Mode	Yes	No	Yes	No
Fan	No	Yes	No	No
Off	No	No	No	No

No: No mode conflict;

Yes: Mode conflict

(2) Unit action

- In case of one Indoor unit working in cooling mode or fan mode, and another indoor unit is set to heating mode, the indoor unit working in cooling mode or fan mode will change to off. The outdoor unit will change to heating mode after compressor stop 3 minutes. .
- In case of one Indoor unit working in heating mode, and another indoor unit is set to cooling mode or fan mode, the indoor unit setting to cooling mode or fan mode will change to stand by. The outdoor unit will continue working in heating mode.
- If heating mode stops (not including the indoor unit in heating mode reaching the set temperature), 3 minutes after the outdoor unit restarts and works in cooling mode or fan-only mode.

## 3. Remote Controller Functions

### 3.1 Infrared Wireless Remote Controller

#### 3.1.1 RG05F2/BGEU1(Standard for cassette & Floor ceiling type)

#### Remote Controller Specifications

Model	RG05F2/BGEU1
Rated Voltage	3.0V (Dry batteries R03/LR03×2)
Reaching Distance	8m
Environment Temperature Range	-5℃ ~60℃ (23 F ~140 F)

#### Buttons and Functions

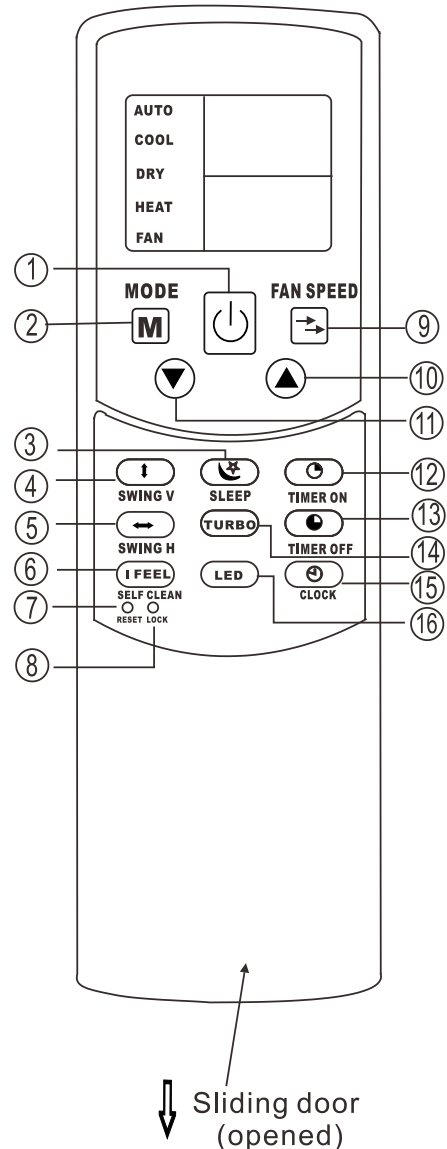

1. ON/OFF Button: For turning on or turning off the air conditioner.
2. MODE Button: Once pressing, running mode will be selected in the following sequence:

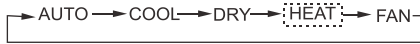

NOTE: No heating mode for cool only type unit.

3. SLEEP Button: Active/Disable sleep function. It can maintain the most comfortable temperature and save energy. This function is available on COOL, HEAT or AUTO mode only .

NOTE: While the unit is running under SLEEP mode, it would be cancelled if press MODE, FAN SPEED or ON/OFF button.

4. SWING V Button: Used to stop or start horizontal louvre movement or set the desired up/down air flow direction. The louvre changes 6 degree in angle for each press. If keep pushing more than 2 seconds, the louvre will swing up and down automatically.
5. SWING H Button: Used to stop or start vertical louvre movement and set the desired left/right air flow direction. The vertical louvre changes 6 degree in angle for each press.
6. I FEEL/ SELF CLEAN Button: Press this button less than 2 seconds will initiate I FEEL function. And if keep pressing this button more than 2 seconds, the SELF CLEAN function is initiated.

When the I FEEL function is activated, the remote display is actual temperature at its location. The remote control will send this signal to the air conditioner every 3 minutes interval until press the I FEEL button again.

The I FEEL function is not available under DRY and FAN mode.

Switch the operation mode or turn off the unit will cancel the I FEEL function automatically.

Under SELF CLEAN mode, the air conditioner will automatically clean and dry the evaporator and keep it as fresh for the next operation.

7. RESET Button(inner located): Once the recessed RESET button is pressed, all of the current settings will be cancelled and the controller will return to the initial settings.
8. LOCK Button(inner located): Press this recessed button to lock all current settings, and the remote controller will not accept any operation except that of the LOCK.  
Use the LOCK mode when you want to prevent settings from being changed accidentally.

Press the LOCK button again to cancel the LOCK function. A lock symbol will appear on the remote controller display when the lock function is activated.

9. FAN SPEED Button: Fan speed will be selected in following sequence once pressing this button:



10. UP Button: Push this button to increase setting temperature or to increase Hour during Clock time setting.
11. TEMP DOWN Button : Push this button to decrease setting temperature or to decrease Hour during Clock time setting.

NOTE: Press and hold UP and DOWN buttons together for 3 seconds will alternate the temperature display between the °C & °F scale.

12. TIME ON Button: For time ON setting. Press this button to activate the Auto-on time setting. Each press will increase the time setting in 30 minutes increments, up to 10 hours, then at 1 hour increments up to 24 hours. To cancel the Auto-on time setting, just press the button until the time setting is 0.0.

13. TIME OFF Button: For time OFF setting. Press this button to activate the Auto-off time setting. Each press will increase the time setting in 30 minutes increments, up to 10 hours, then at 1 hour increments up to 24 hours. To cancel the Auto-off time setting, just press the button until the time setting is 0.0.

14. TURBO Button: Active/Disable Turbo function.

Turbo function enables the unit to reach the preset temperature at cooling or heating operation in the shortest time(if the indoor unit does not support this function, there is no corresponding operation happened when pressing this button.)

15. CLOCK Button: Used to set the remote clock.

16. LED Button: Disable/Active indoor screen Display.

### 3.1.2 RG51F/EU1(Standard for wall-mounted type)

#### Remote Controller Specifications

Model	RG51F/EU1, RG51F3/EU1
Rated Voltage	3.0V (Dry batteries R03/LR03×2)
Reaching Distance	8m
Environment Temperature Range	-5 °C ~60 °C (23 °F ~140 °F)

#### Buttons and Functions

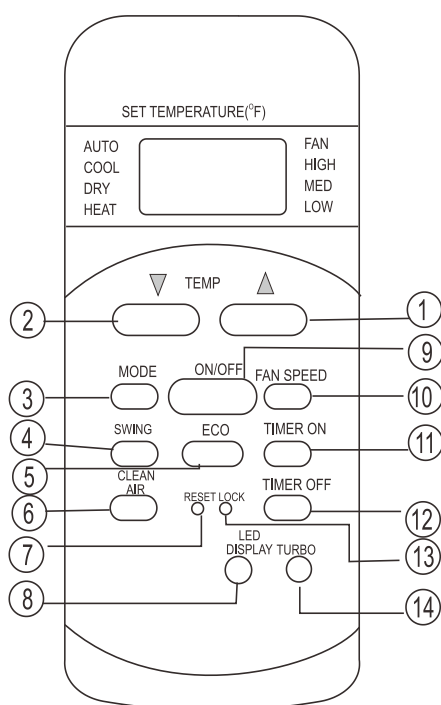

1. TEMP UP ▲ Button: Push this button to increase the indoor temperature setting in 1 °C increments to 30 °C
2. TEMP DOWN ▼ Button : Push this button to decrease the indoor temperature setting in 1 °C increments to 17 °C .
3. MODE Button: Once pressing, running mode will be selected in the following sequence:

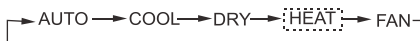

NOTE: No heating mode for cool only type unit.

4. SWING Button: Used to stop or start horizontal louver movement or set the desired up/down air flow direction. The louver changes 6 degree in angle for each press. If keep pushing more than 2 seconds, the louver will swing up and down automatically.
5. ECO Button: Used to enter the energy efficient mode. Under cooling mode, press this button, the remote controller will adjust the temperature automatically to 75°F, fan speed of Auto to save energy(but only if the set temperature is less than 75°F). If the set temperature is between 75°F and 86°F, press the ECO button, the fan speed will change to Auto, the set temperature will remain unchanged.

NOTE: Pressing the TURBO and SLEEP button, modifying the mode or adjusting the set temperature to less than 75°F will stop ECO operation.

Under ECO operation, the set temperature should be 75°F or more. it may result in insufficient cooling. If you feel uncomfortable, just press the ECO button again to stop it.

6. CLEAN AIR Button(applicable to RG51F3/EU1): Disable/Active clean air function. When the clean air function is initiated, the Ionizer/Plasma Dust Collector(depending on models) is energized and will help to remove pollen and impurities from the air.

7. RESET Button (inner located): Once the recessed RESET button is pressed, all of the current settings will be cancelled and the controller will return to the initial settings.

8. LED DISPLAY Button: Disable/Active indoor screen Display. When pushing the button, the indoor screen display is cleared, press it again to light the display.

9. ON/OFF Button: Operation starts when this button is pressed and stops when the button is pressed again.

10. FAN SPEED Button: Fan speed will be selected in following sequence once pressing this button:

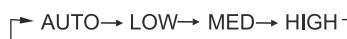

11. TIME ON Button: For time ON setting. Press this button to activate the Auto-on time setting. Each press will increase the time setting in 30 minutes increments, up to 10 hours, then at 1 hour increments up to 24 hours. To cancel the Auto-on time setting, just press the button until the time setting is 0.0.

12. TIME OFF Button: For time OFF setting. Press this button to activate the Auto-off time setting. Each press will increase the time setting in 30 minutes increments, up to 10 hours, then at 1 hour increments up to 24 hours. To cancel the Auto-off time setting, just press the button until the time setting is 0.0.

13. LOCK Button(inner located): When you press the recessed LOCK button, all current settings are locked in and the remote controller does not accept any operation except that of the LOCK. Press again to cancel the LOCK mode.

14. TURBO Button: Active/Disable Turbo function. Turbo function enables the unit to reach the preset temperature at cooling or heating operation in the shortest time(if the indoor unit does not support this function, there is no corresponding operation happened when pressing this button.)

## 3.2 LCD Wired Remote Controller

### 3.2.1 LCD Wired Remote Controller KJR-12B/DP(T) (Standard)

The KJR-12B/DP(T) wired remote controller is standard for Duct type.

#### i) Buttons and Functions

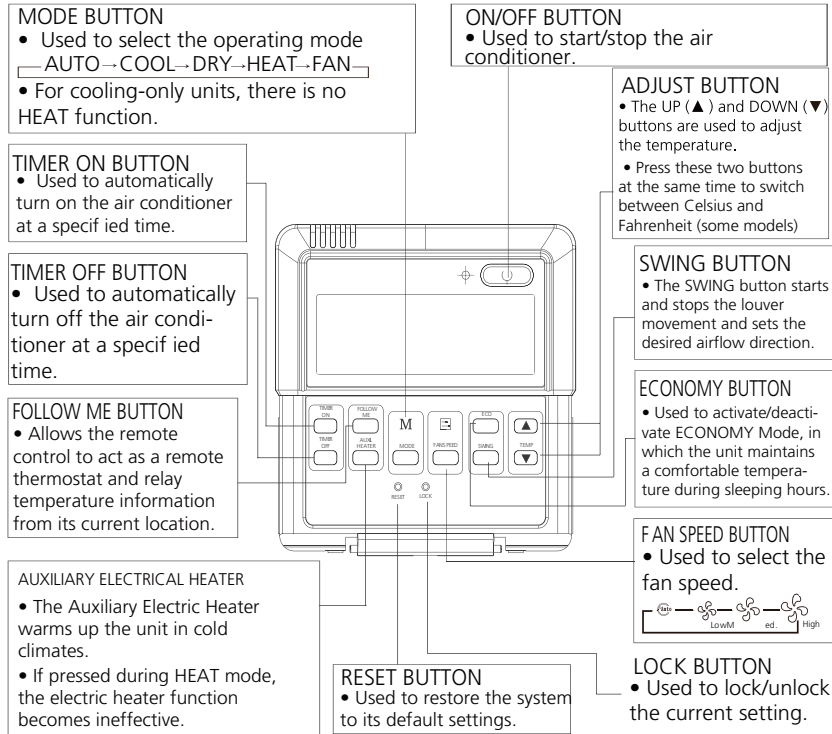

#### ii) LCD Screen

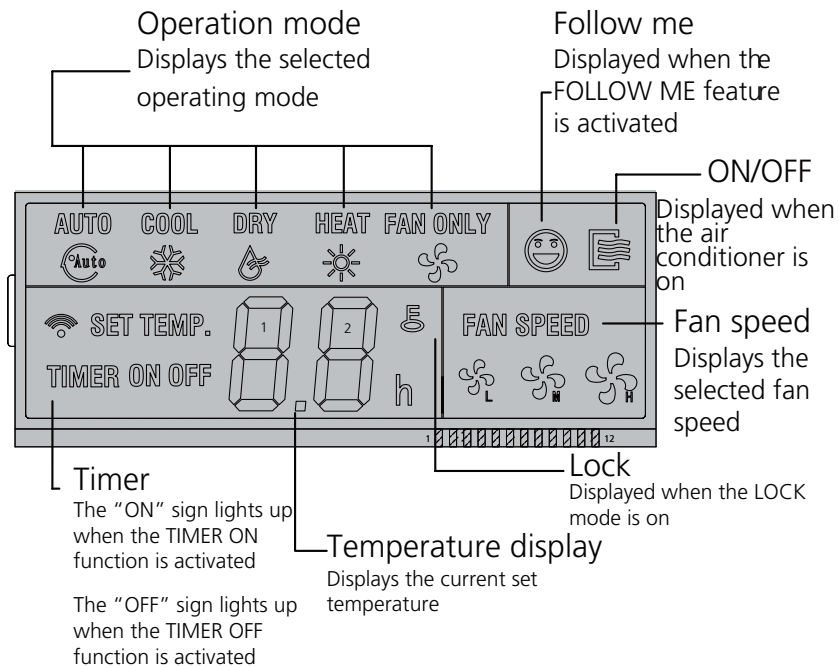

### iii) Installation

- Dimensions

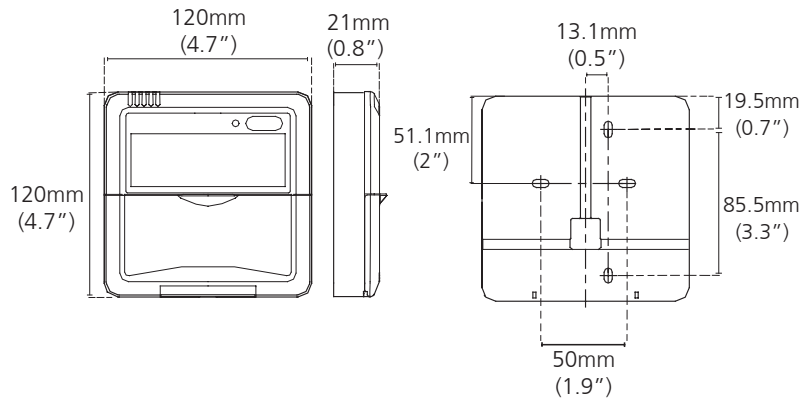

- Wiring diagram

Refer to the following diagram to wire the Wall mounted type remote control to the indoor unit.

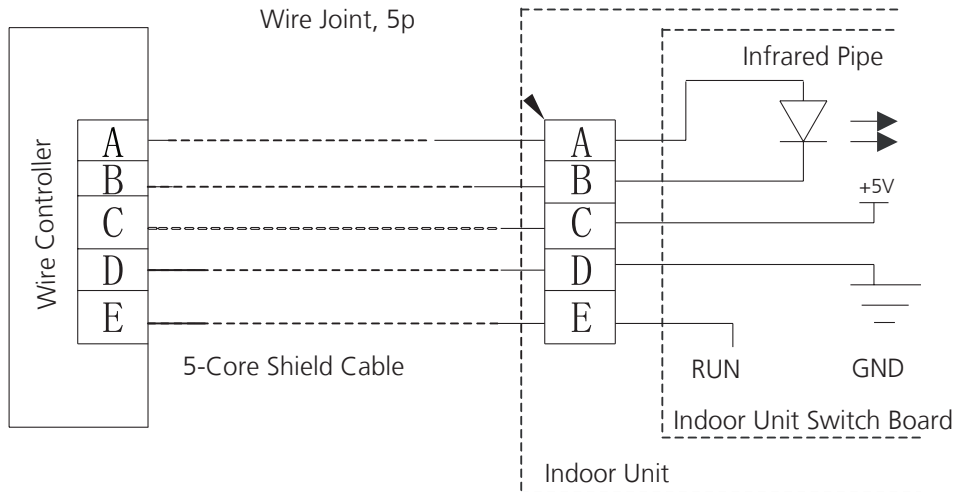

- Installation Diagram

Connect the wire from the display panel of the indoor unit to a connecting cable. Then connect the other side of the connecting cable to the remote control.

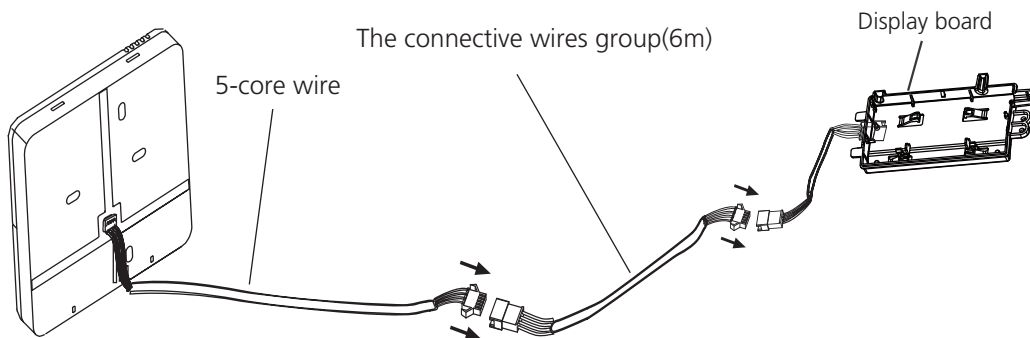

**Note:** Be sure to reserve a length of the connecting wire for periodic maintenance.

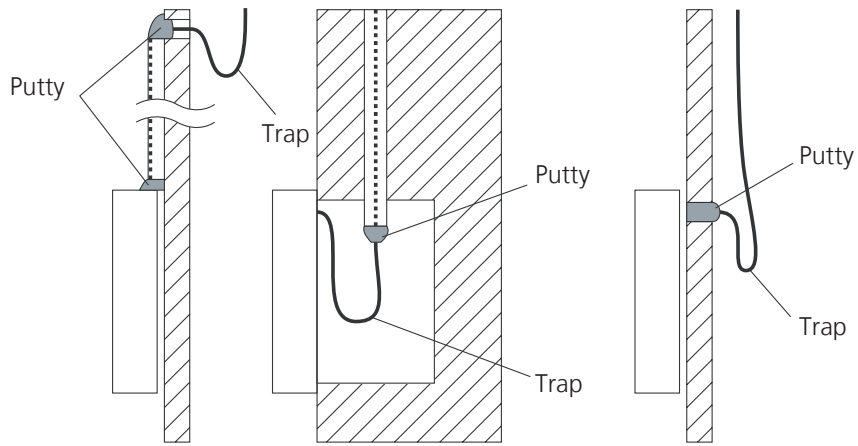

**Note: DO NOT** allow water to enter the remote control. Use the trap and putty to seal the wires.

- For exposed mounting, cut holes on four of the sides according to the picture below.

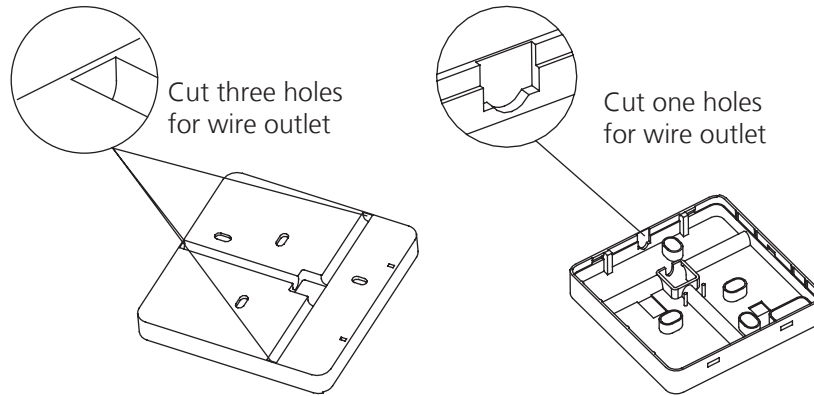

- For shielded wiring, please refer to the picture below.

Embedded switch box wiring

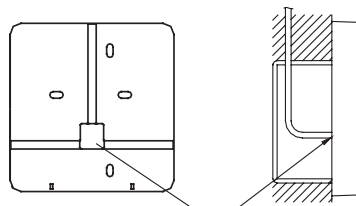

Wiring hole

Wiring through the wall

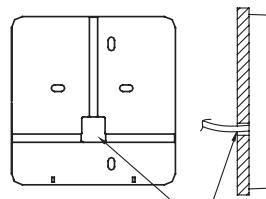

Wall hole and wiring hole  
Diameter of wall hole:  $\Phi$  2cm

### 3.2.2 LCD Wired Remote Controller KJR-120C/TF-E(Optional)

The KJR-120C/TF-E wired remote controller is optional for all types.

#### i) Buttons and Functions

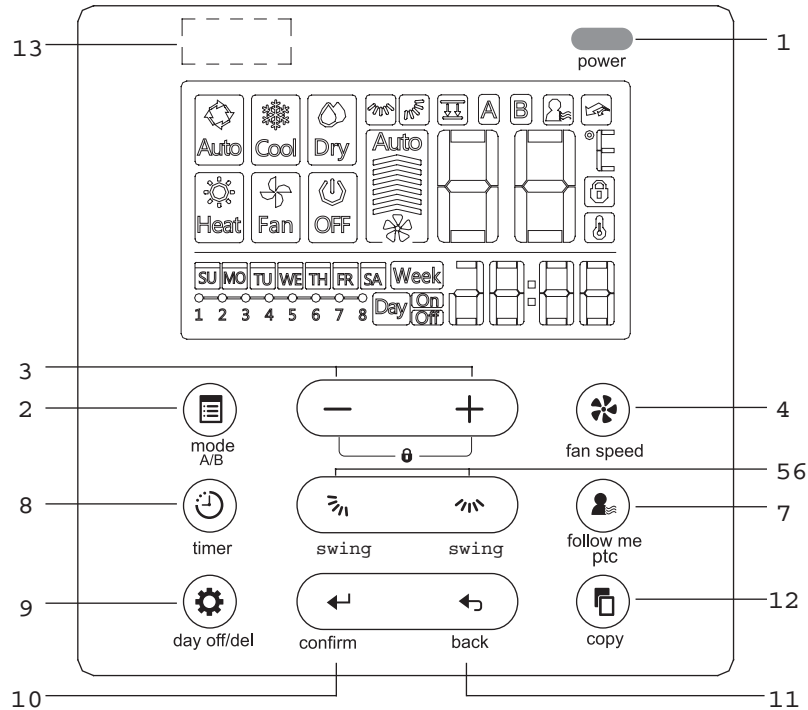

**1. POWER button**

Turn on or turn off the unit.

**2. MODE(A/B) button**

Used to select the operation mode: Auto / Cooling / Drying / Heating / Fan;

Hold to activate the operation of auto-lifting panel when off

**3. Adjust button**

To set temperature, time and timer; set up or down the auto-lifting panel

**4. FAN SPEED button**

Used to select the fan speed.

**5. Up-down airflow direction and swing Button**

Press for adjusting the angel of louver, hold for vertical swing; individual louver control for cassette panel

**6. Left-right airflow swing Button**

Press for activating the horizontal swing

**7. FOLLOW ME(PTC) button**

Allows the remote control to act as a remote thermostat and send temperature information from its current location.

**8. TIMER button**

To set timer on and timer off time of one day

**9. DELAY/DAY OFF button**

To set 1 to 2 hours delay off for each day or a whole day off in a weekly timer schedule

**10. CONFIRM button**

To confirm an setting or call up the menu

**11. BACK button**

Back to previous operation or superior menu

**12. COPY button**

Copy timer setting of one day to another in weekly schedule setting

**13 Infrared remote receiver (on some models)**

## ii) LCD Screen

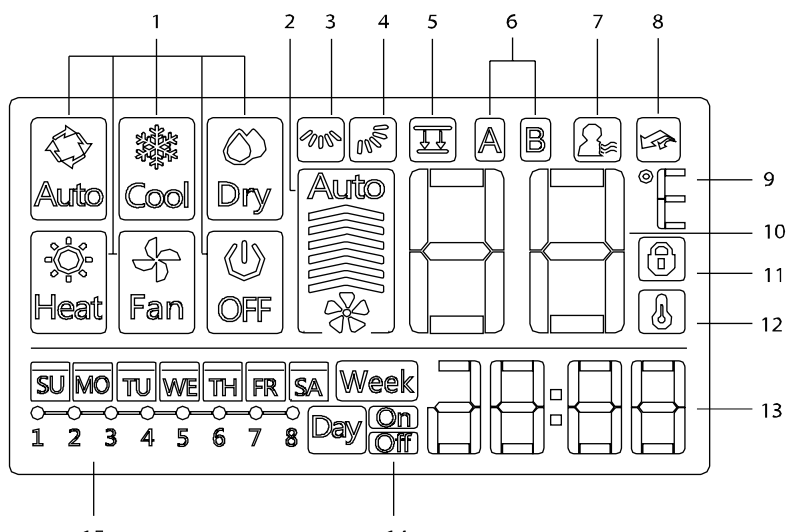

1 Operation mode indication

2 Fan speed indication

3 Left-right swing indication

4 Up-down swing indication

5 Faceplate function indication

6 Main unit and secondary unit indication

7 Follow me function indication

8 PTC function indication

9 C° / F° indication

10 Temperature display

11 Lock indication

12 Room temperature indication

13 Clock display

14 On/Off timer

15 Timer display



### iii) Installation

- Dimensions

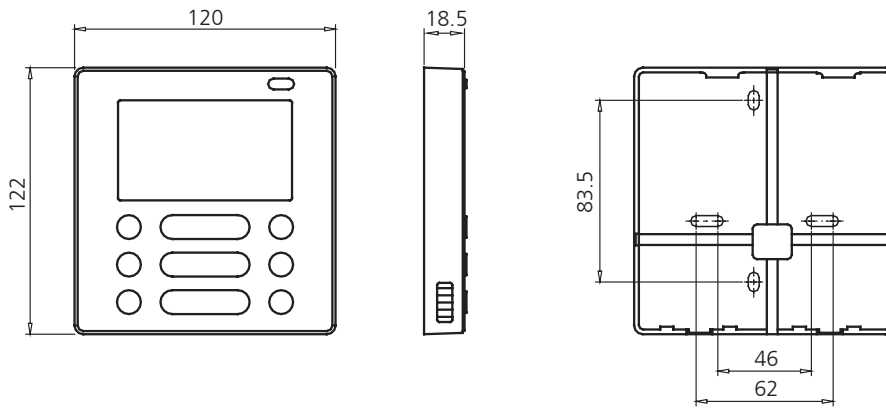

- Wiring diagram

Refer to the following diagram to wire the Wall mounted type remote control to the indoor unit.

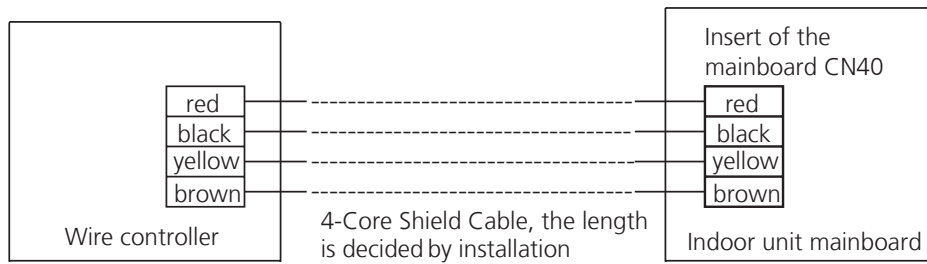

- Installation Diagram

Connect the female joint of wires group from the mainboard with the male joint of connective wires group. Then connect the other side of connective wires group with the male joint of wires group leads from wire controller.

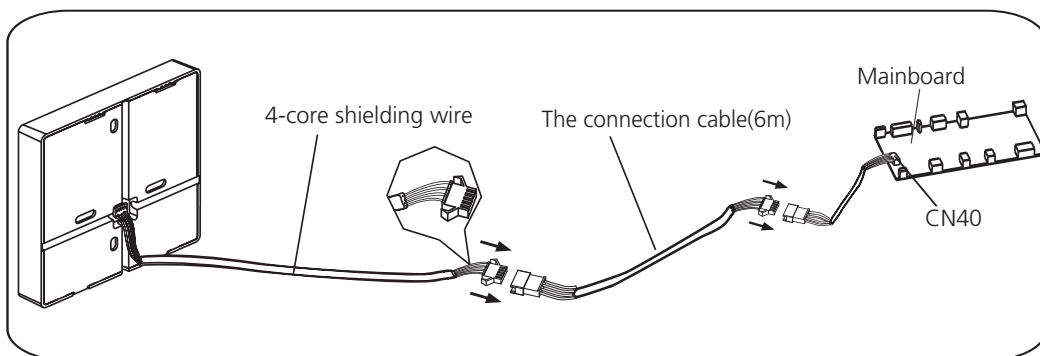

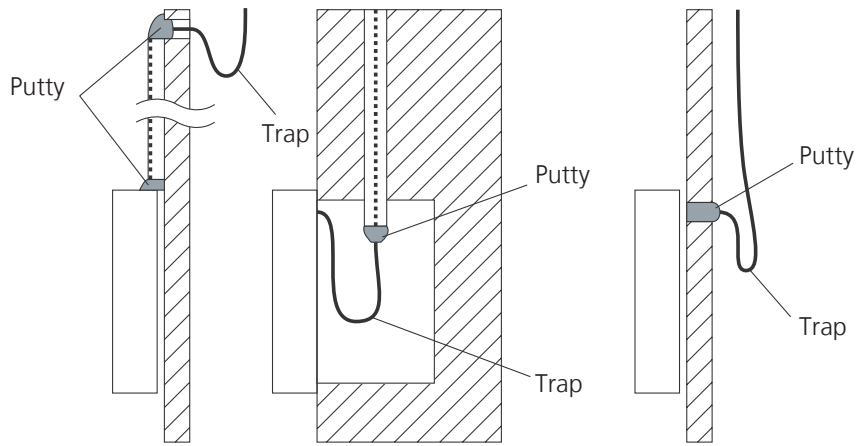

**Note: DO NOT** allow water to enter the remote control. Use the trap and putty to seal the wires.

- For exposed mounting, four outletting positions. There are three need cutting.

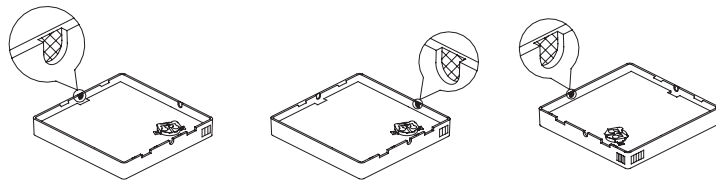

Cutting place of top side wire outlet

Cutting place of left side wire outlet

Cutting place of right side wire outlet

- For shielded wiring, please refer to the picture below.

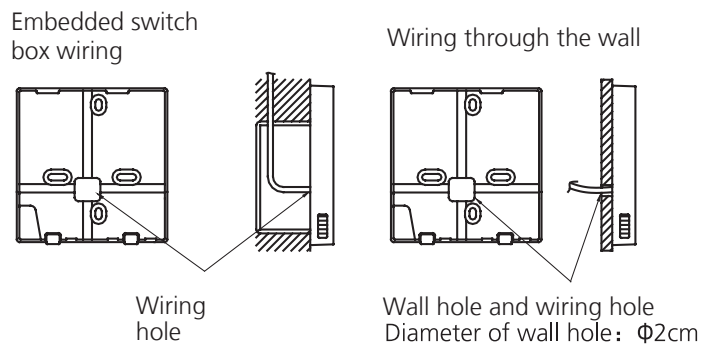

### 3.2.3 LCD Wired Remote Controller KJR-120G/TF-E(Optional)

The KJR-120G/TF-E wired remote controller is optional for all types.

#### i) Buttons and Functions

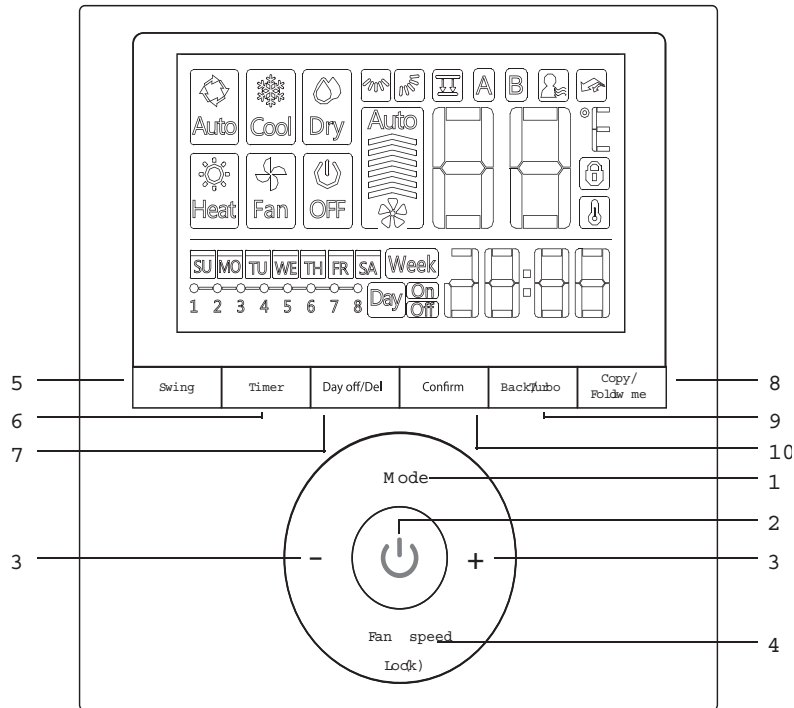

#### 1. MODE button

Used to select the operation mode: Auto / Cooling / Drying / Heating / Fan;

Hold to active the operation of auto-lifting panel when off

#### 2. POWER button

Turn on of turn off the unit.

#### 3. Adjust button

To set temperature, time and timer; set up or down the auto-lifting panel

#### 4. FAN SPEED button

Used to select the fan speed.

#### 5. Swing Button

Press to active vertical swing, hold for horizontal swing

#### 6. TIMER button

To set timer on and timer off time of one day

#### 7. DELAY/DAY OFF button

To set 1 to 2 hours delay off for each day or a whole day off in a weekly timer schedule

#### 8. COPY/FOLLOW ME button

To copy timer setting of one day to another in weekly schedule setting;

To active the follow me function while in normal operation.

#### 9. BACK/TURBO button

Back to previous operation or superior menu

To active turbo mode while in normal operation

#### 10. CONFIRM button

To confirm an setting or call up the superior menu

## ii) LCD Screen

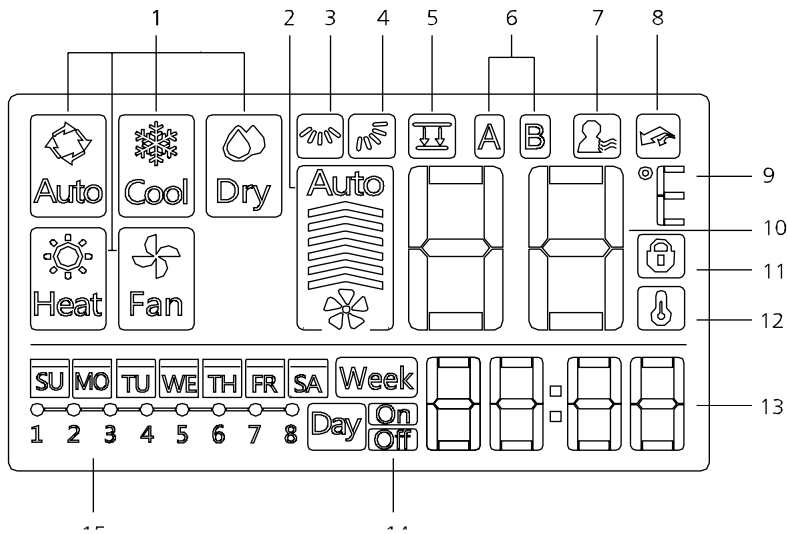

1 Operation mode indication

2 Fan speed indication

3 Left-right swing indication

4 Up-down swing indication

5 Faceplate function indication

6 Main unit and secondary unit indication

7 Follow me function indication

8 Turbo/PTC function indication

9 C° / F° indication

10 Temperature display

11 Lock indication

12 Room temperature indication

13 Clock display

14 On/Off timer

15 Timer display

### iii) Installation

- Dimensions

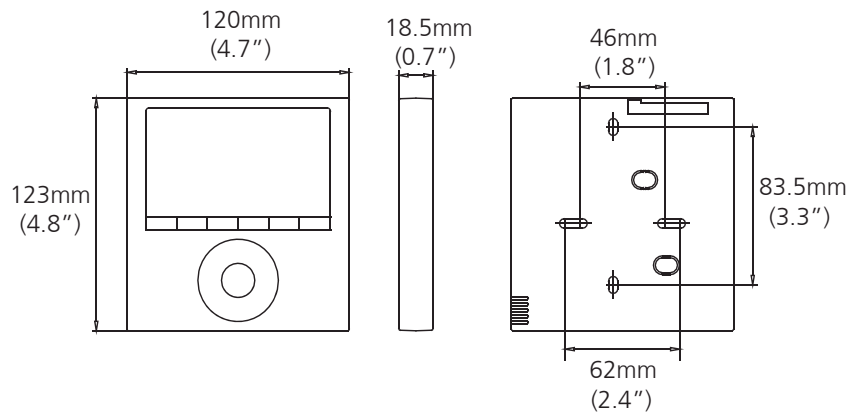

- Wiring diagram

- 1) Connection

For Cassette type: The wired controller connects to main control board directly.

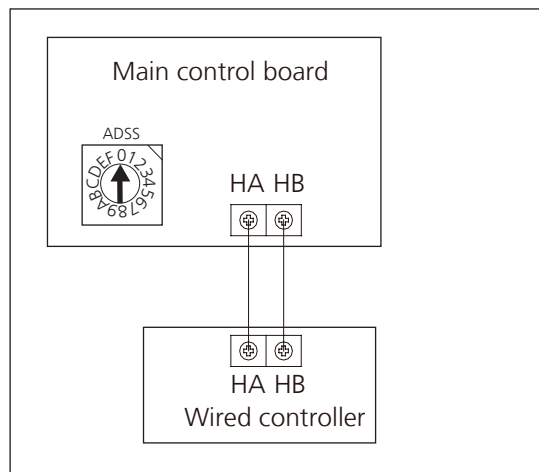

For Duct, Ceiling & floor: The wired controller connects to terminal board, terminal board connects to main control board.

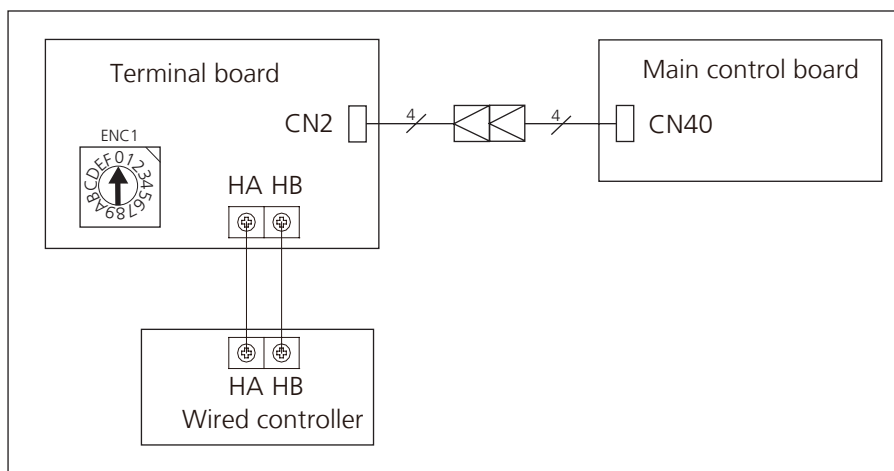

## 2) Address setting

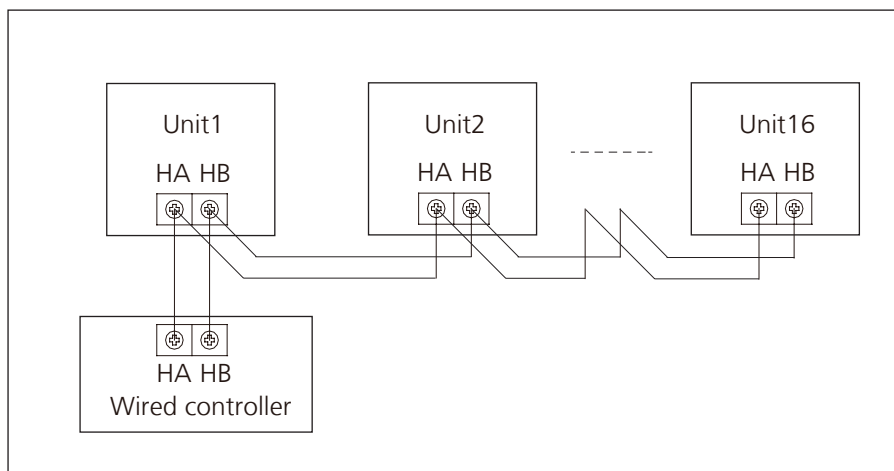

- One non-polarity controller can control up to 16 indoor units.
- When the non-polarity controller is connected to several units, every air-conditioner in network has only one network address to distinguish each other.
- Address code of air-conditioner in LAN is set by code switch ENC1(Duct and Ceiling& Floor) or ADSS(Cassette) of the indoor unit, and the set range is 0-15.
- Note: The indoor units are controlled at the same time, not independently. The purpose of setting network address is identify the unit when error occurs.

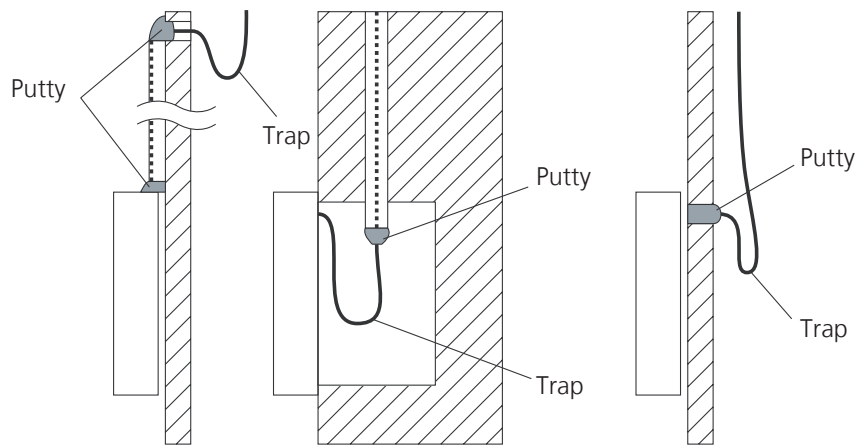

**Note: DO NOT** allow water to enter the remote control. Use the trap and putty to seal the wires.

• **For wiring the indoor unit, there are three methods:**

- From the rear;
- From the bottom;
- From the top;
- From the top center.

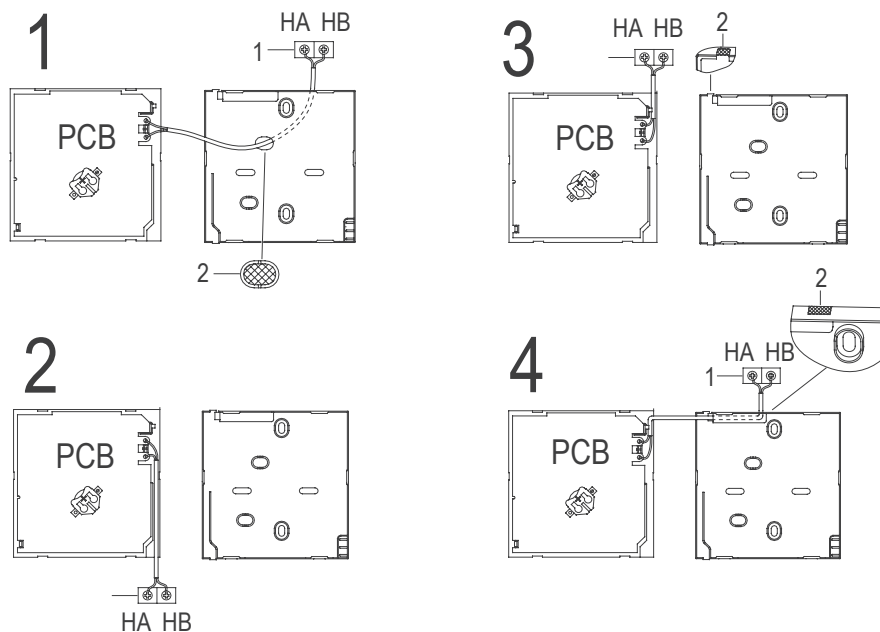

- 1: Indoor Unit.
- 2: Notch the part for the wiring to pass through with a nipper tool.
- Connect the terminals on the remote controller (HA ,HB), and the terminals of the indoor unit. (HA ,HB). (HA and HB do not have polarity.)

### 3.3 Centralized Controller

#### 1) Connection

For Light commercial air conditioner with XYE port, it can be directly connected to Centralized Controller (CCM03, CCM09).

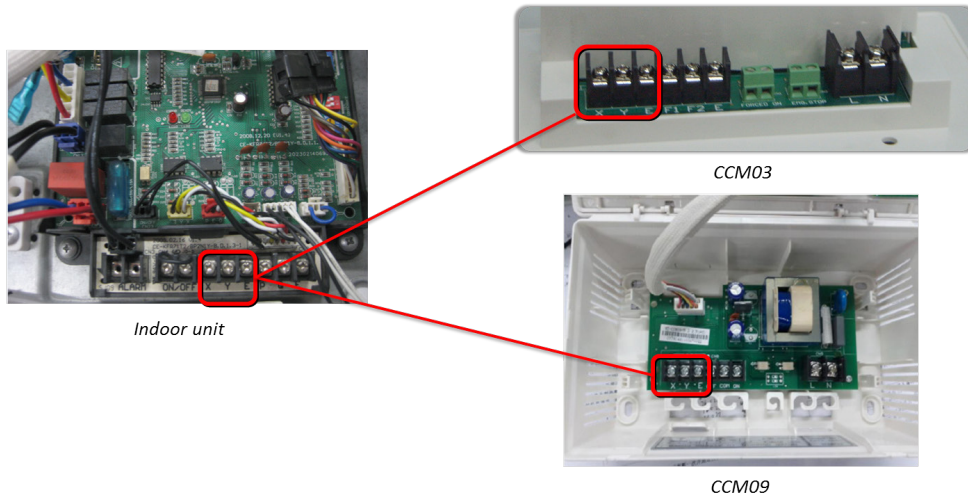

Indoor unit

CCM03

CCM09

#### 2) Address setting

When setting the address, please make sure the unit is powered off. The address can be set from 0 to 63 by the switch. Turn on the unit, then the address will be effective.

SWITCH		FOR CCM UNIT ADDRESS	
S2 + S1			
ADDRESS	0~15		16~31
Factory Setting	✓		
S2 + S1			
ADDRESS	32~47		48~63
Factory Setting			

Note: For light commercial air conditioner with XYE port, it can be also connected to BMS (Building Management System).

If there is any CAC (central air conditioner) connecting with the central controller at the same time, please set the address from largest (63,62,61...), since the CAC units could obtain address automatically from the smallest (00,01,02...)



### 3.4 Using the wire controller to set external static pressure

- You can use the unit’s automatic airflow adjustment function to set external static pressure.
- Automatic airflow adjustment is the volume of blow-off air that has been automatically adjusted to the quantity rated.

1. Make sure the test run is done with a dry coil. If the coil is not dry, run the unit for 2 hours in FAN ONLY mode to dry the coil.

2. Check that both power supply wiring and duct installation have been completed. Check that any closing dampers are open. Check that the air filter is properly attached to the air suction side passage of the unit.

3. If there is more than one air inlet and outlet, adjust the dampers so that the airflow rate of each air inlet and outlet conforms with the designed airflow rate. Make sure the unit is in FAN ONLY mode. Press and set the airflow adjustment button on the remote control to change the airflow rate from H or L.

4. Set the parameters for automatic airflow adjustment. When the air conditioning unit is off, perform the following steps:

- When the unit is turned off, hold the MODE button and FAN button down together for three seconds. (“AF” indicator flashes for 3 times.)

- Press “Δ” or “∇” to select the AF.

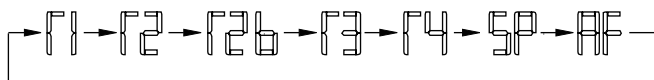

- Press “MODE”. The air conditioning unit will then start the fan for airflow automatic adjustment.

After 3 to 6 minutes, the air conditioning unit stops operating once automatic airflow adjustment has finished.

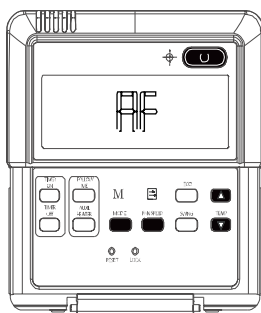

Caution: DO NOT adjust the dampers when automatic airflow adjustment is active.

Caution:

• If there is no change after airflow adjustment in the ventilation paths, be sure to reset automatic airflow adjustment.

• If there is no change to ventilation paths after airflow adjustment, contact your dealer, especially if this occurs after testing the outdoor unit or if the unit has been moved to a different location.

• Do not use automatic airflow adjustment with remote control, if you are using booster fans, outdoor air processing unit, or a HRV via duct.

• If the ventilation paths have been changed, reset airflow automatic adjustment as described from step 3 onwards.

### 3.5 Using the wire controller to set airflow rate

When the air conditioning unit is off, perform the following steps:

1. Press “MODE” and “FAN” for three seconds.

2. Press “Δ” or “∇” to select the SP.

3. Press “MODE” to set the airflow rate in the range of 0~4.

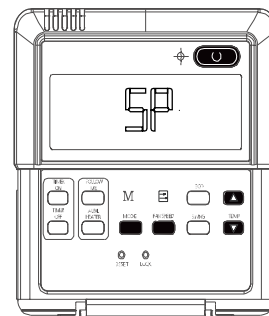

“0”: No airflow change

“1”~“4”: Airflow increase progressively

4. Press “ON/OFF” to finish the airflow setting.

---

# Troubleshooting

## Contents

<b>1.</b>	<b>Safety Caution .....</b>	<b>124</b>
<b>2.</b>	<b>General Troubleshooting .....</b>	<b>125</b>
2.1	Error Display (Indoor Unit).....	125
2.2	Error Display (Outdoor Unit).....	127
<b>3.</b>	<b>Complain Record Form .....</b>	<b>128</b>
<b>4.</b>	<b>Information Inquiry .....</b>	<b>130</b>
<b>5.</b>	<b>Outdoor Unit Point Check Function .....</b>	<b>133</b>
<b>6.</b>	<b>Error Diagnosis and Troubleshooting Without Error Code.....</b>	<b>136</b>
6.1	Remote maintenance.....	136
6.2	Field maintenance .....	137
<b>7.</b>	<b>Quick Maintenance by Error Code.....</b>	<b>142</b>
<b>8.</b>	<b>Troubleshooting by Error Code.....</b>	<b>143</b>
	TS01-IDU: Indoor EEPROM parameter error diagnosis and solution	
	TS01-ODU: Outdoor EEPROM parameter error or Compressor driven chip EEPROM parameter error diagnosis and solution	
	TS02-M: Indoor and outdoor units communication error diagnosis and solution	
	TS03 Zero-crossing Signal Detection Error Diagnosis and Solution	
	TS04-L-IDU: The Indoor fan speed is operating outside of normal range diagnosis and solution)	
	TS04-ODU: The outdoor fan speed is operating outside of normal range diagnosis and solution)	

---

# Contents

TS05-IDU: Open circuit or short circuit of indoor temperature sensor(T1, T2) diagnosis and solution

TS05-ODU: Open circuit or short circuit of outdoor temperature sensor(T3, T4, TP, T2B,TH) diagnosis and solution

TS08-L-INV: Current overload protection diagnosis and solution

TS09-L: IPM malfunction or IGBT over-strong current protection or Inverter compressor drive error diagnosis and solution

TS10-L: Over voltage or too low voltage protection diagnosis and solution

TS11-L: Top temperature protection of compressor diagnosis and solution

TS14: Indoor units mode conflict (match with multi outdoor unit)

TS15: Water-Level Alarm Malfunction Diagnosis and Solution

TS23: Communication error between indoor two chips diagnosis and solution

TS13-INV: Low pressure protection diagnosis and solution

TS28: High pressure protection diagnosis and solution

TS31: Communication error between outdoor main PCB and IPM board diagnosis and solution

TS32: Discharge temperature protection of compressor diagnosis and solution

TS27-INV: High temperature protection of condenser diagnosis and solution

TS30: PFC module protection diagnosis and solution

**9. Check Procedures.....177**

## 1. Safety Caution

### ⚠ WARNING

Be sure to turn off all power supplies or disconnect all wires to avoid electric shock. While checking indoor/outdoor PCB, please equip oneself with antistatic gloves or wrist strap to avoid damage to the board.

### ⚠ WARNING

Electricity remains in capacitors even when the power supply is off. Ensure the capacitors are fully discharged before troubleshooting.

Test the voltage between P and N on back of the main PCB with multimeter. If the voltage is lower than 36V, the capacitors are fully discharged.

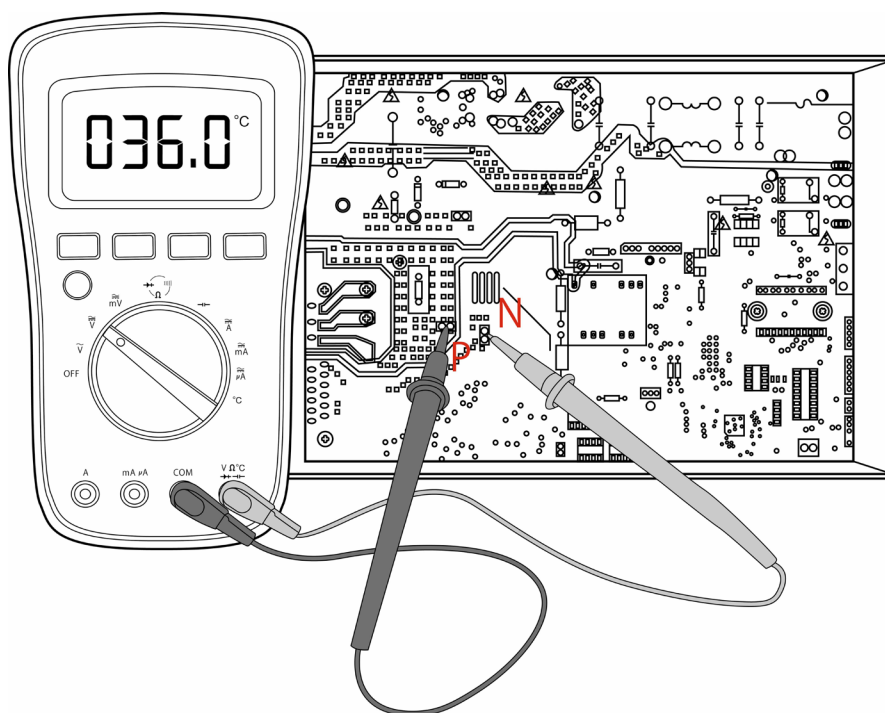

Note: This picture is for reference only. Actual appearance may vary.

## 2. General Troubleshooting

### 2.1 Error Display (Indoor Unit)

When the indoor unit encounters a recognized error, the operation lamp will flash in a corresponding series, the timer lamp may turn on or begin flashing, and an error code will be displayed. These error codes are described in the following tables:

Operation Lamp	Timer Lamp	Display	Error Information	Solution
--	--	<b>dF</b>	Defrost	--
--	--	<b>CF</b>	Warming in heating mode	--
--	--	<b>SC</b>	Self clean	--
--	--	<b>CL</b>	Clean filter	--
--	--	<b>RF</b>	Replacing filter	--
--	--	<b>FP</b>	Heating in room temperature under 8°C	--
--	--	<b>FC</b>	Forced cooling	--
--	--	<b>RP</b>	AP mode of WIFI connection	--
--	--	<b>CP</b>	Remote switched off	--
1 time	OFF	<b>E0</b>	Indoor unit EEPROM parameter error	TS01-IDU
2 times	OFF	<b>E1</b>	Indoor / outdoor units communication error	TS02-M
3 times	OFF	<b>E2</b>	Zero-crossing signal detection error(for some models)	TS03
4 times	OFF	<b>E3</b>	The indoor fan speed is operating outside of the normal range	TS04-L-IDU
5 times	OFF	<b>E4</b>	Indoor room temperature sensor T1 is in open circuit or has short circuited	TS05-IDU
6 times	OFF	<b>E5</b>	Evaporator coil inlet temperature sensor T2 is in open circuit or has short circuited	TS05-IDU
8 times	OFF	<b>EE</b>	Water-level alarm malfunction(for some models)	TS15
1 times	ON	<b>F0</b>	Current overload protection	TS08-L-INV
2 times	ON	<b>F1</b>	Outdoor room temperature sensor T4 is in open circuit or has short circuited	TS05-ODU
3 times	ON	<b>F2</b>	Condenser coil temperature sensor T3 is in open circuit or has short circuited	TS05-ODU
4 times	ON	<b>F3</b>	Compressor discharge temperature sensor TP is in open circuit or has short circuited	TS05-ODU
5 times	ON	<b>F4</b>	Outdoor unit EEPROM parameter error	TS01-ODU
6 times	ON	<b>F5</b>	The outdoor fan speed is operating outside of the normal range(for some models)	TS04-ODU
7 times	ON	<b>F6</b>	Evaporator coil outlet temperature sensor T2B is in open circuit or has short circuited	TS05-ODU
11 times	<b>ON</b>	<b>FR</b>	Communication error between indoor two chips (for some models)	TS23

1 times	FLASH	P0	IPM malfunction or IGBT over-strong current protection	TS09-L
2 times	FLASH	P1	Over voltage or over low voltage protection	TS10-L
3 times	FLASH	P2	High temperature protection of IPM module or High pressure protection or Top temperature protection of compressor	TS11-L
4 times	FLASH	P3	Low ambient temperature protection	--
5 times	FLASH	P4	Inverter compressor drive error	TS09-L
6 times	FLASH	--/P5	Indoor units mode conflict	TS14
7 times	FLASH	P6	Low pressure protection	TS13-INV
8 times	FLASH	P7	Outdoor IGBT sensor is faulty(for some models)	TS05-ODU

### Troubleshooting:

Test the unit using the remote control. If the unit does not respond to the remote, the indoor PCB requires replacement. If the unit responds, the display board requires replacement.

## 2.2 Error Display (Outdoor Unit)

Display	Malfunction or Protection	Solution
dF	Defrost	--
FC	Forced cooling	--
RO	Oil return	--
PH	Compressor pre-heating	--
LC	Low ambient cooling	--
E0	Outdoor EEPROM malfunction	TS01-ODU
E2	Indoor/outdoor units communication error	TS02-M
E3	Communication error between outdoor main PCB and IPM board	TS31
E4	Open or short circuit of outdoor unit temperature sensor	TS05-ODU
E5	Over voltage or over low voltage protection	TS10-L
E6	PFC module protection	TS30
E8	The outdoor fan speed is operating outside of the normal range	TS04-ODU
F1	No A Indoor unit coil outlet temperature sensor or connector of sensor is defective	TS05-IDU
F2	No B Indoor unit coil outlet temperature sensor or connector of sensor is defective	TS05-IDU
F3	No C Indoor unit coil outlet temperature sensor or connector of sensor is defective	TS05-IDU
F4	No D Indoor unit coil outlet temperature sensor or connector of sensor is defective	TS05-IDU
F5	No E Indoor unit coil outlet temperature sensor or connector of sensor is defective	TS05-IDU
F6	No F Indoor unit coil outlet temperature sensor or connector of sensor is defective	TS05-IDU
P0	Top temperature protection of compressor	TS11-L
P1	High pressure protection	TS28
P2	Low pressure protection	TS13-INV
P3	Current overload protection	TS08-L-INV
P4	Temperature protection of compressor discharge	TS32
P5	High temperature protection of condenser	TS27-INV
P6	IPM module protection	TS09-L
LP	Low ambient temperature protection	--

### 3. Complain Record Form

#### Complain Record Form

Request No.:

Date:

Installation Date:

Service Date:

Customer Information			
Name		Telephone No.	
Home Address			
Email			
Product Information			
Indoor Unit Model		Outdoor Unit Model	
Serial No. of indoor unit			
Serial No. of outdoor unit			
Working Mode	<input type="checkbox"/> Cooling <input type="checkbox"/> Heating <input type="checkbox"/> Fan only <input type="checkbox"/> Dry		
Setting temperature	_____°C / °F	Fan speed	<input type="checkbox"/> Turbo <input type="checkbox"/> High <input type="checkbox"/> Medium <input type="checkbox"/> Low <input type="checkbox"/> Auto
Temperature of air inlet	_____°C / °F	Temperature of air outlet	_____°C / °F
Installation / Condition Information			
Indoor temperature	_____°C / °F	Indoor humidity	_____ %RH
Outdoor temperature	_____°C / °F	Outdoor humidity	_____ %RH
Length of Connecting pipe		Pipe diameter	Gas pipe:          Liquid pipe:
Length of Wiring		wire diameter	
System Running Pressure	_____MPa   or   _____Bar   or   _____PSI		
Room size (L*W*H)			
Photo of Installation of Indoor unit (Photo #1)		Photo of Installation of Outdoor unit (Photo #2)	
Failure Description			
Error Code of Indoor unit		Code of Outdoor PCB	
Unit does not start			
Remote control does not work			
Indoor display shows nothing			
No cooling or heating at all			
Less cooling or heating			
Unit starts but stops shortly			
High noise			
High vibration			
Parameter Checking information by Remote controller			
Displaying code	Displaying code meaning	Display value	Display value meaning
T1	Room temperature		



T2	Indoor coil temperature		
T3	Outdoor coil temperature		
T4	Ambient temperature		
Tb	Outlet temperature of indoor coil		
TP	Discharge temperature		
TH	Suction temperature		
FT	Targeted Frequency		
Fr	Actual Frequency		
IF	Indoor fan speed		
OF	Outdoor fan speed		
LA	EXV opening steps		
CT	Compressor continuous running time		
ST	Causes of compressor stop.		
A0, A1, b0, b1, b2, b3, b4, b5, b6, dL, Ac, Uo, Td, nA	Reserved		

Approval from Manufacturer	
<input type="checkbox"/> Approved	
<input type="checkbox"/> More Proof needed	
<input type="checkbox"/> Rejected	

---

## 4. Information Inquiry

- To enter information inquiry status, complete the following procedure within ten seconds:
  - Press LED(or DO NOT DISTURB) 3 times.
  - Press SWING(or AIR DIRECTION) 3 times.
- Finish 1 and 2 within 10 seconds, you will hear beeps for two seconds, which means the unit goes into parameter checking mode.
- Use the LED(or DO NOT DISTURB) and SWING(or AIR DIRECTION) buttons to cycle through information displayed.
- Pressing LED(or DO NOT DISTURB) will display the next code in the sequence. Pressing SWING(or AIR DIRECTION) will show the previous.
- The following table shows information codes. The screen will display this code for two seconds, then the information for 25 seconds.

Displayed code	Explanation	Displayed value	Meaning	Additional Notes
T1	Room temperature	-1F,-1E,-1d,-1c,-1b,-1A -19—99 A0,A1,...A9 b0,b1,...b9 c0,c1,...c9 d0,d1,...d9 E0,E1,...E9 F0,F1,...F9	-25,-24,-23,-22,-21,-20 -19—99 100,101,...109 110,111,...119 120,121,...129 130,131,...139 140,141,...149 150,151,...159	<ol style="list-style-type: none"> <li>All displayed temperatures use actual values.</li> <li>All temperatures are displayed in °C regardless of remote used.</li> <li>T1, T2, T3, T4, and T2B display ranges from -25 to 70 °C. TP display ranges from -20 to 130 °C.</li> <li>The frequency display ranges from 0 to 159HZ.</li> <li>If the actual values exceed or fall short of the defined range, the values closest to the maximum and minimum values will be displayed.</li> </ol>
T2	Indoor coil temperature			
T3	Outdoor coil temperature			
T4	Ambient temperature			
TB	Outlet temperature of indoor coil			
TP	Discharge temperature			
TH	Suction temperature			
FT	Targeted frequency			
FR	Actual frequency			
IF	Indoor fan speed	0 1,2,3,4	OFF Low speed, Medium speed, High speed, Turbo.	N/A Used for some large capacity motors.
OF	Outdoor fan speed	14-FF	Actual fan speed is equal to the display value converted to decimal value and multiplied by 10. This is measured in RPM.	Used for some small capacity motors. The display value is 14-FF (hexadecimal). The corresponding fan speed ranges from 200 to 2550RPM.
LR	EXV opening angle	0-FF	Actual EXV opening value is equal to the display value converted to decimal value and then multiplied by 2.	-
CT	Compressor continuous running time	0-FF	0-255 minutes	If the actual value exceeds or falls short of the defined range, the value closest to the maximum and minimum will be displayed.
ST	Causes of compressor stop	0-99	For a detailed explanation, contact technical support.	-

Displayed code	Explanation	Displayed value	Meaning	Additional Notes
R0	Reserved	0-FF	-	-
R1				
b0				
b1				
b2				
b3				
b4				
b5				
b6				
d0				
Rc				
Uo				
Td				
RR		0-63	-	-

## 5. Outdoor Unit Point Check Function

- A check switch is included on the outdoor PCB.
- Push SW1 to check the unit's status while running. The digital display shows the following codes each time the SW1 is pushed.

Number of Presses	Display	Remark
0	Normal display	Displays running frequency, running state, or malfunction code
1	Quantity of indoor units with working connection	Display Number of indoor unit
		1 1
		2 2
		3 3
		4 4
2	Outdoor unit running mode code	Standby: 0, Fan only: 1, Cooling: 2, Heating: 3, Forced cooling: 4, Forced defrosting: A
3	Indoor unit A capacity	The capacity unit is horse power. If the indoor unit is not connected, the digital display shows the following: "--" (9K:1HP,12K:1.2HP,18K:1.5HP)
4	Indoor unit B capacity	
5	Indoor unit C capacity	
6	Indoor unit D capacity	
7	Indoor unit E capacity	
8	Indoor unit A capacity demand code	
9	Indoor unit B capacity demand code	Norm code*HP (9K: 1HP,12K: 1.2HP,18K: 1.5HP)
10	Indoor unit C capacity demand code	
11	Indoor unit D capacity demand code	
12	Indoor unit E capacity demand code	
13	Outdoor unit amendatory capacity demand code	
14	The frequency corresponding to the total indoor units' amendatory capacity demand	
15	The frequency after the frequency limit	
16	The frequency sending to compressor control chip	

17	Indoor unit A evaporator outlet temperature (T2BA)	If the temperature is lower than -9°C, the digital display shows "-9." If the temperature is higher than 70°C, the digital display shows "70." If the indoor unit is not connected, the digital display shows: "--"
18	Indoor unit B evaporator outlet temperature (T2BB)	
19	Indoor unit C evaporator outlet temperature (T2BC)	
20	Indoor unit D evaporator outlet temperature (T2BD)	
21	Indoor unit E evaporator outlet temperature (T2BE)	
22	Indoor unit A room temperature (T1A)	If the temperature is lower than 0°C, the digital display shows "0." If the temperature is higher than 70°C, the digital display shows "70." If the indoor unit is not connected, the digital display shows: "--"
23	Indoor unit B room temperature (T1B)	
24	Indoor unit C room temperature (T1C)	
25	Indoor unit D room temperature (T1D)	
26	Indoor unit E room temperature (T1E)	
27	Indoor unit A evaporator temperature (T2A)	If the temperature is lower than -9°C, the digital display shows "-9." If the temperature is higher than 70°C, the digital display shows "70." If the indoor unit is not connected, the digital display shows: "--"
28	Indoor unit B evaporator temperature (T2B)	
29	Indoor unit C evaporator temperature (T2C)	
30	Indoor unit D evaporator temperature (T2D)	
31	Indoor unit E evaporator temperature (T2E)	
32	Condenser pipe temperature (T3)	
33	Outdoor ambient temperature (T4)	The display value is between 30–129°C. If the temperature is lower than 30°C, the digital display shows "30." If the temperature is higher than 99°C, the digital display shows single and double digits. For example, if the digital display shows "0.5", the compressor discharge temperature is 105°C.
34	Compressor discharge temperature (TP)	
35	AD value of current	
36	AD value of voltage	For example, the digital display tube shows "Cd", it means AD value is 205.

37	EXV open angle for A indoor unit	Actual data/4. If the value is higher than 99, the digital display shows single and double digits. For example, if the digital display shows "2.0", the EXV open angle is 120×4=480p.		
38	EXV open angle for B indoor unit			
39	EXV open angle for C indoor unit			
40	EXV open angle for D indoor unit			
41	EXV open angle for E indoor unit			
42	Frequency limit symbol	Bit7	Frequency limit caused by IGBT radiator	The display value is a hexadecimal number. For example, the digital display show 2A, then Bit5=1, Bit3=1, and Bit1=1.  This means that a frequency limit may be caused by T4, T3, or the current.
		Bit6	Frequency limit caused by PFC	
		Bit5	Frequency limit caused by T4.	
		Bit4	Frequency limit caused by T2.	
		Bit3	Frequency limit caused by T3.	
		Bit2	Frequency limit caused by T5.	
		Bit1	Frequency limit caused by current	
		Bit0	Frequency limit caused by voltage	
43	Average value of T2	(Sum T2 value of all indoor units)/(number of indoor units in good connection)		
44	Outdoor unit fan motor state	Off: 0, High speed:1, Medium speed: 2, Low speed: 3, Breeze:4, Super breeze: 5		
45	The last error or protection code	00 means no malfunction and protection		
46	F indoor unit capacity	Reserved		
47	F indoor unit capacity demand code			
48	F indoor unit evaporator outlet temperature (T2BF)			
49	F indoor unit room temperature (T1F)			
50	F indoor unit evaporator temperature (T2F)			
51	EXV open angle for F indoor unit			

### Automatic wiring/piping correction function

Press the "check switch" on the outdoor unit PCB board 5 seconds until LED display "CE", which mean this function is working, Approximately 5-10 minutes after the switch is pressed, the "CE" disappear the wiring/piping error will be corrected, and wiring/piping is properly connected.

## 6. Error Diagnosis and Troubleshooting Without Error Code

### WARNING

Be sure to turn off unit before any maintenance to prevent damage or injury.

### 6.1 Remote maintenance

**SUGGESTION:** When troubles occur, please check the following points with customers before field maintenance.

No.	Problem	Solution
1	Unit will not start	Page 139~140
2	The power switch is on but fans will not start	Page 139~140
3	The temperature on the display board cannot be set	Page 139~140
4	Unit is on but the wind is not cold(hot)	Page 139~140
5	Unit runs, but shortly stops	Page 139~140
6	The unit starts up and stops frequently	Page 139~140
7	Unit runs continuously but insufficient cooling(heating)	Page 139~140
8	Cool can not change to heat	Page 139~140
9	Unit is noisy	Page 139~140



## 6.2 Field maintenance

	Problem	Solution
1	Unit will not start	Page 141~142
2	Compressor will not start but fans run	Page 141~142
3	Compressor and condenser (outdoor) fan will not start	Page 141~142
4	Evaporator (indoor) fan will not start	Page 141~142
5	Condenser (Outdoor) fan will not start	Page 141~142
6	Unit runs, but shortly stops	Page 141~142
7	Compressor short-cycles due to overload	Page 141~142
8	High discharge pressure	Page 141~142
9	Low discharge pressure	Page 141~142
10	High suction pressure	Page 141~142
11	Low suction pressure	Page 141~142
12	Unit runs continuously but insufficient cooling	Page 141~142
13	Too cool	Page 141~142
14	Compressor is noisy	Page 141~142
15	Horizontal louver can not revolve	Page 141~142

1.Remote Maintenance	Electrical Circuit				Refrigerant Circuit								
Possible causes of trouble	Power failure												
	The main power tripped												
	Loose connections												
	Faulty transformer												
	The voltage is too high or too low												
	The remote control is powered off												
	Broken remote control												
	Dirty air filter												
	Dirty condenser fins												
	The setting temperature is higher/lower than the room's(cooling/heating)												
	The ambient temperature is too high/low when the mode is cooling/heating												
	Fan mode												
SILENCE function is activated(optional function)													
Frosting and defrosting frequently													
Unit will not start	☆	☆	☆	☆									
The power switch is on but fans will not start			☆	☆	☆								
The temperature on the display board cannot be set					☆	☆							
Unit is on but the wind is not cold(hot)								☆	☆	☆			
Unit runs, but shortly stops					☆			☆	☆				
The unit starts up and stops frequently					☆				☆			☆	
Unit runs continuously but insufficient cooling(heating)							☆	☆	☆		☆		
Cool can not change to heat													
Unit is noisy													
Test method / remedy	Test voltage												
	Close the power switch												
	Inspect connections - tighten												
	Change the transformer												
	Test voltage												
	Replace the battery of the remote control												
	Replace the remote control												
	Clean or replace												
	Clean												
	Adjust the setting temperature												
	Turn the AC later												
	Adjust to cool mode												
Turn off SILENCE function.													
Turn the AC later													

1.Remote Maintenance	Others					
Possible causes of trouble	Heavy load condition	Loosen hold down bolts and / or screws	Bad airproof	The air inlet or outlet of either unit is blocked	Interference from cell phone towers and remote boosters	Shipping plates remain attached
Unit will not start						
The power switch is on but fans will not start					☆	
The temperature on the display board cannot be set						
Unit is on but the wind is not cold(hot)						
Unit runs, but shortly stops						
The unit starts up and stops frequently				☆		
Unit runs continuously but insufficient cooling(heating)	☆		☆	☆		
Cool can not change to heat						
Unit is noisy		☆				☆
Test method / remedy	Check heat load	Tighten bolts or screws	Close all the windows and doors	Remove the obstacles	Reconnect the power or press <b>ON/OFF</b> button on remote control to restart operation	Remove them

2.Field Maintenance	Refrigerant Circuit														Others									
Possible causes of trouble	Compressor stuck	Shortage of refrigerant	Restricted liquid line	Dirty air filter	Dirty evaporator coil	Insufficient air through evaporator coil	Overcharge of refrigerant	Dirty or partially blocked condenser	Air or incompressible gas in refrigerant cycle	Short cycling of condensing air	High temperature condensing medium	Insufficient condensing medium	Broken compressor internal parts	Inefficient compressor	Expansion valve obstructed	Expansion valve or capillary tube closed completely	Leaking power element on expansion valve	Poor installation of feeler bulb	Heavy load condition	Loosen hold down bolts and / or screws	Shipping plates remain attached	Poor choices of capacity	Contact of piping with other piping or external plate	
Unit will not start																								
Compressor will not start but fans run	☆																							
Compressor and condenser (outdoor) fan will not start																								
Evaporator (indoor) fan will not start																								
Condenser (Outdoor) fan will not start																								
Unit runs, but shortly stops		☆	☆				☆	☆								☆	☆							
Compressor short-cycles due to overload		☆					☆	☆																
High discharge pressure							☆	☆	☆	☆	☆													
Low discharge pressure		☆												☆										
High suction pressure							☆							☆				☆	☆					
Low suction pressure		☆	☆	☆	☆	☆								☆	☆	☆								
Unit runs continuously but insufficient cooling		☆	☆	☆	☆	☆		☆	☆	☆				☆					☆			☆		
Too cool																								
Compressor is noisy							☆						☆							☆	☆		☆	
Horizontal louver can not revolve																								
Test method / remedy	Replace the compressor	Leak test	Replace restricted part	Clean or replace	Clean coil	Check fan	Change charged refrigerant volume	Clean condenser or remove obstacle	Purge, evacuate and recharge	Remove obstruction to air flow	Remove obstruction in air or water flow	Remove obstruction in air or water flow	Replace compressor	Test compressor efficiency	Replace valve	Replace valve	Replace valve	Fix feeler bulb	Check heat load	Tighten bolts or screws	Remove them	Choose AC of lager capacity or add the number of AC	Rectify piping so as not to contact each other or with external plate	

2.Field Maintenance	Electrical Circuit														
Possible causes of trouble	Power failure	Blown fuse or varistor	Loose connections	Shorted or broken wires	Safety device opens	Faulty thermostat / room temperature sensor	Wrong setting place of temperature sensor	Faulty transformer	Shorted or open capacitor	Faulty magnetic contactor for compressor	Faulty magnetic contactor for fan	Low voltage	Faulty stepping motor	Shorted or grounded compressor	Shorted or grounded fan motor
Unit will not start	☆	☆	☆	☆	☆			☆							
Compressor will not start but fans run				☆		☆			☆	☆				☆	
Compressor and condenser (outdoor) fan will not start				☆		☆				☆					
Evaporator (indoor) fan will not start				☆					☆		☆				☆
Condenser (Outdoor) fan will not start				☆		☆			☆		☆				☆
Unit runs, but shortly stops										☆		☆			
Compressor short-cycles due to overload										☆		☆			
High discharge pressure															
Low discharge pressure															
High suction pressure															
Low suction pressure															
Unit runs continuously but insufficient cooling															
Too cool						☆	☆								
Compressor is noisy															
Horizontal louver can not revolve			☆	☆									☆		
Test method / remedy	Test voltage	Inspect fuse type & size	Inspect connections - tighten	Test circuits with tester	Test continuity of safety device	Test continuity of thermostat / sensor & wiring Place the temperature sensor at the central of the air inlet grille.	Check control circuit with tester	Check capacitor with tester	Test continuity of coil & contacts	Test continuity of coil & contacts	Test voltage	Replace the stepping motor	Check resistance with multimeter	Check resistance with multimeter	

## 7. Quick Maintenance by Error Code

If you do not have the time to test which specific parts are faulty, you can directly change the required parts according to the error code.

You can find the parts to replace by error code in the following table.

Part requiring replacement	Error Code										
	(I)E0/ FR	(I)E1/ (O)E2	(I)E3	(I)E4	(I)E5	(O)E4	(O)E4	(I)F1	(I)F2	(I)F3	(I)EE
Indoor PCB	✓	✓	✓	✓	✓	x	x	x	x	x	✓
Outdoor PCB	x	✓	x	x	x	✓	✓	✓	✓	✓	x
Indoor fan motor	x	x	✓	x	x	x	x	x	x	x	x
T1 sensor	x	x	x	✓	x	x	x	x	x	x	x
T2 Sensor	x	x	x	x	✓	x	x	x	x	x	x
T3 Sensor	x	x	x	x	x	✓	✓	x	✓	x	x
T4 Sensor	x	x	x	x	x	✓	✓	✓	x	x	x
TP Sensor	x	x	x	x	x	✓	✓	x	x	✓	x
Reactor	x	✓	x	x	x	x	x	x	x	x	x
IPM module board	x	✓	x	x	x	x	x	x	x	x	x
water-level switch	x	x	x	x	x	x	x	x	x	x	✓
Water pump	x	x	x	x	x	x	x	x	x	x	✓

Part requiring replacement	(I)F6/ (O)F1/ F2/F3/ F4	(I)F4/ (O)E0	(I)F5/ (O)E8	(I)F0/ (O)P3	(I)P3/ P4/ (O)P6	(I)P1/ (O)E5	(O)E3	(O)E6	(O)P4	(O)P5
Outdoor PCB	✓	✓	✓	✓	✓	✓	✓	✓	✓	✓
Outdoor fan motor	x	x	✓	✓	✓	x	x	x	x	✓
T3 Sensor	x	x	x	x	x	x	x	x	x	✓
T4 Sensor	x	x	x	x	x	x	x	x	x	x
TP Sensor	x	x	x	x	✓	x	x	x	✓	x
T2B Sensor	✓	x	x	x	x	x	x	x	x	x
Reactor or inductance	x	x	x	✓	✓	✓	x	✓	x	x
Compressor	x	x	x	✓	✓	x	x	x	x	x
IPM module board	x	x	x	✓	✓	✓	✓	✓	x	x
Bridge rectifier	x	x	x	✓	✓	✓	x	x	x	x
PFC module	x	x	x	x	x	x	x	x	x	x
Additional refrigerant	x	x	x	✓	x	x	x	x	✓	✓
Electric control box	x	x	x	x	x	x	✓	x	x	x

## 8. Troubleshooting by Error Code

### TS01-IDU: Indoor EEPROM parameter error diagnosis and solution

**Description:** Indoor PCB main chip does not receive feedback from EEPROM chip.

**Recommended parts to prepare:**

- Indoor PCB

**Troubleshooting and repair:**

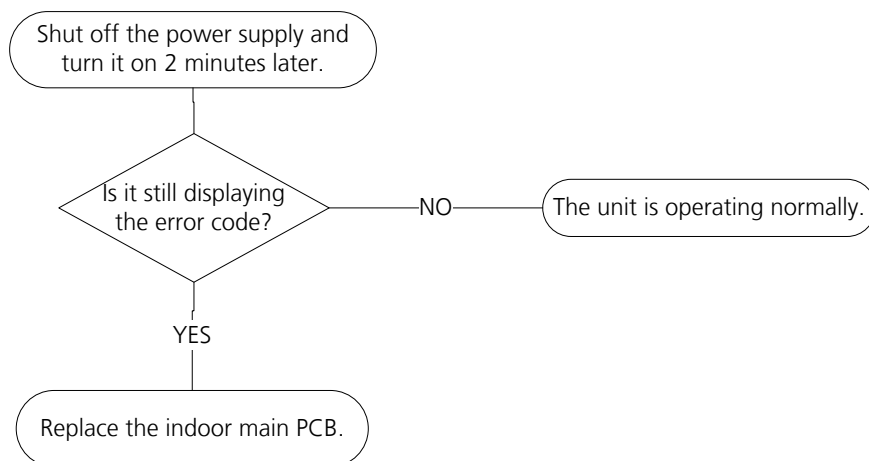

**Remarks:**

**EEPROM:** A read-only memory whose contents can be erased and reprogrammed using a pulsed voltage.

The location of the EEPROM chip on the indoor PCB is shown in the following image:

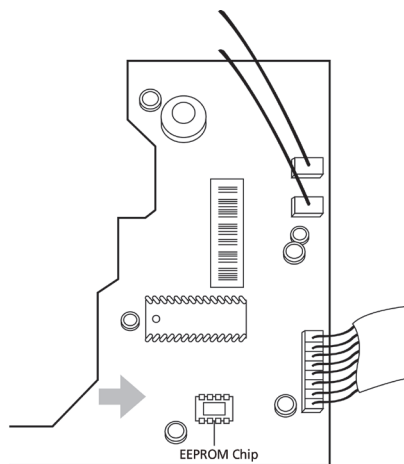

**Note:** This pictures are only for reference, actual appearance may vary.

## TS01-ODU: Outdoor EEPROM parameter error or Compressor driven chip EEPROM parameter error diagnosis and solution

**Description:** Outdoor PCB main chip does not receive feedback from EEPROM chip or compressor driven chip.

**Recommended parts to prepare:**

- Outdoor PCB

**Troubleshooting and repair:**

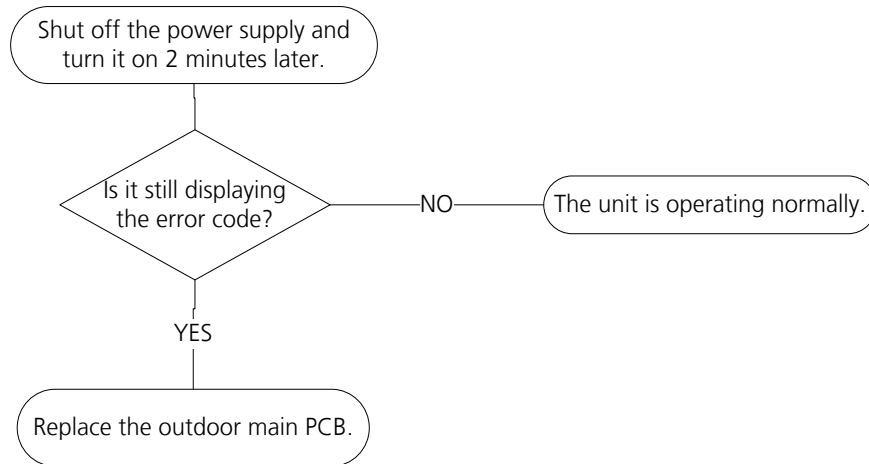

**Remarks:**

**EEPROM:** A read-only memory whose contents can be erased and reprogrammed using a pulsed voltage.

The location of the EEPROM chip on the outdoor PCB is shown in the following image:

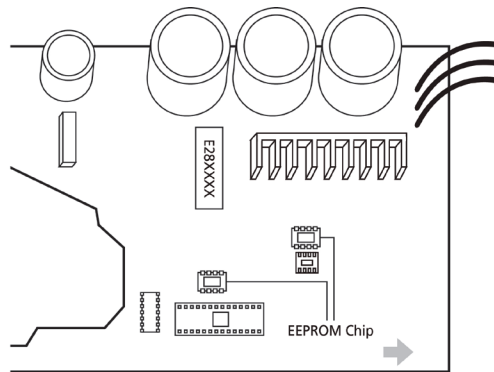

**Note:** For certain models, outdoor PCB could not be removed separately. In this case, the outdoor electric control box should be replaced as a whole. This pictures are only for reference, actual appearance may vary.





### Remarks:

- Use a multimeter to test the DC voltage between 2 port(or S or L2 port) and 3 port(or N or S port) of outdoor unit. The red pin of multimeter connects with 2 port(or S or L2 port) while the black pin is for 3 port(or N or S port).
- When AC is normal running, the voltage is moving alternately as positive values and negative values
- If the outdoor unit has malfunction, the voltage has always been the positive value.
- While if the indoor unit has malfunction, the voltage has always been a certain value.

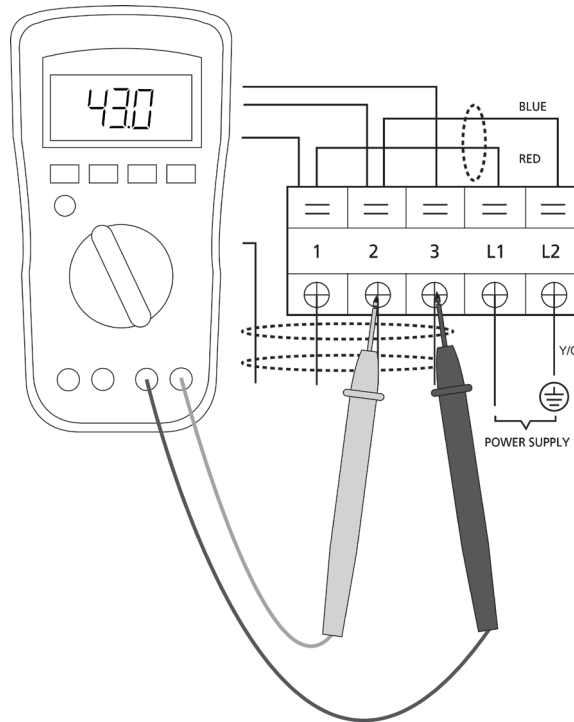

**S and N  
or  
L2 and S  
or  
2 and 3**

- Use a multimeter to test the resistance of the reactor which does not connect with capacitor.
- The normal value should be around zero ohm. Otherwise, the reactor must have malfunction.

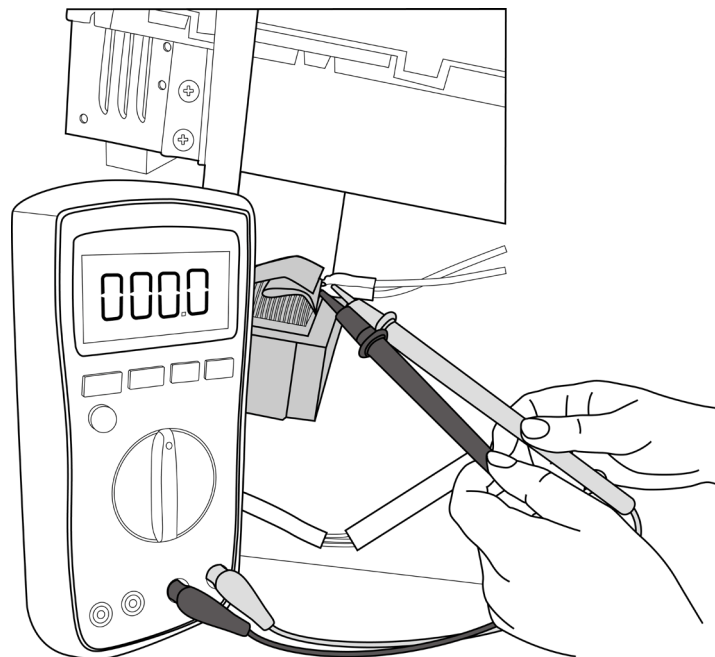

**Note:** The picture and the value are only for reference, actual condition and specific value may vary.

---

### TS03: Zero crossing detection error diagnosis and solution

**Description:** When PCB does not receive zero crossing signal feedback for 4 minutes or the zero crossing signal time interval is abnormal.

**Recommended parts to prepare:**

- Connection wires
- Indoor main PCB

**Troubleshooting and repair:**

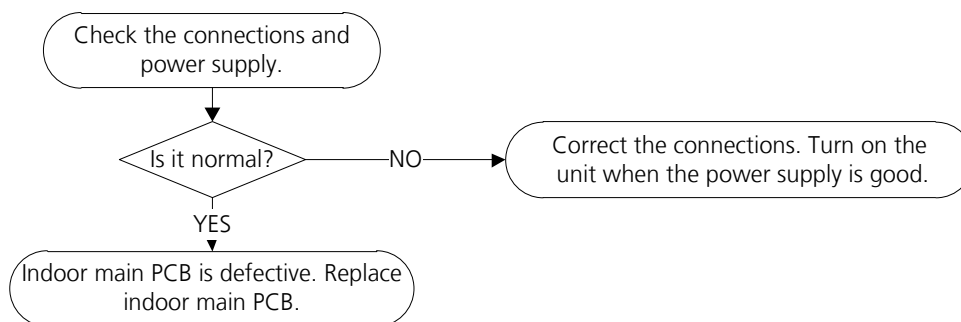

## TS04-L-IDU: The Indoor fan speed is operating outside of normal range diagnosis and solution)

**Description:** When indoor fan speed keeps too low or too high for a certain time, the LED displays the failure code and the AC turns off.

### Recommended parts to prepare:

- Connection wires
- Fan assembly
- Fan motor
- Indoor main PCB

### Troubleshooting and repair:

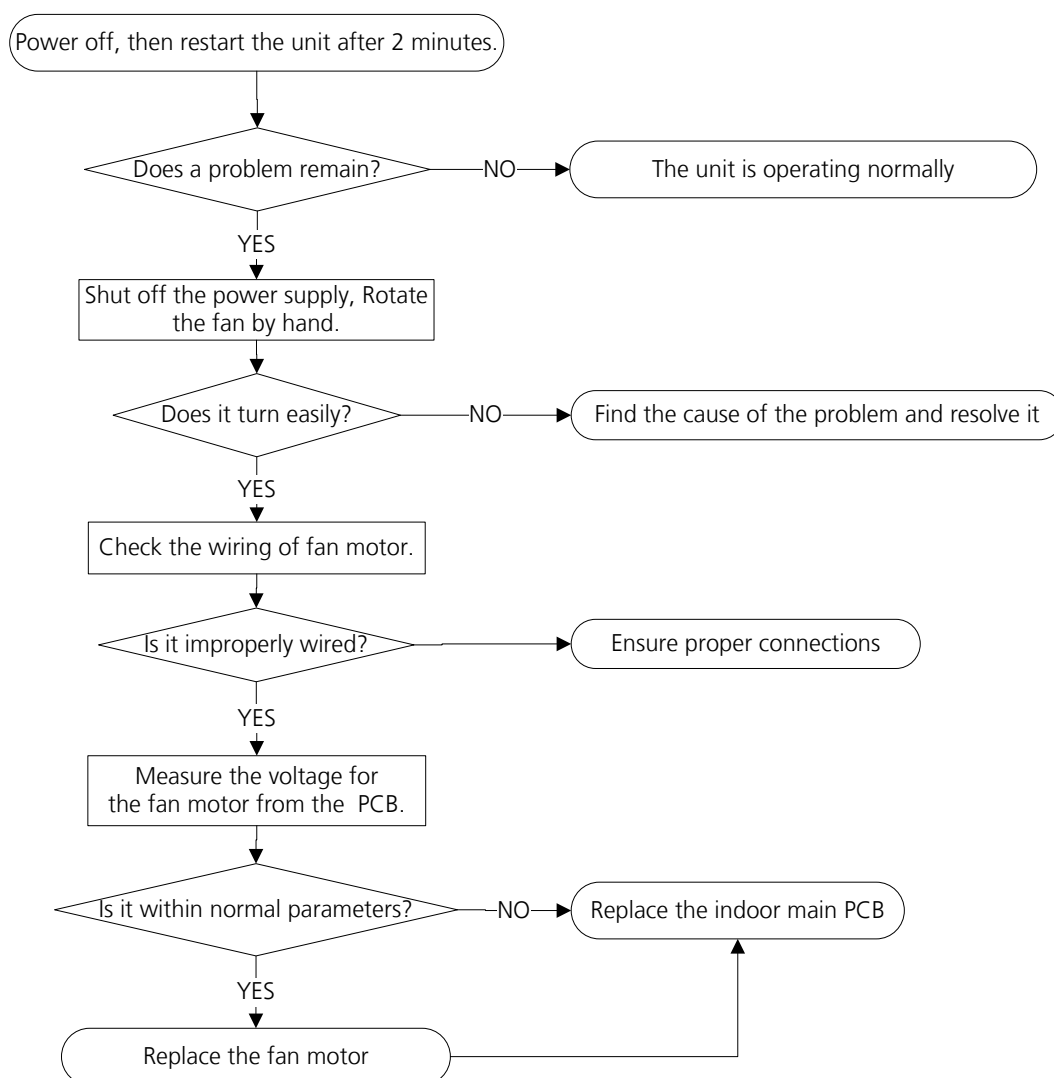

## Index:

### 1. DC Fan Motor(control chip is in fan motor)

Power on and when the unit is in standby, measure the voltage of pin1-pin3, pin4-pin3 in fan motor connector. If the value of the voltage is not in the range showing in below table, the PCB must has problems and need to be replaced.

- DC motor voltage input and output:

No.	Color	Signal	Voltage
1	Red	Vs/Vm	192V~380V
2	---	---	---
3	Black	GND	0V
4	White	Vcc	13.5-16.5V
5	Yellow	Vsp	0~6.5V
6	Blue	FG	13.5-16.5V

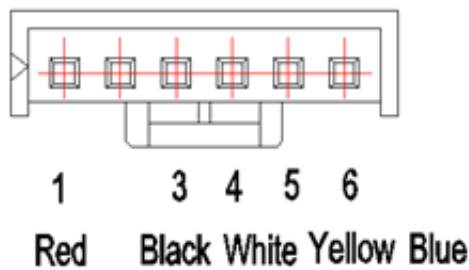

### 2. Indoor AC Fan Motor

Power on and set the unit running in fan mode at high fan speed. After running for 15 seconds, measure the voltage of pin1 and pin2. If the value of the voltage is less than 100V(208~240V power supply) or 50V (115V power supply), the PCB must has problems and need to be replaced.

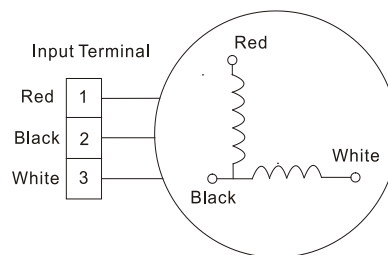

## TS04-ODU: The outdoor fan speed is operating outside of normal range diagnosis and solution)

**Description:** When outdoor fan speed keeps too low or too high for a certain time, the LED displays the failure code and the AC turns off.

### Recommended parts to prepare:

- Connection wires
- Fan assembly
- Fan motor
- Outdoor main PCB

### Troubleshooting and repair:

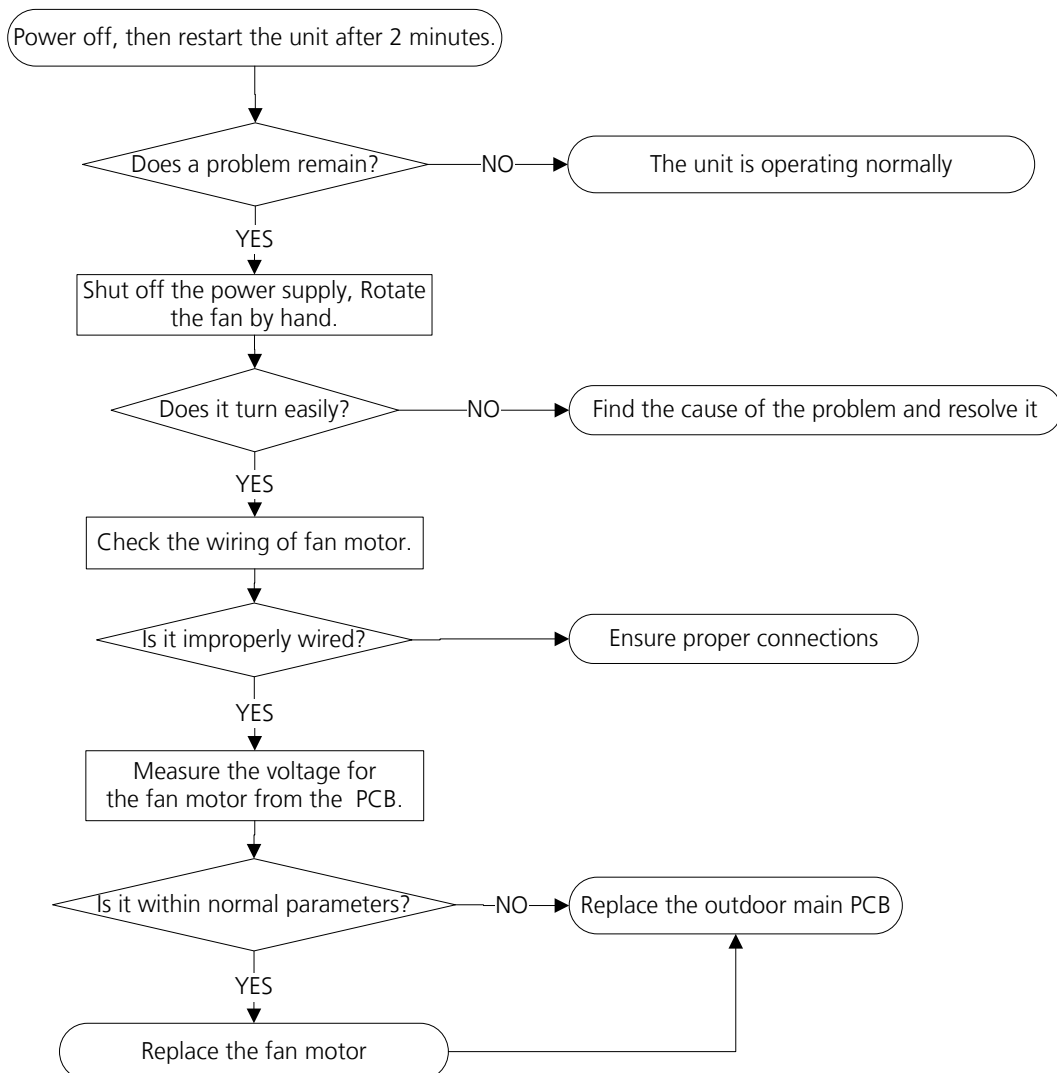

**Index:**

**1. Outdoor DC Fan Motor (control chip is in outdoor PCB)**

Release the UVW connector. Measure the resistance of U-V, U-W, V-W. If the resistance is not equal to each other, the fan motor must have problems and need to be replaced. otherwise the PCB must have problems and need to be replaced.

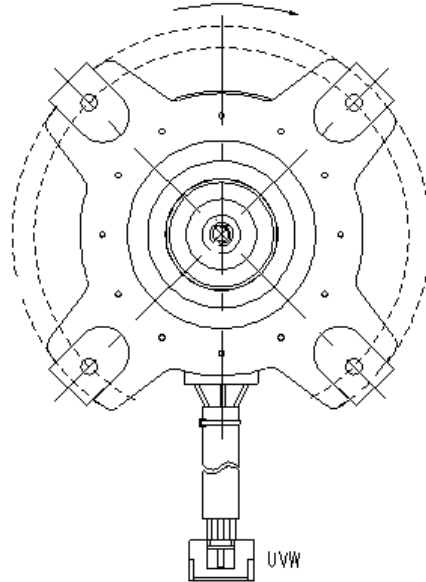

**2. Outdoor DC Fan Motor (DC motor that control chip on the PCB)**

1)Release the UVW connector. Measure the resistance of U-V, U-W, V-W. If the resistance is not equal to each other, the fan motor must have problems and need to be replaced. Otherwise, go to step 2).

2)Power on and when the unit is in standby, measure the voltage of pin4-5 in feedback signal connector. If the value is not 5V, change the PCB. Otherwise, go to step 3).

3)Rotate the fan by hand, measure the voltage of pin1-5, pin 2-5 and pin 3-5 in feedback signal connector. If any voltage is not positive voltage fluctuation, the fan motor must have problems and need to be replaced.

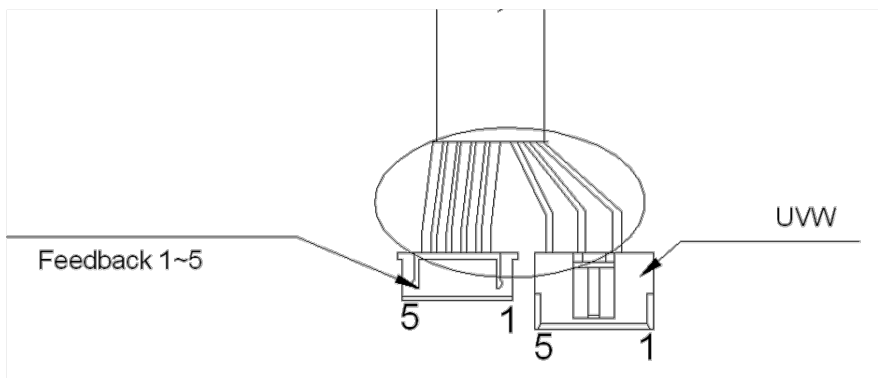

NO.	1	2	3	4	5
Color	Orange	Grey	White	Pink	Black
Signal	Hu	Hv	Hw	Vcc	GND

Color	Red	Blue	Yellow
Signal	W	V	U

## TS05-IDU: Open circuit or short circuit of indoor temperature sensor(T1, T2) diagnosis and solution

**Description:** If the sampling voltage is lower than 0.06V or higher than 4.94V, the LED displays the failure code.

### Recommended parts to prepare:

- Connection wires
- Sensors
- Indoor main PCB

### Troubleshooting and repair:

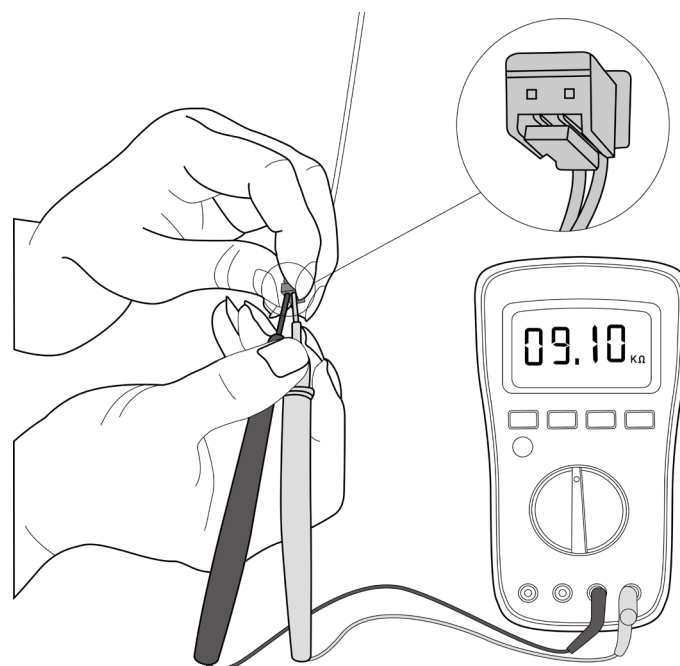
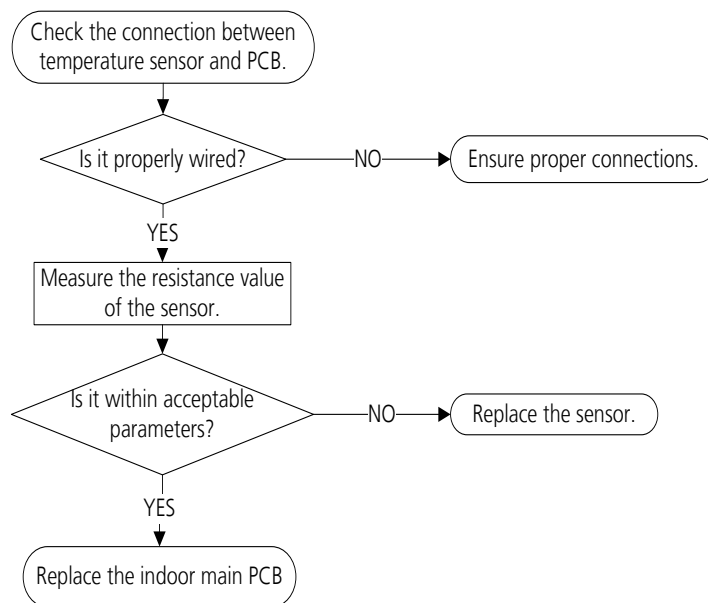

**Note:** The picture and the value are only for reference, actual condition and specific value may vary.



## TS05-ODU: Open circuit or short circuit of outdoor temperature sensor(T3, T4, TP, T2B,TH) diagnosis and solution

**Description:** If the sampling voltage is lower than 0.06V or higher than 4.94V, the LED displays the failure code.

### Recommended parts to prepare:

- Connection wires
- Sensors
- Outdoor main PCB

### Troubleshooting and repair:

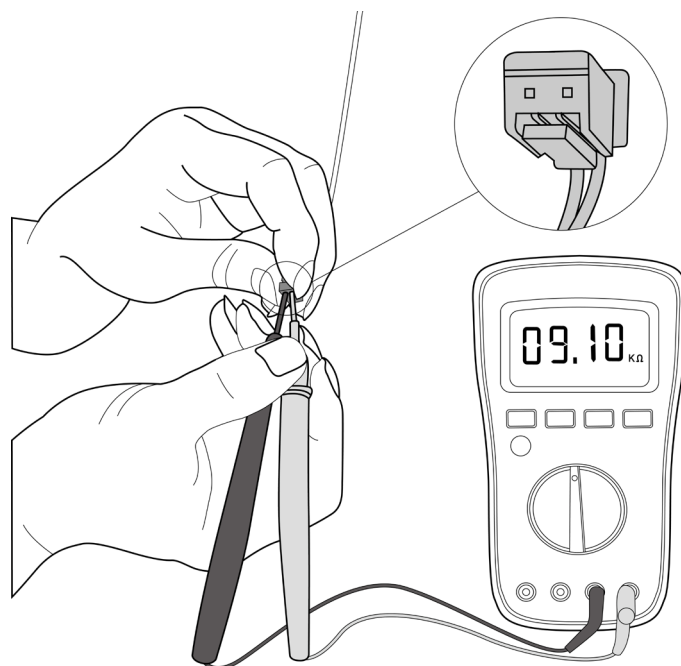
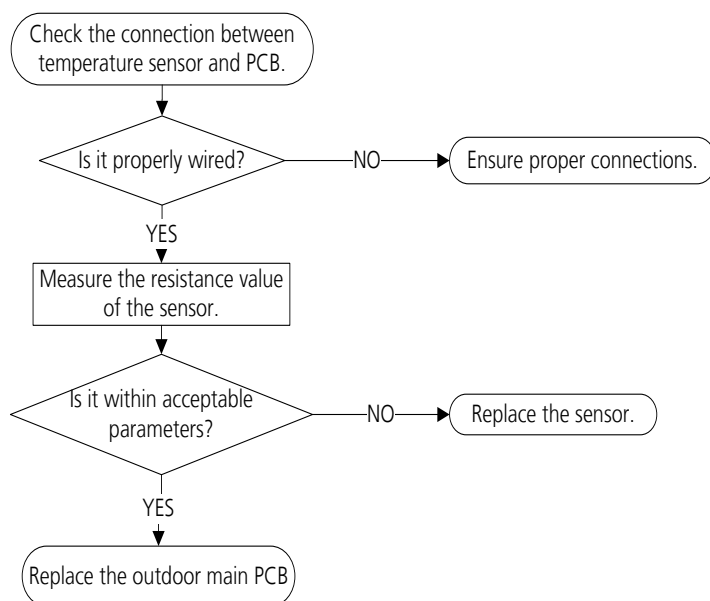

**Note:** For certain models, outdoor PCB could not be removed separately. In this case, the outdoor electric control box should be replaced as a whole. For certain models, outdoor unit uses combination sensor, T3,T4 and TP are the same of sensor. This picture and the value are only for reference, actual appearance and value may vary.

---

## **TS08-L-INV: Current overload protection diagnosis and solution**

**Description:** An abnormal current rise is detected by checking the specified current detection circuit.

### **Recommended parts to prepare:**

- Connection wires
- Rectifier
- PFC circuit or reactor
- Blocked refrigeration piping system
- Pressure switch
- Outdoor fan
- IPM module board
- Outdoor PCB

### **Troubleshooting and repair:**



**Note:** For certain models, outdoor PCB could not be removed separately. In this case, the outdoor electric control box should be replaced as a whole.

## Index:

### 1. Normal voltage of P and N

208-240V(1-phase,3-phase)		380-415V(3-phase)	
In standby			
around 310VDC		around 530VDC	
In operation			
With passive PFC module	With partial active PFC module	With fully active PFC module	/
>200VDC	>310VDC	>370VDC	>450VDC

### 2.Reactor Check

Measure the resistance and voltage (to ground) of the reactor. The normal resistance should be around 0.1 ohm. Otherwise, the reactor must have malfunction.

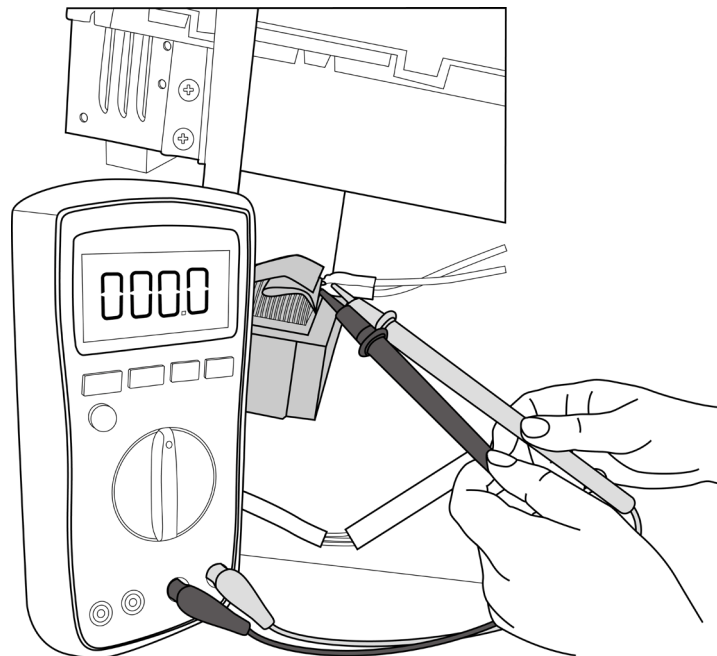

**Note:** The picture and the value are only for reference, actual condition and specific value may vary.

---

## TS09-L: IPM malfunction or IGBT over-strong current protection or Inverter compressor drive error diagnosis and solution

**Description:** When the voltage signal the IPM sends to the compressor drive chip is abnormal, the LED displays the failure code and the AC turns off.

Or an abnormal inverter compressor drive is detected by a special detection circuit, including communication signal detection, voltage detection, compressor rotation speed signal detection and so on.

### Recommended parts to prepare:

- Connection wires
- IPM module board
- Outdoor fan assembly
- Compressor
- Outdoor PCB
- High-voltage components
- PFC circuit or reactor

### Troubleshooting and repair:

First, test the resistance between every two ports of U, V, the W of the IPM and P, N. If any of the results is 0 or close to 0, the IPM is defective. If not, follow the following procedure:

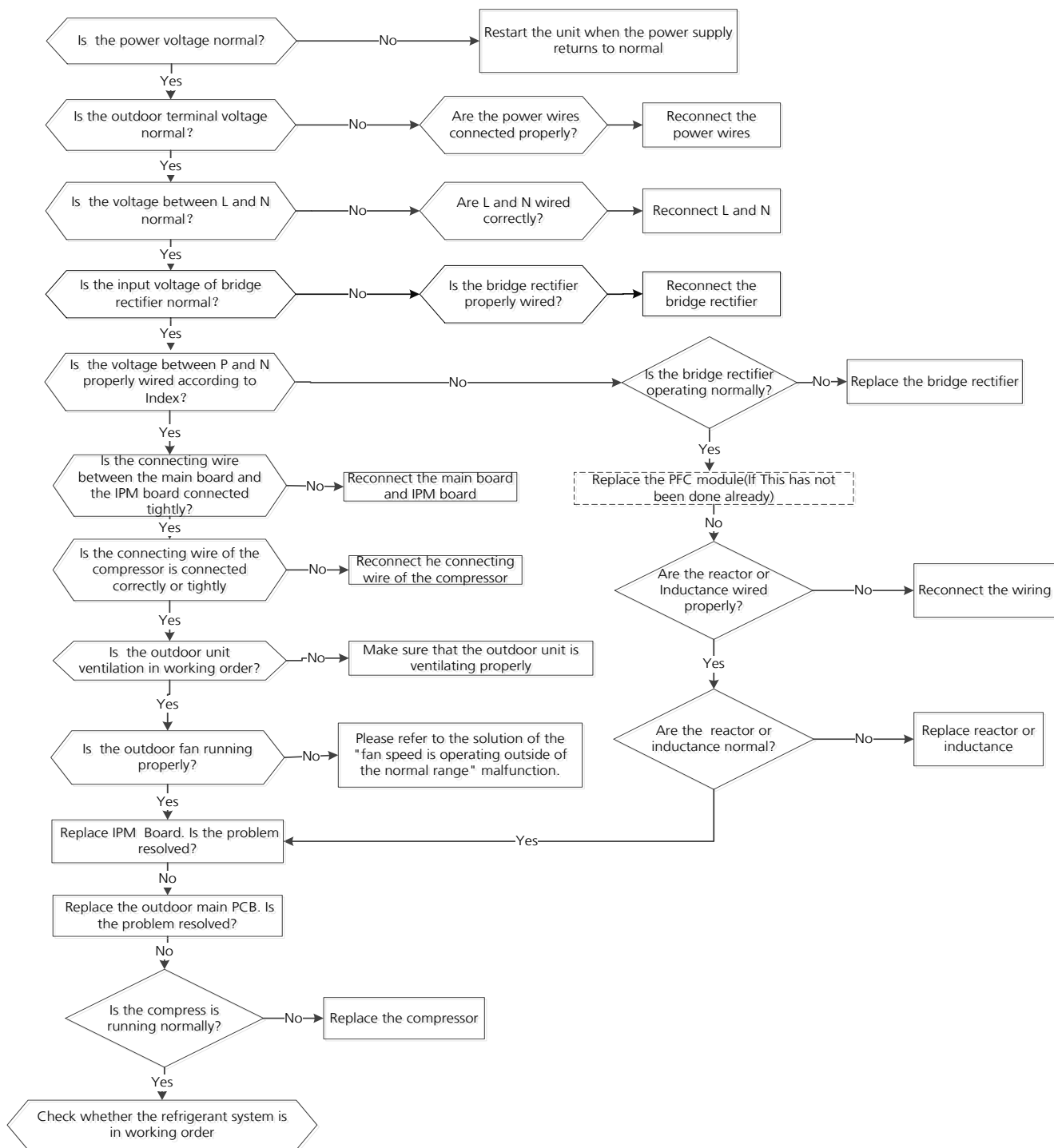

**Note:** For certain models, outdoor PCB could not be removed separately. In this case, the outdoor electric control box should be replaced as a whole.

Index:

1. IPM Continuity Check

**! WARNING**

**Electricity remains in capacitors even when the power supply is off.  
Ensure the capacitors are fully discharged before troubleshooting.**

1. Turn off outdoor unit and disconnect power supply.
2. Discharge electrolytic capacitors and ensure all energy-storage unit has been discharged.
3. Disassemble outdoor PCB or disassemble IPM board.
4. Measure the resistance value between P and U(V, W, N); U(V, W) and N.

Digital tester		Resistance value	Digital tester		Resistance value
(+)Red	(-)Black		(+)Red	(-)Black	
P	N	∞ (Several MΩ)	U	N	∞ (Several MΩ)
	U				
	V				
	W				
			-		

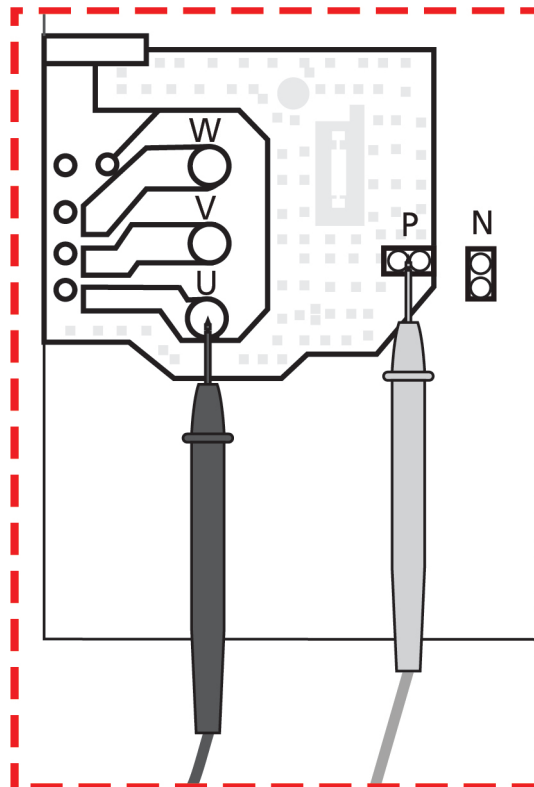

## 2. Normal voltage of P and N

208-240V(1-phase,3-phase)		380-415V(3-phase)	
In standby		around 310VDC	
around 310VDC		around 530VDC	
In operation			
With passive PFC module	With partial active PFC module	With fully active PFC module	/
>200VDC	>310VDC	>370VDC	>450VDC

## 3. Reactor Check

Measure the resistance and voltage (to ground) of the reactor. The normal resistance should be around 0.1 ohm. Otherwise, the reactor must have malfunction.

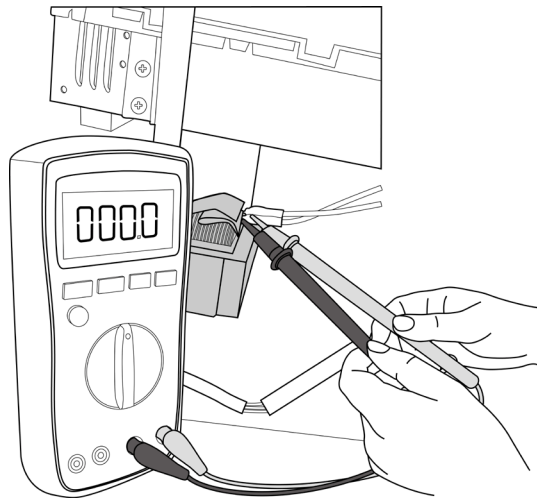

## 4. Compressor check

Disconnect the compressor and check the resistance between U-V, V-W and U-W, and all 3 values should be equal. If not, the compressor is faulty and should be replaced.

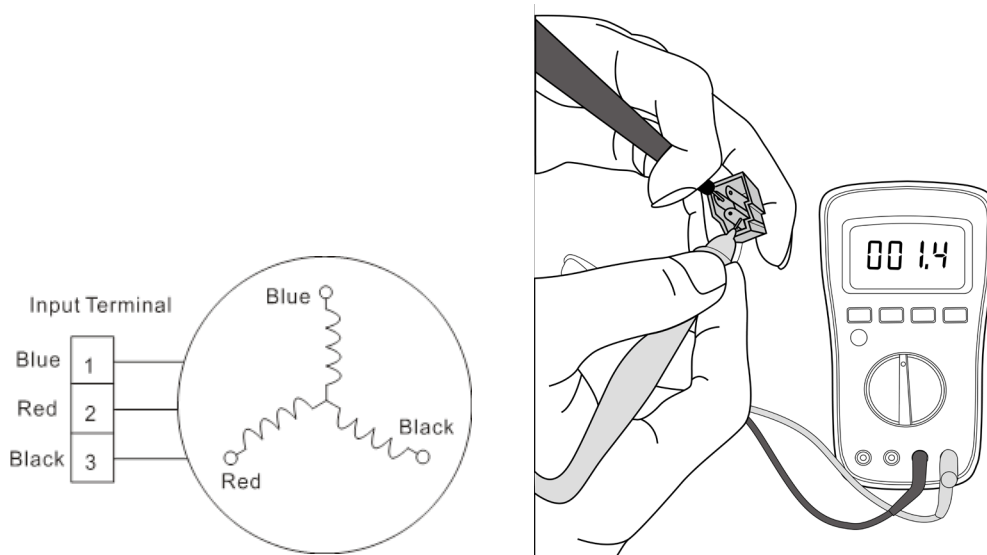

**Note:** The picture and the value are only for reference, actual condition and specific value may vary.



---

## **TS10-L: Over voltage or too low voltage protection diagnosis and solution**

**Description:** Abnormal increases or decreases in voltage are detected by checking the specified voltage detection circuit.

**Recommended parts to prepare:**

- Power supply wires
- IPM module board
- PCB
- Reactor

**Troubleshooting and repair:**

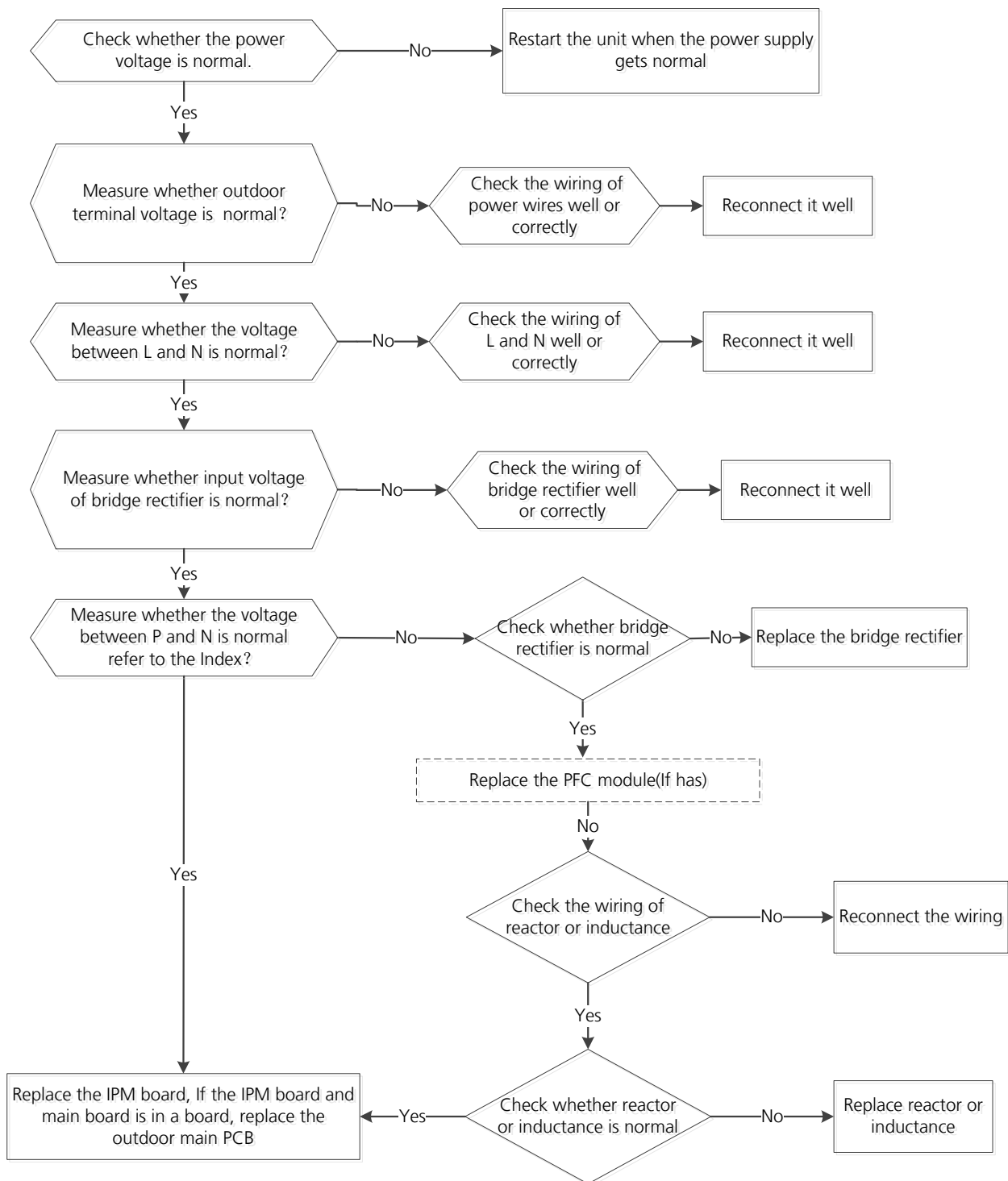

**Note:** For certain models, outdoor PCB could not be removed separately. In this case, the outdoor electric control box should be replaced as a whole.

## Index:

### 1. Normal voltage of P and N

208-240V(1-phase,3-phase)		380-415V(3-phase)	
In standby			
around 310VDC		around 530VDC	
In operation			
With passive PFC module	With partial active PFC module	With fully active PFC module	/
>200VDC	>310VDC	>370VDC	>450VDC

### 2. Reactor Check

Measure the resistance and voltage (to ground) of the reactor. The normal resistance should be around 0.1 ohm. Otherwise, the reactor must have malfunction.

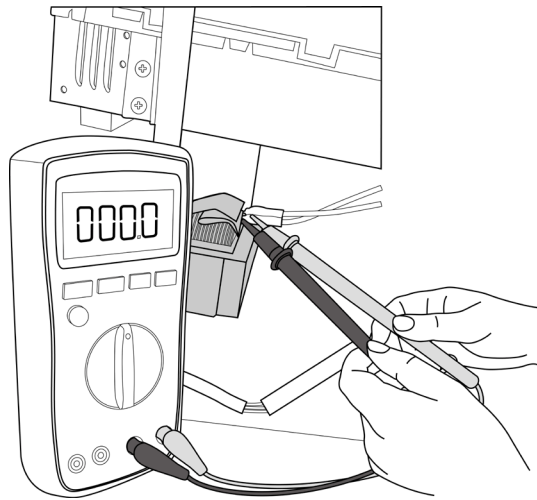

**Note:** The picture and the value are only for reference, actual condition and specific value may vary.

## TS11-L: Top temperature protection of compressor diagnosis and solution

**Description:** If the sampling voltage is not 5V, the LED will display the failure.

### Recommended parts to prepare:

- Connection wires
- Outdoor PCB
- Over load protector

### Troubleshooting and repair:

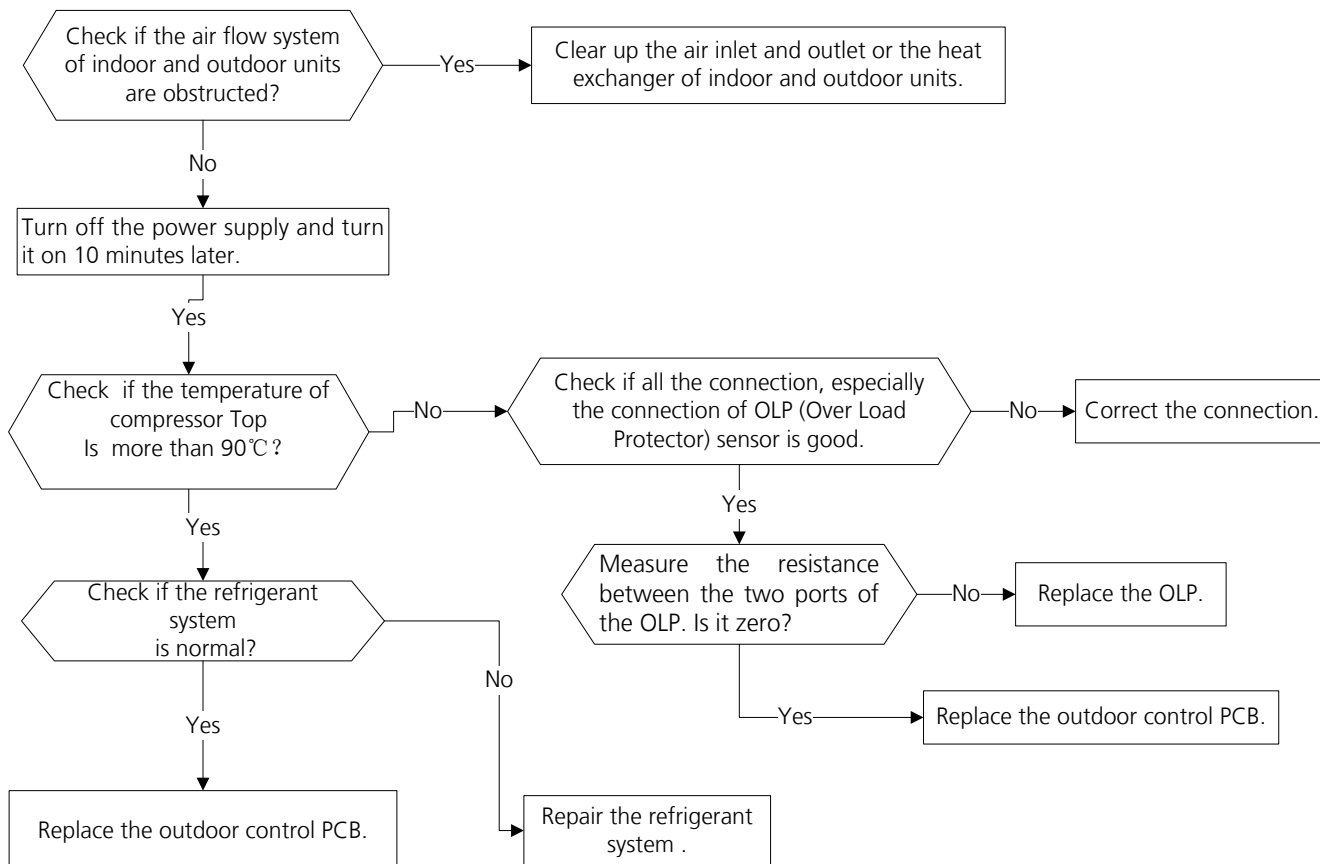

---

**TS14: Indoor units mode conflict (match with multi outdoor unit)**

**Description:** The indoor units cannot work cooling mode and heating at same time. Heating mode has a priority.

- Suppose Indoor unit A working in cooling mode or fan mode, and indoor unit B is set to heating mode, then A will change to off and B will work in heating mode.
- Suppose Indoor unit A working in heating mode, and indoor unit B is set to cooling mode or fan mode, then B will change to stand by and A will be no change.

	Cooling mode	Heating Mode	Fan	Off
Cooling mode	No	Yes	No	No
Heating Mode	Yes	No	Yes	No
Fan	No	Yes	No	No
Off	No	No	No	No

**Note:**

**No:** No mode conflict

**Yes:** Mode conflict

## TS15: Water-Level Alarm Malfunction Diagnosis and Solution

**Description:** If the sampling voltage is not 5V, the LED displays the failure code.

### Recommended parts to prepare:

- Connection wires
- Water-level switch
- Water pump
- Indoor PCB

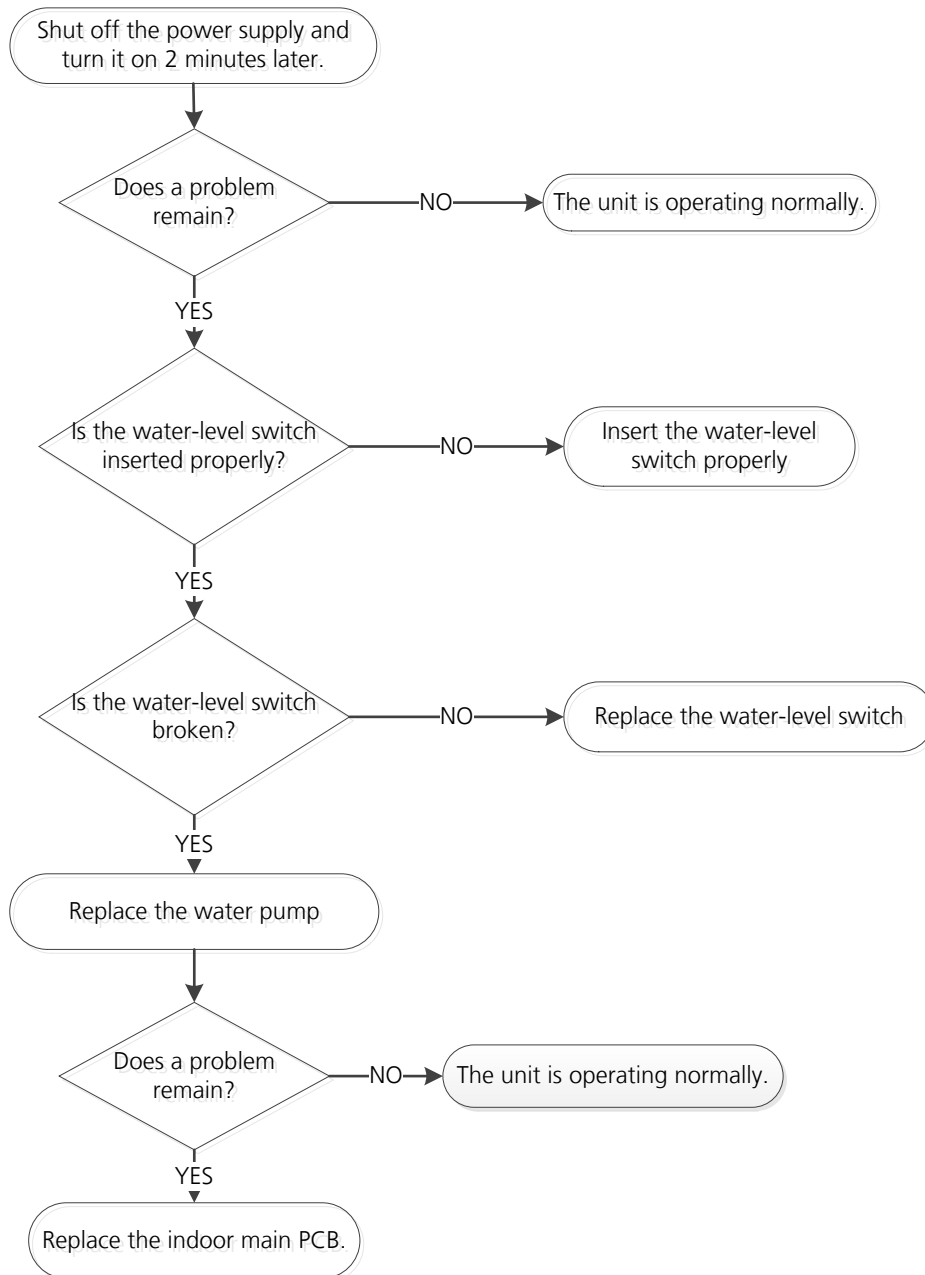

---

## TS23: Communication error between indoor two chips diagnosis and solution

**Description:** Indoor PCB main chip does not receive feedback from another chip.

**Recommended parts to prepare:**

- Indoor PCB

**Troubleshooting and repair:**

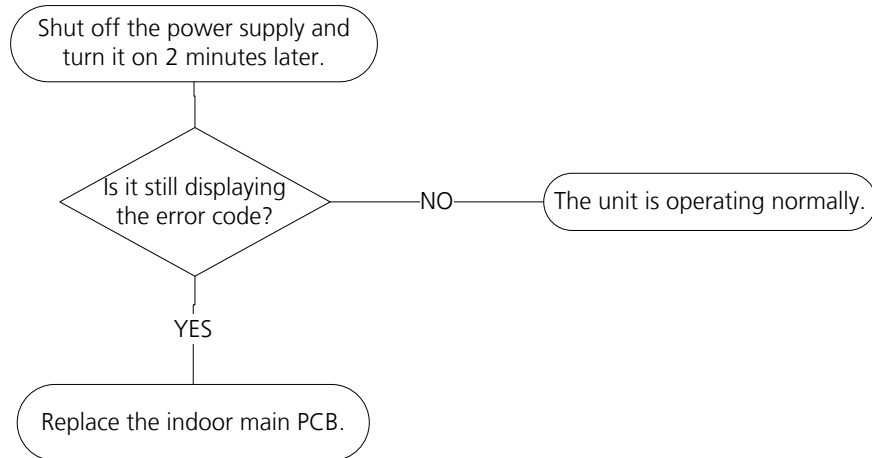

---

## TS13-INV: Low pressure protection diagnosis and solution

**Description:** Outdoor pressure switch cut off the system because low pressure is lower than 0.13 MPa, the LED displays the failure code.

### Recommended parts to prepare:

- Connection wires
- Outdoor PCB
- Low pressure protector
- Refrigerant

### Troubleshooting and repair:



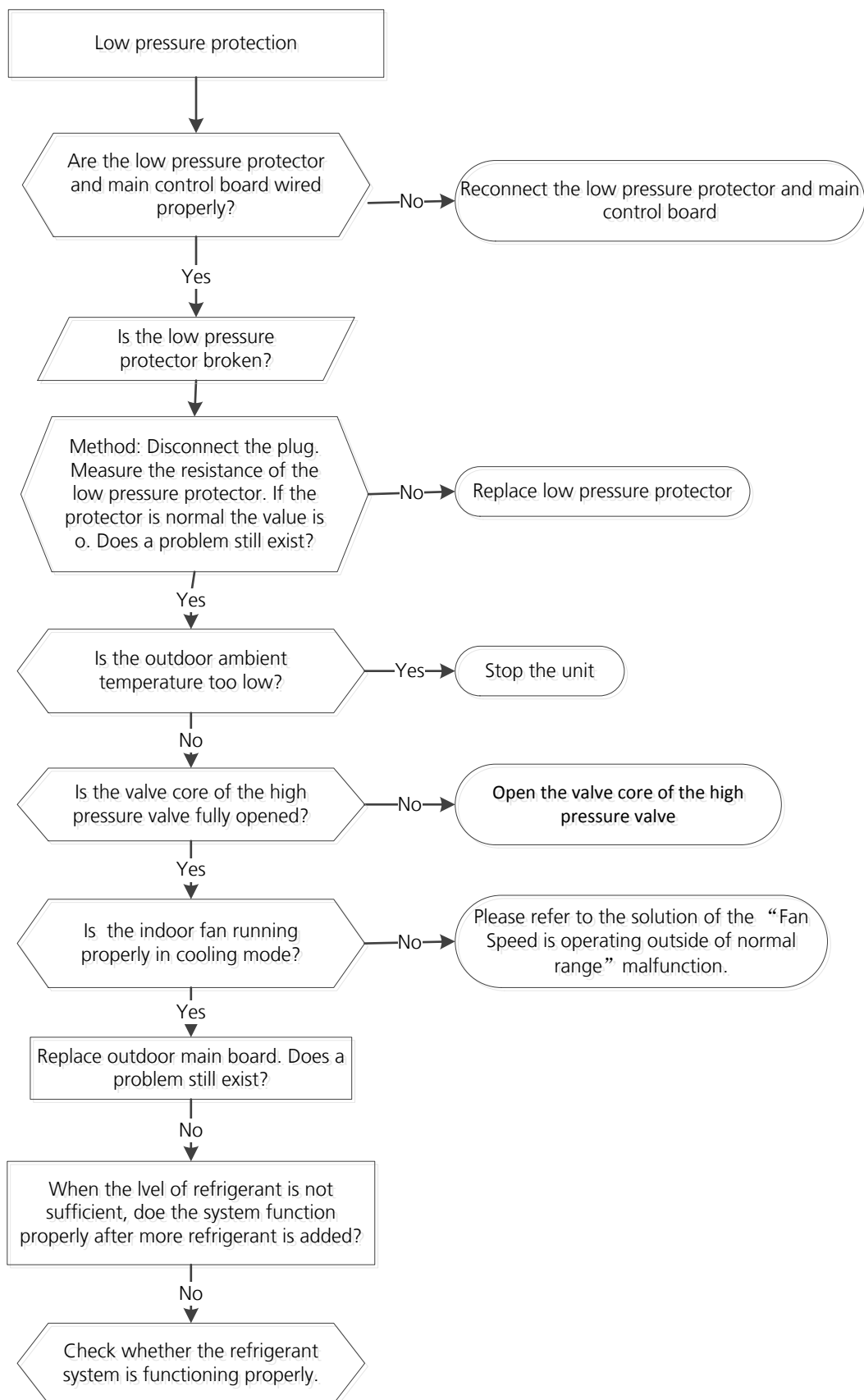

**Note:** For certain models, outdoor PCB could not be removed separately. In this case, the outdoor electric control box should be replaced as a whole.

---

## TS28: High pressure protection diagnosis and solution

**Description:** Outdoor pressure switch cut off the system because high pressure is higher than 4.4 MPa

**Recommended parts to prepare:**

- Connection wires
- Pressure switch
- Outdoor fan
- Outdoor main PCB

**Troubleshooting and repair:**

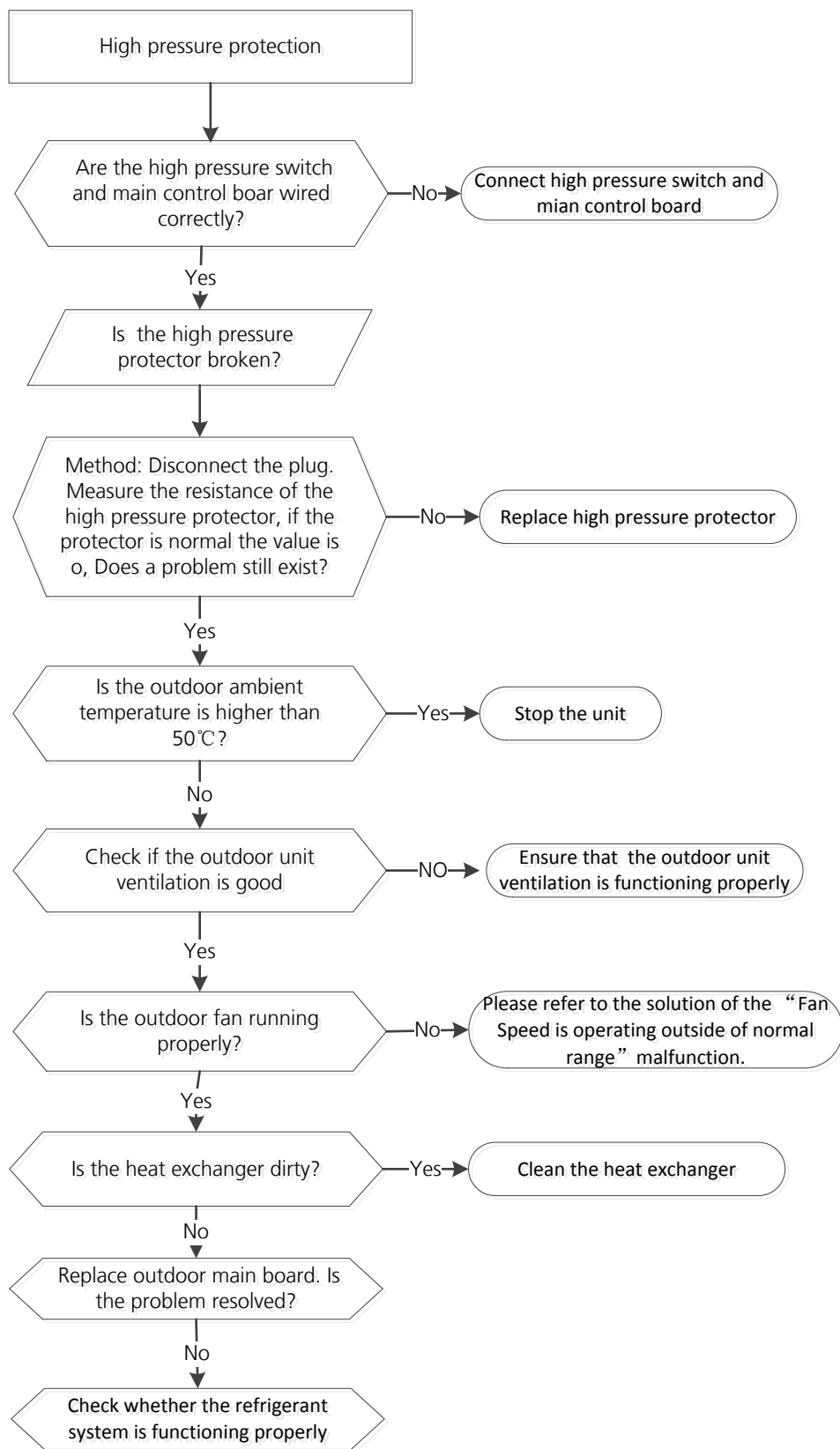

## TS31: Communication error between outdoor main PCB and IPM board diagnosis and solution

**Description:** The main PCB cannot detect the IPM board.

### Recommended parts to prepare:

- Connection wires
- IPM board
- Outdoor main PCB
- Electric control box

### Troubleshooting and repair:

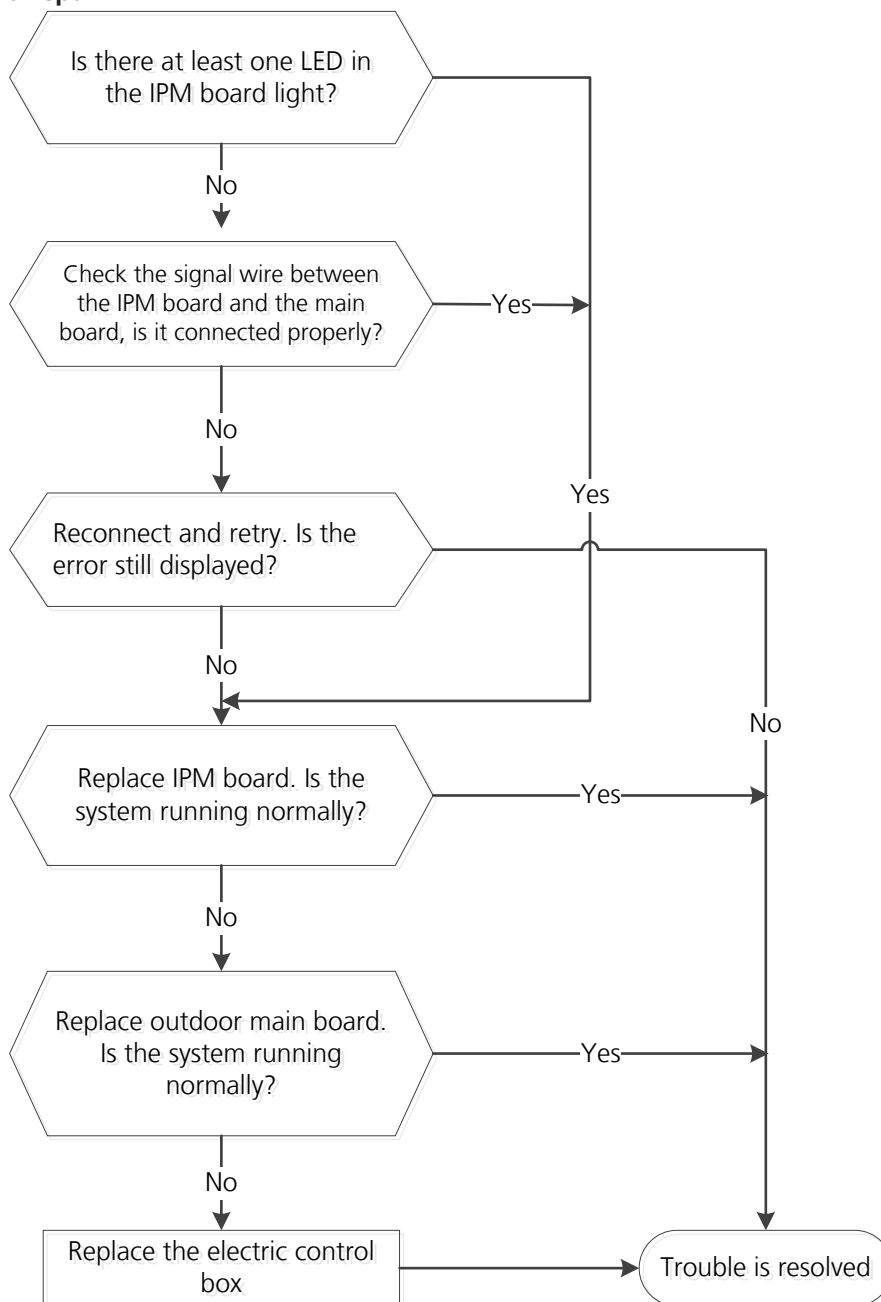

## TS32: Discharge temperature protection of compressor diagnosis and solution

**Description:** If the compressor discharge temperature exceeds a certain level for nine seconds, the compressor ceases operation, the LED displays the failure code

### Recommended parts to prepare:

- Connection wires
- Discharge temperature sensor
- Additional refrigerant
- Outdoor main PCB

### Troubleshooting and repair:

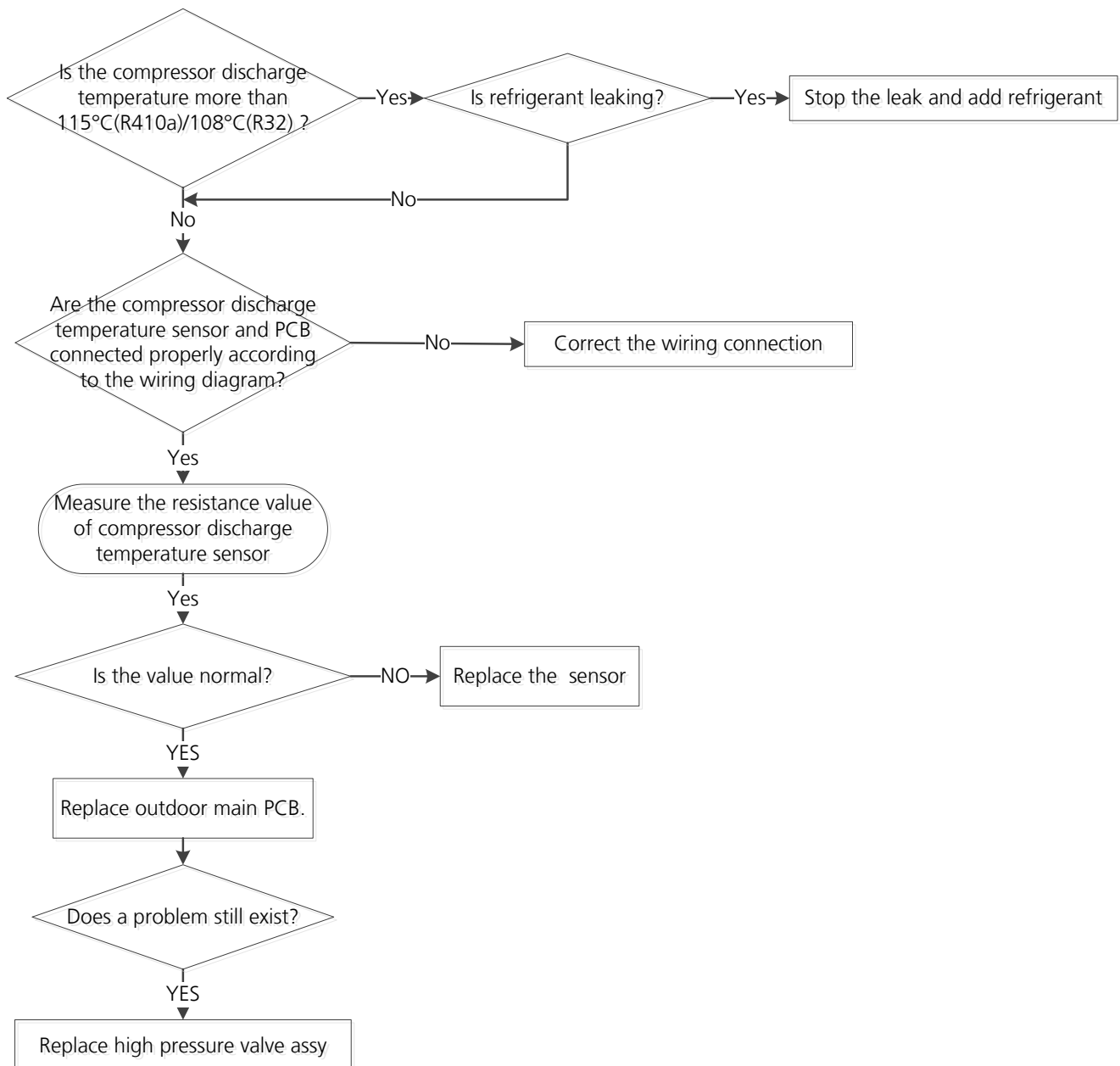

**Note:** For certain models, outdoor unit uses combination sensor, T3,T4 and TP are the same of sensor. This picture and the value are only for reference, actual appearance and value may vary.

## TS27-INV: High temperature protection of condenser diagnosis and solution

**Description:** When the outdoor pipe temperature is more than 65°C, the unit stops. It starts again only when the outdoor pipe temperature is less than 52°C.

### Recommended parts to prepare:

- Connection wires
- Condenser temperature sensor
- Outdoor fan
- Outdoor main PCB
- Refrigerant

### Troubleshooting and repair:



## TS30: PFC module protection diagnosis and solution

**Description:** When the voltage signal that IPM send to compressor drive chip is abnormal, the LED displays the failure code and the AC turns off.

### Recommended parts to prepare:

- Connection wires
- Inductance
- Outdoor main PCB
- PFC module

### Troubleshooting and repair:

At first test the resistance between every two ports of U, V, W of IPM and P, N. If any result of them is 0 or close to 0, the IPM is defective. Otherwise, please follow the procedure below:

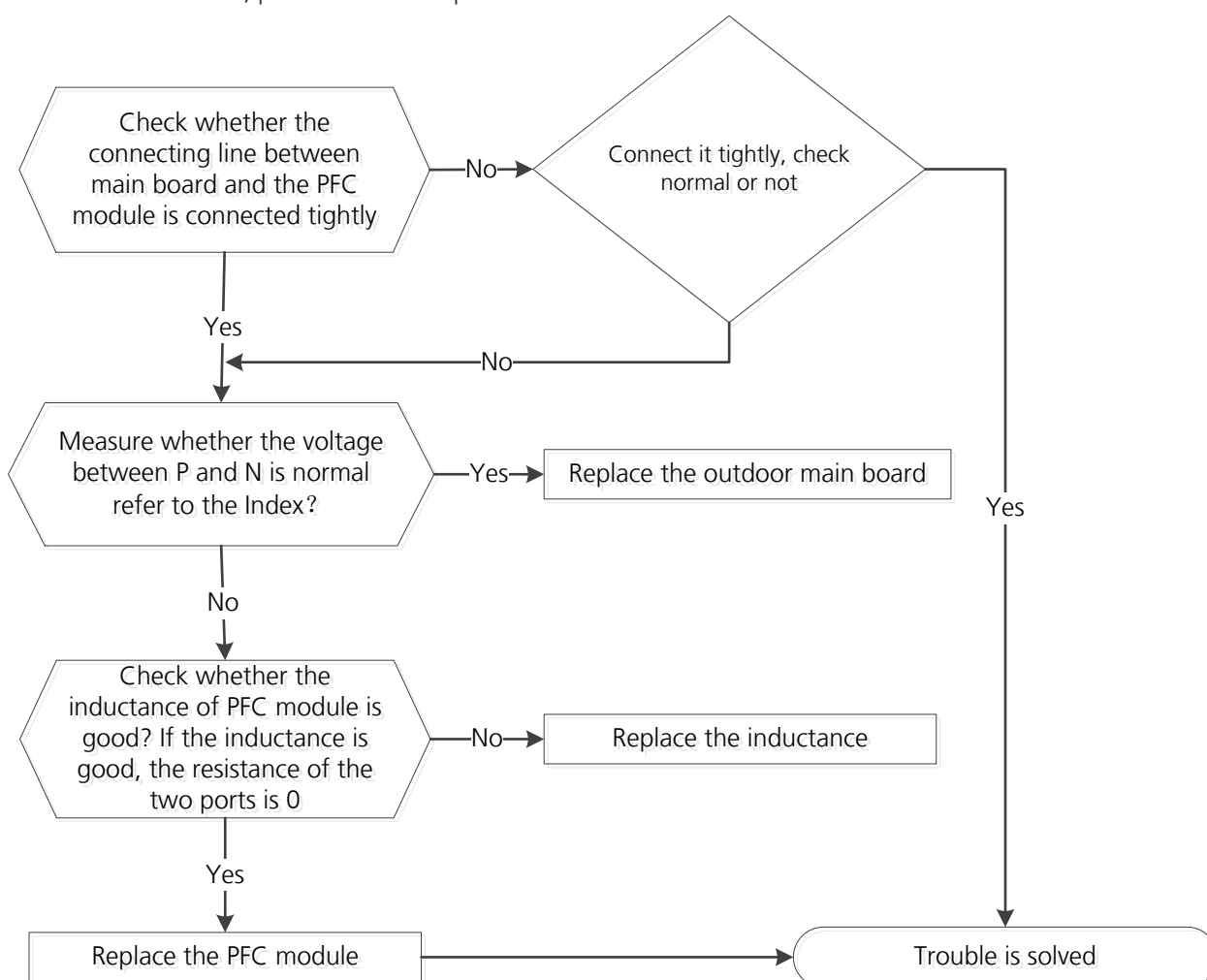

## Index:

### 1. Normal voltage of P and N

208-240V(1-phase,3-phase)		380-415V(3-phase)	
In standby			
around 310VDC		around 530VDC	
In operation			
With passive PFC module	With partial active PFC module	With fully active PFC module	/
>200VDC	>310VDC	>370VDC	>450VDC

### 2. Reactor Check

Measure the resistance and voltage (to ground) of the reactor. The normal resistance should be around 0.1 ohm. Otherwise, the reactor must have malfunction.

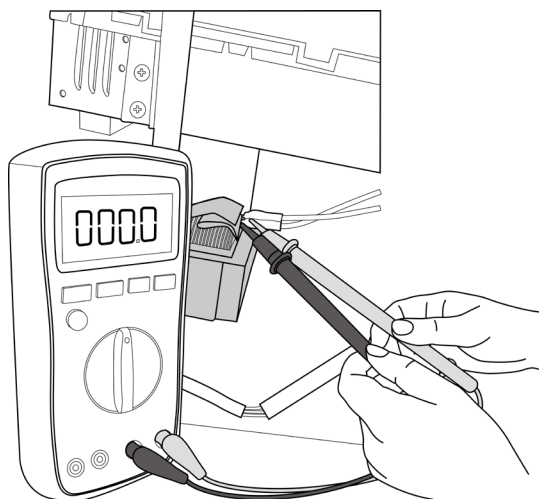

**Note:** The picture and the value are only for reference, actual condition and specific value may vary.



## 9. Check Procedures

### 9.1 Temperature Sensor Check

#### WARNING

**Be sure to turn off all power supplies or disconnect all wires to avoid electric shock. Operate after compressor and coil have returned to normal temperature in case of injury.**

1. Disconnect the temperature sensor from PCB (Refer to Chapter 5&6. Indoor&Outdoor Unit Disassembly).
2. Measure the resistance value of the sensor using a multi-meter.
3. Check corresponding temperature sensor resistance value table (Refer to Chapter 8. Appendix).

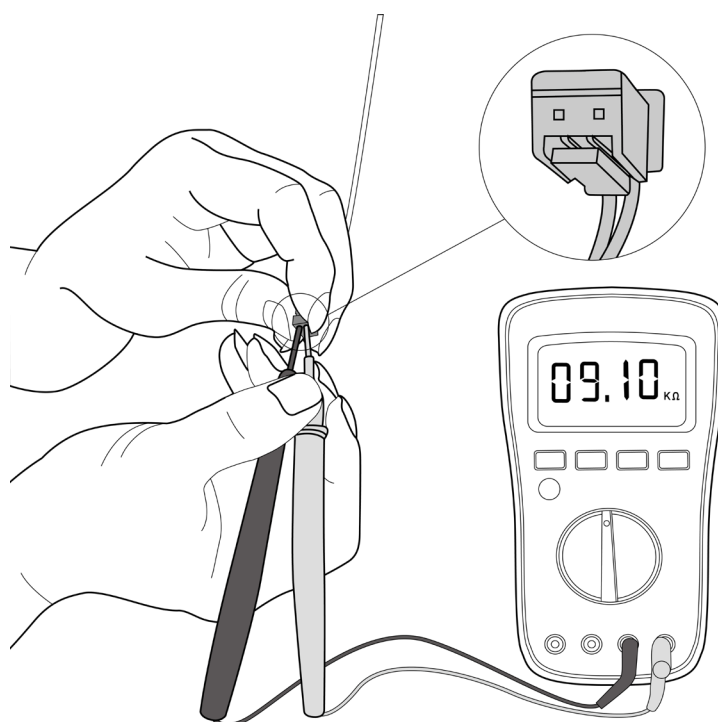

**Note:** The picture and the value are only for reference, actual condition and specific value may vary.

## 9.2 Compressor Check

1. Disconnect the compressor power cord from outdoor PCB (Refer to Chapter 6. Outdoor Unit Disassembly)).
2. Measure the resistance value of each winding using a multi-meter.
3. Check the resistance value of each winding in the following table.

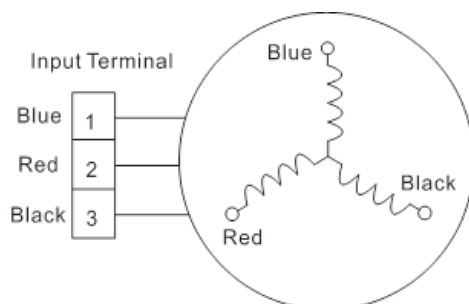

Resistance Value	ATM150D23UFZ	ATF235D22UMT	ATF310D43UMT	ATQ360D1UMU
Blue-Red	1.72Ω	0.75Ω	0.65Ω	0.37 Ω
Blue-Black				
Red-Black				

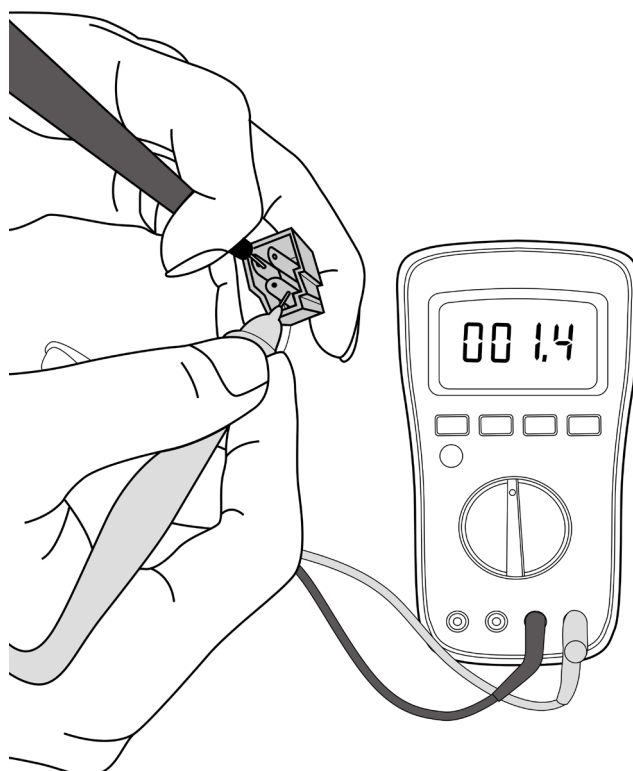

**Note:** The picture and the value are only for reference, actual condition and specific value may vary.

### 9.3 IPM Continuity Check

#### **⚠ WARNING**

**Electricity remains in capacitors even when the power supply is off. Ensure the capacitors are fully discharged before troubleshooting.**

1. Turn off outdoor unit and disconnect power supply.
2. Discharge electrolytic capacitors and ensure all energy-storage unit has been discharged.
3. Disassemble outdoor PCB or disassemble IPM board.
4. Measure the resistance value between P and U(V, W, N); U(V, W) and N.

Digital tester		Resistance value	Digital tester		Resistance value
(+)Red	(-)Black		(+)Red	(-)Black	
P	N	∞ (Several MΩ)	U	N	∞ (Several MΩ)
	U		V		
	V		W		
	W		-		

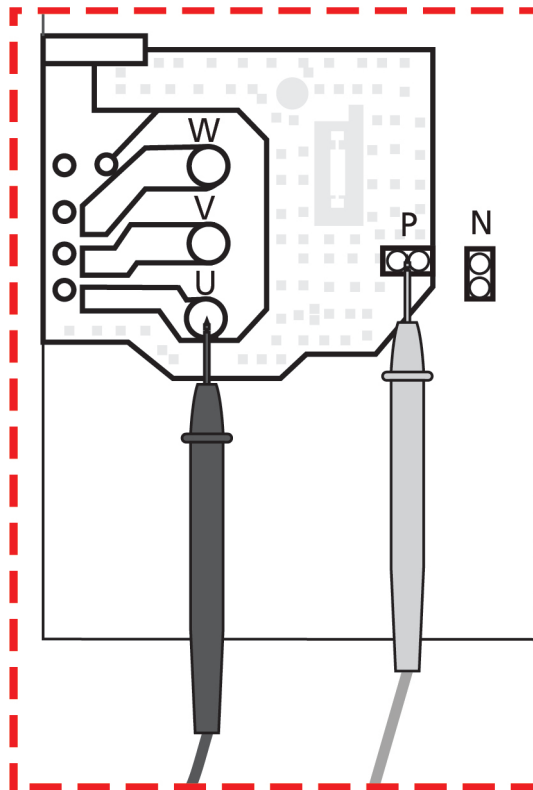

**Note:** The picture and the value are only for reference, actual condition and specific value may vary.

---

# Appendix

## Contents

i)	Temperature Sensor Resistance Value Table for T1, T2, T3, and T4 (°C – K) ..	181
ii)	Temperature Sensor Resistance Value Table for TP (°C – K).....	182
iii)	Pressure On Service Port.....	183

**i) Temperature Sensor Resistance Value Table for T1,T2,T3 and T4 (°C – K)**

°C	°F	K Ohm	°C	°F	K Ohm	°C	°F	K Ohm	°C	°F	K Ohm
-20	-4	115.266	20	68	12.6431	60	140	2.35774	100	212	0.62973
-19	-2	108.146	21	70	12.0561	61	142	2.27249	101	214	0.61148
-18	0	101.517	22	72	11.5	62	144	2.19073	102	216	0.59386
-17	1	96.3423	23	73	10.9731	63	145	2.11241	103	217	0.57683
-16	3	89.5865	24	75	10.4736	64	147	2.03732	104	219	0.56038
-15	5	84.219	25	77	10	65	149	1.96532	105	221	0.54448
-14	7	79.311	26	79	9.55074	66	151	1.89627	106	223	0.52912
-13	9	74.536	27	81	9.12445	67	153	1.83003	107	225	0.51426
-12	10	70.1698	28	82	8.71983	68	154	1.76647	108	226	0.49989
-11	12	66.0898	29	84	8.33566	69	156	1.70547	109	228	0.486
-10	14	62.2756	30	86	7.97078	70	158	1.64691	110	230	0.47256
-9	16	58.7079	31	88	7.62411	71	160	1.59068	111	232	0.45957
-8	18	56.3694	32	90	7.29464	72	162	1.53668	112	234	0.44699
-7	19	52.2438	33	91	6.98142	73	163	1.48481	113	235	0.43482
-6	21	49.3161	34	93	6.68355	74	165	1.43498	114	237	0.42304
-5	23	46.5725	35	95	6.40021	75	167	1.38703	115	239	0.41164
-4	25	44	36	97	6.13059	76	169	1.34105	116	241	0.4006
-3	27	41.5878	37	99	5.87359	77	171	1.29078	117	243	0.38991
-2	28	39.8239	38	100	5.62961	78	172	1.25423	118	244	0.37956
-1	30	37.1988	39	102	5.39689	79	174	1.2133	119	246	0.36954
0	32	35.2024	40	104	5.17519	80	176	1.17393	120	248	0.35982
1	34	33.3269	41	106	4.96392	81	178	1.13604	121	250	0.35042
2	36	31.5635	42	108	4.76253	82	180	1.09958	122	252	0.3413
3	37	29.9058	43	109	4.5705	83	181	1.06448	123	253	0.33246
4	39	28.3459	44	111	4.38736	84	183	1.03069	124	255	0.3239
5	41	26.8778	45	113	4.21263	85	185	0.99815	125	257	0.31559
6	43	25.4954	46	115	4.04589	86	187	0.96681	126	259	0.30754
7	45	24.1932	47	117	3.88673	87	189	0.93662	127	261	0.29974
8	46	22.5662	48	118	3.73476	88	190	0.90753	128	262	0.29216
9	48	21.8094	49	120	3.58962	89	192	0.8795	129	264	0.28482
10	50	20.7184	50	122	3.45097	90	194	0.85248	130	266	0.2777
11	52	19.6891	51	124	3.31847	91	196	0.82643	131	268	0.27078
12	54	18.7177	52	126	3.19183	92	198	0.80132	132	270	0.26408
13	55	17.8005	53	127	3.07075	93	199	0.77709	133	271	0.25757
14	57	16.9341	54	129	2.95896	94	201	0.75373	134	273	0.25125
15	59	16.1156	55	131	2.84421	95	203	0.73119	135	275	0.24512
16	61	15.3418	56	133	2.73823	96	205	0.70944	136	277	0.23916
17	63	14.6181	57	135	2.63682	97	207	0.68844	137	279	0.23338
18	64	13.918	58	136	2.53973	98	208	0.66818	138	280	0.22776
19	66	13.2631	59	138	2.44677	99	210	0.64862	139	282	0.22231

## ii) Temperature Sensor Resistance Value Table for TP (°C – K)

°C	°F	K Ohm	°C	°F	K Ohm	°C	°F	K Ohm	°C	°F	K Ohm
-20	-4	542.7	20	68	68.66	60	140	13.59	100	212	3.702
-19	-2	511.9	21	70	65.62	61	142	13.11	101	214	3.595
-18	0	483	22	72	62.73	62	144	12.65	102	216	3.492
-17	1	455.9	23	73	59.98	63	145	12.21	103	217	3.392
-16	3	430.5	24	75	57.37	64	147	11.79	104	219	3.296
-15	5	406.7	25	77	54.89	65	149	11.38	105	221	3.203
-14	7	384.3	26	79	52.53	66	151	10.99	106	223	3.113
-13	9	363.3	27	81	50.28	67	153	10.61	107	225	3.025
-12	10	343.6	28	82	48.14	68	154	10.25	108	226	2.941
-11	12	325.1	29	84	46.11	69	156	9.902	109	228	2.86
-10	14	307.7	30	86	44.17	70	158	9.569	110	230	2.781
-9	16	291.3	31	88	42.33	71	160	9.248	111	232	2.704
-8	18	275.9	32	90	40.57	72	162	8.94	112	234	2.63
-7	19	261.4	33	91	38.89	73	163	8.643	113	235	2.559
-6	21	247.8	34	93	37.3	74	165	8.358	114	237	2.489
-5	23	234.9	35	95	35.78	75	167	8.084	115	239	2.422
-4	25	222.8	36	97	34.32	76	169	7.82	116	241	2.357
-3	27	211.4	37	99	32.94	77	171	7.566	117	243	2.294
-2	28	200.7	38	100	31.62	78	172	7.321	118	244	2.233
-1	30	190.5	39	102	30.36	79	174	7.086	119	246	2.174
0	32	180.9	40	104	29.15	80	176	6.859	120	248	2.117
1	34	171.9	41	106	28	81	178	6.641	121	250	2.061
2	36	163.3	42	108	26.9	82	180	6.43	122	252	2.007
3	37	155.2	43	109	25.86	83	181	6.228	123	253	1.955
4	39	147.6	44	111	24.85	84	183	6.033	124	255	1.905
5	41	140.4	45	113	23.89	85	185	5.844	125	257	1.856
6	43	133.5	46	115	22.89	86	187	5.663	126	259	1.808
7	45	127.1	47	117	22.1	87	189	5.488	127	261	1.762
8	46	121	48	118	21.26	88	190	5.32	128	262	1.717
9	48	115.2	49	120	20.46	89	192	5.157	129	264	1.674
10	50	109.8	50	122	19.69	90	194	5	130	266	1.632
11	52	104.6	51	124	18.96	91	196	4.849			
12	54	99.69	52	126	18.26	92	198	4.703			
13	55	95.05	53	127	17.58	93	199	4.562			
14	57	90.66	54	129	16.94	94	201	4.426			
15	59	86.49	55	131	16.32	95	203	4.294			
16	61	82.54	56	133	15.73	96	205	4.167			
17	63	78.79	57	135	15.16	97	207	4.045			
18	64	75.24	58	136	14.62	98	208	3.927			
19	66	71.86	59	138	14.09	99	210	3.812			

### iii) Pressure On Service Port(R410A)

Cooling chart:

°F(°C)	ODU(DB)		0(-17)	5(-15)	15 (-9.44)	45 (7.22)	75 (23.89)	85 (29.44)	95 (35)	105 (40.56)	115 (46.11)	120 (48.89)
	IDU(DB/WB)											
BAR	70/59 (21.11/15)		6.4	6.5	7.3	8.0	8.2	7.8	8.1	8.6	10.1	10.6
	75/63 (23.89/17.22)		6.7	6.8	7.9	8.6	8.6	8.3	8.7	9.1	10.7	11.2
	80/67 (26.67/19.44)		7.1	7.2	8.5	9.5	9.3	8.9	9.1	9.6	11.2	11.9
	90/73 (32.22/22.78)		7.7	7.8	9.6	10.5	10.3	9.5	10.0	10.6	12.4	13.0
PSI	70/59 (21.11/15)		93	94	106	116	119	113	117	125	147	154
	75/63 (23.89/17.22)		97	99	115	125	124	120	126	132	155	162
	80/67 (26.67/19.44)		103	104	123	138	135	129	132	140	162	173
	90/73 (32.22/22.78)		112	113	139	152	149	138	145	154	180	189
MPa	70/59 (21.11/15)		0.64	0.65	0.73	0.8	0.82	0.78	0.81	0.86	1.01	1.06
	75/63 (23.89/17.22)		0.67	0.68	0.79	0.86	0.86	0.83	0.87	0.91	1.07	1.12
	80/67 (26.67/19.44)		0.71	0.72	0.85	0.95	0.93	0.89	0.91	0.96	1.12	1.19
	90/73 (32.22/22.78)		0.77	0.78	0.96	1.05	1.03	0.95	1	1.06	1.24	1.3

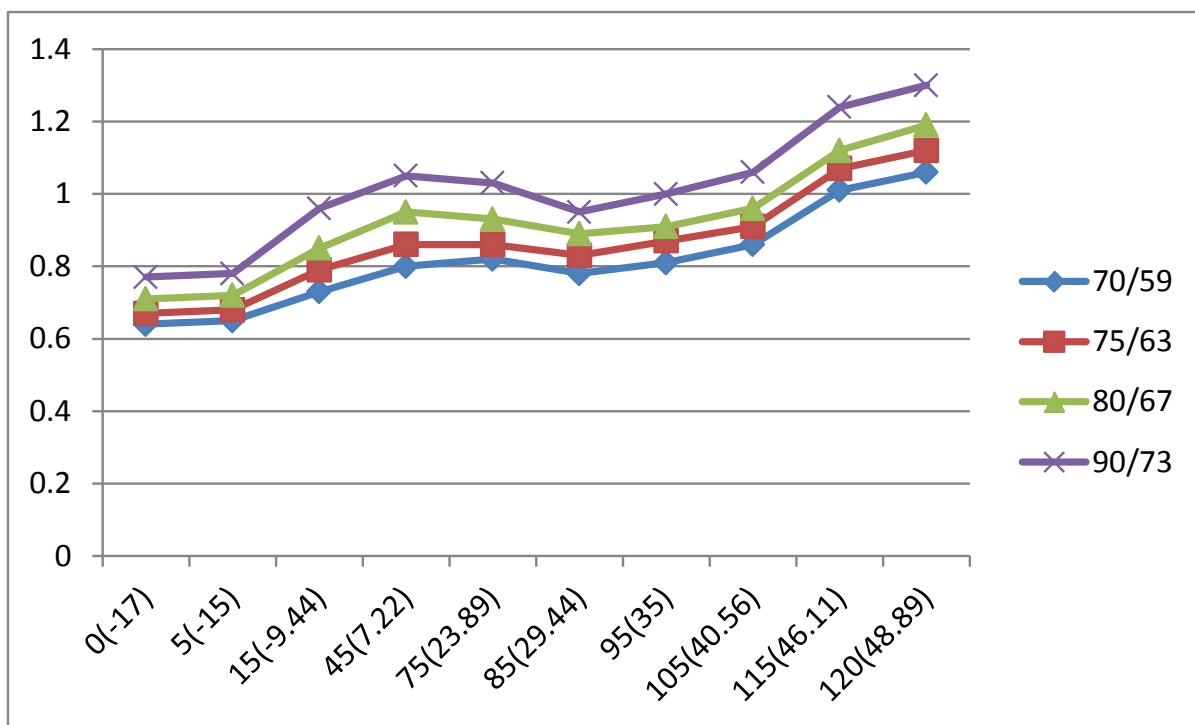

## Heating chart:

°F(°C)	ODU(DB/WB)	57/53 (13.89/11.67)	47/43 (8.33/6.11)	37/33 (2.78/0.56)	27/23 (-2.78/-5)	17/13 (-8.33/- 10.56)	0/-2 (-17/-19)	-17/-18 (-27/-28)
	IDU(DB)							
BAR	55(12.78)	30.3	28.5	25.3	22.8	20.8	18.5	16.5
	65(18.33)	32.5	30.0	26.6	25.4	23.3	20.5	19.0
	75(23.89)	33.8	31.5	27.8	26.3	24.9	21.5	20.0
PSI	55(12.78)	439	413	367	330	302	268	239
	65(18.33)	471	435	386	368	339	297	276
	75(23.89)	489	457	403	381	362	312	290
MPa	55(12.78)	3.03	2.85	2.53	2.28	2.08	1.85	1.65
	65(18.33)	3.25	3.00	2.66	2.54	2.33	2.05	1.90
	75(23.89)	3.38	3.15	2.78	2.63	2.49	2.15	2.00

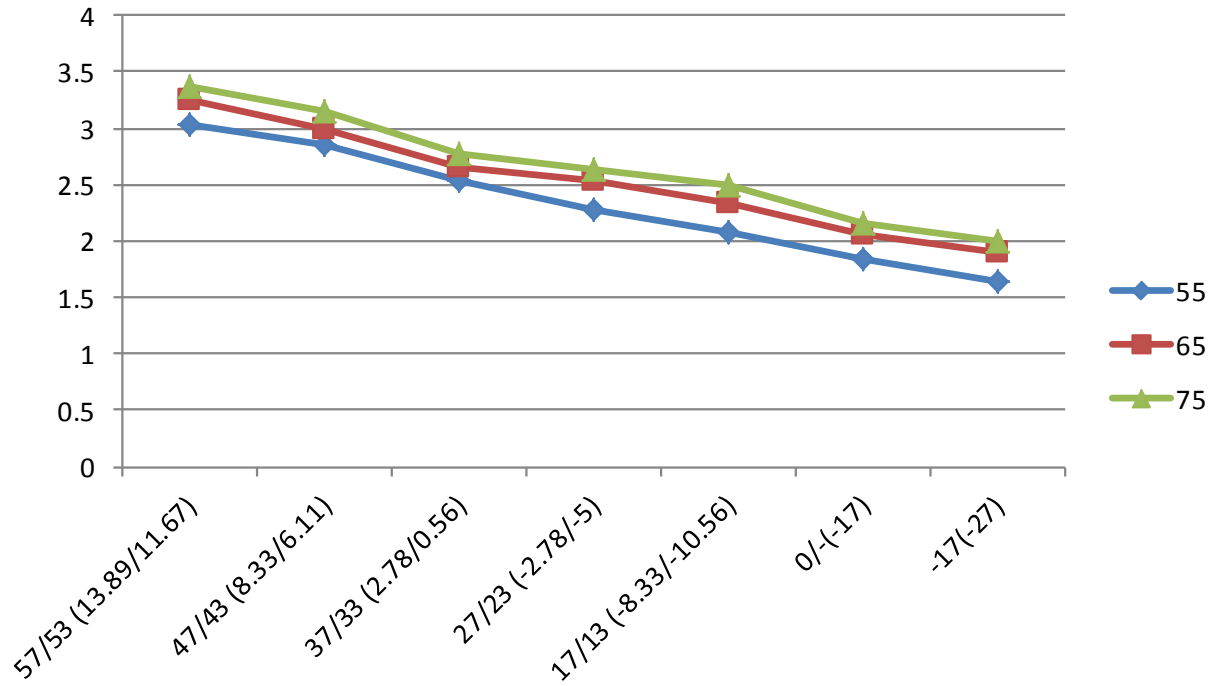



## System Pressure Table-R410A

Pressure			Temperature		Pressure			Temperature	
Kpa	bar	PSI	°C	°F	Kpa	bar	PSI	°C	°F
100	1	14.5	-51.623	-60.921	2350	23.5	340.75	38.817	101.871
150	1.5	21.75	-43.327	-45.989	2400	24	348	39.68	103.424
200	2	29	-36.992	-34.586	2450	24.5	355.25	40.531	104.956
250	2.5	36.25	-31.795	-25.231	2500	25	362.5	41.368	106.462
300	3	43.5	-27.351	-17.232	2550	25.5	369.75	42.192	107.946
350	3.5	50.75	-23.448	-10.206	2600	26	377	43.004	109.407
400	4	58	-19.953	-3.915	2650	26.5	384.25	43.804	110.847
450	4.5	65.25	-16.779	1.798	2700	27	391.5	44.592	112.266
500	5	72.5	-13.863	7.047	2750	27.5	398.75	45.37	113.666
550	5.5	79.75	-11.162	11.908	2800	28	406	46.136	115.045
600	6	87	-8.643	16.444	2850	28.5	413.25	46.892	116.406
650	6.5	94.25	-6.277	20.701	2900	29	420.5	47.638	117.748
700	7	101.5	-4.046	24.716	2950	29.5	427.75	48.374	119.073
750	7.5	108.75	-1.933	28.521	3000	30	435	49.101	120.382
800	8	116	0.076	32.137	3050	30.5	442.25	49.818	121.672
850	8.5	123.25	1.993	35.587	3100	31	449.5	50.525	122.945
900	9	130.5	3.826	38.888	3150	31.5	456.75	51.224	124.203
950	9.5	137.75	5.584	42.052	3200	32	464	51.914	125.445
1000	10	145	7.274	45.093	3250	32.5	471.25	52.596	126.673
1050	10.5	152.25	8.901	48.022	3300	33	478.5	53.27	127.886
1100	11	159.5	10.471	50.848	3350	33.5	485.75	53.935	129.083
1150	11.5	166.75	11.988	53.578	3400	34	493	54.593	130.267
1200	12	174	13.457	56.223	3450	34.5	500.25	55.243	131.437
1250	12.5	181.25	14.879	58.782	3500	35	507.5	55.885	132.593
1300	13	188.5	16.26	61.268	3550	35.5	514.75	56.52	133.736
1350	13.5	195.75	17.602	63.684	3600	36	522	57.148	134.866
1400	14	203	18.906	66.031	3650	36.5	529.25	57.769	135.984
1450	14.5	210.25	20.176	68.317	3700	37	536.5	58.383	137.089
1500	15	217.5	21.414	70.545	3750	37.5	543.75	58.99	138.182
1550	15.5	224.75	22.621	72.718	3800	38	551	59.591	139.264
1600	16	232	23.799	74.838	3850	38.5	558.25	60.185	140.333
1650	16.5	239.25	24.949	76.908	3900	39	565.5	60.773	141.391
1700	17	246.5	26.074	78.933	3950	39.5	572.75	61.355	142.439
1750	17.5	253.75	27.174	80.913	4000	40	580	61.93	143.474
1800	18	261	28.251	82.852	4050	40.5	587.25	62.499	144.498
1850	18.5	268.25	29.305	84.749	4100	41	594.5	63.063	145.513
1900	19	275.5	30.338	86.608	4150	41.5	601.75	63.62	146.516
1950	19.5	282.75	31.351	88.432	4200	42	609	64.172	147.510
2000	20	290	32.344	90.219	4250	42.5	616.25	64.719	148.494
2050	20.5	297.25	33.319	91.974	4300	43	623.5	65.259	149.466
2100	21	304.5	34.276	93.697	4350	43.5	630.75	65.795	150.431
2150	21.5	311.75	35.215	95.387	4400	44	638	66.324	151.383
2200	22	319	36.139	97.050	4450	44.5	645.25	66.849	152.328
2250	22.5	326.25	37.047	98.685	4500	45	652.5	67.368	153.262
2300	23	333.5	37.939	100.290					