



---

## SERVICE MANUAL

**MOOVAIR MODEL**

DUB12HIFU230X5A  
DMA12HOS25230E8  
DMA12HOS28230E8

**FACTORY CODE**

MFA2U-12HRFN1-MW5W  
MOX230-12HFN1-MV5W  
MOX330-12HFN1-MW5W

**PRODUCT CODE**

22022611000207  
22022016016322  
22022016016220



SM\_NEW CONSOLE(GA)\_R410A\_3D INV\_US1\_NA\_2207

# CONSOLE INVERTER SERIES

---

SERVICE MANUAL

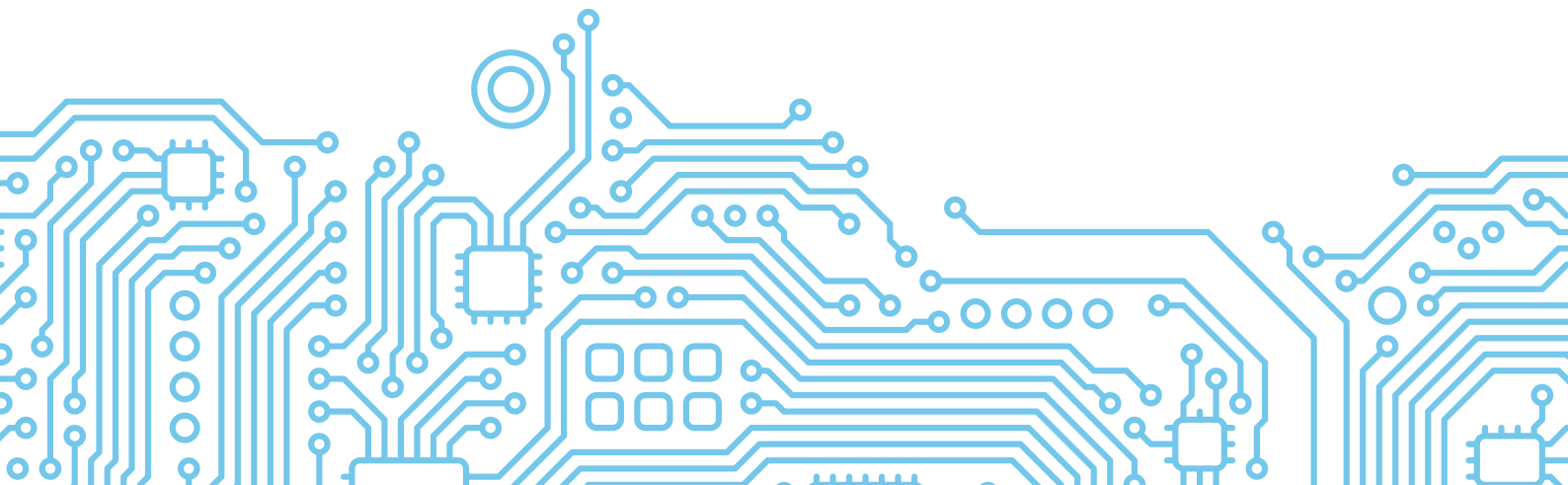
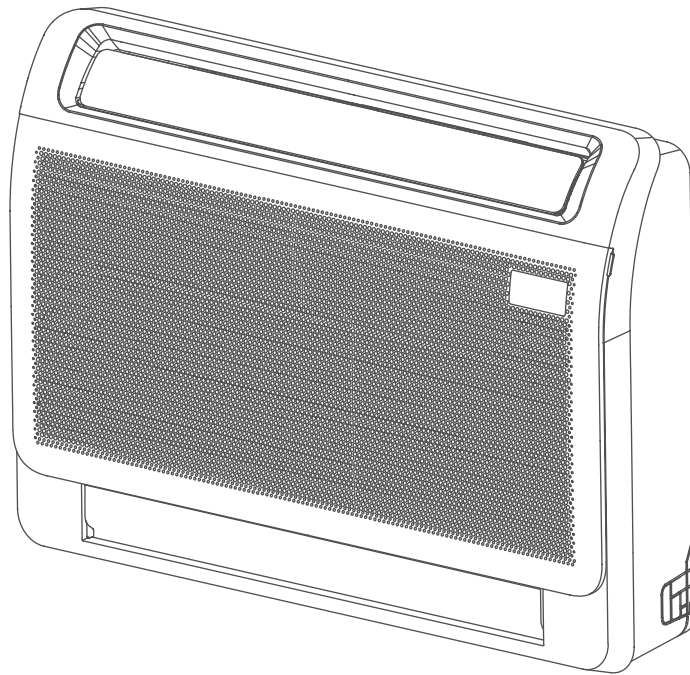



---

## Table of Contents

---

### §. Safety Precautions

1. Precautions
2. Information servicing

### §. Model Reference & External Appearance

1. Model Reference
2. External Appearance

### §. Indoor Unit

1. Indoor Unit - New Console Type

### §. Outdoor Unit

1. Dimensional Drawings
2. Service Space
3. Capacity Correction Factor for Height Difference
4. Noise Criterion Curves
5. Refrigerant Cycle Diagrams
6. Electrical Wiring Diagrams

### §. Installation

### §. Maintenance

### §. Product Features

---

---

## Table of Contents

---

### §. Troubleshooting

1. Safety Caution
2. General Troubleshooting
3. Information Inquiry
4. Error Diagnosis and Troubleshooting Without Error Code
5. Quick Maintenance by Error Code
6. Troubleshooting by Error Code
7. Check Procedures

### §. Indoor Unit Disassembly

1. Indoor Unit - New Console Type

### §. Outdoor Unit Disassembly

### Appendix

- i) Temperature Sensor Resistance Value Table for T1,T2,T3 and T4 (°C – K)
- ii) Temperature Sensor Resistance Value Table for TP(for some units) (°C – K)
- iii) Pressure On Service Port



---

# Safety Precautions

## Contents

1.	Precautions.....	2
2.	Information servicing(For flammable materials).....	3

## 1. Precautions

To prevent personal injury, or property or unit damage, adhere to all precautionary measures and instructions outlined in this manual. Before servicing a unit, refer to this service manual and its relevant sections.

Failure to adhere to all precautionary measures listed in this section may result in personal injury, damage to the unit or to property, or in extreme cases, death.

 **WARNING** indicates a potentially hazardous situation which if not avoided could result in serious personal injury, or death.

 **CAUTION** indicates a potentially hazardous situation which if not avoided could result in minor or moderate personal injury, or unit damage.

### 1.1 In case of Accidents or Emergency

 **WARNING**

- If a gas leak is suspected, immediately turn off the gas and ventilate the area if a gas leak is suspected before turning the unit on.
- If strange sounds or smoke is detected from the unit, turn the breaker off and disconnect the power supply cable.
- If the unit comes into contact with liquid, contact an authorized service center.
- If liquid from the batteries makes contact with skin or clothing, immediately rinse or wash the area well with clean water.
- Do not insert hands or other objects into the air inlet or outlet while the unit is plugged in.
- Do not operate the unit with wet hands.
- Do not use a remote controller that has previously been exposed to battery damage or battery leakage.

 **CAUTION**

- Clean and ventilate the unit at regular intervals when operating it near a stove or near similar devices.
- Do not use the unit during severe weather conditions. If possible, remove the product from the window before such occurrences.

### 1.2 Pre-Installation and Installation

 **WARNING**

- Use this unit only on a dedicated circuit.
- Damage to the installation area could cause the unit to fall, potentially resulting in personal injury, property damage, or product failure.
- Only qualified personnel should disassemble, install, remove, or repair the unit.
- Only a qualified electrician should perform electrical work. For more information, contact your dealer, seller, or an authorized service center.

 **CAUTION**

- While unpacking be careful of sharp edges around the unit as well as the edges of the fins on the condenser and evaporator.

### 1.3 Operation and Maintenance

 **WARNING**

- Do not use defective or under-rated circuit breakers.
- Ensure the unit is properly grounded and that a dedicated circuit and breaker are installed.
- Do not modify or extend the power cable. Ensure the power cable is secure and not damaged during operation.
- Do not unplug the power supply plug during operation.
- Do not store or use flammable materials near the unit.
- Do not open the inlet grill of the unit during operation.
- Do not touch the electrostatic filter if the unit is equipped with one.
- Do not block the inlet or outlet of air flow to the unit.
- Do not use harsh detergents, solvents, or similar items to clean the unit. Use a soft cloth for cleaning.
- Do not touch the metal parts of the unit when removing the air filter as they are very sharp.
- Do not step on or place anything on the unit or outdoor units.
- Do not drink water drained from the unit
- Avoid direct skin contact with water drained from the unit.
- Use a firm stool or step ladder according to manufacturer procedures when cleaning or maintaining the unit.

 **CAUTION**

- Do not install or operate the unit for an extended period of time in areas of high humidity or in an environment directly exposing it to sea wind or salt spray.
- Do not install the unit on a defective or damaged installation stand, or in an unsecure location.
- Ensure the unit is installed at a level position
- Do not install the unit where noise or air discharge created by the outdoor unit will negatively impact the environment or nearby residences.
- Do not expose skin directly to the air discharged by the unit for prolonged periods of time.
- Ensure the unit do not operate in areas water or other liquids.
- Ensure the drain hose is installed correctly to ensure proper water drainage.
- When lifting or transporting the unit, it is recommended that two or more people are used for this task.
- When the unit is not to be used for an extended time, disconnect the power supply or turn off the breaker.



---

## 2. Information servicing(For flammable materials)

### 2.1 Checks to the area

- Prior to beginning work on systems containing flammable refrigerants, safety checks are necessary to ensure that the risk of ignition is minimized. For repair to the refrigerating system, the following precautions shall be complied with prior to conducting work on the system.

### 2.2 Work procedure

- Works shall be undertaken under a controlled procedure so as to minimise the risk of a flammable gas or vapour being present while the work is being performed. Technical personnel in charge of operation, supervision, maintenance of air-conditioning systems shall be adequately instructed and competent with respect to their tasks. Works shall be undertaken with appropriate tools only (In case of uncertainty, please consult the manufacturer of the tools for use with flammable refrigerants)

### 2.3 General work area

- All maintenance staff and others working in the local area shall be instructed on the nature of work being carried out. work in confined spaces shall be avoided. The area around the work space shall be sectioned off. Ensure that the conditions within the area have been made safe by control of flammable material.

### 2.4 Checking for presence of refrigerant

- The area shall be checked with an appropriate refrigerant detector prior to and during work, to ensure the technician is aware of potentially flammable atmospheres. Ensure that the leak detection equipment being used is suitable for use with flammable refrigerants, i.e. no sparking, adequately sealed or intrinsically safe.

### 2.5 Presence of fire extinguisher

- If any hot work is to be conducted on the refrigeration equipment or any associated parts, appropriate fire extinguishing equipment shall be available to hand. Have a dry powder or CO2 fire extinguisher adjacent to the charging area.

### 2.6 No ignition sources

- No person carrying out work in relation to a refrigeration system which involves exposing any pipe work that contains or has contained flammable refrigerant shall use any sources of ignition in such a manner that it may lead to the risk of fire or explosion. All possible ignition sources, including cigarette smoking, should be kept sufficiently far away from the site of installation, repairing, removing and disposal, during which flammable refrigerant can possibly be released

to the surrounding space. Prior to work taking place, the area around the equipment is to be surveyed to make sure that there are no flammable hazards or ignition risks. NO SMOKING signs shall be displayed.

### 2.7 Ventilated area

- Ensure that the area is in the open or that it is adequately ventilated before breaking into the system or conducting any hot work. A degree of ventilation shall continue during the period that the work is carried out. The ventilation should safely disperse any released refrigerant and preferably expel it externally into the atmosphere.

### 2.8 Checks to the refrigeration equipment

- Where electrical components are being changed, they shall be fit for the purpose and to the correct specification. At all times the manufacturer's maintenance and service guidelines shall be followed. If in doubt consult the manufacturer's technical department for assistance. The following checks shall be applied to installations using flammable refrigerants:
  - the charge size is in accordance with the room size within which the refrigerant containing parts are installed;
  - the ventilation machinery and outlets are operating adequately and are not obstructed;
  - if an indirect refrigerating circuit is being used, the secondary circuit shall be checked for the presence of refrigerant; marking to the equipment continues to be visible and legible.
  - markings and signs that are illegible shall be corrected;
  - refrigeration pipe or components are installed in a position where they are unlikely to be exposed to any substance which may corrode refrigerant containing components, unless the components are constructed of materials which are inherently resistant to being corroded or are suitably protected against being so corroded.

### 2.9 Checks to electrical devices

- Repair and maintenance to electrical components shall include initial safety checks and component inspection procedures. If a fault exists that could compromise safety, then no electrical supply shall be connected to the circuit until it is satisfactorily dealt with. If the fault cannot be corrected immediately but it is necessary to continue operation, and adequate temporary solution shall be used. This shall be reported to the owner of the equipment so all parties are advised.

**Initial safety checks shall include:**

- that capacitors are discharged: this shall be done in a safe manner to avoid possibility of sparking
- that there no live electrical components and wiring are exposed while charging, recovering or purging the system;
- that there is continuity of earth bonding.

## 2.10 Repairs to sealed components

- During repairs to sealed components, all electrical supplies shall be disconnected from the equipment being worked upon prior to any removal of sealed covers, etc. If it is absolutely necessary to have an electrical supply to equipment during servicing, then a permanently operating form of leak detection shall be located at the most critical point to warn of a potentially hazardous situation.
- Particular attention shall be paid to the following to ensure that by working on electrical components, the casing is not altered in such a way that the level of protection is affected. This shall include damage to cables, excessive number of connections, terminals not made to original specification, damage to seals, incorrect fitting of glands, etc.
  - Ensure that apparatus is mounted securely.
  - Ensure that seals or sealing materials have not degraded such that they no longer serve the purpose of preventing the ingress of flammable atmospheres. Replacement parts shall be in accordance with the manufacturer's specifications.

NOTE: The use of silicon sealant may inhibit the effectiveness of some types of leak detection equipment. Intrinsically safe components do not have to be isolated prior to working on them.

## 2.11 Repair to intrinsically safe components

- Do not apply any permanent inductive or capacitance loads to the circuit without ensuring that this will not exceed the permissible voltage and current permitted for the equipment in use. Intrinsically safe components are the only types that can be worked on while live in the presence of a flammable atmosphere. The test apparatus shall be at the correct rating.
- Replace components only with parts specified by the manufacturer. Other parts may result in the ignition of refrigerant in the atmosphere from a leak.

## 2.12 Cabling

- Check that cabling will not be subject to wear, corrosion, excessive pressure, vibration, sharp edges or any other adverse environmental effects. The check

shall also take into account the effects of aging or continual vibration from sources such as compressors or fans.

## 2.13 Detection of flammable refrigerants

- Under no circumstances shall potential sources of ignition be used in the searching for or detection of refrigerant leaks. A halide torch (or any other detector using a naked flame) shall not be used.

## 2.14 Leak detection methods

- The following leak detection methods are deemed acceptable for systems containing flammable refrigerants. Electronic leak detectors shall be used to detect flammable refrigerants, but the sensitivity may not be adequate, or may need re-calibration. (Detection equipment shall be calibrated in a refrigerant-free area.) Ensure that the detector is not a potential source of ignition and is suitable for the refrigerant used. Leak detection equipment shall be set at a percentage of the LFL of the refrigerant and shall be calibrated to the refrigerant employed and the appropriate percentage of gas (25 % maximum) is confirmed. Leak detection fluids are suitable for use with most refrigerants but the use of detergents containing chlorine shall be avoided as the chlorine may react with the refrigerant and corrode the copper pipe-work.
  - If a leak is suspected, all naked flames shall be removed or extinguished.
  - If a leakage of refrigerant is found which requires brazing, all of the refrigerant shall be recovered from the system, or isolated (by means of shut off valves) in a part of the system remote from the leak. Oxygen free nitrogen (OFN) shall then be purged through the system both before and during the brazing process.

## 2.15 Removal and evacuation

- When breaking into the refrigerant circuit to make repairs or for any other purpose, conventional procedures shall be used. However, it is important that best practice is followed since flammability is a consideration.
- The following procedure shall be adhered to:
  - remove refrigerant;
  - purge the circuit with inert gas;
  - evacuate;
  - purge again with inert gas;
  - open the circuit by cutting or brazing.

- The refrigerant charge shall be recovered into the correct recovery cylinders. The system shall be flushed with OFN to render the unit safe. This process may need to be repeated several times. Compressed air or oxygen shall not be used for this task. Flushing shall be achieved by breaking the vacuum in the system with OFN and continuing to fill until the working pressure is achieved, then venting to atmosphere, and finally pulling down to a vacuum. This process shall be repeated until no refrigerant is within the system. When the final OFN charge is used, the system shall be vented down to atmospheric pressure to enable work to take place. This operation is absolutely vital if brazing operations on the pipe-work are to take place.
- Ensure that the outlet for the vacuum pump is not close to any ignition sources and there is ventilation available.

## 2.16 Charging procedures

- In addition to conventional charging procedures, the following requirements shall be followed:
  - Ensure that contamination of different refrigerants does not occur when using charging equipment. Hoses or lines shall be as short as possible to minimize the amount of refrigerant contained in them.
  - Cylinders shall be kept upright.
  - Ensure that the refrigeration system is earthed prior to charging the system with refrigerant.
  - Label the system when charging is complete (if not already).
  - Extreme care shall be taken not to overfill the refrigeration system.
  - Prior to recharging the system it shall be pressure tested with OFN. The system shall be leak tested on completion of charging but prior to commissioning. A follow up leak test shall be carried out prior to leaving the site.

## 2.17 Decommissioning

Before carrying out this procedure, it is essential that the technician is completely familiar with the equipment and all its detail. It is recommended good practice that all refrigerants are recovered safely. Prior to the task being carried out, an oil and refrigerant sample shall be taken.

In case analysis is required prior to re-use of reclaimed refrigerant. It is essential that electrical power is available before the task is commenced.

- Become familiar with the equipment and its operation.
- Isolate system electrically.

- Before attempting the procedure ensure that:
  - mechanical handling equipment is available, if required, for handling refrigerant cylinders;
  - all personal protective equipment is available and being used correctly;
  - the recovery process is supervised at all times by a competent person;
  - recovery equipment and cylinders conform to the appropriate standards.
- Pump down refrigerant system, if possible.
- If a vacuum is not possible, make a manifold so that refrigerant can be removed from various parts of the system.
- Make sure that cylinder is situated on the scales before recovery takes place.
- Start the recovery machine and operate in accordance with manufacturer's instructions.
- Do not overfill cylinders. (No more than 80 % volume liquid charge).
- Do not exceed the maximum working pressure of the cylinder, even temporarily.
- When the cylinders have been filled correctly and the process completed, make sure that the cylinders and the equipment are removed from site promptly and all isolation valves on the equipment are closed off.
- Recovered refrigerant shall not be charged into another refrigeration system unless it has been cleaned and checked.

## 2.18 Labelling

- Equipment shall be labelled stating that it has been de-commissioned and emptied of refrigerant. The label shall be dated and signed. Ensure that there are labels on the equipment stating the equipment contains flammable refrigerant.

## 2.19 Recovery

- When removing refrigerant from a system, either for servicing or decommissioning, it is recommended good practice that all refrigerants are removed safely.
- When transferring refrigerant into cylinders, ensure that only appropriate refrigerant recovery cylinders are employed. Ensure that the correct numbers of cylinders for holding the total system charge are available. All cylinders to be used are designated for the recovered refrigerant and labelled for that refrigerant (i.e. special cylinders for the recovery of refrigerant). Cylinders shall be complete with pressure relief valve and associated shut-off valves in good working order.

- Empty recovery cylinders are evacuated and, if possible, cooled before recovery occurs.
- The recovery equipment shall be in good working order with a set of instructions concerning the equipment that is at hand and shall be suitable for the recovery of flammable refrigerants. In addition, a set of calibrated weighing scales shall be available and in good working order.
- Hoses shall be complete with leak-free disconnect couplings and in good condition. Before using the recovery machine, check that it is in satisfactory working order, has been properly maintained and that any associated electrical components are sealed to prevent ignition in the event of a refrigerant release. Consult manufacturer if in doubt.
- The recovered refrigerant shall be returned to the refrigerant supplier in the correct recovery cylinder, and the relevant Waste Transfer Note arranged. Do not mix refrigerants in recovery units and especially not in cylinders.
- If compressors or compressor oils are to be removed, ensure that they have been evacuated to an acceptable level to make certain that flammable refrigerant does not remain within the lubricant. The evacuation process shall be carried out prior to returning the compressor to the suppliers. Only electric heating to the compressor body shall be employed to accelerate this process. When oil is drained from a system, it shall be carried out safely.

## 2.20 Venting of HC Refrigerant (R290)

Venting may be carried out as an alternative to recovering the refrigerant. Because HC refrigerants have no ODP and negligible GWP, under certain circumstances it may be considered acceptable to vent the refrigerant. However, if this is to be considered, it should be done in accordance with the relevant national rules or regulations, if they permit.

In particular, before venting a system, it would be necessary to:

- Ensure that legislation relating to waste material has been considered
- Ensure that environmental legislation has been considered
- Ensure that legislation addressing safety of hazardous substances is satisfied
- Venting is only carried out with systems that contain a small quantity of refrigerant, typically less than 500 g.
- Venting to inside a building is not permissible under any circumstances
- Venting must not be to a public area, or where people

are unaware of the procedure taking place

- The hose must be of sufficient length and diameter such that it will extend to at least 3 m beyond the outside of the building
- The venting should only take place on the certainty that the refrigerant will not get blown back into any adjacent buildings, and that it will not migrate to a location below ground level
- The hose is made of material that is compatible for use with HC refrigerants and oil
- A device is used to raise the hose discharge at least 1 m above ground level and so that the discharge is pointed in an upwards direction (to assist with dilution)
- The end of the hose can now discharge and disperse the flammable fumes into the ambient air.
- There should not be any restriction or sharp bends within the vent-line which will hinder the ease of flow.
- There must be no sources of ignition near the hose discharge
- The hose should be regularly checked to ensure that there are no holes or kinks in it, that could lead to leakage or blocking of the passage of flow

When carrying out the venting, the flow of refrigerant should be metered using manifold gauges to a low flow rate, so as to ensure the refrigerant is well diluted. Once the refrigerant has ceased flowing, if possible, the system should be flushed out with OFN; if not, then the system should be pressurised with OFN and the venting procedure carried out two or more times, to ensure that there is minimal HC refrigerant remaining inside the system.

---

# Model Reference

## Contents

1.	Model Reference.....	2
2	External Appearance.....	3

---

## 1. Model Reference

Refer to the following table to determine the specific indoor and outdoor unit model number of your purchased equipment.

Indoor Unit Model		Universal Outdoor Unit Model	Capacity (Btu/h)	Power Supply
Console	MFA2U-12HRFN1-MW5W	MOX230-12HFN1-MV5W	9k	1Phase, 208/230V~, 60Hz
		MOX330-12HFN1-MW5W	9k Hyper Heat	
		MOX230-12HFN1-MV5W	12k	
		MOX330-12HFN1-MW5W	12k Hyper Heat	
	MFA2U-16HRFN1-MV0W	MOX430-18HFN1-MU0W	18k	
		MOX430-17HFN1-MT0W	18k Hyper Heat	

---

## 2. External Appearance

### 2.1 Indoor Unit

New Console



### 2.2 Outdoor Unit

Single Fan Outdoor Unit



---

# Indoor Unit-New Console

## Contents

1.	Feature.....	2
2.	Dimensional Drawings.....	4
3.	Part names .....	5
4.	Service Place.....	5
5.	Accessories .....	6
6	Air Velocity and Temperature Distributions .....	8
7.	Noise Criterion Curves.....	10
8.	Electrical Characteristics.....	11
9.	Electrical Wiring Diagrams.....	11



---

## 1. Feature

### 1.1 An Elegant And Compact Design

- The look of newly-upgraded console unit features flowing lines that is aesthetic enough.
- Its unobtrusive design can easily fit into most interiors with different decorating-schemes.
- The width of the machine has been reduced by 10mm, taking less space.

### 1.2 A Perfect Choice For New Buildings And Renovation Projects

- Console unit can be installed standing on the floor, or wall-mounted
- It is a great option for radiator replacement in order to save your space while provide more functions.

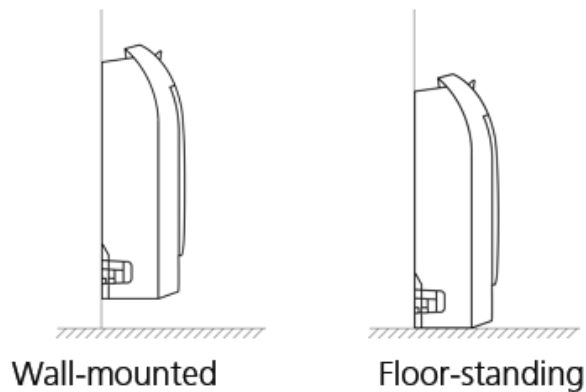

### 1.3 Dual Air Outlets With Larger Dimension

Efficiently improve air volume, providing constant, quick cooling and heating throughout whole year.

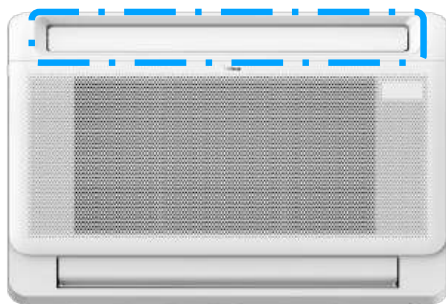

**65.3% LARGER upper air outlet\***

Dimension changes from  
516mm\*43mm to 655mm\*56mm

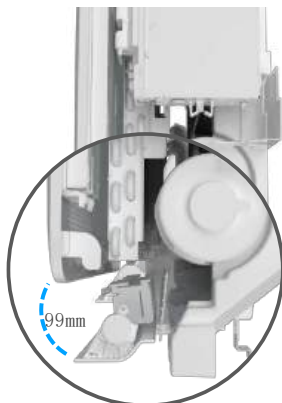

**94.1% WIDER lower air outlet\***

99mm large lower air out deliver  
even warm air distribution

- 
- Wide Airflow & Constant Comfort-Dual air outlets satisfy both cooling and heating needs in different seasons and allows a quick comfort of the room.

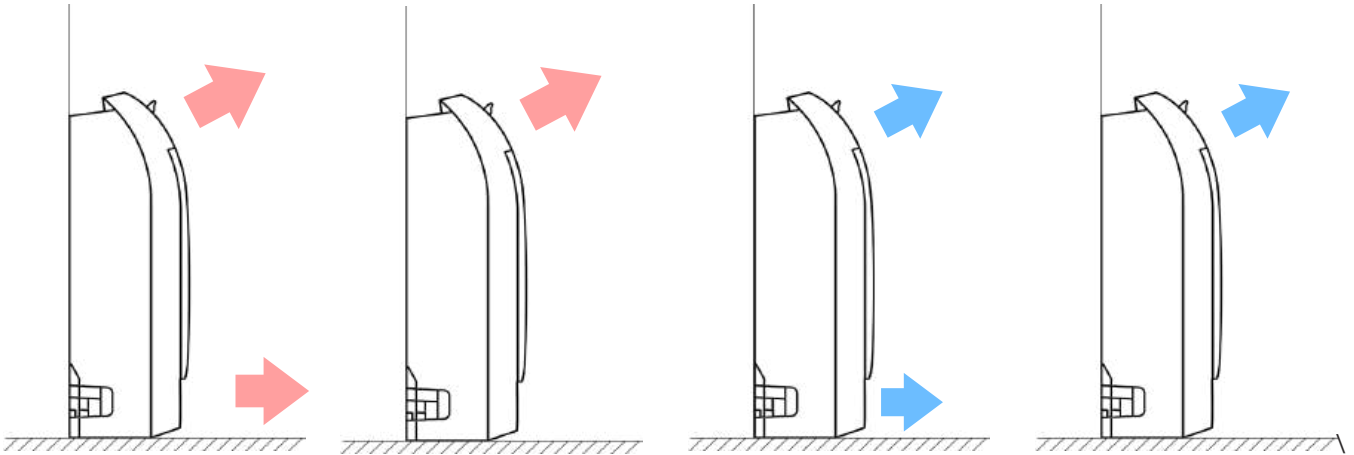

\*Compared to last generation console unit

## 1.4 Air Quality

We care your indoor air quality from many perspectives

- Get Ideal HUMIDITY for You
  - New console efficiently dehumidify the air to keep the ambient air dry and at comfort humidity level.
  - Display screen on front panel is reliable and user-friendly to operate to use.



- Ion-Generator for a Space with Better Air Quality
  - A built-in positive & negative ion generator in Midea console produces powerful ions that binds to and neutralises airborne pollutants for a cleaner environment.
  - Ions attach to airborne particles, which are then later collected onto an oppositely-charged flat plate.

## 2. Dimensional Drawings

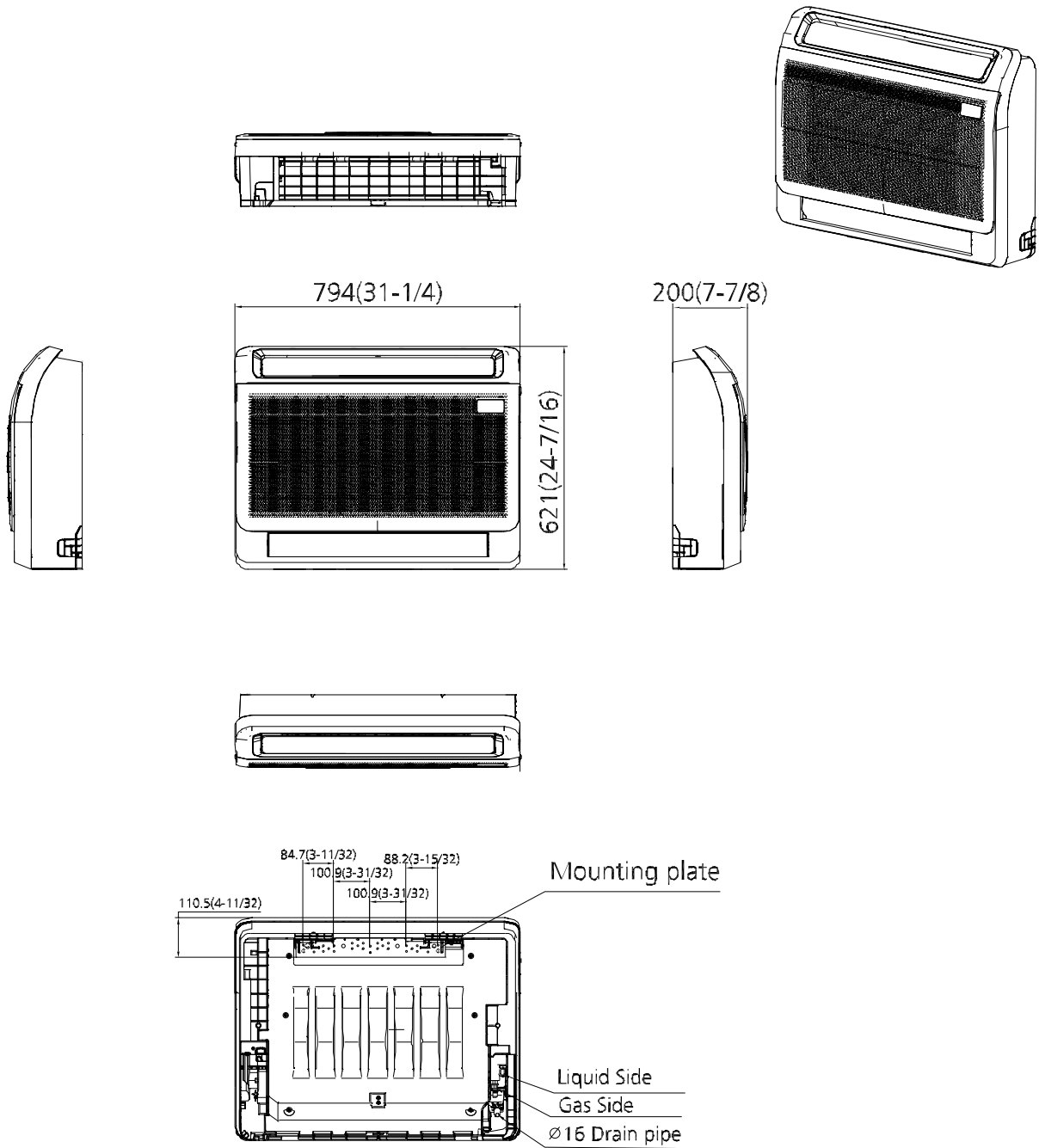

### 3. Part names

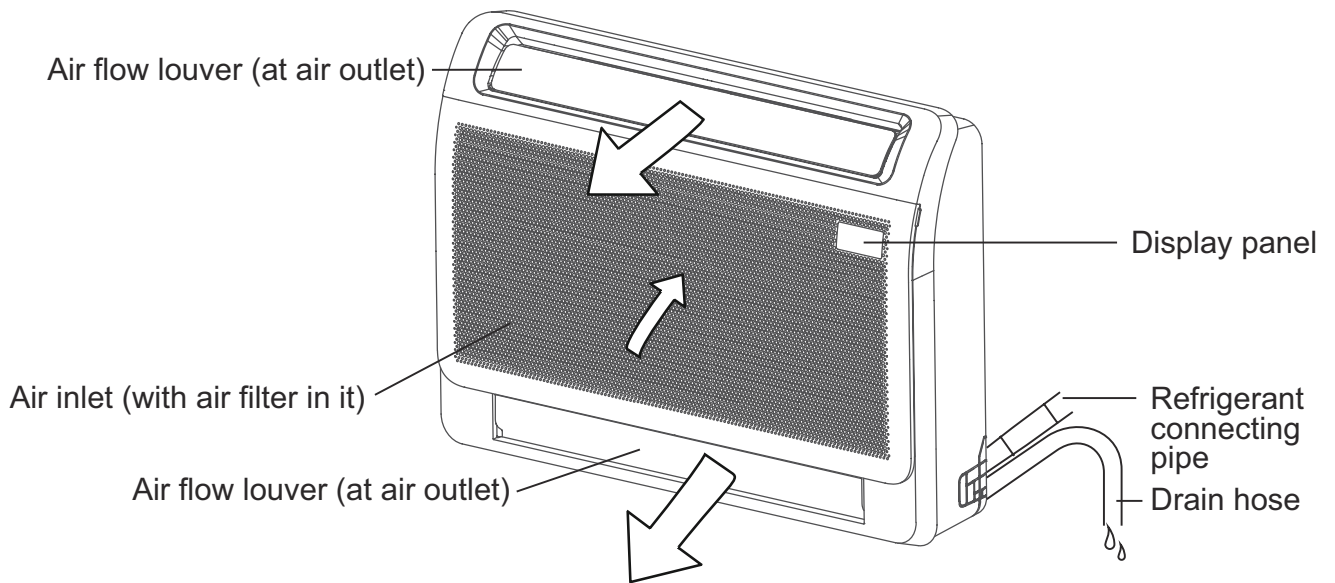



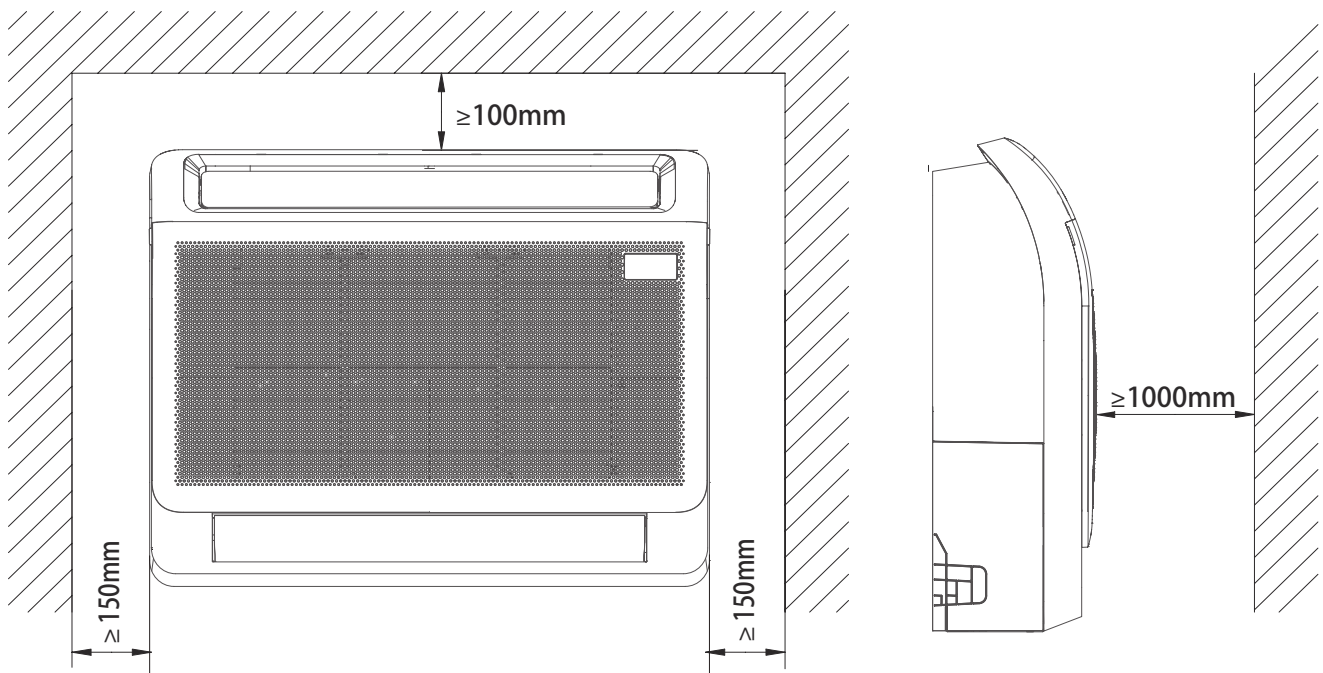





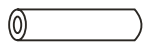
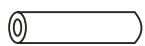

### 4. Service Place

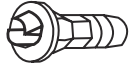

## 5. Accessories

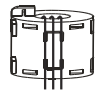
The air conditioning system comes with the following accessories. Use all of the installation parts and accessories to install the air conditioner. Improper installation may result in water leakage, electrical shock and fire, or equipment failure.

Name	Shape	Quantity
Remote controller		1
Battery (some models)		2
Wired remote controller(some models)		1
Manual	-	2-4
Air freshening filter (some models)		2
Soundproof/insulation sheath (some models)		2
Heat insulation pipe		1
Anchor		6(depending on models)
Mounting plate fixing screw		6(depending on models)
Copper nut		2
Hook		2
Drain joint (some models)		1
Seal ring (some models)		1
Magnetic ring (wrap the electric wires S1 & S2 ( P & Q & E ) around the magnetic ring twice)	 S1&S2(P&Q&E)	1
Magnetic ring (Hitch on the connective cable between the indoor unit and outdoor unit after installation.)(some models)		1

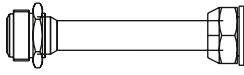
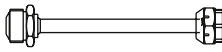
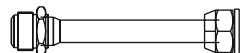
Transfer connector( $\Phi 12.7$ - $\Phi 15.9$ )/( $\Phi 0.5$ in- $\Phi 0.63$ in)(Packed with the indoor unit) NOTE: Pipe size may differ from appliance to appliance. To meet different pipe size requirements, sometimes the pipe connections need a transfer connector installed on the outdoor unit .		1 (on some models)
Transfer connector( $\Phi 6.35$ - $\Phi 9.52$ )/( $\Phi 0.25$ in- $\Phi 0.37$ in)(Packed with the indoor unit) NOTE: Pipe size may differ from appliance to appliance. To meet different pipe size requirements, sometimes the pipe connections need a transfer connector installed on the outdoor unit .		1 (on some models)
Transfer connector( $\Phi 9.52$ - $\Phi 12.7$ )/( $\Phi 0.375$ in- $\Phi 0.5$ in)(Packed with the indoor unit) NOTE: Pipe size may differ from appliance to appliance. To meet different pipe size requirements, sometimes the pipe connections need a transfer connector installed on the outdoor unit .		1 (on some models)
Red short connected wire (Applied to the W/L pin of outdoor unit terminal block be short-circuited.)	-	1 (on some models)

Optional accessories:

- There are two types of remote controls: wired and wireless.
- Select a remote controller based on customer preferences and requirements and install in an appropriate place.
- Refer to catalogues and technical literature for guidance on selecting a suitable remote controller.

## 6. Air Velocity and Temperature Distributions

Discharge Angle 70°(Upper)/ 0°(Lower)

Cooling airflow velocity distributions

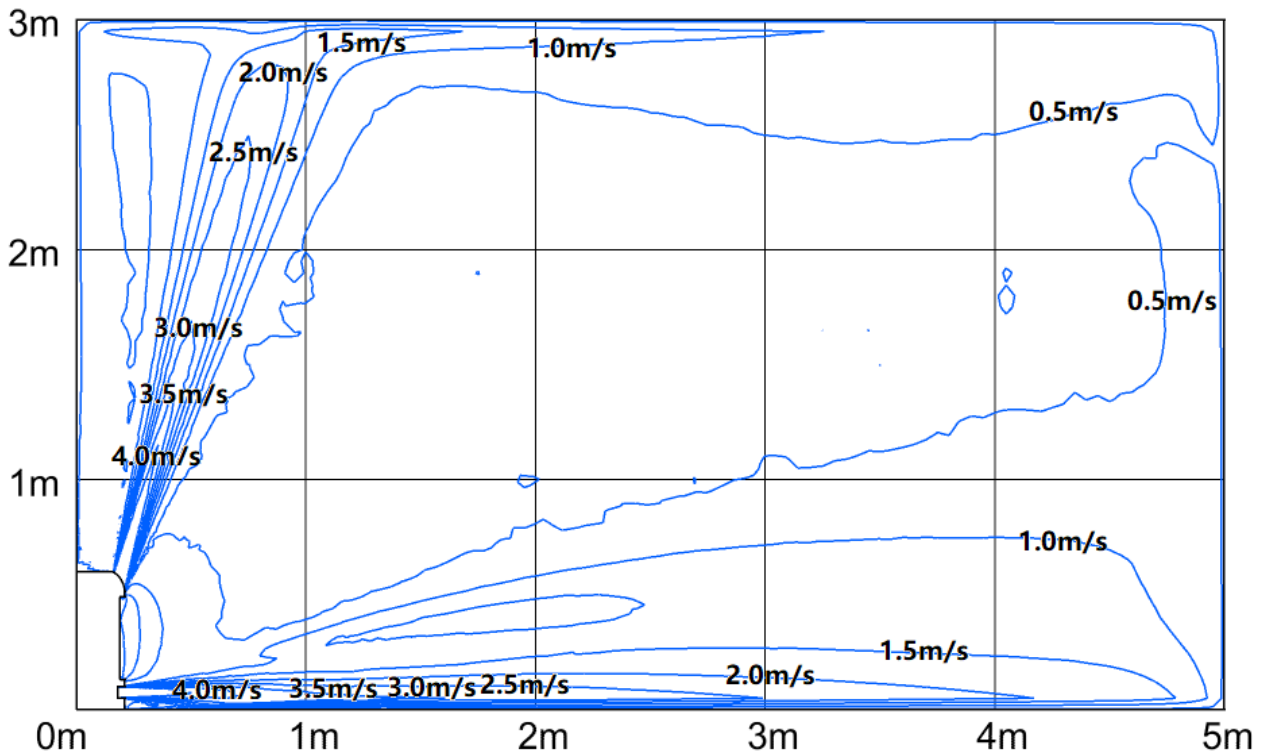

Cooling temperature distributions

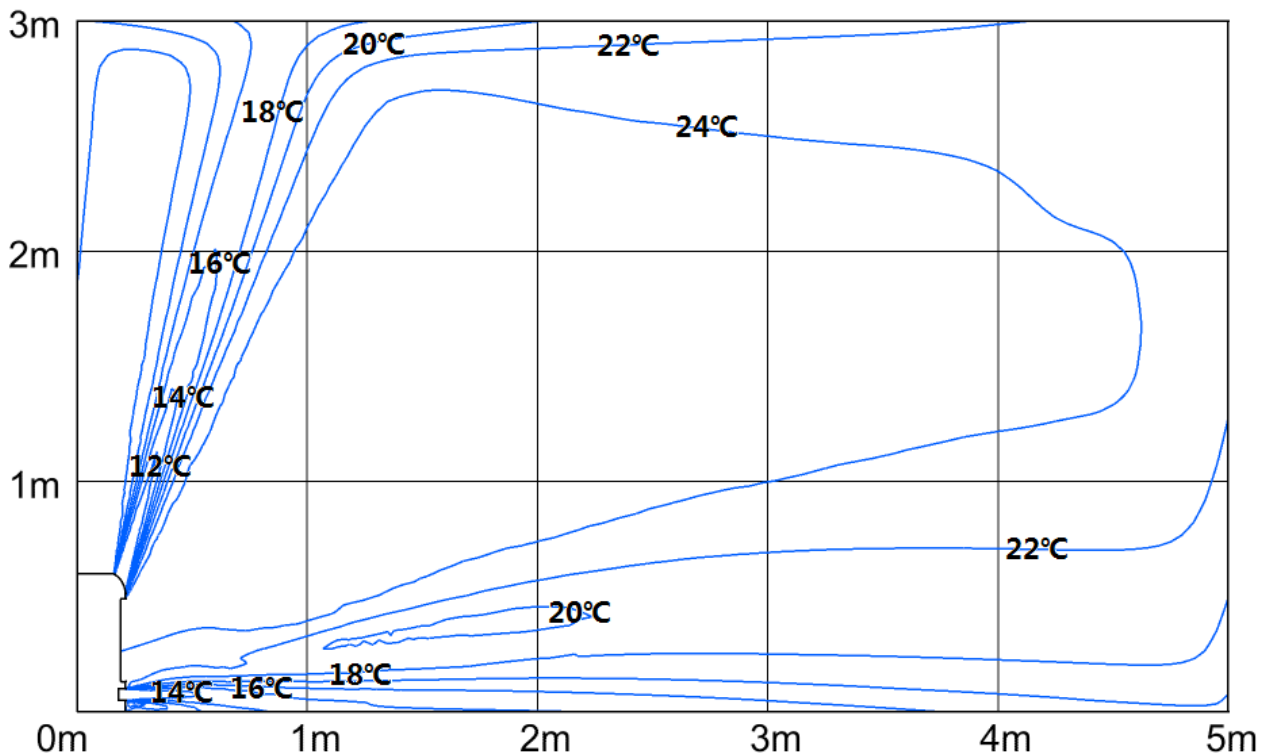

Discharge Angle 20°(Upper)/ 0°(Lower)

Heating airflow velocity distributions

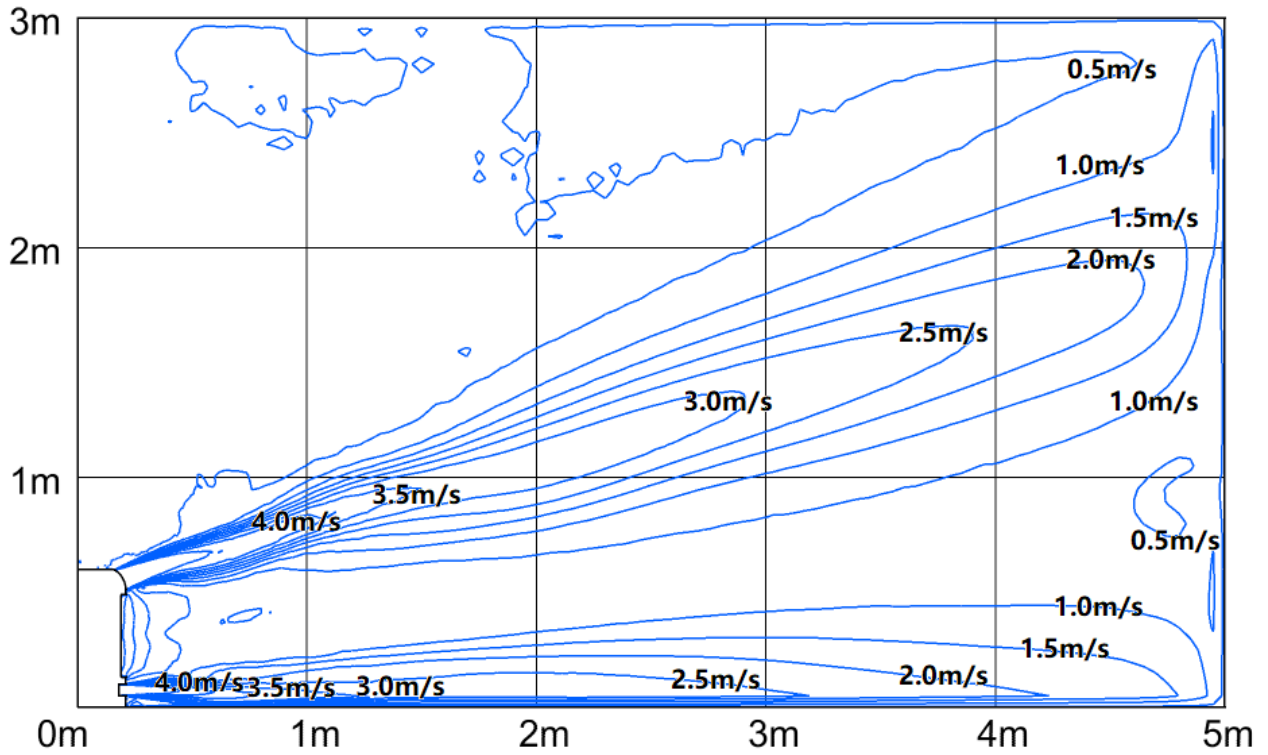

Heating temperature distributions

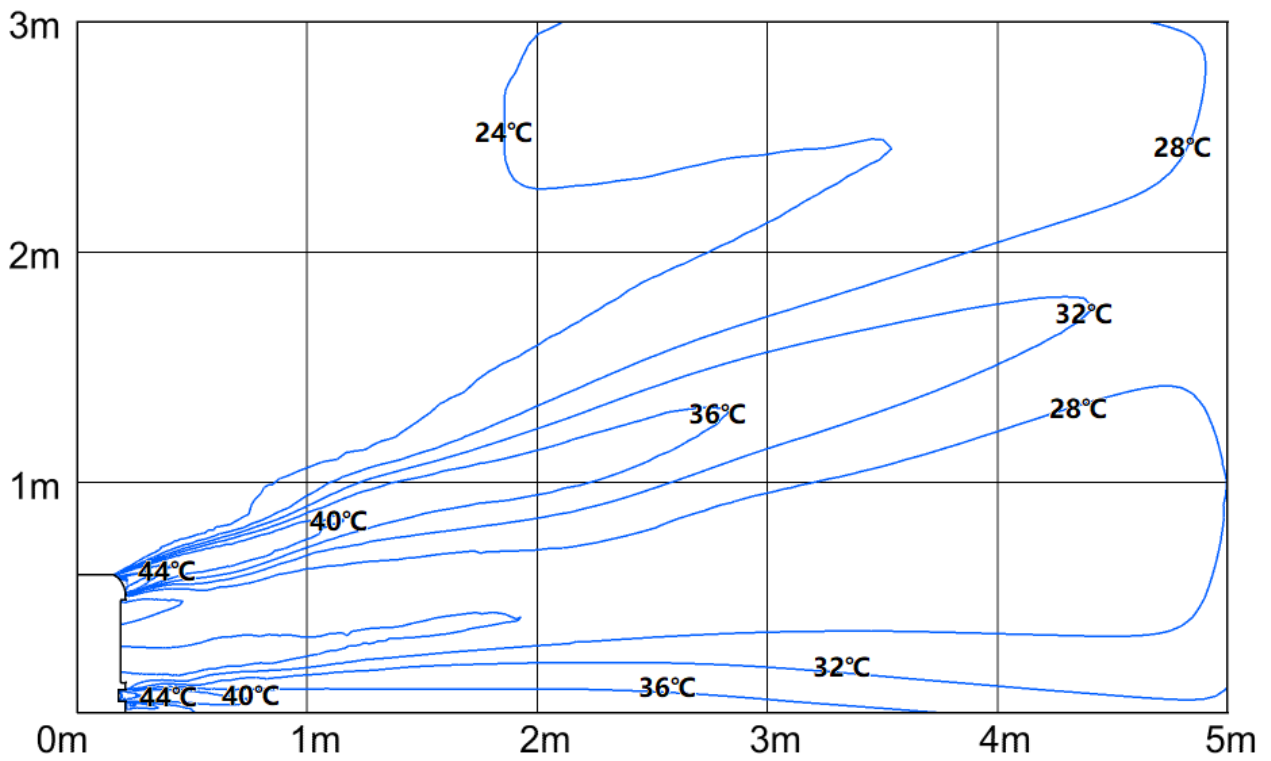



## 8. Noise Criterion Curves

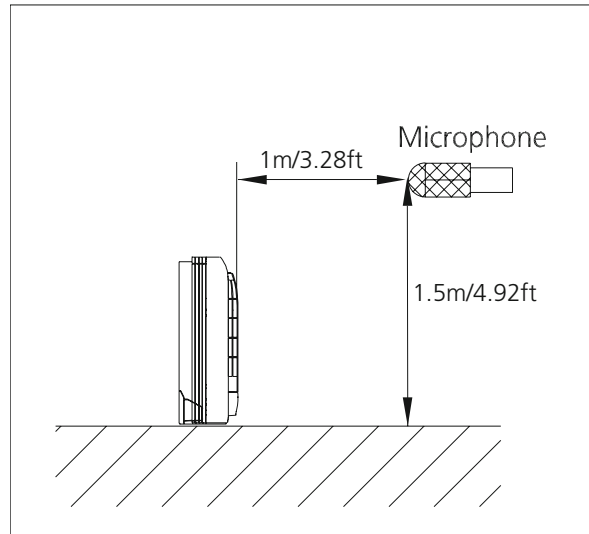

Notes:

- Sound measured at 1m/3.28 away from the unit and 1.5m/4.92ft away from the ground.
- Data is valid at free field condition
- Data is valid at nominal operation condition
- Reference acoustic pressure  $0\text{dB} = 20\mu\text{Pa}$
- Sound level will vary depending on a range of factors such as the construction -(acoustic absorption coefficient) of particular room in which the equipment is installed.
- The operating conditions are assumed to be standard.

MFA2U-12HRFN1-MW5W

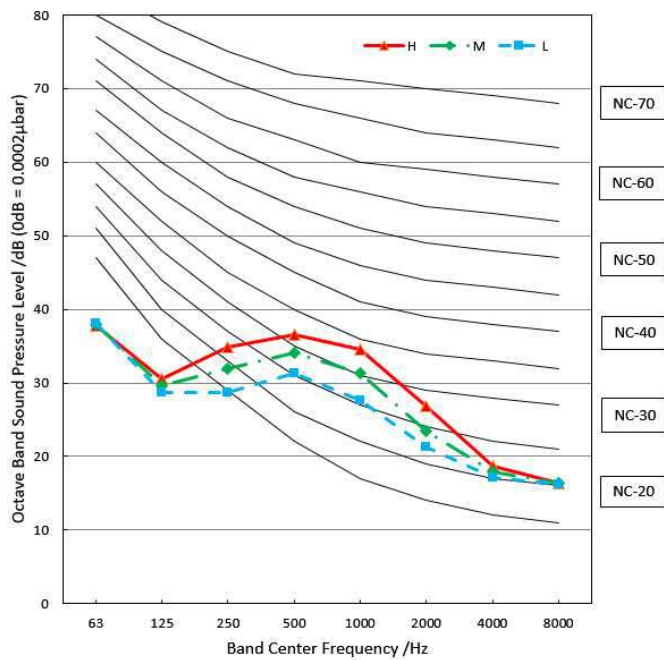

MFA2U-16HRFN1-MV0W

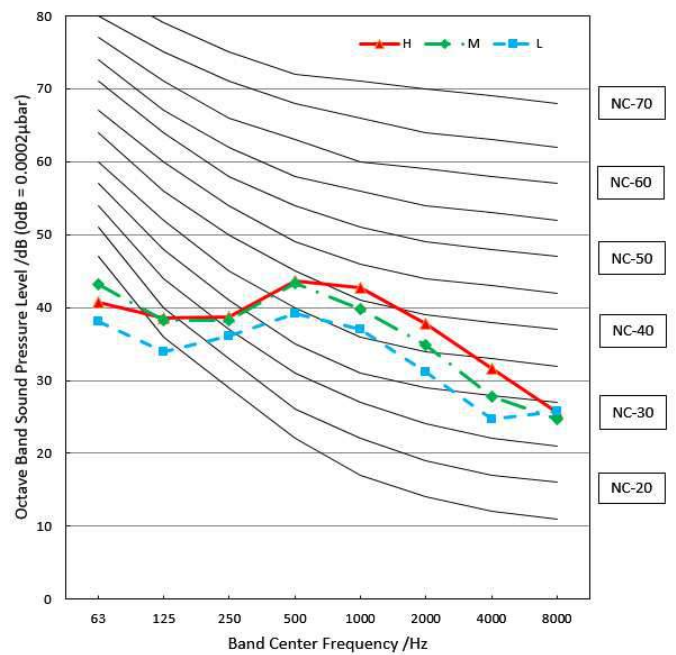

## 9. Electrical Characteristics

Capacity (Btu/h)		9k/12k	9k/12k hyper Heat	18k	18k hyper Heat
Power (Outdoor)	Phase	1	1	1	1
	Frequency And Volt	208/230V,60Hz			
Max Fuse	Indoor unit(A)	15	15	15	15
	Outdoor unit(A)	15	15	30	25
Outdoor Unit Power Wire	Line quantity	3	3	3	3
	Line diameter(AWG)	14/2.5mm <sup>2</sup>	14/2.5mm <sup>2</sup>	14/2.5mm <sup>2</sup>	12/4.0mm <sup>2</sup>
Outdoor-indoor Connection Wire	Line quantity	4	4	4	4
	Line diameter(AWG)	16/1.5mm <sup>2</sup>	16/1.5mm <sup>2</sup>	16/1.5mm <sup>2</sup>	16/1.5mm <sup>2</sup>

## 10. Electrical Wiring Diagrams

IDU Model	IDU Wiring Diagram
MFA2U-12HRFN1-MW5W	16022700003488
MFA2U-16HRFN1-MV0W	

Abbreviation	Paraphrase
Y/G	Yellow-Green Conductor
L	LIVE
N	NEUTRAL
TO CCM Comm.Bus	Central Controller
T1	Indoor Room Temperature
T2	Coil Temperature of Indoor Heat Exchanger

Indoor unit wiring diagram:16022700003488

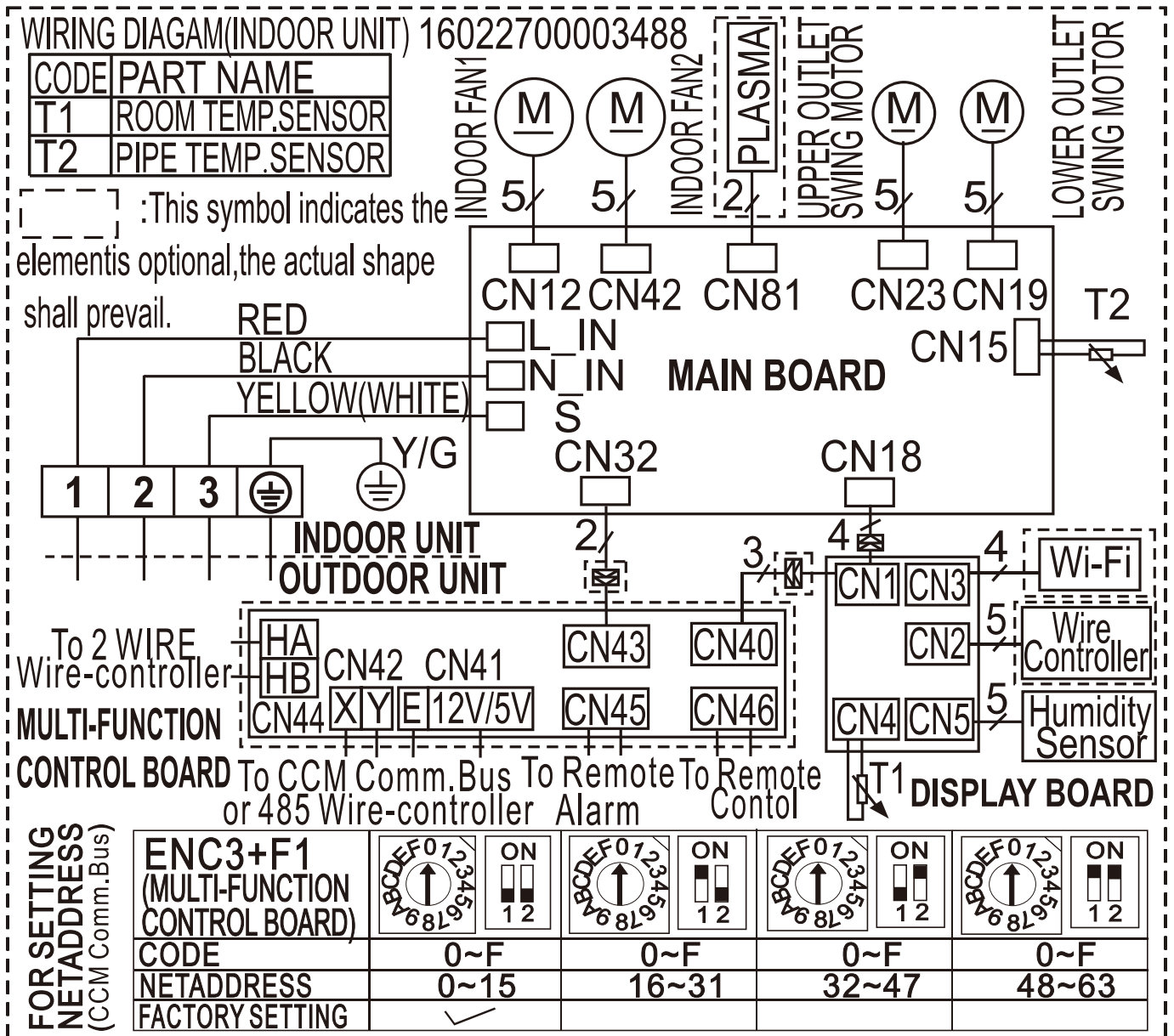

---

# Outdoor Unit

## Contents

1.	Dimensional Drawings .....	2
2.	Service Place.....	18
3.	Capacity Correction Factor for Height Difference .....	19
4.	Noise Criterion Curves.....	25
5.	Refrigerant Cycle Diagrams .....	27
6.	Electrical Wiring Diagrams.....	29

---

## 1. Dimensional Drawings

Please check the corresponding dimensional drawing according to the panel plate.

ODU Model	Panel Plate
MOX230-12HFN1-MV5W	X230
MOX330-12HFN1-MW5W	X330
MOX430-18HFN1-MU0W	X430
MOX430-17HFN1-MT0W	X430

## Panel Plate X230 (Rounded grille 1)

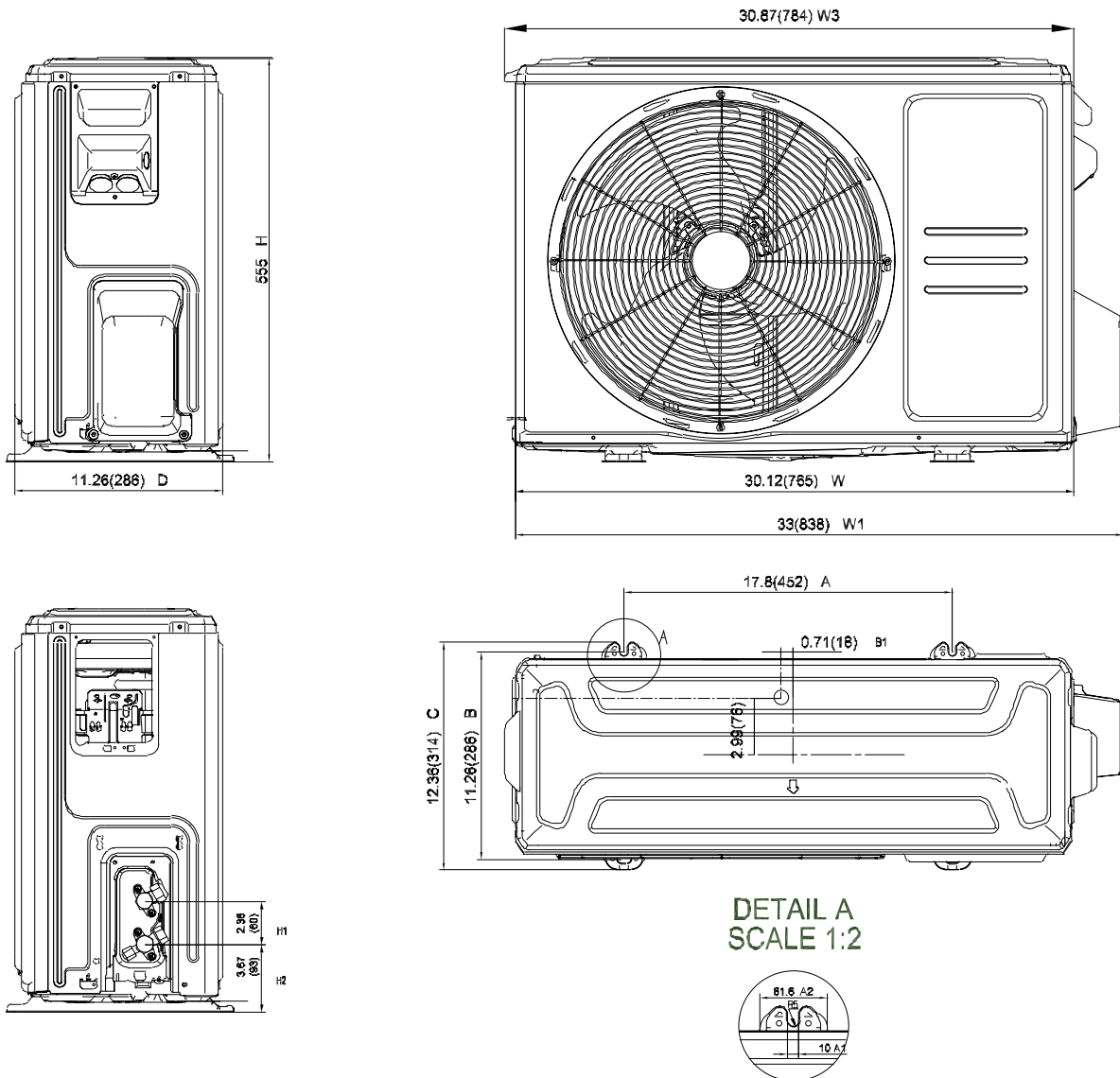

## Panel Plate X230 (Rounded grille 2)

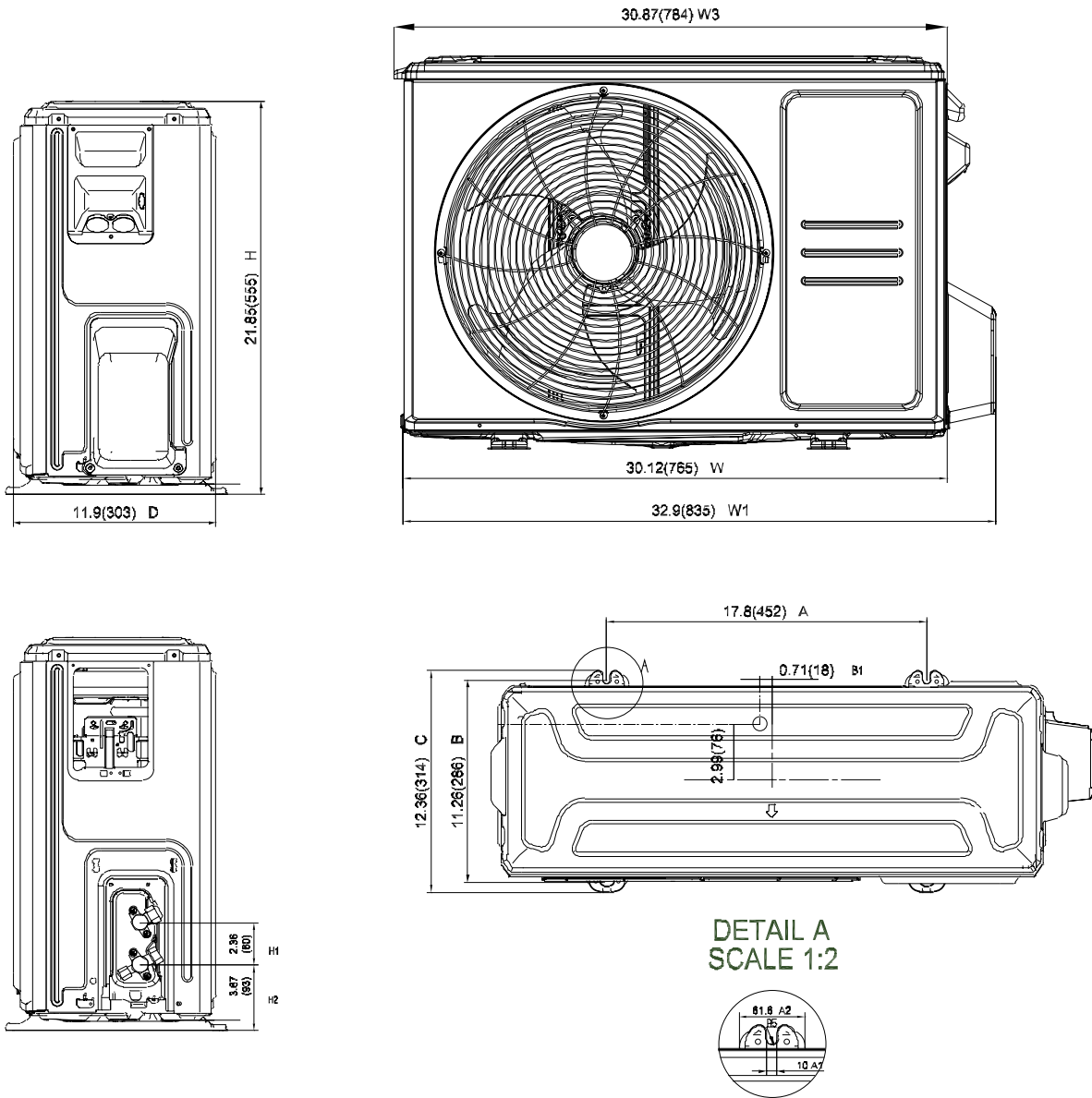

## Panel Plate X230(Square grille)

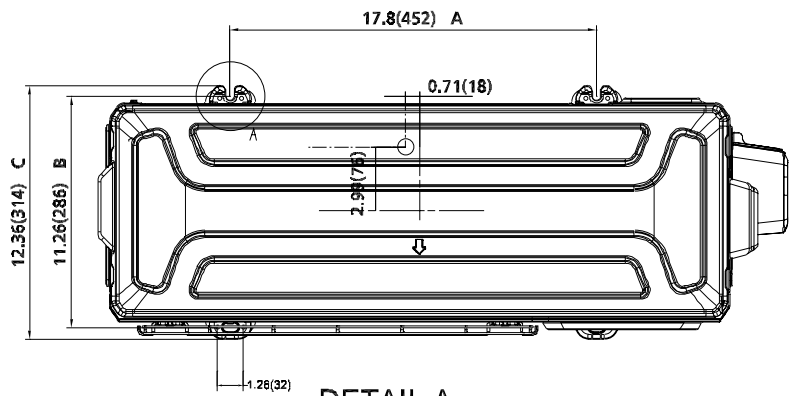
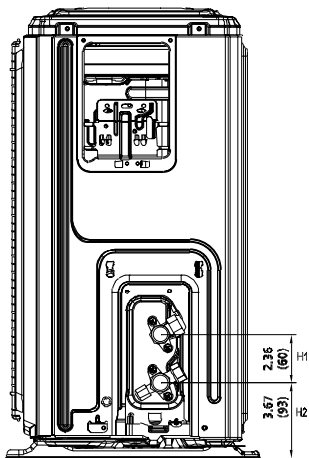
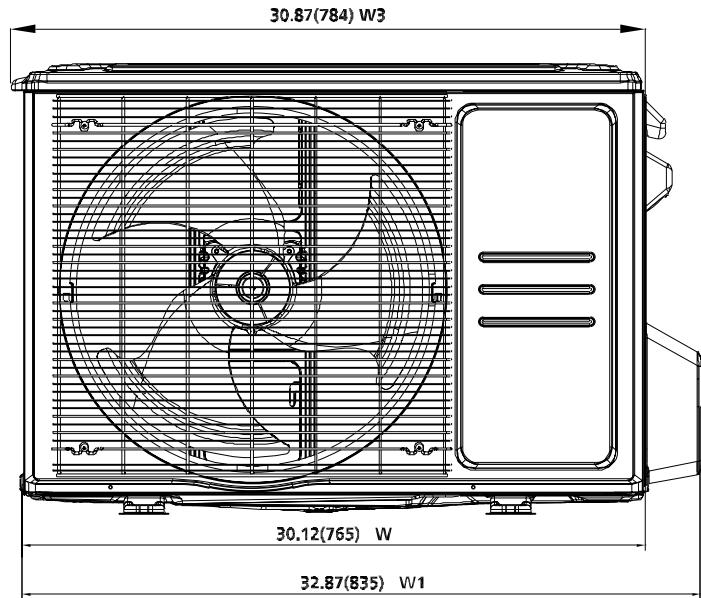
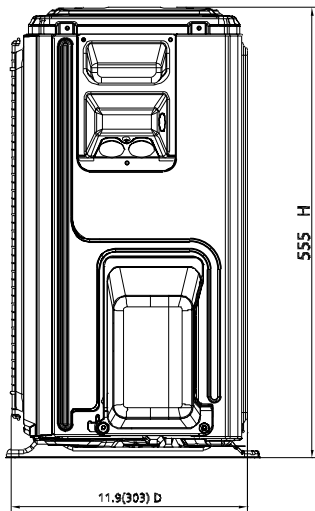

DETAIL A  
SCALE 1:2

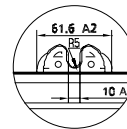



Panel Plate X330(Rounded grille 1)

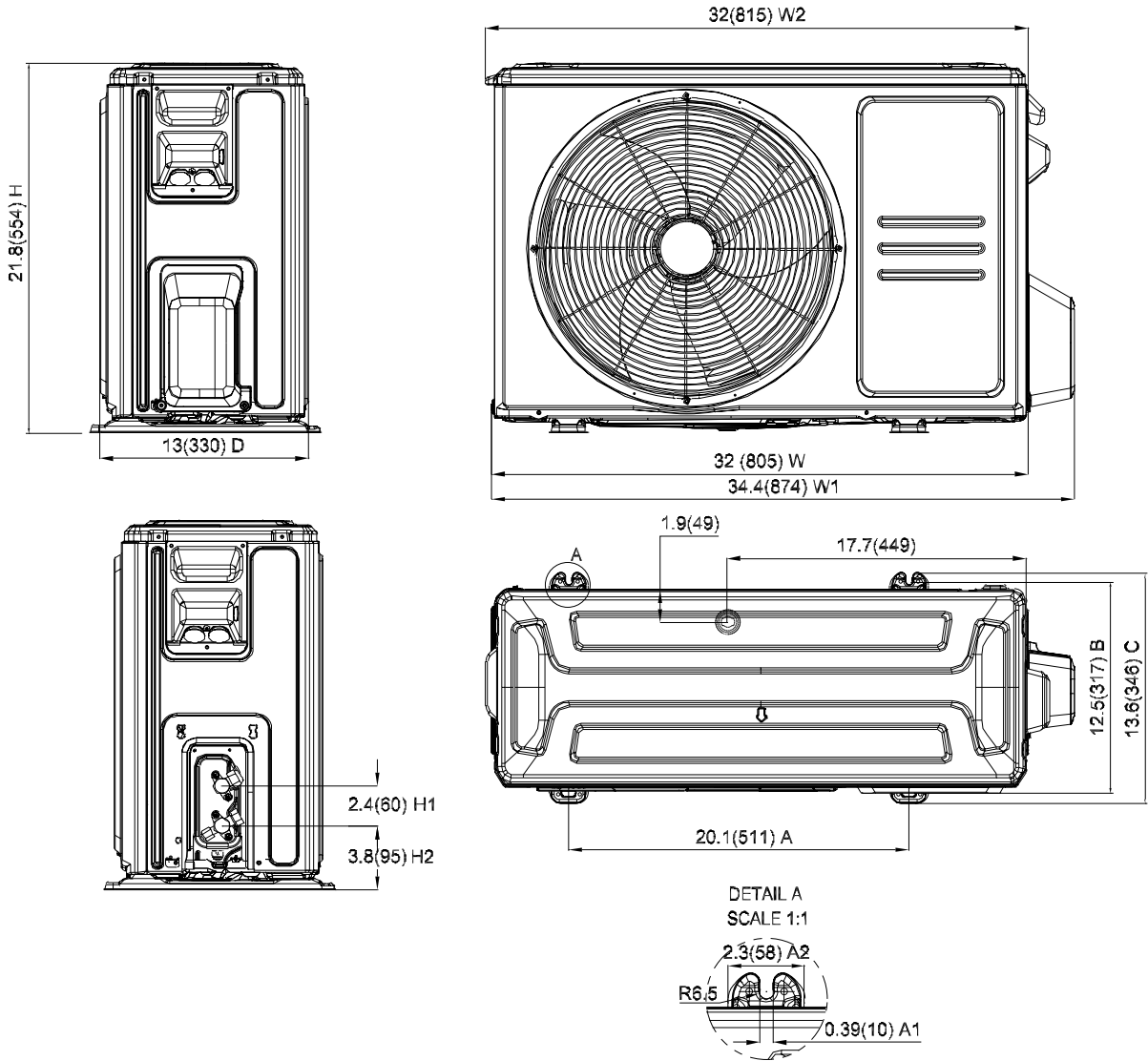

## Panel Plate X330(Rounded grille 2)

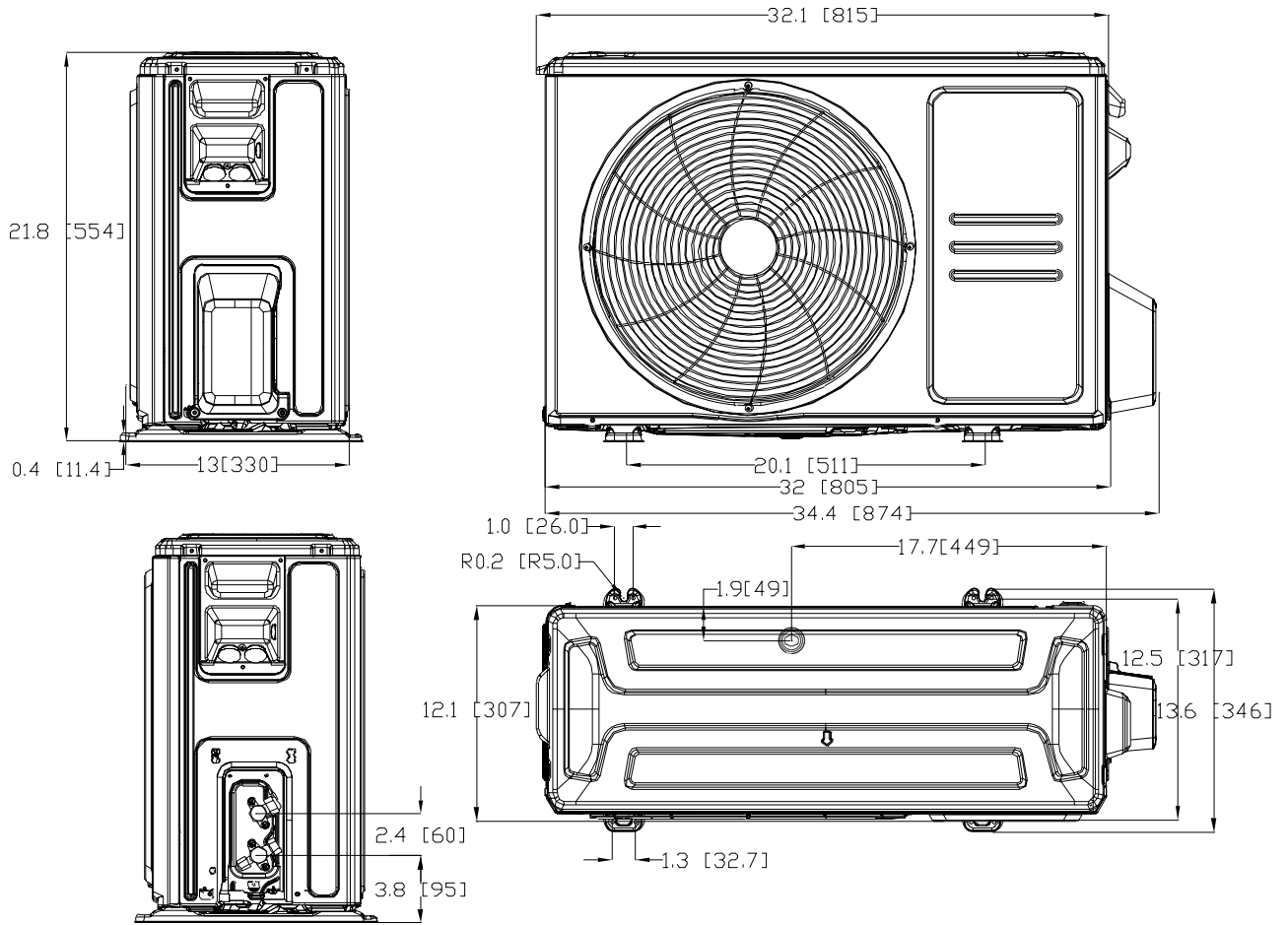

## Panel Plate X330(Square grille)

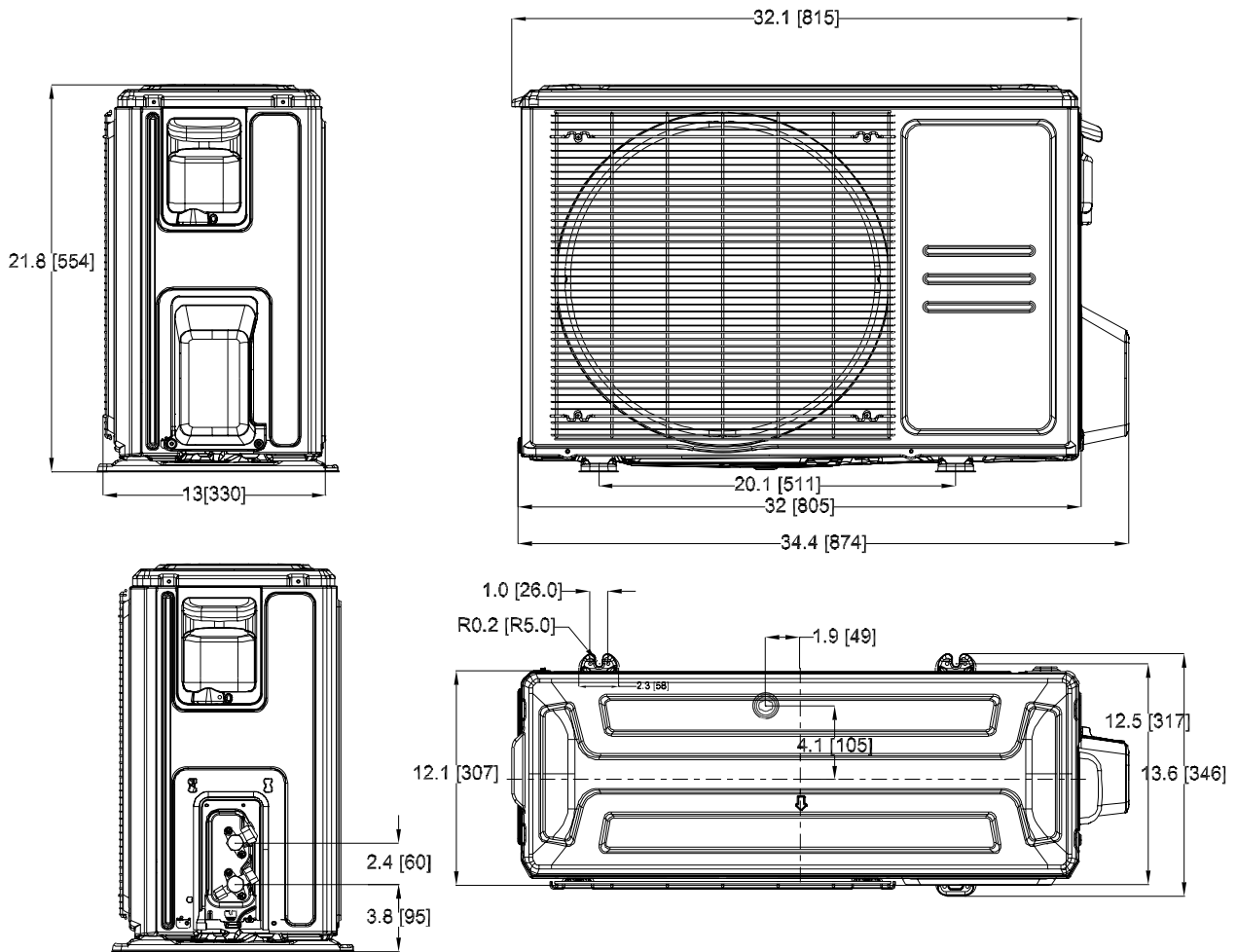

Panel Plate X430(Rounded grille 1)

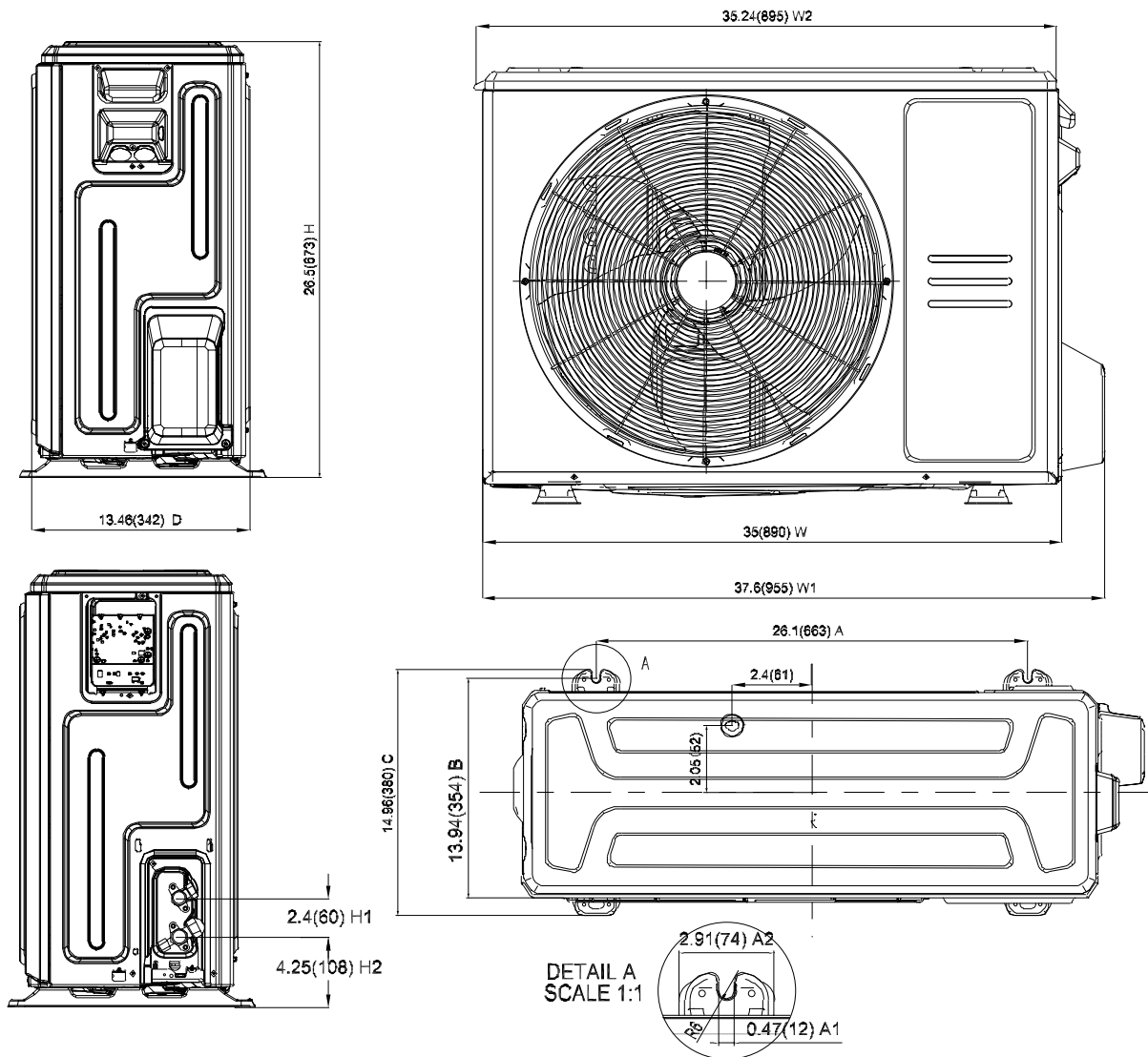

Panel Plate X430(Rounded grille 2)

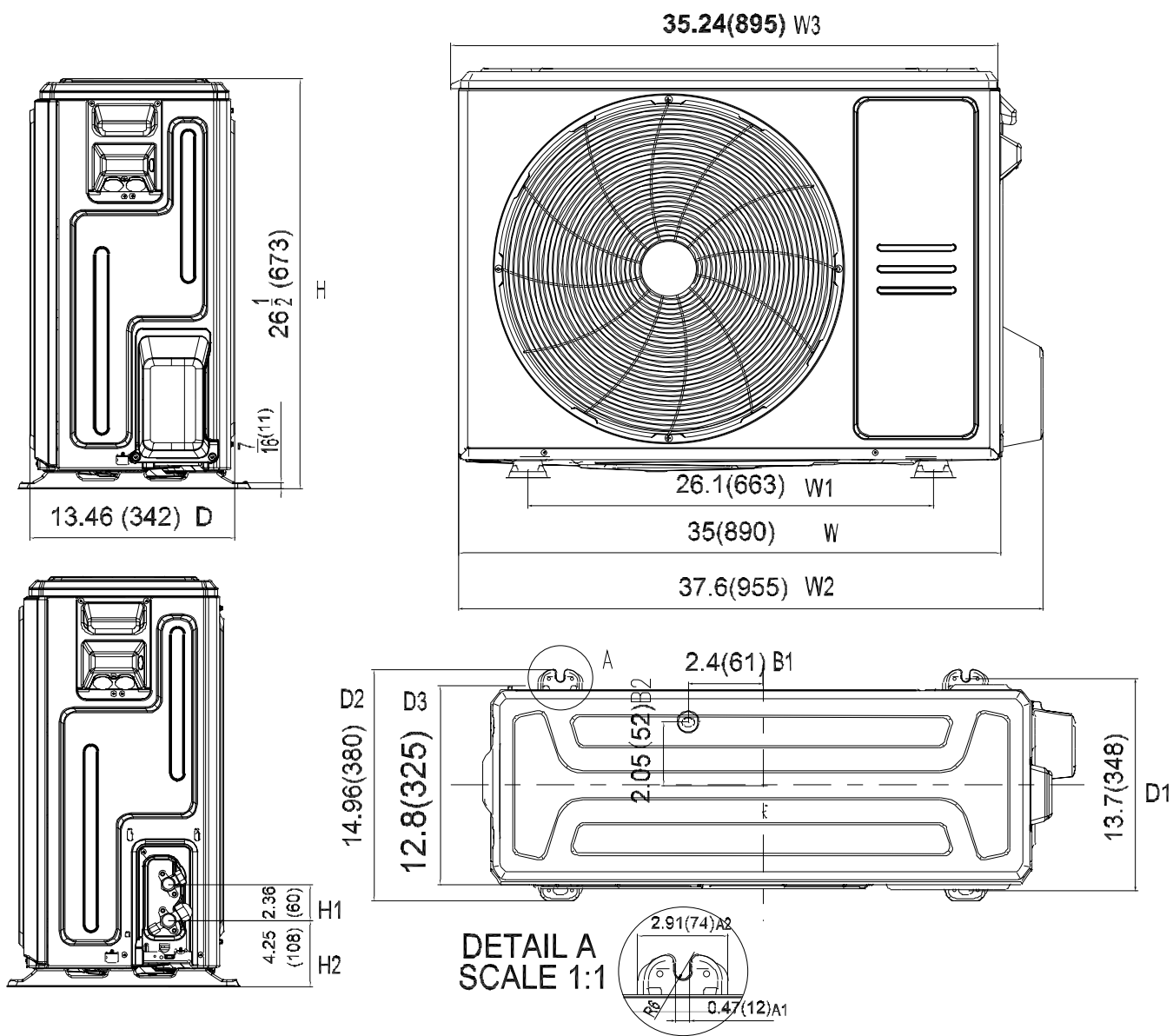

Panel Plate X430(Square grille)

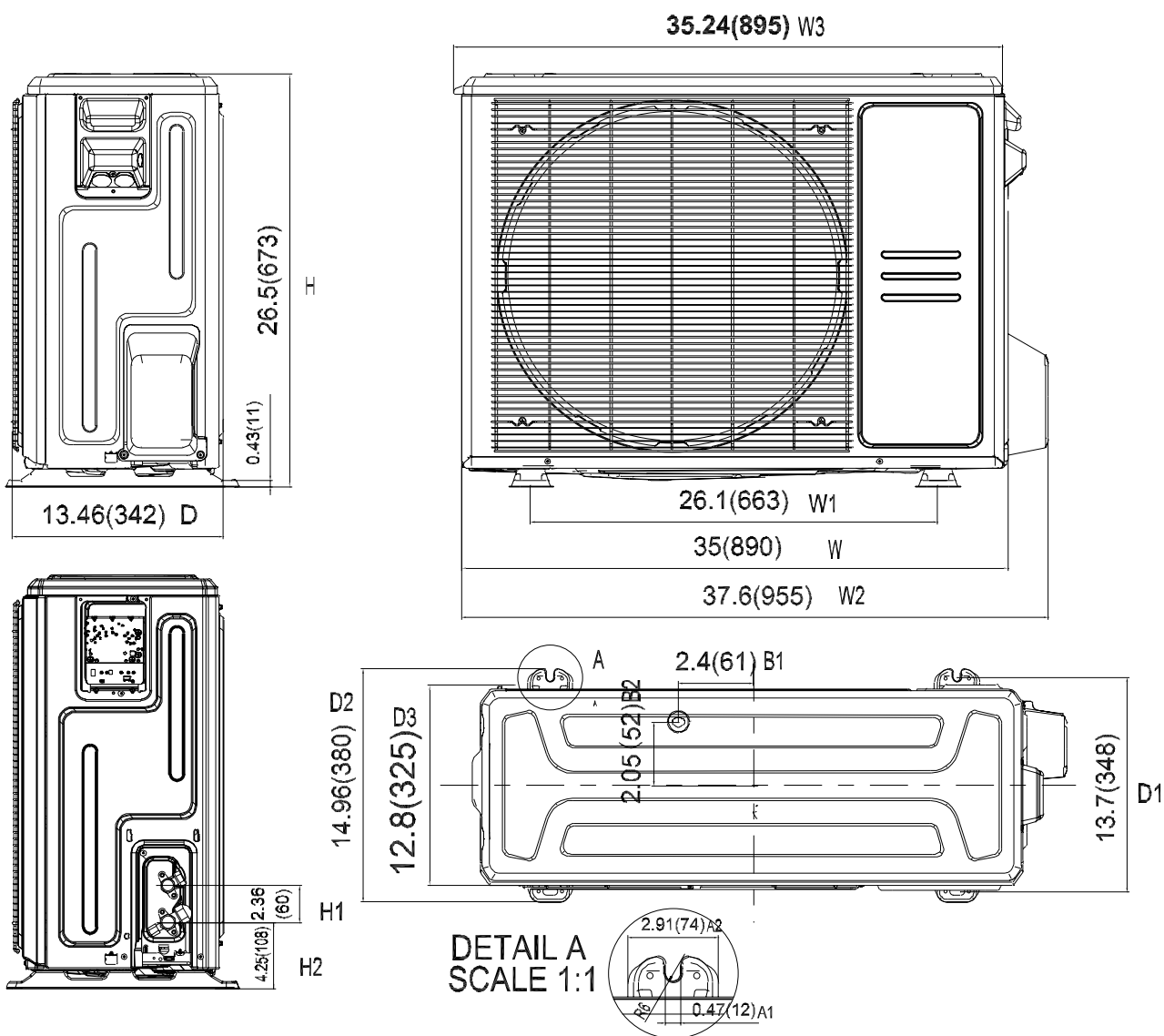

Panel Plate D30(Rounded grille 1)

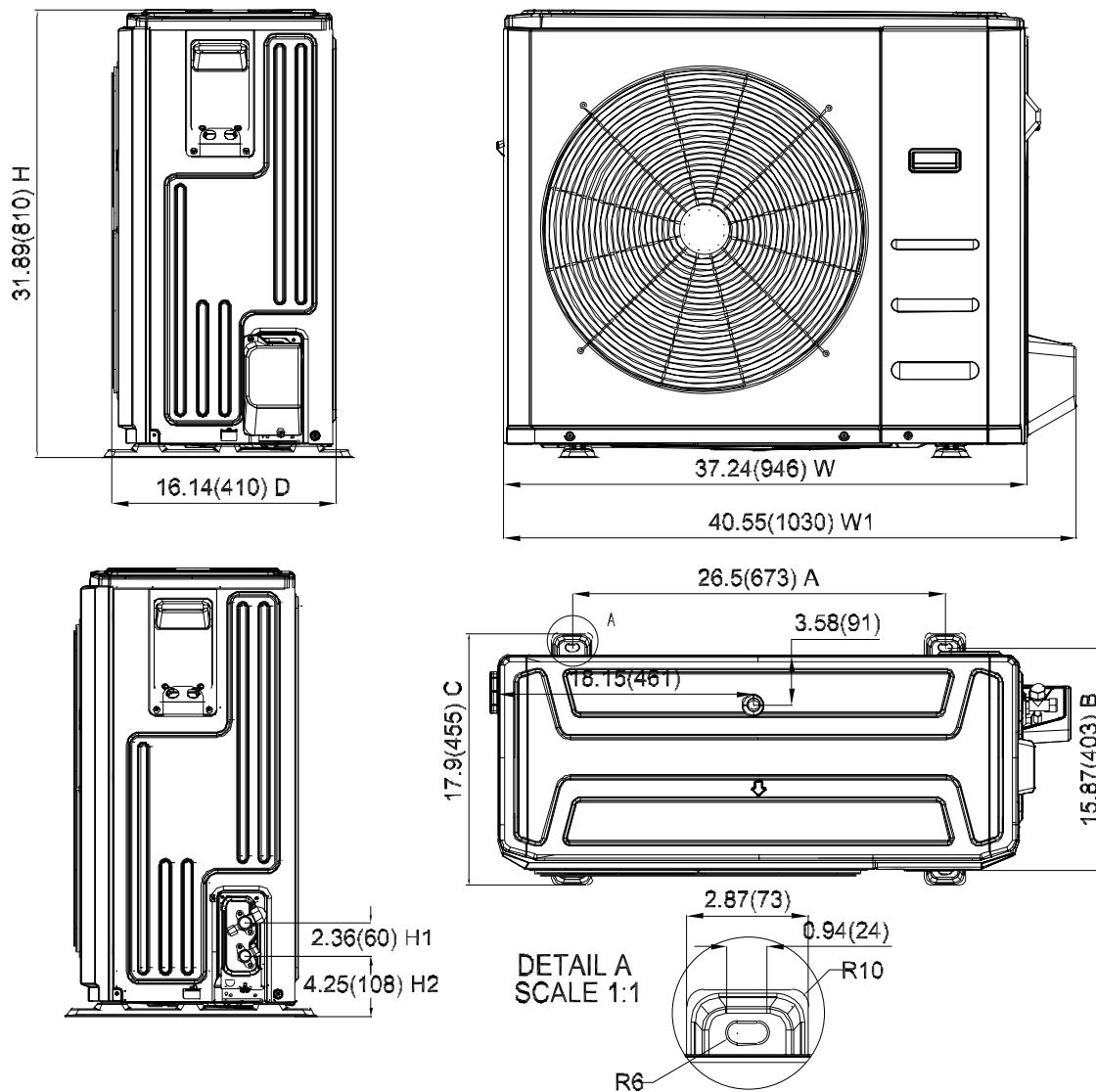

## Panel Plate D30(Rounded grille 2)

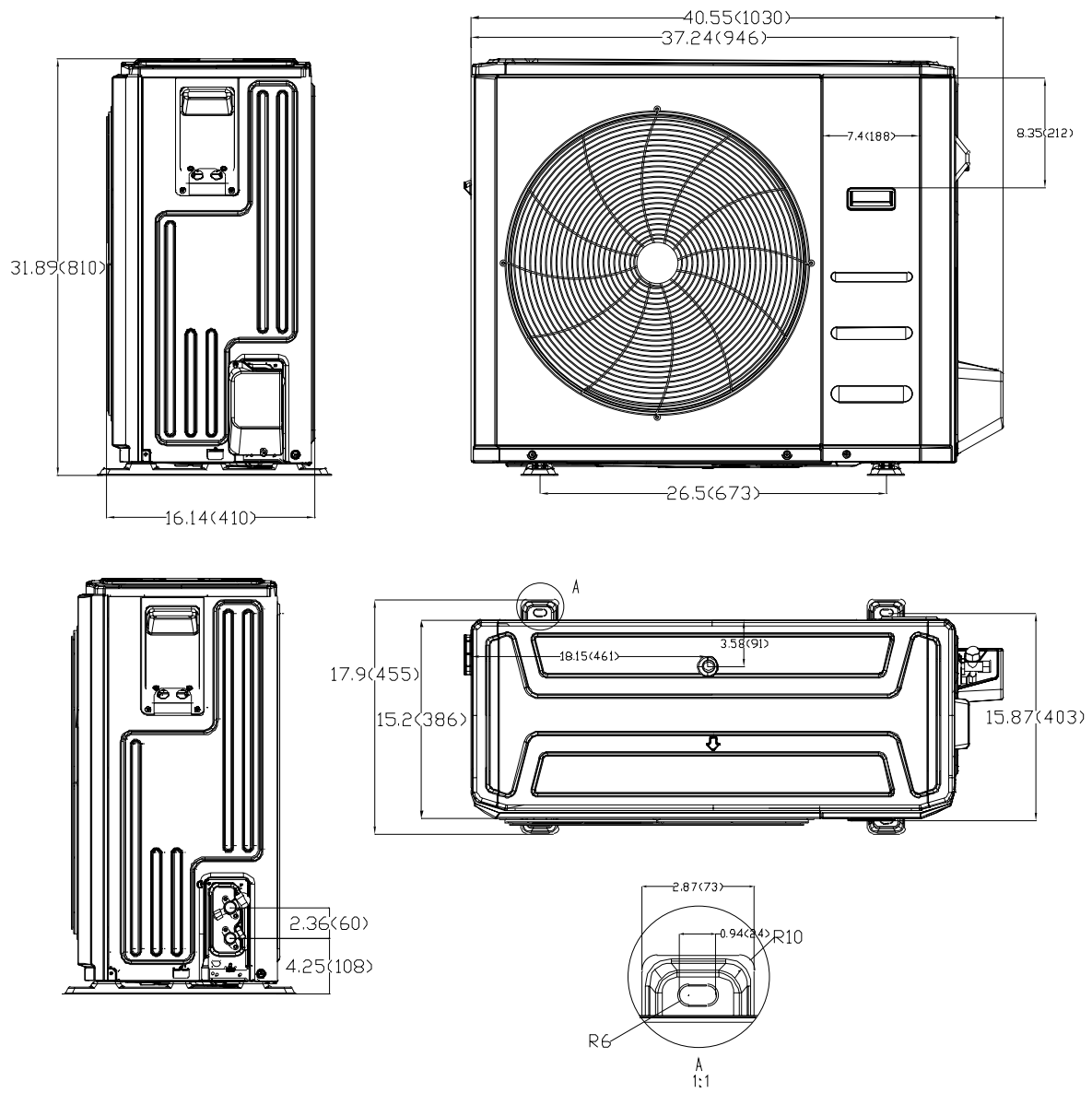



## Panel Plate D30(Square grille)

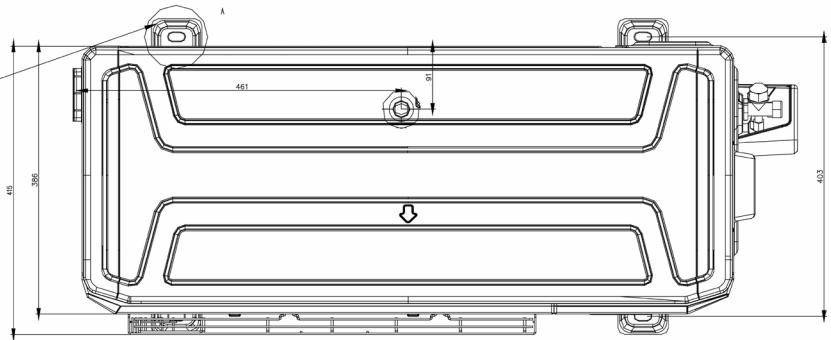
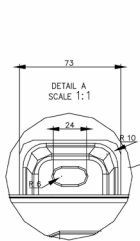
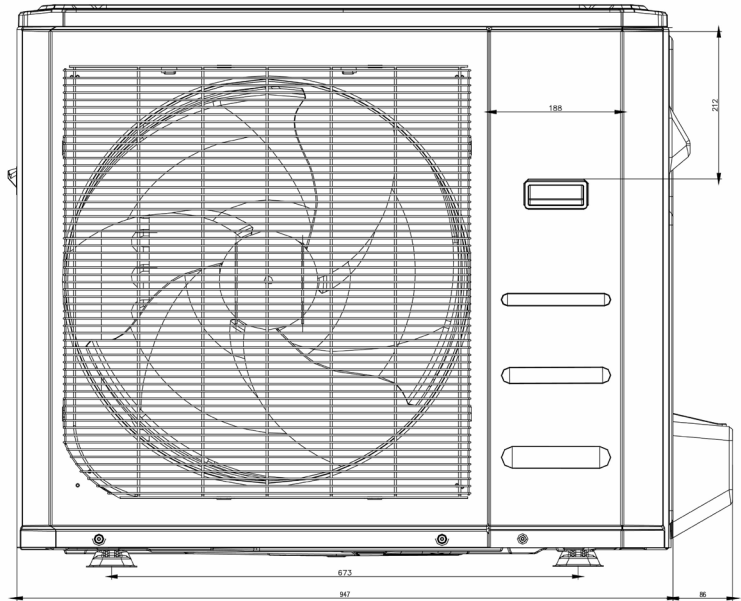
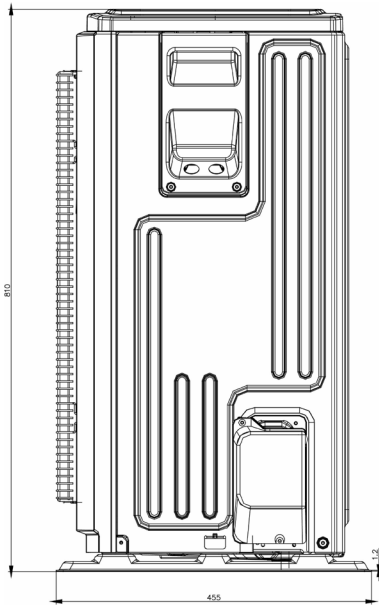

# Panel Plate X630(Square grille)

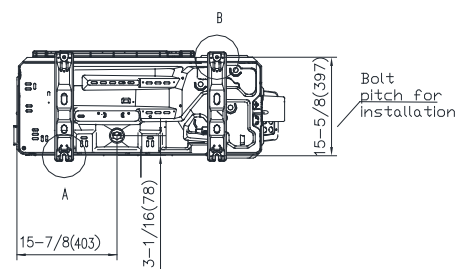
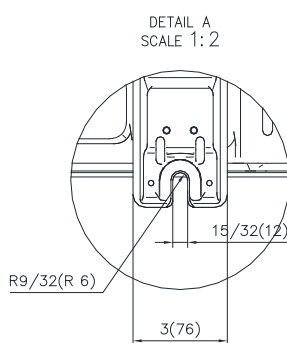
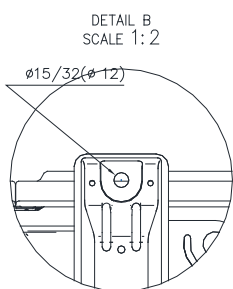
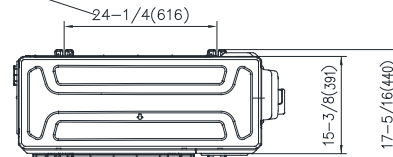
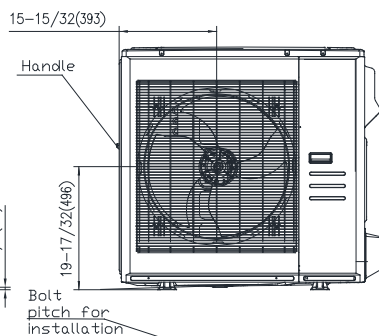
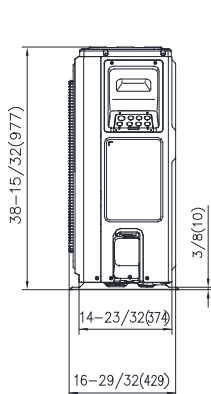
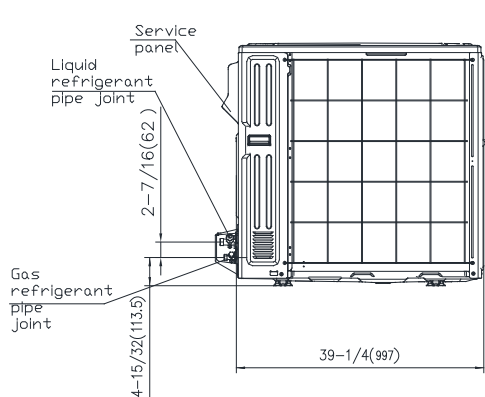

## Panel Plate E30(Square grille)

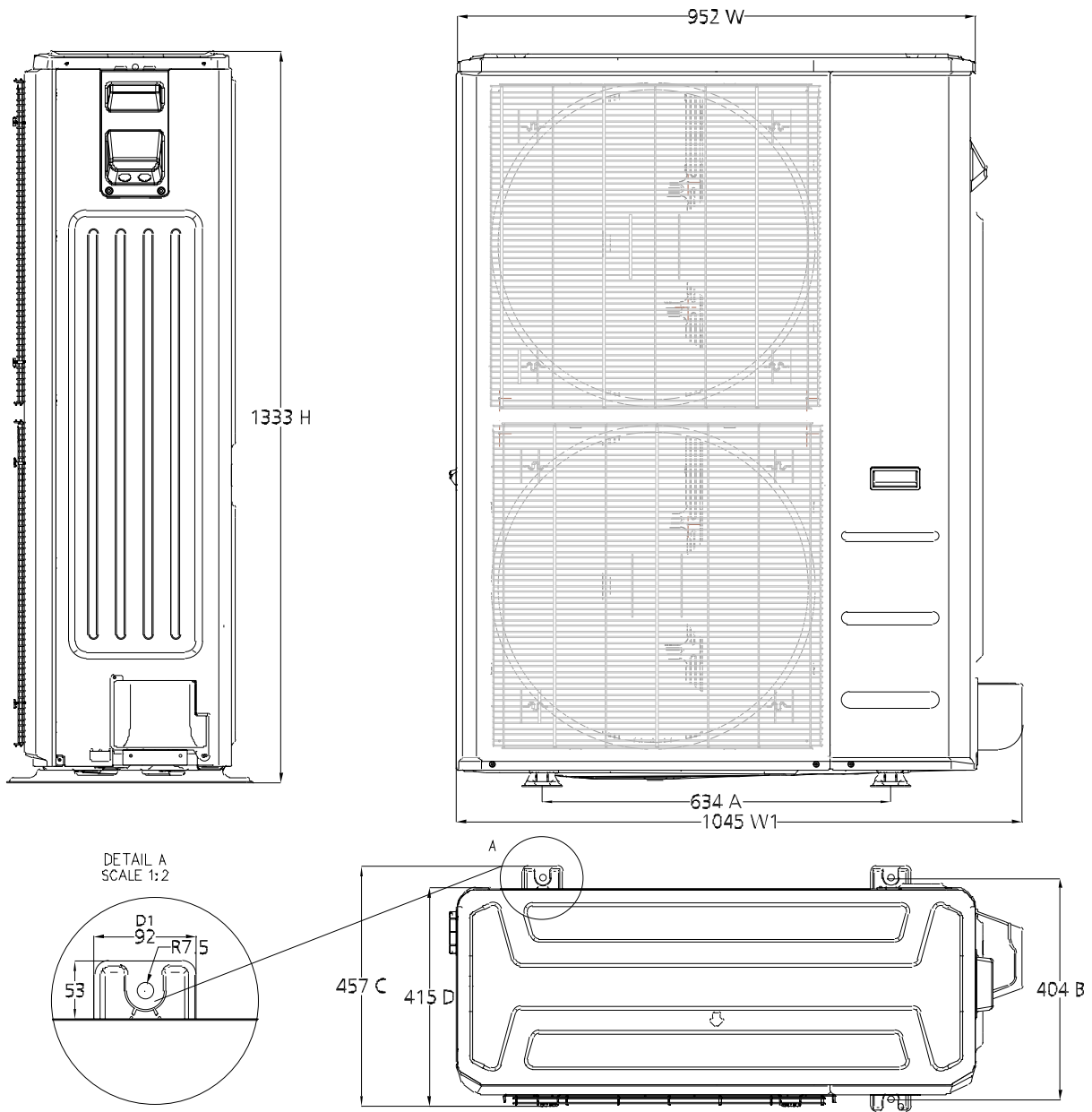

## Panel Plate E30(Rounded grille 1)

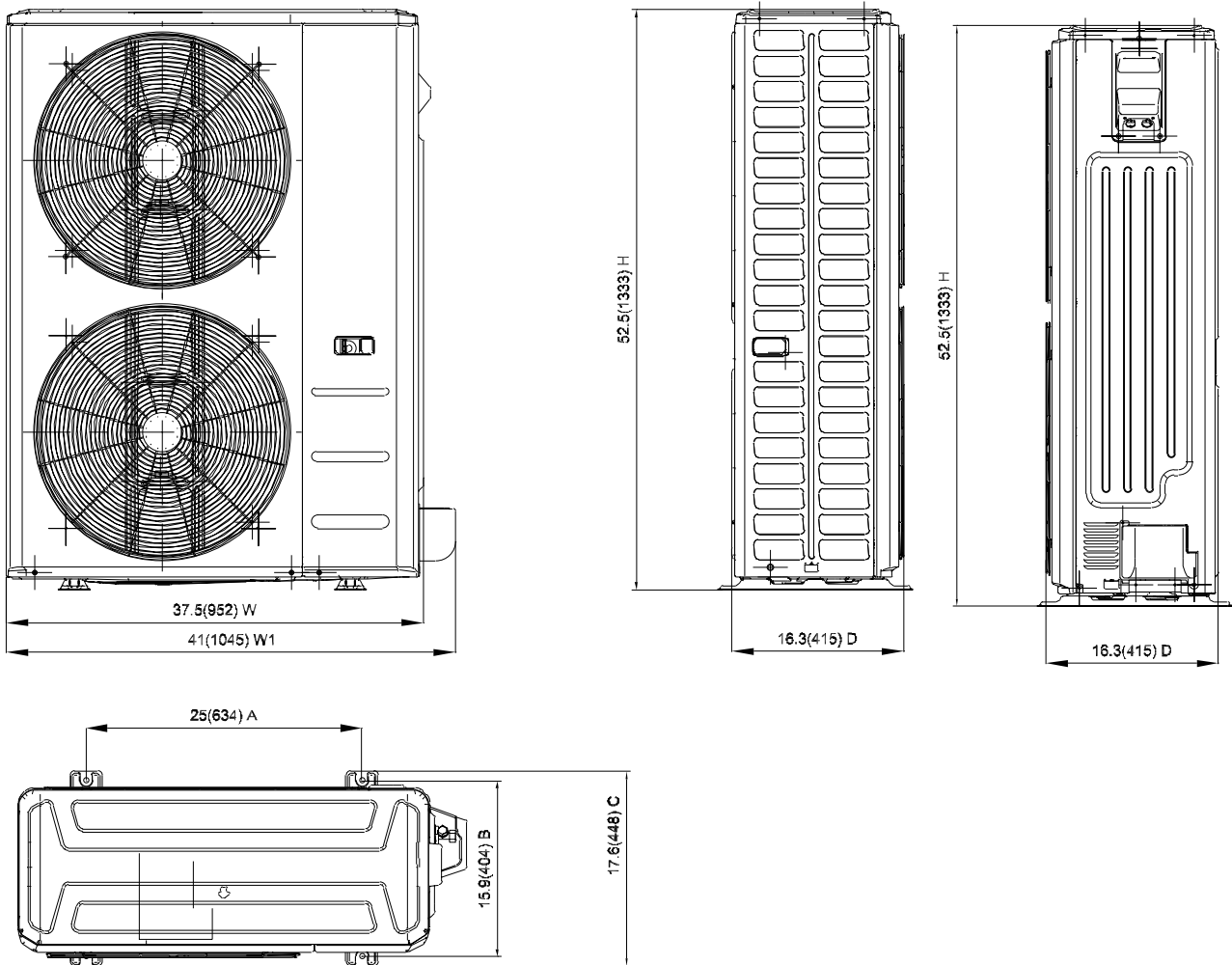

## Panel Plate E30(Rounded grille 2)

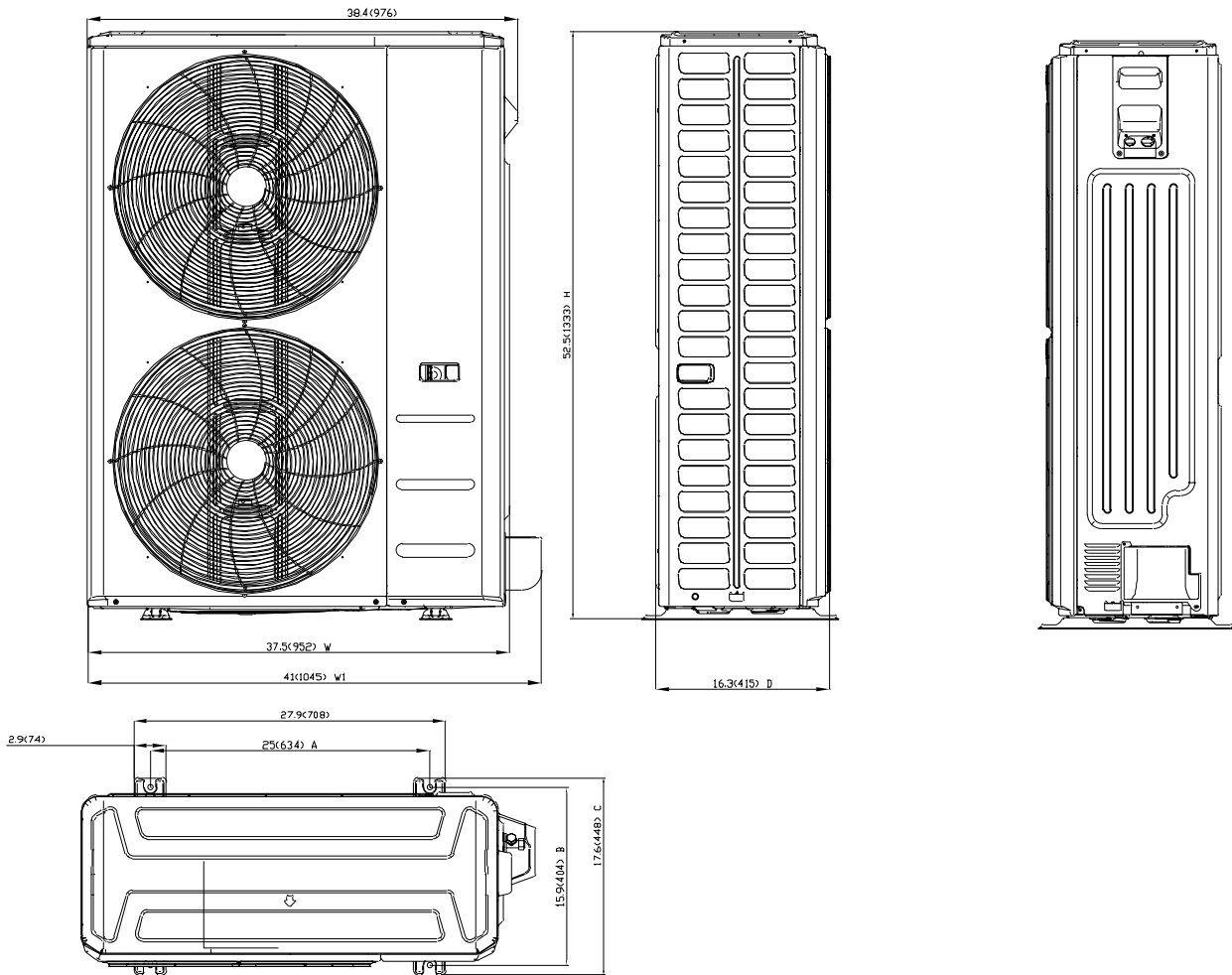

---

## 2. Service Place

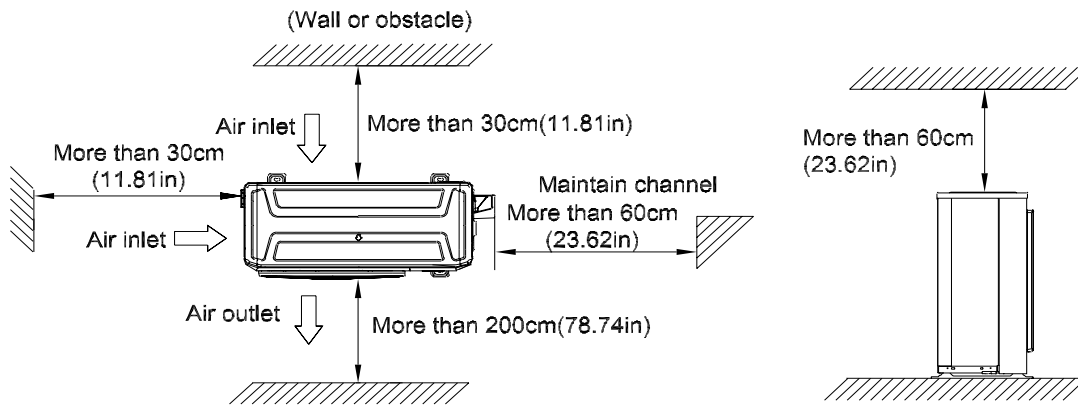

### 3. Capacity Correction Factor for Height Difference

Capacity(Btu/h)		6k~9k		Pipe Length (m/ft)			
		Cooling		7.5/24.6	10/32.8	20/65.6	25/82
Height difference H (m)	Indoor Upper than Outdoor	10/32.8	/	0.969	0.936	0.920	
		5/16.4					0.995
		0	1.000	0.984	0.951	0.934	
	Outdoor Upper than Indoor	-5/-16.4	1.000	0.984	0.951	0.934	
		-10/-32.8	/	0.984	0.951	0.934	
		Heating		7.5/24.6	10/32.8	20/65.6	25/82
Height difference H (m)	Indoor Upper than Outdoor	10/32.8	/	0.989	0.967	0.956	
		5/16.4					1.000
		0	1.000	0.989	0.967	0.956	
	Outdoor Upper than Indoor	-5/-16.4	0.992	0.981	0.959	0.948	
		-10/-32.8	/	0.973	0.952	0.941	

Capacity(Btu/h)		12k		Pipe Length (m/ft)			
		Cooling		7.5/24.6	10/32.8	20/65.6	25/82
Height difference H (m)	Indoor Upper than Outdoor	10/32.8	/	0.974	0.953	0.942	
		5/16.4					0.995
		0	1.000	0.989	0.967	0.956	
	Outdoor Upper than Indoor	-5/-16.4	1.000	0.989	0.967	0.956	
		-10/-32.8	/	0.989	0.967	0.956	
		Heating		7.5/24.6	10/32.8	20/65.6	25/82
Height difference H (m)	Indoor Upper than Outdoor	10/32.8	/	0.994	0.981	0.974	
		5/16.4					1.000
		0	1.000	0.994	0.981	0.974	
	Outdoor Upper than Indoor	-5/-16.4	0.992	0.986	0.973	0.966	
		-10/-32.8	/	0.978	0.965	0.958	

Capacity(Btu/h)		18k		Pipe Length (m/ft)				
		Cooling		7.5/24.6	10/32.8	20/65.6	30/98.4	
Height difference H (m)	Indoor Upper than Outdoor	20/65.6	/	0.941	0.919			
		10/32.8				0.974	0.951	0.928
		5/16.4				0.995	0.983	0.960
		0	1.000	0.988	0.965	0.942		
	Outdoor Upper than Indoor	-5/-16.4	1.000	0.988	0.965	0.942		
		-10/-32.8	/	0.988	0.965	0.942		
		-20/-65.6	/	0.965	0.942			

Capacity(Btu/h)	18k		Pipe Length (m/ft)			
Heating			7.5/24.6	10/32.8	20/65.6	30/98.4
Height difference H (m)	Indoor Upper than Outdoor	20/65.6			0.987	0.978
		10/32.8		0.996	0.987	0.978
		5/16.4	1.000	0.996	0.987	0.978
	0		1.000	0.996	0.987	0.978
	Outdoor Upper than Indoor	-5/-16.4	0.992	0.988	0.979	0.970
		-10/-32.8		0.980	0.971	0.962
		-20/-65.6			0.963	0.955

Capacity (Btu/h)	24k		Pipe Length (m/ft)					
Cooling			7.5/24.6	10/32.8	20/65.6	30/98.4	40/131.2	50/164
Height difference H (m)	Indoor Upper than Outdoor	25/82				0.917	0.898	0.879
		20/65.6			0.946	0.926	0.907	0.887
		10/32.8		0.975	0.955	0.936	0.916	0.896
		5/16.4	0.995	0.985	0.965	0.945	0.925	0.905
	0		1.000	0.990	0.970	0.950	0.930	0.910
	Outdoor Upper than Indoor	-5/-16.4	1.000	0.990	0.970	0.950	0.930	0.910
		-10/-32.8		0.990	0.970	0.950	0.930	0.910
		-20/-65.6			0.970	0.950	0.930	0.910
-25/-82					0.950	0.930	0.910	

Heating			7.5/24.6	10/32.8	20/65.6	30/98.4	40/131.2	50/164
Height difference H (m)	Indoor Upper than Outdoor	25/82				0.984	0.978	0.972
		20/65.6			0.991	0.984	0.978	0.972
		10/32.8		0.997	0.991	0.984	0.978	0.972
		5/16.4	1.000	0.997	0.991	0.984	0.978	0.972
	0		1.000	0.997	0.991	0.984	0.978	0.972
	Outdoor Upper than Indoor	-5/-16.4	0.992	0.989	0.983	0.977	0.970	0.964
		-10/-32.8		0.981	0.975	0.969	0.963	0.957
		-20/-65.6			0.967	0.961	0.955	0.949
-25/-82					0.953	0.947	0.941	



Capacity (Btu/h)	30k		Pipe Length (m/ft)					
Cooling			7.5/24.6	10/32.8	20/65.6	30/98.4	40/131.2	50/164
Height difference H (m)	Indoor Upper than Outdoor	25/82				0.891	0.862	0.832
		20/65.6			0.930	0.900	0.871	0.841
		10/32.8		0.970	0.940	0.910	0.879	0.849
		5/16.4	0.995	0.980	0.949	0.919	0.888	0.858
		0	1.000	0.985	0.954	0.923	0.893	0.862
	Outdoor Upper than Indoor	-5/-16.4	1.000	0.985	0.954	0.923	0.893	0.862
		-10/-32.8		0.985	0.954	0.923	0.893	0.862
		-20/-65.6			0.954	0.923	0.893	0.862
-25/-82					0.923	0.893	0.862	
Heating			7.5/24.6	10/32.8	20/65.6	30/98.4	40/131.2	50/164
Height difference H (m)	Indoor Upper than Outdoor	25/82				0.961	0.945	0.929
		20/65.6			0.976	0.961	0.945	0.929
		10/32.8		0.992	0.976	0.961	0.945	0.929
		5/16.4	1.000	0.992	0.976	0.961	0.945	0.929
		0	1.000	0.992	0.976	0.961	0.945	0.929
	Outdoor Upper than Indoor	-5/-16.4	0.992	0.984	0.969	0.953	0.937	0.922
		-10/-32.8		0.976	0.961	0.945	0.930	0.914
		-20/-65.6			0.953	0.938	0.922	0.907
-25/-82					0.930	0.915	0.900	

Capacity (Btu/h)	36k		Pipe Length (m/ft)					
Cooling			7.5/24.6	15/49.2	25/82	35/114.8	50/164	65/213.3
Height difference H (m)	Indoor Upper than Outdoor	30/98.4				0.889	0.850	0.812
		20/65.6			0.924	0.898	0.859	0.820
		10/32.8		0.959	0.933	0.907	0.868	0.828
		5/16.4	0.995	0.969	0.942	0.916	0.876	0.837
		0	1.000	0.974	0.947	0.921	0.881	0.841
	Outdoor Upper than Indoor	-5/-16.4	1.000	0.974	0.947	0.921	0.881	0.841
		-10/-32.8		0.974	0.947	0.921	0.881	0.841
		-20/-65.6			0.947	0.921	0.881	0.841
-30/-98.4					0.921	0.881	0.841	
Heating			7.5/24.6	15/49.2	25/82	35/114.8	50/164	65/213.3
Height difference H (m)	Indoor Upper than Outdoor	30/98.4				0.964	0.945	0.927
		20/65.6			0.976	0.964	0.945	0.927
		10/32.8		0.988	0.976	0.964	0.945	0.927
		5/16.4	1.000	0.988	0.976	0.964	0.945	0.927
		0	1.000	0.988	0.976	0.964	0.945	0.927
	Outdoor Upper than Indoor	-5/-16.4	0.992	0.980	0.968	0.956	0.938	0.920
		-10/-32.8		0.972	0.960	0.948	0.930	0.912
		-20/-65.6			0.952	0.941	0.923	0.905
-30/-98.4					0.933	0.915	0.898	

Capacity (Btu/h)	48k		Pipe Length (m/ft)					
Cooling			7.5/24.6	15/49.2	25/82	35/114.8	50/164	65/213.3
Height difference H (m)	Indoor Upper than Outdoor	30/98.4				0.884	0.843	0.802
		20/65.6			0.920	0.893	0.852	0.810
		10/32.8		0.957	0.930	0.902	0.860	0.819
		5/16.4	0.995	0.967	0.939	0.911	0.869	0.827
		0	1.000	0.972	0.944	0.916	0.873	0.831
	Outdoor Upper than Indoor	-5/-16.4	1.000	0.972	0.944	0.916	0.873	0.831
		-10/-32.8		0.972	0.944	0.916	0.873	0.831
		-20/-65.6			0.944	0.916	0.873	0.831
		-30/-98.4				0.916	0.873	0.831
	Heating			7.5/24.6	15/49.2	25/82	35/114.8	50/164
Height difference H (m)	Indoor Upper than Outdoor	30/98.4				0.958	0.936	0.915
		20/65.6			0.972	0.958	0.936	0.915
		10/32.8		0.986	0.972	0.958	0.936	0.915
		5/16.4	1.000	0.986	0.972	0.958	0.936	0.915
		0	1.000	0.986	0.972	0.958	0.936	0.915
	Outdoor Upper than Indoor	-5/-16.4	0.992	0.978	0.964	0.950	0.929	0.908
		-10/-32.8		0.970	0.956	0.942	0.921	0.900
		-20/-65.6			0.949	0.935	0.914	0.893
-30/-98.4					0.927	0.907	0.886	

Capacity (Btu/h)	60k		Pipe Length (m/ft)					
Cooling			7.5/24.6	15/49.2	25/82	35/114.8	50/164	65/213.3
Height difference H (m)	Indoor Upper than Outdoor	30/98.4				0.870	0.823	0.775
		20/65.6			0.911	0.879	0.831	0.783
		10/32.8		0.953	0.920	0.888	0.840	0.791
		5/16.4	0.995	0.962	0.930	0.897	0.848	0.799
		0	1.000	0.967	0.934	0.902	0.852	0.803
	Outdoor Upper than Indoor	-5/-16.4	1.000	0.967	0.934	0.902	0.852	0.803
		-10/-32.8		0.967	0.934	0.902	0.852	0.803
		-20/-65.6			0.934	0.902	0.852	0.803
		-30/-98.4				0.902	0.852	0.803
	Heating			7.5/24.6	15/49.2	25/82	35/114.8	50/164
Height difference H (m)	Indoor Upper than Outdoor	30/98.4				0.955	0.932	0.909
		20/65.6			0.970	0.955	0.932	0.909
		10/32.8		0.985	0.970	0.955	0.932	0.909
		5/16.4	1.000	0.985	0.970	0.955	0.932	0.909
		0	1.000	0.985	0.970	0.955	0.932	0.909
	Outdoor Upper than Indoor	-5/-16.4	0.992	0.977	0.962	0.947	0.924	0.902
		-10/-32.8		0.969	0.954	0.939	0.917	0.895
		-20/-65.6			0.947	0.932	0.910	0.887
-30/-98.4					0.924	0.902	0.880	

---

## 4. Noise Criterion Curves

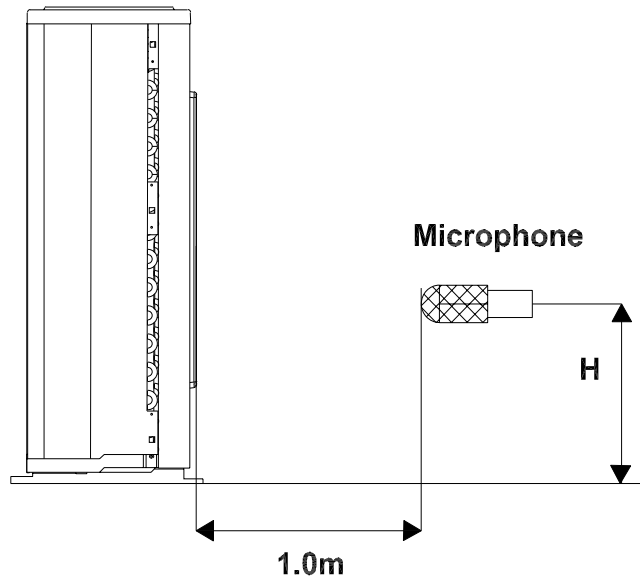

Note:  $H = 0.5 \times$  height of outdoor unit

Notes:

- Sound measured at 1.0m away from the center of the unit.
- Data is valid at free field condition
- Data is valid at nominal operation condition
- Reference acoustic pressure  $OdB=20\mu Pa$
- Sound level will vary depending on arrangement of factors such as the construction (acoustic absorption coefficient) of particular room in which the equipment is installed.
- The operating conditions are assumed to be standard.

MOX230-12HFN1-MV5W

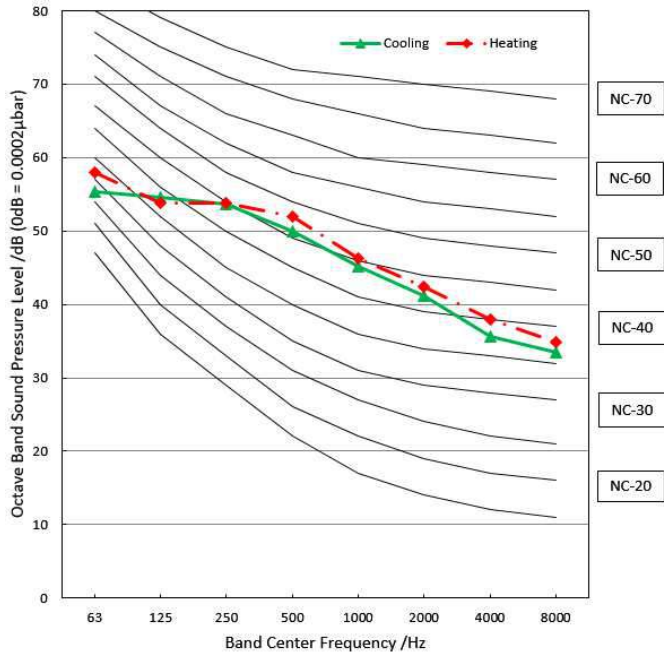

MOX330-12HFN1-MW5W

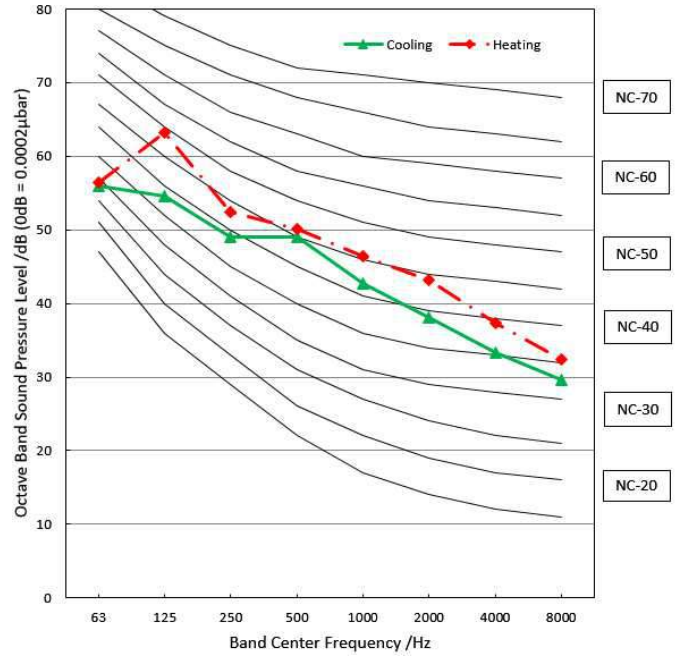

MOX430-17HFN1-MT0W

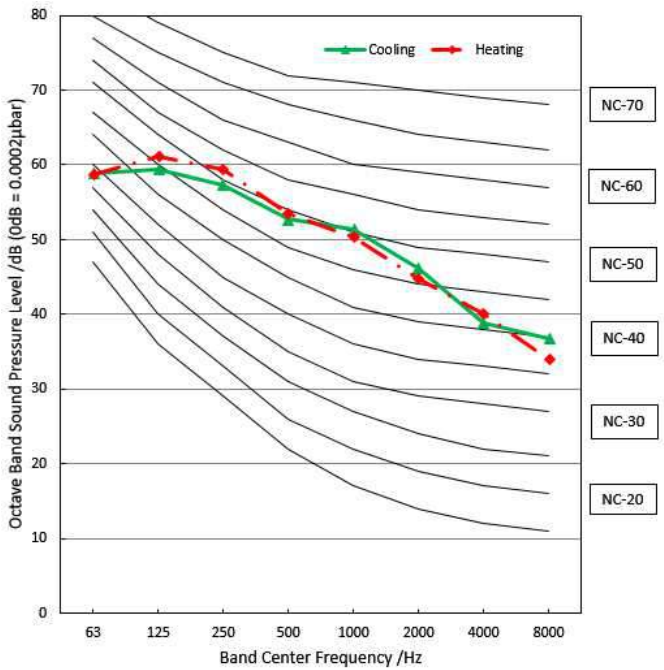

MOX430-18HFN1-MU0W

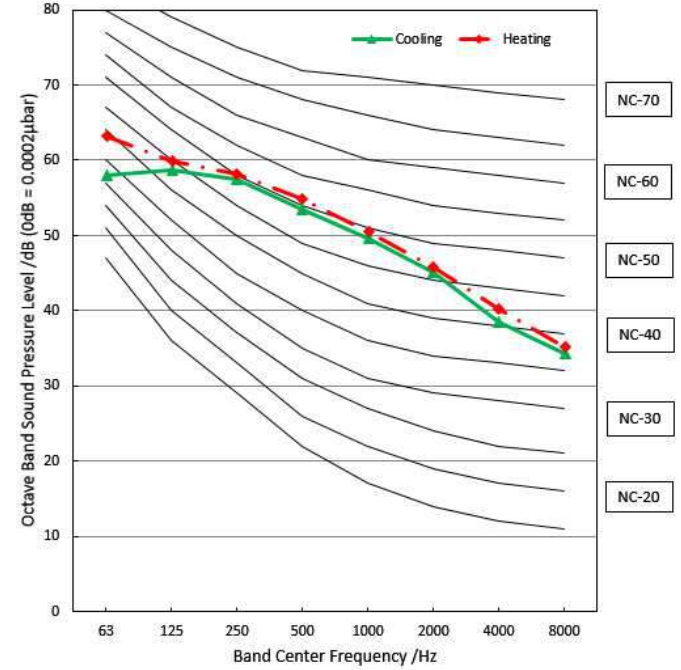

## 5. Refrigerant Cycle Diagrams

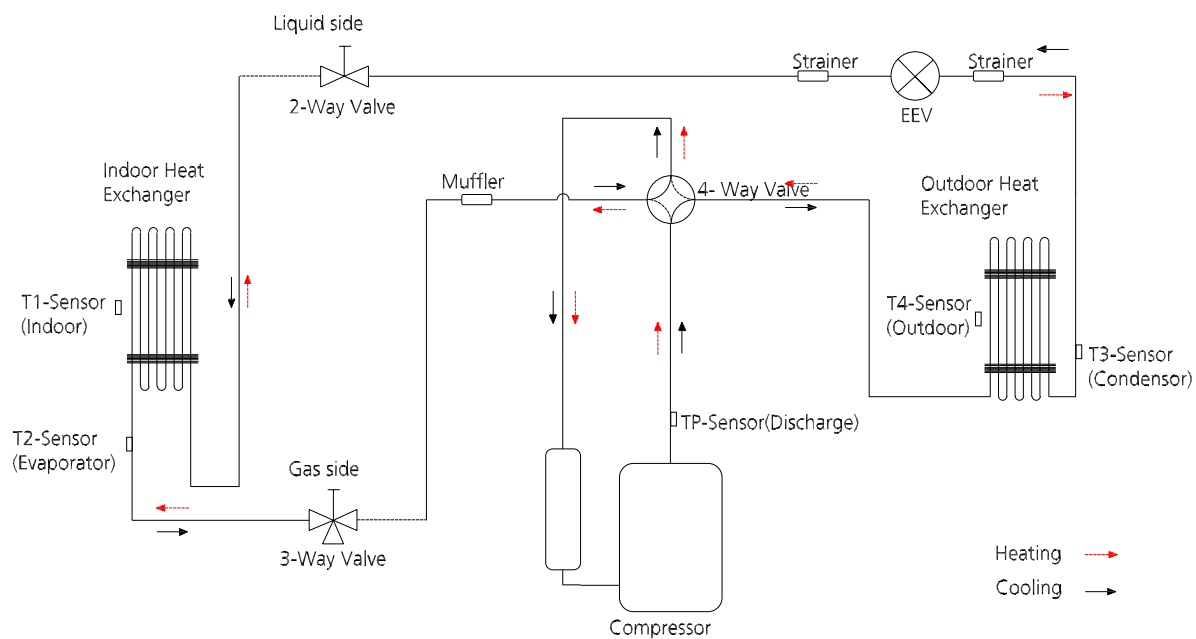

Model	Pipe Size (Diameter:ø) mm(inch)		Piping length (m/ft)		Elevation (m/ft)		Additional Refrigerant
	Gas	Liquid	Rated	Max.	Rated	Max.	
MOX230-12HFN1-MV5W	12.7(1/2)	6.35(1/4)	7.5/24.6	25/82	0	10/32.8	15g/m (0.16oz/ft)
MOX330-12HFN1-MW5W							

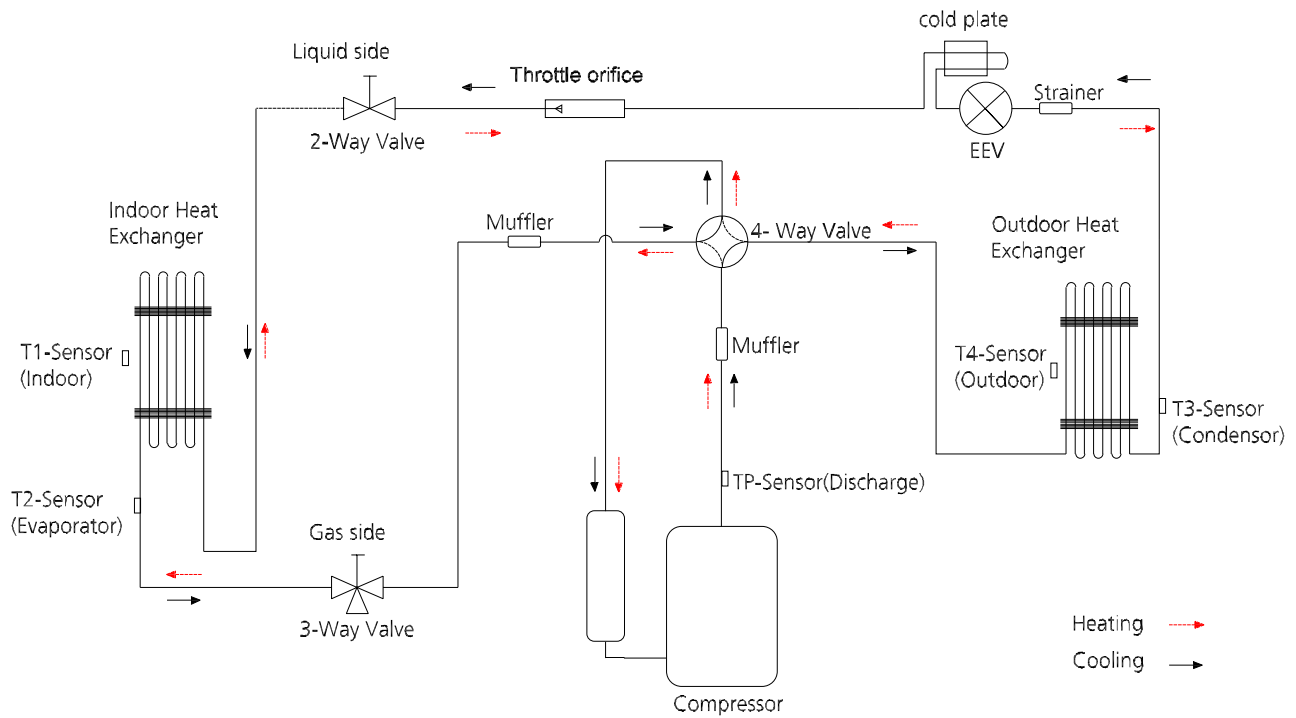

Model	Pipe Size (Diameter:ø) mm(inch)		Piping length (m/ft)		Elevation (m/ft)		Additional Refrigerant
	Gas	Liquid	Rated	Max.	Rated	Max.	
MOX430-18HFN1-MU0W	12.7(1/2)	6.35(1/4)	7.5/24.6	30/98.4	0	20/65.6	15g/m (0.16oz/ft)
MOX430-17HFN1-MT0W							



---

#### 4. Electrical Wiring Diagrams

ODU Model	ODU Wiring Diagram
MOX230-12HFN1-MV5W	16022000035853
MOX330-12HFN1-MW5W	
MOX430-18HFN1-MU0W	16022000035849
MOX430-17HFN1-MT0W	

ODU Model	ODU Main Printed Circuit Board
MOX230-12HFN1-MV5W	17122000048121
MOX330-12HFN1-MW5W	
MOX430-18HFN1-MU0W	17122000048066
MOX430-17HFN1-MT0W	17122000041117

# WIRING DIAGRAM

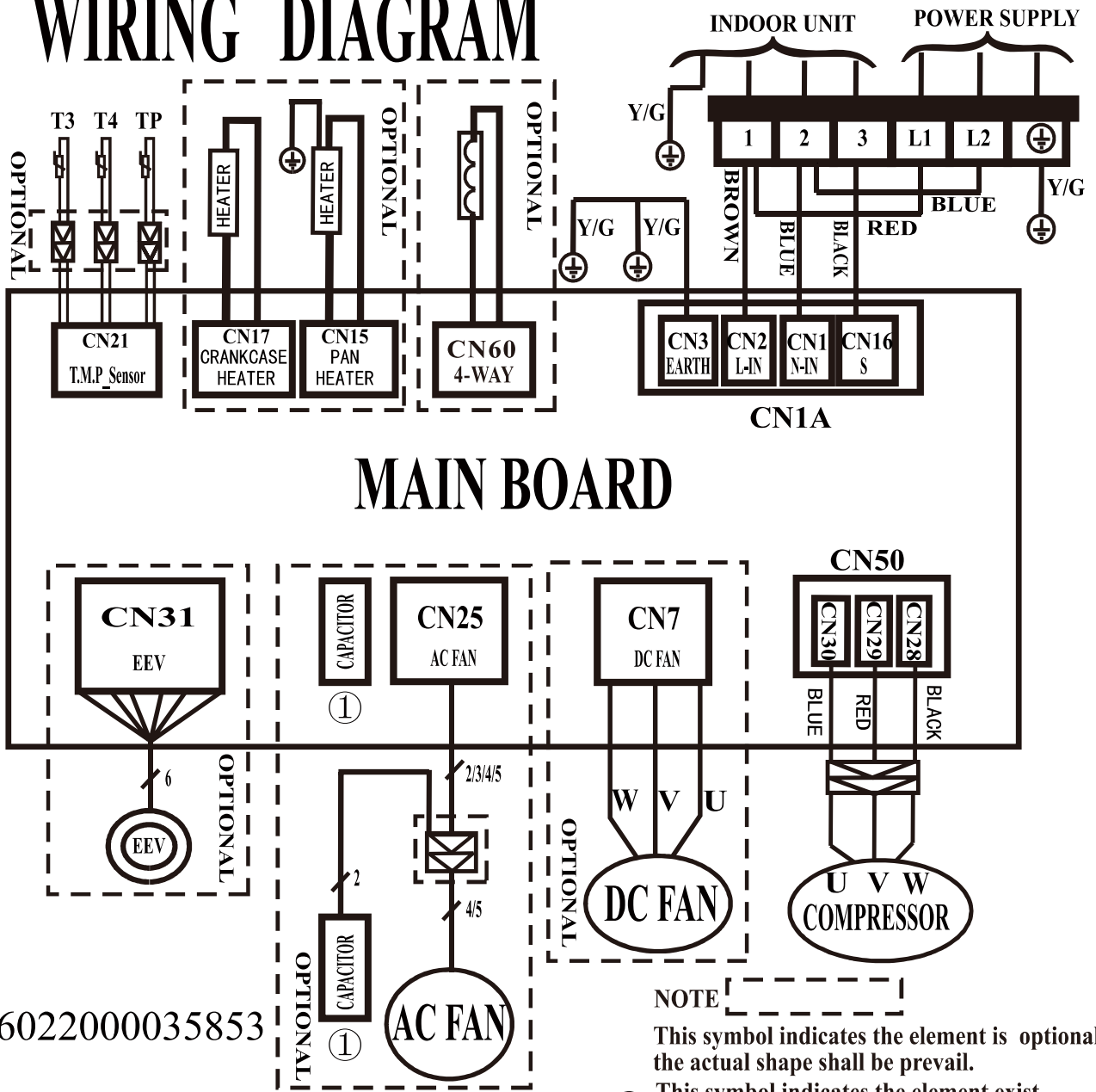

16022000035853

**NOTE**

- This symbol indicates the element is optional, the actual shape shall prevail.
- ① This symbol indicates the element exist various locations

# WIRING DIAGRAM

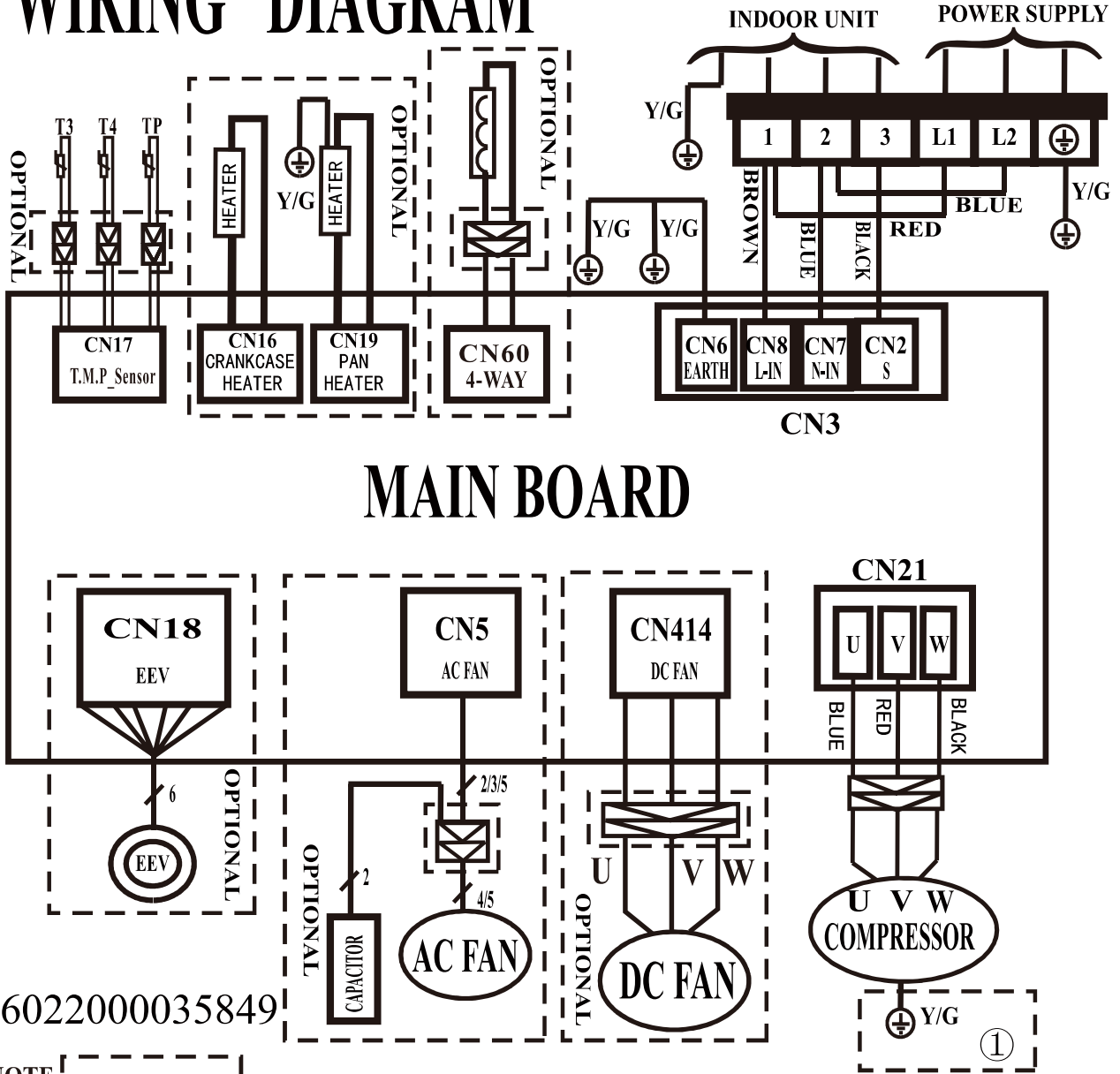

16022000035849

**NOTE**

This symbol indicates the element is optional, the actual shape shall be prevail.

①

The D box contains the ground wire of the compressor, and the other boxes do not.



No.	Name	CN#	Meaning
1	CN1A	CN3	Earth: connect to Ground
		CN1	N_in: connect to N-line (208-230V AC input)
		CN2	L_in: connect to L-line (208-230V AC input)
		CN16	S: connect to indoor unit communication
2	HEAT1	CN17	connect to compressor heater, 208-230V AC when is ON
3	4-WAY	CN60	connect to 4 way valve, 208-230V AC when is ON.
4	HEAT2	CN15	connect to chassis heater, 208-230V AC when is ON
5	AC-FAN	CN25	connect to AC fan
6	PMV	CN31	connect to Electric Expansion Valve
7	TESTPORT	CN6	used for testing
8	TP T4 T3	CN21/CN22	connect to pipe temp. sensor T3, ambient temp. sensor T4, exhaust temp. sensor TP
9	DC-FAN	CN7	connect to DC fan
10	FAN_IPM	IPM 501	IPM for DC fan
11	W	CN28	connect to compressor
	V	CN29	0V AC (standby)
	U	CN30	10-200V AC (running)
12	COMP_IPM	IPM 301	IPM for compressor

**Note: This section is for reference only. Please take practicality as standard.**

Outdoor unit printed circuit board diagram: 17122000048064& 17122000048066

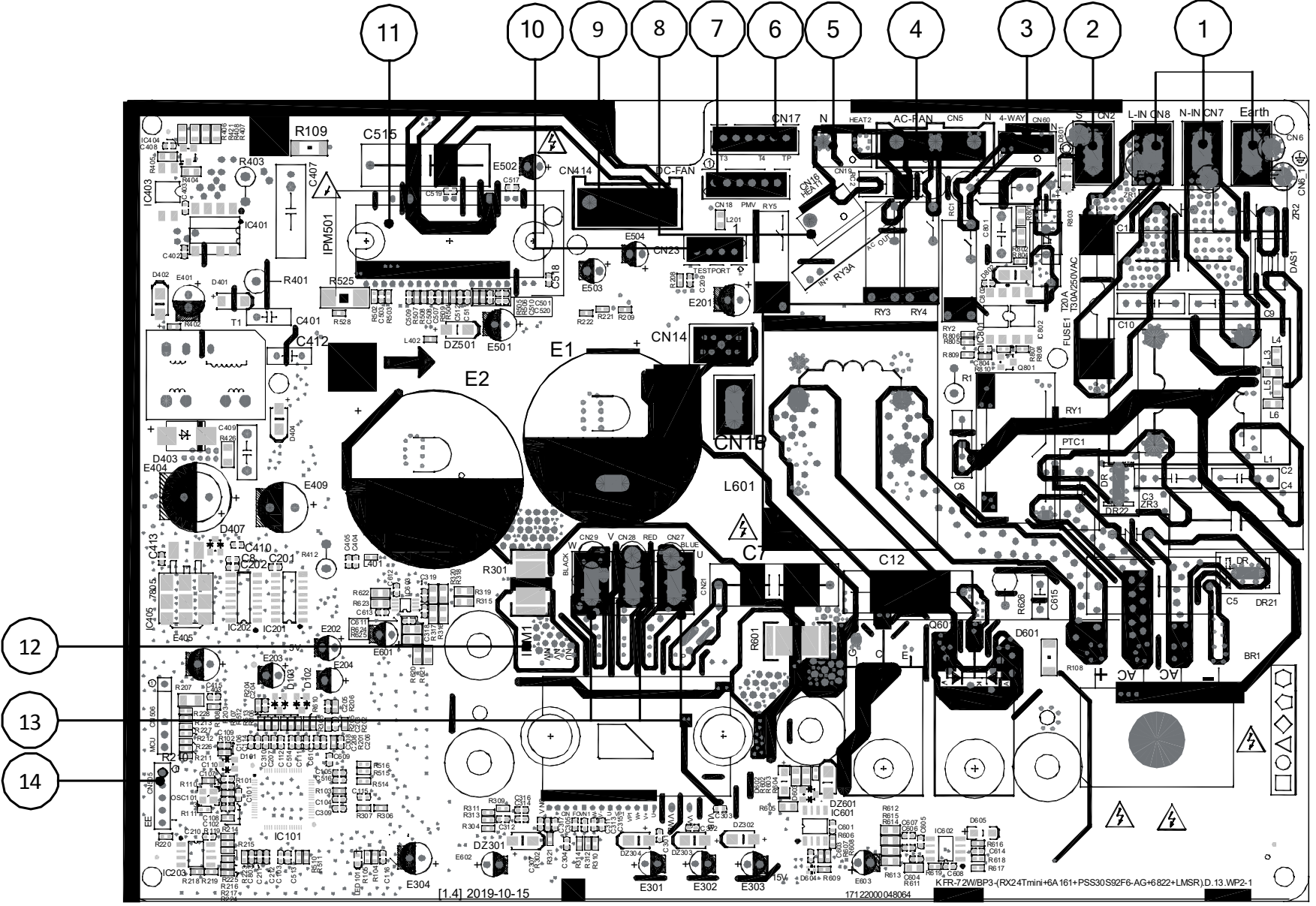

- 12
- 13
- 14

No.	Name	CN#	Meaning
1	Power Supply	CN6	Earth: connect to Ground
		CN7	N_in: connect to N-line (208-230V AC input)
		CN8	L_in: connect to L-line (208-230V AC input)
2	S	CN2	S: connect to indoor unit communication
3	4-WAY	CN60	connect to 4 way valve, 208-230V AC when is ON.
4	AC-FAN	CN5	connect to AC fan
5	HEAT2	CN19	connect to chassis heater, 208-230V AC when is ON
6	TP T4 T3	CN17	connect to pipe temp. sensor T3, ambient temp. sensor T4, exhaust temp. sensor TP
7	PMV	CN18	connect to Electric Expansion Valve
8	HEAT1	CN16	connect to compressor heater, 208-230V AC when is ON
9	DC-FAN	CN414	connect to DC fan
10	TESTPORT	CN23	used for testing
11	FAN_IPM	IPM501	IPM for DC fan
12	COMP_IPM	IPM1	IPM for compressor
13	U	CN27	connect to compressor
	V	CN28	0V AC (standby)
	W	CN29	200-300V AC (running)
14	EE_PORT	CN505	EEPROM programer port

**Note: This section is for reference only. Please take practicality as standard.**

Outdoor unit printed circuit board diagram: 17122000041117, 17122000034170

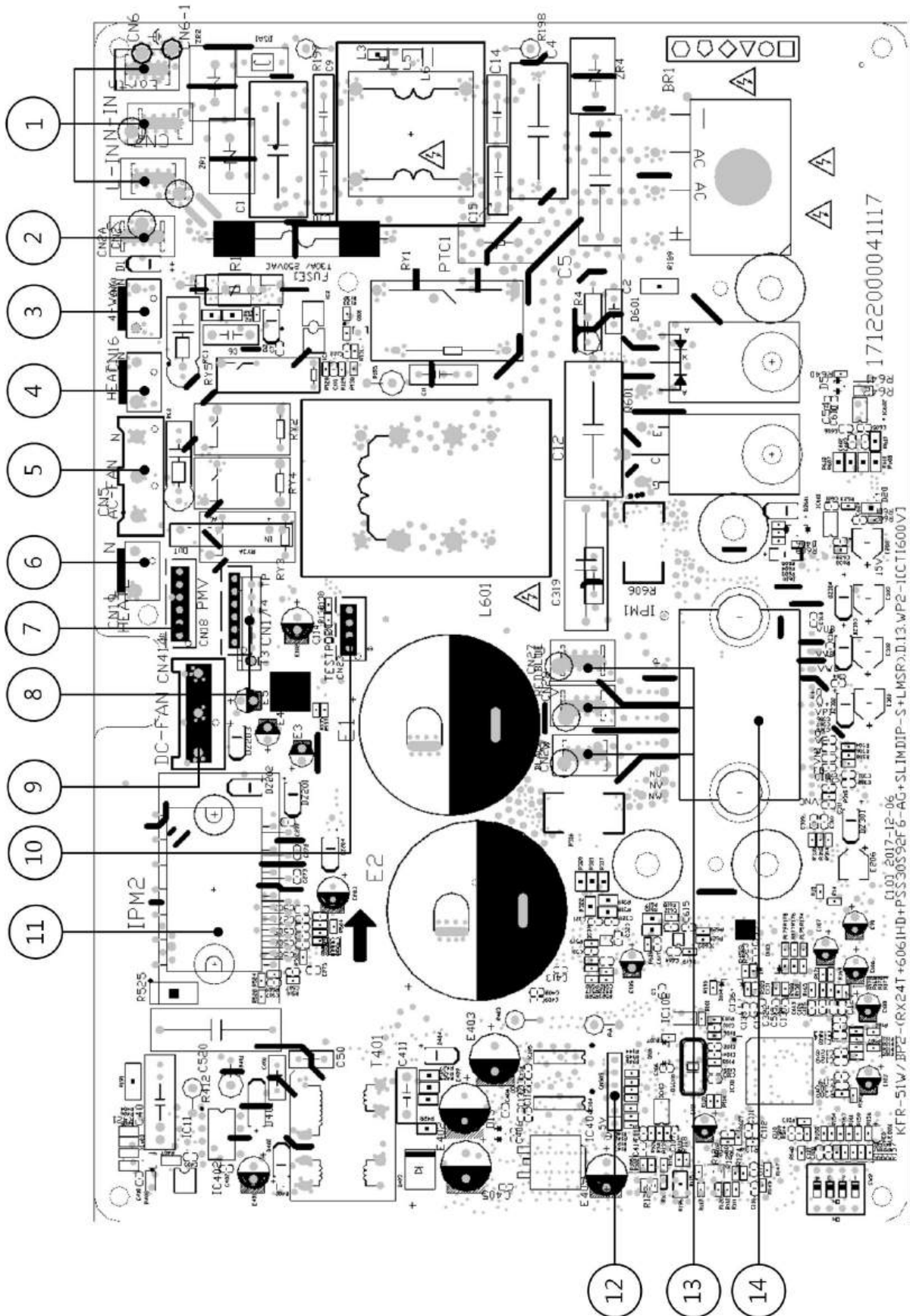



No.	Name	CN#	Meaning
1	Power Supply	CN6	Earth: connect to Ground
		CN7	N_in: connect to N-line (208-230V AC input)
		CN8	L_in: connect to L-line (208-230V AC input)
2	S	CN2	S: connect to indoor unit communication
3	4-WAY	CN60	connect to 4 way valve, 208-230V AC when is ON.
4	HEAT1	CN16	connect to compressor heater, 208-230V AC when is ON
5	AC-FAN	CN5	connect to AC fan
6	HEAT2	CN19	connect to chassis heater, 208-230V AC when is ON
7	PMV	CN18	connect to Electric Expansion Valve
8	TP T4 T3	CN17	connect to pipe temp. sensor T3, ambient temp. sensor T4, exhaust temp. sensor TP
9	DC-FAN	CN41	connect to DC fan
10	TESTPORT	CN23	used for testing
11	FAN_IPM	IPM2	IPM for DC fan
12	EE_PORT	CN505	EEPROM programmer port
13	U	CN27	connect to compressor
	V	CN28	0V AC (standby)
	W	CN29	200-300V AC (running)
14	COMP_IPM	IPM1	IPM for compressor

**Note: This section is for reference only. Please take practicality as standard.**

---

# Installation

## Contents

1. Installation Overview
2. Location Selection
3. Indoor Unit Installation
4. Outdoor Unit Installation
5. Drainage Pipe Installation
6. Refrigerant Pipe Installation
7. Vacuum Drying and Leakage Checking
8. Additional Refrigerant Charge
9. Engineering of Insulation
10. Engineering of Electrical Wiring
11. Test Operation

# 1. Installation Overview

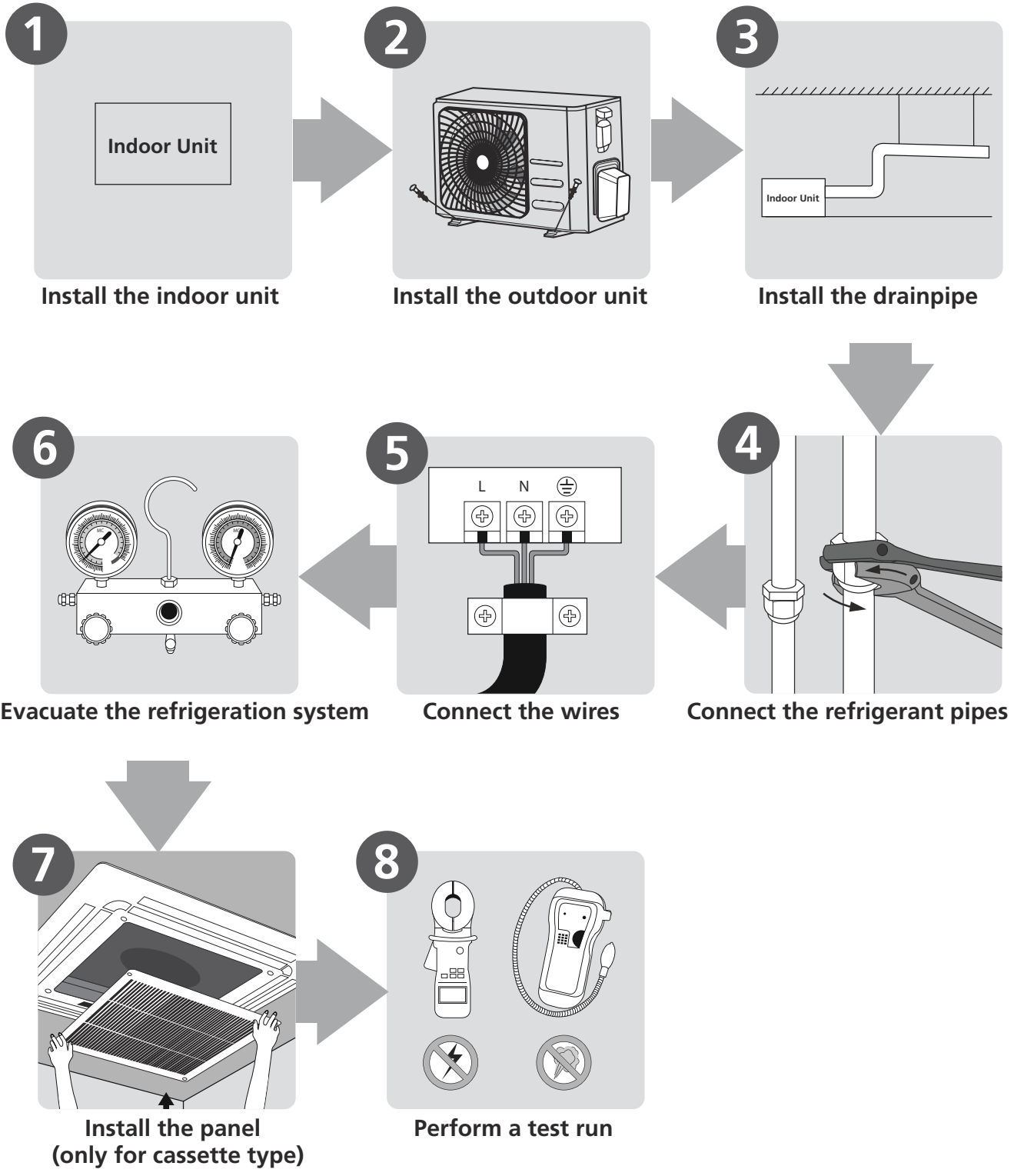

## 2. Location selection

2.1 Unit location selection can refer to installation manual.

2.2 DO NOT install the unit in the following locations:

- Where oil drilling or fracking is taking place.
- Coastal areas with high salt content in the air.
- Areas with caustic gases in the air, such as near hot springs.
- Areas with power fluctuations, such as factories.
- Enclosed spaces, such as cabinets.
- Areas with strong electromagnetic waves.
- Areas that store flammable materials or gas.
- Rooms with high humidity, such as bathrooms or laundry rooms.
- If possible, DO NOT install the unit where it is exposed to direct sunlight.

### 2.3 Rows of series installation

The relations between H, A and L are as follows.

	L	A
L ≤ H	$L \leq 1/2H$	25 cm / 9.8" or more
	$1/2H < L \leq H$	30 cm / 11.8" or more
L > H	Can not be installed	

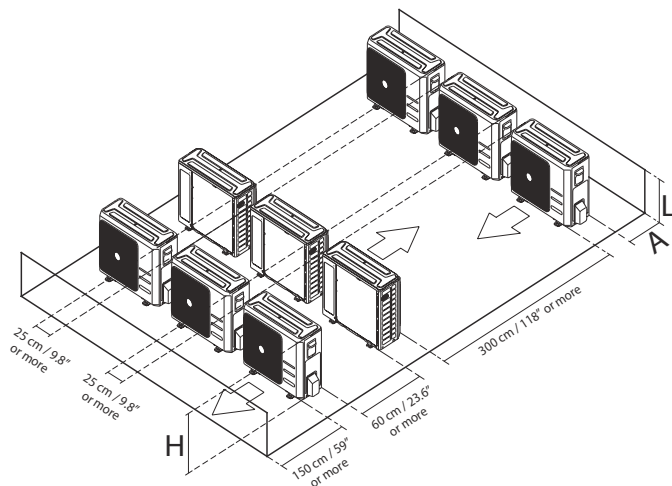

DO NOT install the rows of series like following figure.

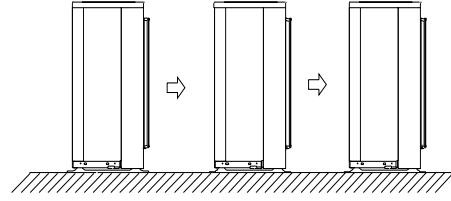

### 2.4 If the unit is exposed to heavy wind:

- Install unit so that air outlet fan is at a 90° angle to the direction of the wind. If needed, build a barrier in front of the unit to protect it from extremely heavy winds.

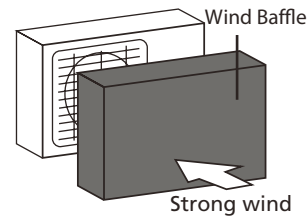
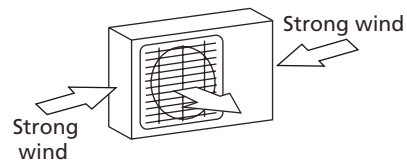

### 2.5 If the unit is frequently exposed to heavy rain or snow:

Build a shelter above the unit to protect it from the rain or snow. Be careful not to obstruct air flow around the unit.

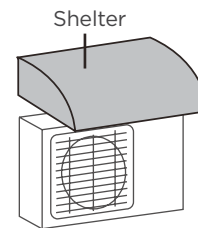

### 2.6 If the unit is frequently exposed to salty air (seaside):

Use outdoor unit that is specially designed to resist corrosion.

### 3. Indoor Unit Installation(New Console)

#### 3.1 Service space for indoor unit

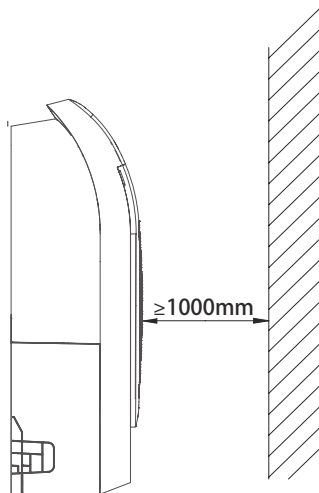
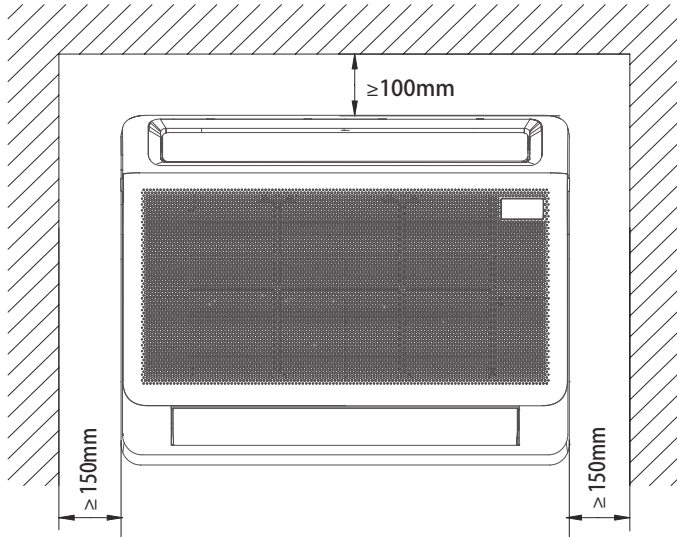

#### 3.2 Installing the main body

1. After loosening the screws, remove the mounting plate from the unit.

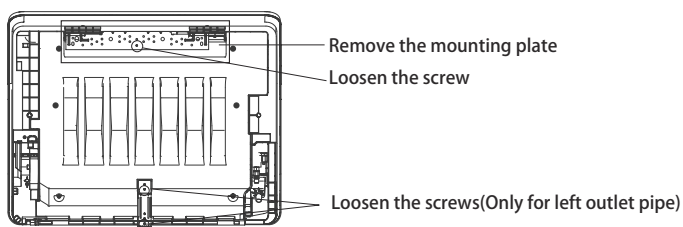

NOTE: If the pipe comes out on the left, it is necessary to loosen the screws on the bottom mounting plate. If the pipe comes out in other directions, it is not necessary.

2. Fix the mounting plate with a tapping screw onto the wall.

NOTE: It is recommended to fix it on the wall according to the hanging hole indicated by the arrow on the mounting plate. Mounting plate must be installed horizontally.

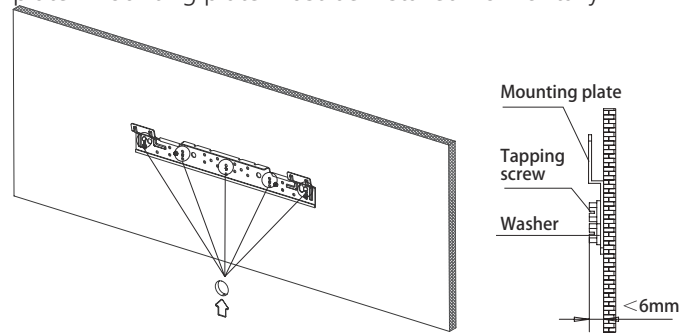

3. Hang the indoor unit on the mounting plate. (The bottom of body can touch the floor or remain suspended, but the body must be installed vertically.)

NOTE: After installation, the unit shall be kept horizontal without tilting.

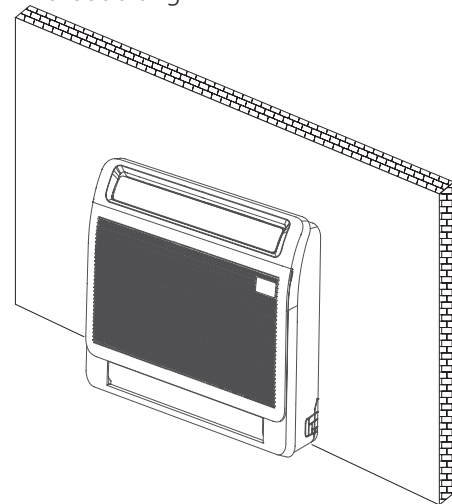

#### 4. Bottom mounting plate installation

- Installation without skirting

The bottom mounting plate is fixed directly to the wall.

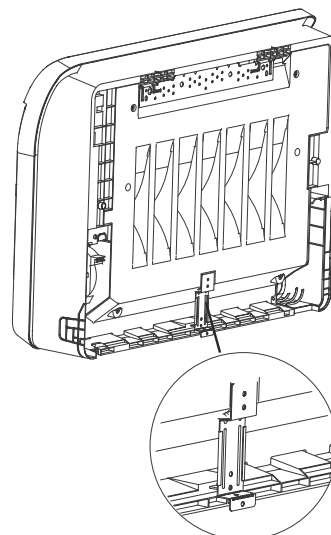

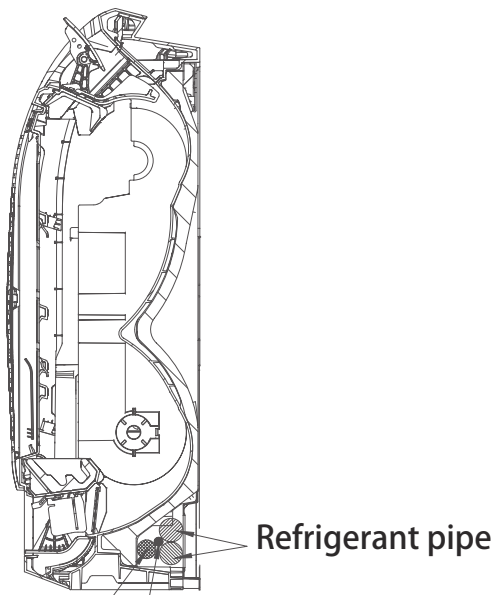

**Drain-pipe Power cord**

NOTE: In order to drain smoothly, the position of the drain pipe must refer to the above figure when discharging the right pipe.

- Installation with skirting line

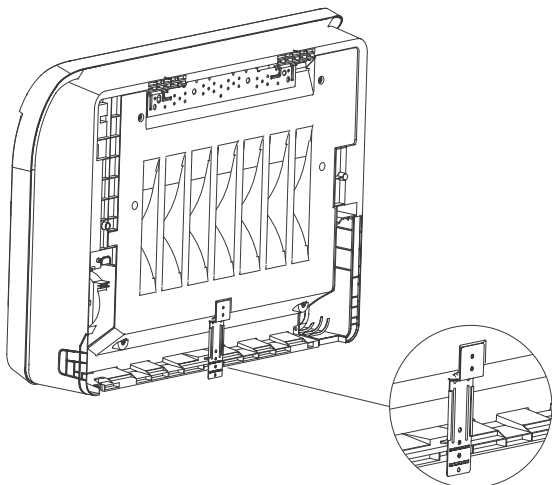
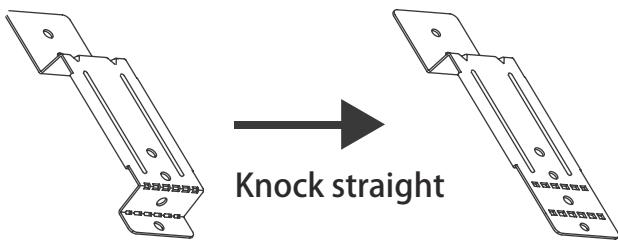

open the piping cover plate.

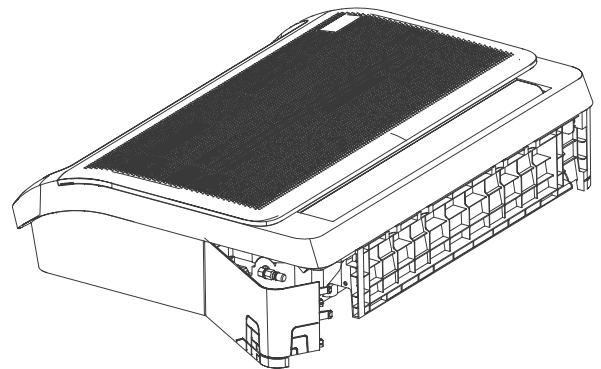
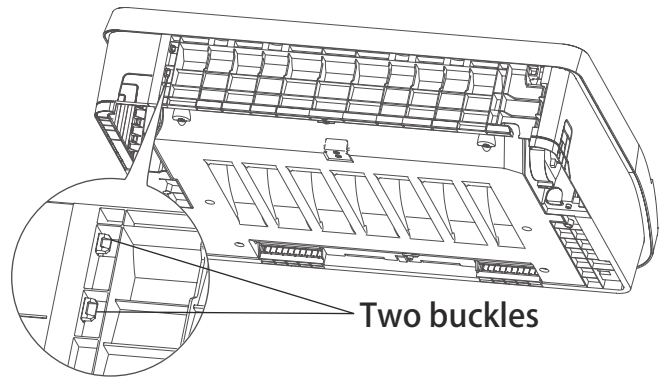

2. Remove the cover plate.

Remove the pipe cover plate and install the internal and external connecting pipes.

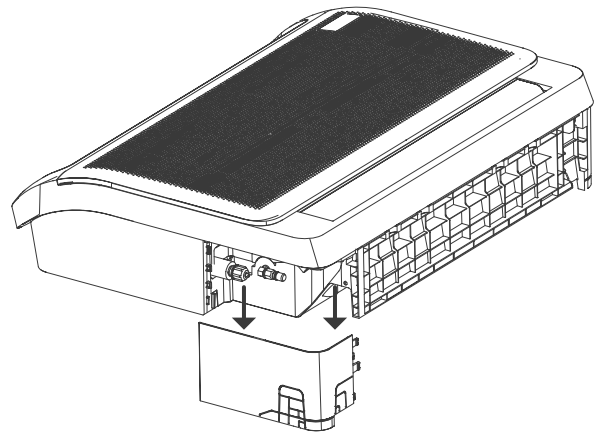

NOTE: Install small-size piping first, and then large-size piping.

NOTE: All the figures in this manual are for demonstration purposes only. The air conditioner you have purchased may be slightly different in design, though similar in shape.

### 3.3 Taking the indoor unit apart to connect the pipe

#### 1. Open the bottom piping cover plate

Press and hold the bottom two buckles, and then rotate to

## 4. Outdoor unit installation

### 4.1 Service space for outdoor unit

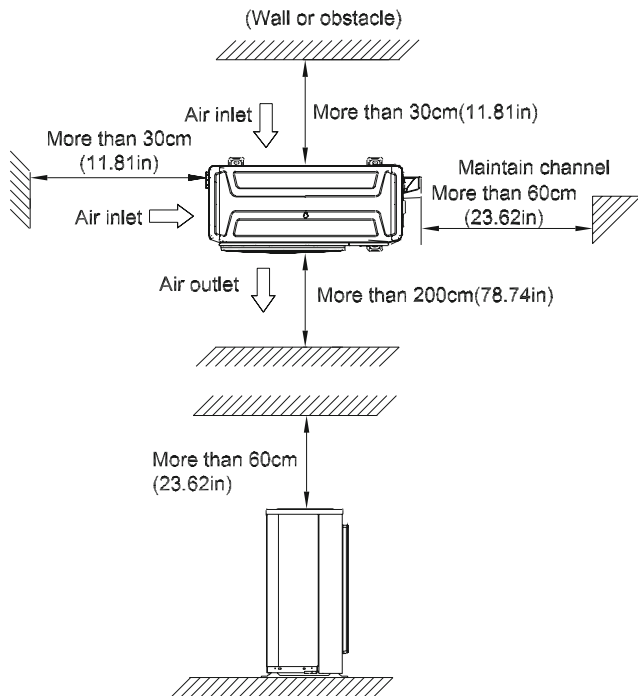

### 4.2 Install drain joint(Heat pump unit only)

Before bolting the outdoor unit in place, you must install the drain joint at the bottom of the unit.

Note that there are two different types of drain joints depending on the type of outdoor unit.

If the drain joint comes with a rubber seal(see Fig. A ), do the following:

1. Fit the rubber seal on the end of the drain joint that will connect to the outdoor unit.
2. Insert the drain joint into the hole in the base pan of the unit.
3. Rotate the drain joint 90° until it clicks in place facing the front of the unit. **For some panel plates, you need to use tool.**
4. Connect a drain hose extension (not included) to the drain joint to redirect water from the unit during heating mode.

If the drain joint doesn't come with a rubber seal (see Fig. B ), do the following:

1. Insert the drain joint into the hole in the base pan of the unit. The drain joint will click in place.

2. Connect a drain hose extension (not included) to the drain joint to redirect water from the unit during heating mode.

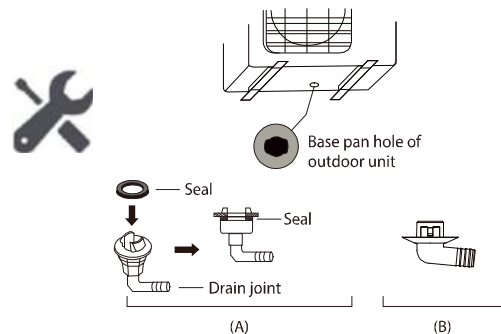

### 4.3 Bolt pitch

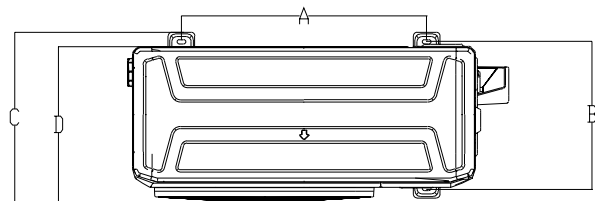

Panel Plate	Unit	D	A	B	C
X2	mm	303	452	286	314
	inch	11.93	17.80	11.26	12.36
X3	mm	330	511	317	346
	inch	12.99	20.12	12.48	13.62
X4	mm	342	663	354	394
	inch	13.46	26.1	13.94	15.5
X6	mm	375	615	397	440
	inch	14.76	24.2	15.6	17.3
D30	mm	410	673	403	455
	inch	16.14	26.50	15.87	17.9
E30	mm	415	634	404	457
	inch	16.34	24.96	15.9	17.99
590	mm	350	590	378	400
	inch	13.78	23.23	14.88	15.75

---

## 4.4 Install Outdoor Unit

### Fix the outdoor unit with anchor bolts(M10)

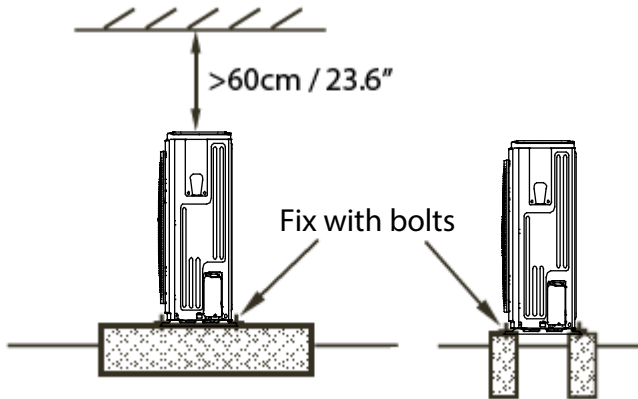

### Caution

Since the gravity center of the unit is not at its physical center, so please be careful when lifting it with a sling.

Never hold the inlet of the outdoor unit to prevent it from deforming.

Do not touch the fan with hands or other objects.

Do not lean it more than 45, and do not lay it sidelong.

Make concrete foundation according to the specifications of the outdoor units.

Fasten the feet of this unit with bolts firmly to prevent it from collapsing in case of earthquake or strong wind.



## 5. Drainage Pipe Installation

Install the drainage pipe as shown below and take measures against condensation. Improperly installation could lead to leakage and eventually wet furniture and belongings.

### 5.1 Installation principle

- Ensure at least 1/100 slope of the drainage pipe
- Adopt suitable pipe diameter
- Adopt nearby condensate water discharge

### 5.2 Key points of drainage water pipe installation

1. Considering the pipeline route and elevation.

- Before installing condensate water pipeline, determine its route and elevation to avoid intersection with other pipelines and ensure slope is straight.

2. Drainage pipe selection

- The drainage pipe diameter shall not small than the drain hose of indoor unit
- According to the water flowrate and drainage pipe slope to choose the suitable pipe, the water flowrate is decided by the capacity of indoor unit.

#### Relationship between water flowrate and capacity of indoor unit

Capacity (kBtu/h)	Water flowrate (l/h)
12	2.4
18	4
24	6
30	7
36	8
42	10
48	12
60	14

According to the above table to calculate the total water flowrate for the confluence pipe selection.

**For horizontal drainage pipe** (The following table is for reference)

PVC pipe	Reference value of inner diameter of pipe (mm)	Allowable maximum water flowrate (l/h)		Remark
		Slope 1/50	Slope 1/100	
PVC25	20	39	27	For branch pipe
PVC32	25	70	50	
PVC40	31	125	88	Could be used for confluence pipe
PVC50	40	247	175	
PVC63	51	473	334	

Attention: Adopt PVC40 or bigger pipe to be the main pipe.

**For Vertical drainage pipe** (The following table is for reference)

PVC pipe	Reference value of inner diameter of pipe (mm)	Allowable maximum water flowrate (l/h)	Remark
PVC25	20	220	For branch pipe
PVC32	25	410	
PVC40	31	730	Could be used for confluence pipe
PVC50	40	1440	
PVC63	51	2760	
PVC75	67	5710	
PVC90	77	8280	

Attention: Adopt PVC40 or bigger pipe to be the main pipe.

3. Individual design of drainage pipe system

- The drainage pipe of air conditioner shall be installed separately with other sewage pipe, rainwater pipe and drainage pipe in building.
- The drainage pipe of the indoor unit with water pump should be apart from the one without water pump.

4. Supporter gap of drainage pipe

- In general, the supporter gap of the drainage pipe horizontal pipe and vertical pipe is respectively 1m~1.5m/3.28ft~4.92ft and 1.5m~2.0m/4.92ft/6.56ft.
- Each vertical pipe shall be equipped with not less than two hangers.
- Overlarge hanger gap for horizontal pipe shall create bending, thus leading to air block.

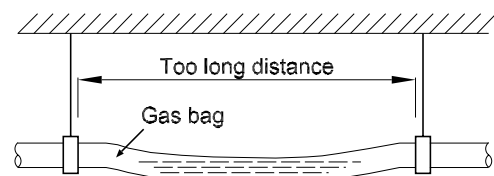

5. The horizontal pipe layout should avoid converse flow or bad flow

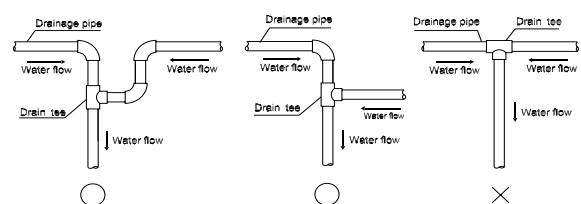

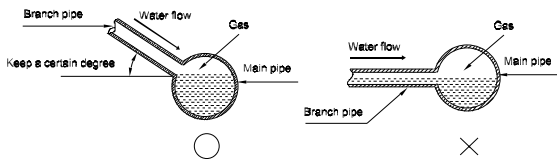

- The correct installation will not cause converse water flow and the slope of the branch pipes can be adjusted freely
- The false installation will cause converse water flow and the slope of the branch pipe can not be adjusted.

#### 6. Water storage pipe setting

- If the indoor unit has high extra static pressure and without water pump to elevate the condensate water, such as high extra static pressure duct unit, the water storage pipe should be set to avoid converse flow or blow water phenomena.

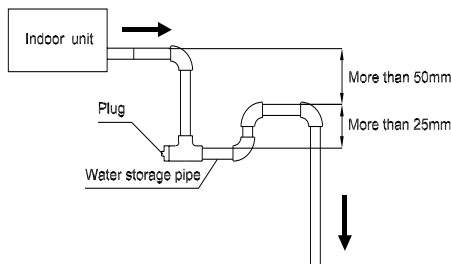

#### 7. Lifting pipe setting of indoor unit with water pump

- The length of lifting pipe should not exceed 750mm/29.5in or 1m/39.4in(for new 4-way cassette);

The drainage pipe should be set down inclined after the lifting pipe immediately to avoid wrong operation of water level switch.

- Refer the following picture for installation reference.

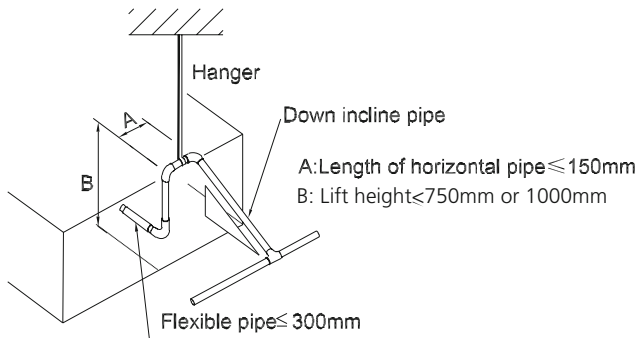

#### 8. Blowhole setting

- For the concentrated drainage pipe system, there

should design a blowhole at the highest point of main pipe to ensure the condensate water discharge smoothly.

- The air outlet shall face down to prevent dirt entering pipe.
- Each indoor unit of the system should be installed it.
- The installation should be considering the convenience for future cleaning.

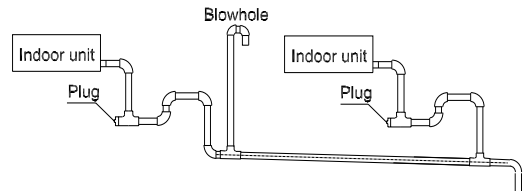

- 9. The end of drainage pipe shall not contact with ground directly.

### 5.3 Insulation work of drainage pipe

Refer the introduction to the insulation engineering parts.

## 6. Refrigerant Pipe Installation

### 6.1 Recommended copper pipe thickness

Pipe Diameter	Thickness(mm/inch)
1/4" (6.35)	0.6/0.024
3/8" (9.52)	0.7/0.028
1/2" (12.7)	0.75/0.03
5/8" (15.9)	0.75/0.03
3/4" (19)	0.8/0.031
7/8" (22)	1/0.039

### 6.2 Maximum length and drop height

Ensure that the length of the refrigerant pipe, the number of bends, and the drop height between the indoor and outdoor units meets the requirements shown in the following table.

Capacity(kBtu/h)	Max. Length (m/ft)	Max. Elevation (m/ft)
<15	25/82	10/32.8
15-23	30/98.4	20/65.6
24~35	50/164	25/82
36~60	65/213.3	30/98.4

Caution:

1. The capacity test is based on the standard length and the maximum permissible length is based on the system reliability.

2. Oil traps

-If oil flows back into the outdoor unit's compressor, this might cause liquid compression or deterioration of oil return. Oil traps in the rising gas piping can prevent this.

-An oil trap should be installed every 6m(20ft) of vertical suction line riser (<36000Btu/h unit).

-An oil trap should be installed every 10m(32.8ft) of vertical suction line riser (≥36000Btu/h unit).

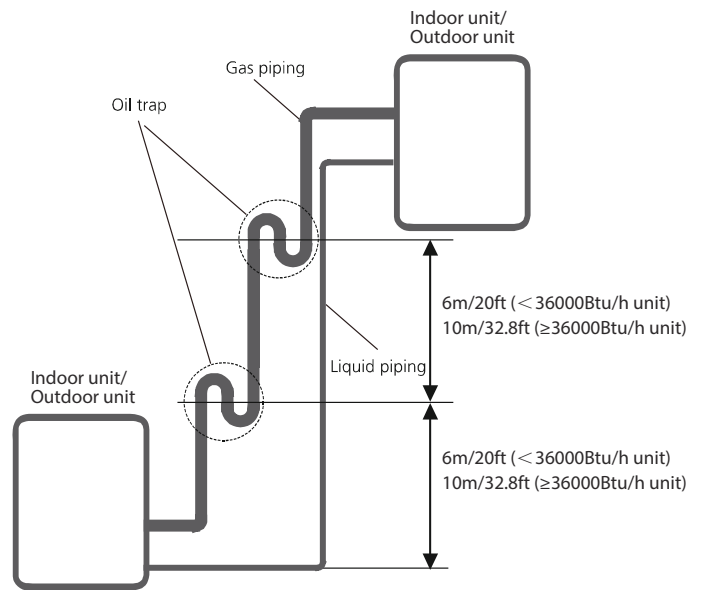

### 6.3 The procedure of connecting pipes

1. Choose the pipe size according to the specification table.
2. Confirm the cross way of the pipes.
3. Measure the necessary pipe length.
4. Cut the selected pipe with pipe cutter

- Make the section flat and smooth.

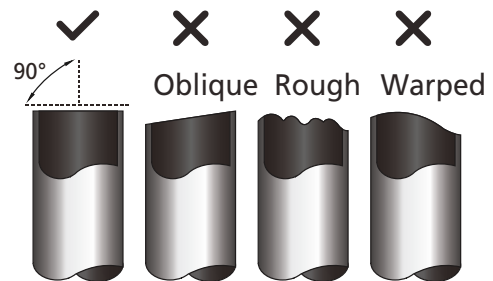

5. Insulate the copper pipe

- Before test operation, the joint parts should not be heat insulated.

6. Flare the pipe

- Insert a flare nut into the pipe before flaring the pipe
- According to the following table to flare the pipe.

Pipe diameter (inch(mm))	Flare dimension A (mm/inch)		Flare shape
	Min	Max	
1/4" (6.35)	8.4/0.33	8.7/0.34	
3/8" (9.52)	13.2/0.52	13.5/0.53	
1/2" (12.7)	16.2/0.64	16.5/0.65	
5/8" (15.9)	19.2/0.76	19.7/0.78	
3/4" (19)	23.2/0.91	23.7/0.93	
7/8" (22)	26.4/1.04	26.9/1.06	

- After flared the pipe, the opening part must be seal by end cover or adhesive tape to avoid duct or exogenous impurity come into the pipe.

7. Drill holes if the pipes need to pass the wall.

8. According to the field condition to bend the pipes so that it can pass the wall smoothly.

9. Bind and wrap the wire together with the insulated pipe if necessary.

10. Set the wall conduit

11. Set the supporter for the pipe.

12. Locate the pipe and fix it by supporter

- For horizontal refrigerant pipe, the distance between supporters should not be exceed 1m.
- For vertical refrigerant pipe, the distance between supporters should not be exceed 1.5m.

13. Connect the pipe to indoor unit and outdoor unit by using two spanners.

- Be sure to use two spanners and proper torque to fasten the nut, too large torque will damage the bellmouthing, and too small torque may cause leakage. Refer the following table for different pipe connection.

Pipe Diameter	Torque	Sketch map
	N.m(lb.ft)	
1/4" (6.35)	18~20 (13.3~14.8)	
3/8" (9.52)	32~39 (23.6~28.8)	
1/2" (12.7)	49~59 (36.1~43.5)	
5/8" (15.9)	57~71 (42~52.4)	
3/4" (19)	67~101 (49.4~74.5)	
7/8" (22)	85~110	
	(62.7~81.1)	

## 7. Vacuum Drying and Leakage Checking

### 7.1 Purpose of vacuum drying

- Eliminating moisture in system to prevent the phenomena of ice-blockage and copper oxidation. Ice-blockage shall cause abnormal operation of system, while copper oxide shall damage compressor.
- Eliminating the non-condensable gas (air) in system to prevent the components oxidizing, pressure fluctuation and bad heat exchange during the operation of system.

### 7.2 Selection of vacuum pump

- The ultimate vacuum degree of vacuum pump shall be -756mmHg or above.
- Precision of vacuum pump shall reach 0.02mmHg or above.

### 7.3 Operation procedure for vacuum drying

Due to different construction environment, two kinds of vacuum drying ways could be chosen, namely ordinary vacuum drying and special vacuum drying.

#### 7.3.1 Ordinary vacuum drying

1. When conduct first vacuum drying, connect pressure gauge to the infusing mouth of gas pipe and liquid pipe, and keep vacuum pump running for 1 hour (vacuum degree of vacuum pump shall be reached -755mmHg).
2. If the vacuum degree of vacuum pump could not reach -755mmHg after 1 hour of drying, it indicates that there is moisture or leakage in pipeline system and need to go on with drying for half an hour.
3. If the vacuum degree of vacuum pump still could not reach -755mmHg after 1.5 hours of drying, check whether there is leakage source.
4. Leakage test: After the vacuum degree reaches -755mmHg, stop vacuum drying and keep the pressure for 1 hour. If the indicator of vacuum gauge does not go up, it is qualified. If going up, it indicates that there is moisture or leak source.

#### 7.3.2 Special vacuum drying

The special vacuum drying method shall be adopted when:

1. Finding moisture during flushing refrigerant pipe.
2. Conducting construction on rainy day, because rain water might penetrated into pipeline.
3. Construction period is long, and rain water might penetrated into pipeline.

4. Rain water might penetrate into pipeline during construction.

Procedures of special vacuum drying are as follows:

1. Vacuum drying for 1 hour.
2. Vacuum damage, filling nitrogen to reach 0.5Kgf/cm<sup>2</sup> .

Because nitrogen is dry gas, vacuum damage could achieve the effect of vacuum drying, but this method could not achieve drying thoroughly when there is too much moisture. Therefore, special attention shall be drawn to prevent the entering of water and the formation of condensate water.

3. Vacuum drying again for half an hour.

If the pressure reached -755mmHg, start to pressure leakage test. If it cannot reached the value, repeat vacuum damage and vacuum drying again for 1 hour.

4. Leakage test: After the vacuum degree reaches -755mmHg, stop vacuum drying and keep the pressure for 1 hour. If the indicator of vacuum gauge does not go up, it is qualified. If going up, it indicates that there is moisture or leak source.

## 8. Additional Refrigerant Charge

- After the vacuum drying process is carried out, the additional refrigerant charge process need to be performed.
- The outdoor unit is factory charged with refrigerant. The additional refrigerant charge volume is decided by the diameter and length of the liquid pipe between indoor and outdoor unit. Refer the following formula to calculate the charge volume.

	Diameter of liquid pipe (mm(inch))	Formula
R410A(Throttling part in the indoor unit)	6.35(1/4)	$V=30(0.32)g/m(oz/ft) \times (L - \text{standard pipe length})$
	9.52(3/8)	$V=65(0.69)g/m(oz/ft) \times (L - \text{standard pipe length})$
	12.7(1/2)	$V=115(1.23)g/m(oz/ft) \times (L - \text{standard pipe length})$
R410A(Throttling part in the outdoor unit)	6.35(1/4)	$V=15(0.16)g/m(oz/ft) \times (L - \text{standard pipe length})$
	9.52(3/8)	$V=30(0.32)g/m(oz/ft) \times (L - \text{standard pipe length})$
	12.7(1/2)	$V=65(0.69)g/m(oz/ft) \times (L - \text{standard pipe length})$
R32	6.35(1/4)	$V=12(0.13)g/m(oz/ft) \times (L - \text{standard pipe length})$
	9.52(3/8)	$V=24(0.26)g/m(oz/ft) \times (L - \text{standard pipe length})$
	12.7(1/2)	$V=40(0.42)g/m(oz/ft) \times (L - \text{standard pipe length})$

**V:** Additional refrigerant charge volume.

**L :** The length of the liquid pipe.

Note:

- Refrigerant may only be charged after performed the vacuum drying process.
- Always use gloves and glasses to protect your hands and eyes during the charge work.
- Use electronic scale or fluid infusion apparatus to weight refrigerant to be recharged. Be sure to avoid extra refrigerant charged, it may cause liquid hammer of the compressor or protections.
- Use supplementing flexible pipe to connect refrigerant cylinder, pressure gauge and outdoor unit. And The refrigerant should be charged in liquid state. Before recharging, The air in the flexible pipe and manifold gauge should be exhausted.
- After finished refrigerant recharge process, check whether there is refrigerant leakage at the connection joint part.(Using gas leakage detector or soap water to detect).

## 9 . Engineering of Insulation

### 9.1 Insulation of refrigerant pipe

#### 1. Operational procedure of refrigerant pipe insulation

Cut the suitable pipe → insulation (except joint section) → flare the pipe → piping layout and connection → vacuum drying → insulate the joint parts

#### 2. Purpose of refrigerant pipe insulation

- During operation, temperature of gas pipe and liquid pipe shall be over-heating or over-cooling extremely. Therefore, it is necessary to carry out insulation; otherwise it shall debase the performance of unit and burn compressor.
- Gas pipe temperature is very low during cooling. If insulation is not enough, it shall form dew and cause leakage.
- Temperature of gas pipe is very high (generally 50-100°C/122-212°F) during heating. Insulation work must be carried out to prevent hurt by carelessness touching.

#### 3. Insulation material selection for refrigerant pipe

- The burning performance should over 120°C/248°F
- According to the local law to choose insulation materials
- Recommended insulation casing thickness

Humidity < 80%RH	Humidity ≥ 80%RH
10mm/0.39in	15mm/0.59in

#### 4. Installation highlights of insulation construction

- Gas pipe and liquid pipe shall be insulated separately, if the gas pipe and liquid pipe were insulated together; it will decrease the performance of air conditioner.

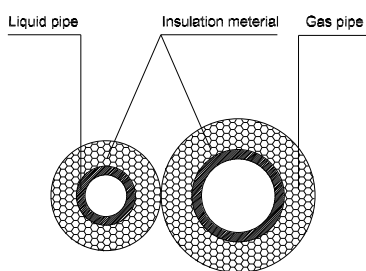

- The insulation material at the joint pipe shall be 5~10cm/1.97~3.97in longer than the gap of the insulation material.
- The insulation material at the joint pipe shall be inserted into the gap of the insulation material.
- The insulation material at the joint pipe shall be banded to the gas pipe and liquid pipe tightly.
- The linking part should be use glue to paste together

- Be sure not bind the insulation material over-tight, it may extrude out the air in the material to cause bad insulation and cause easy aging of the material.

### 9.2 Insulation of drainage pipe

#### 1. Operational procedure of refrigerant pipe insulation

Select the suitable pipe → insulation (except joint section) → piping layout and connection → drainage test → insulate the joint parts

#### 2. Purpose of drainage pipe insulation

The temperature of condensate drainage water is very low. If insulation is not enough, it shall form dew and cause leakage to damage the house decoration.

#### 3. Insulation material selection for drainage pipe

- The insulation material should be flame retardant material, the flame retardancy of the material should be selected according to the local law.
- Thickness of insulation layer is usually above 10mm/0.39in.
- Use specific glue to paste the seam of insulation material, and then bind with adhesive tape. The width of tape shall not be less than 5cm/1.97in. Make sure it is firm and avoid dew.

#### 4. Installation and highlights of insulation construction

- The single pipe should be insulated before connecting to another pipe, the joint part should be insulated after the drainage test.
- There should be no insulation gap between the insulation material.

## 10. Engineering of Electrical Wiring

### 1. Highlights of electrical wiring installation

- All field wiring construction should be finished by qualified electrician.
- Air conditioning equipment should be grounded according to the local electrical regulations.
- Current leakage protection switch should be installed.
- Do not connect the power wire to the terminal of signal wire.
- When power wire is parallel with signal wire, put wires to their own wire tube and remain at least 300mm/11.8in gap.
- According to table in indoor part named "the specification of the power" to choose the wiring, make sure the selected wiring not small than the data showing in the table.
- Select different colors for different wire according to relevant regulations.
- Do not use metal wire tube at the place with acid or alkali corrosion, adopt plastic wire tube to replace it.
- There must be not wire connect joint in the wire tube If joint is a must, set a connection box at the place.
- The wiring with different voltage should not be in one wire tube.
- Ensure that the color of the wires of outdoor and the terminal No. are same as those of indoor unit respectively.

Table: Minimum Cross-Sectional Area of Power and Signal Cables

Rated Current of Appliance (A)	AWG
≤ 6	18
6 - 10	16
10 - 16	14
16 - 25	12
25 - 32	10

## 11. Test Operation

**1. The test operation must be carried out after the entire installation has been completed.**

**2. Please confirm the following points before the test operation.**

- The indoor unit and outdoor unit are installed properly.
- Piping and wiring are properly connected.
- Ensure that there are no obstacles near the inlet and outlet of the unit that might cause poor performance or product malfunction.
- The refrigeration system does not leak.
- The drainage system is unimpeded and draining to a safe location.
- The heating insulation is properly installed.
- The grounding wires are properly connected
- The length of the piping and the added refrigerant stow capacity have been recorded.
- The power voltage is the correct voltage for the air conditioner.

CAUTION: Failure to perform the test run may result in unit damage, property damage or personal injury.

### 3. Test Run Instructions

1. Open both the liquid and gas stop valves.
2. Turn on the main power switch and allow the unit to warm up.
3. Set the air conditioner to COOL mode, and check the following points.

#### Indoor unit

- a. Ensure the remote control and its buttons work properly.
- b. Ensure the louvers move properly and can be changed using the remote control.
- c. Double check to see if the room temperature is being registered correctly.
- d. Ensure the indicators on the remote control and the display panel on the indoor unit work properly.
- e. Ensure the manual buttons on the indoor unit works properly.
- f. Check to see that the drainage system is unimpeded and draining smoothly.
- g. Ensure there is no vibration or abnormal noise during operation.

#### Outdoor unit

- a. Check to see if the refrigeration system is leaking.

- 
- b. Make sure there is no vibration or abnormal noise during operation.
  - c. Ensure the wind, noise, and water generated by the unit do not disturb your neighbors or pose a safety hazard.

#### 4. Drainage Test

##### For other types,

- a. Ensure the drainpipe flows smoothly. New buildings should perform this test before finishing the ceiling.
- b. Remove the test cover. Add 2,000ml of water to the tank through the attached tube.
- c. Turn on the main power switch and run the air conditioner in COOL mode.
- d. Listen to the sound of the drain pump to see if it makes any unusual noises.
- e. Check to see that the water is discharged. It may take up to one minute before the unit begins to drain depending on the drainpipe.
- f. Make sure that there are no leaks in any of the piping.
- g. Stop the air conditioner. Turn off the main power switch and reinstall the test cover.

##### For one-way cassette type,

- Before the test, make sure that the water discharge pipeline is smooth, and check that each connection is sealed properly.
  - Conduct the water discharge test in the new room before the ceiling is paved.
1. Connect the power supply, and set the air conditioner to operate in the cool mode.

Check the running sound of the drainage pump.

2. keep cool mode running at least 10 min.
3. Stop the air conditioner. Wait for three minutes, and then check if there is anything unusual. If the water discharge piping layout is not correct, the excessive water flow will cause the water level error and "EH OE" error code will be displayed on the display panel. There may even be water overflowing from the water pan.
4. Continue to add water until the alarm for excessive water levels is triggered. Check if the drainage pump drains water immediately. After three minutes, if the water level does not fall below the warning level, the unit will shut down.

At this time, you need to turn off the power supply, and drain away the accumulated water before you can turn on the unit normally.

5. Turn off the power supply, remove the water manually

using the drainage plug, and put the test cap back to the original place.

##### CAUTION:

The drainage plug at the bottom of the unit body is used to discharge accumulated water from the drain pan when the air conditioner malfunctions. When the air conditioner is operating normally, make sure the drainage plug is properly plugged to prevent water from leaking.



---

# Maintenance

## Contents

<b>1.</b>	<b>First Time Installation Check</b> .....	<b>2</b>
<b>2</b>	<b>Refrigerant Recharge</b> .....	<b>4</b>
<b>3</b>	<b>Re-Installation</b> .....	<b>5</b>
3.1	Indoor Unit.....	5
3.2	Outdoor Unit.....	7

## 1. First Time Installation Check

Air and moisture trapped in the refrigerant system affects the performance of the air conditioner by:

- Increasing pressure in the system.
- Increasing the operating current.
- Decreasing the cooling or heating efficiency.
- Congesting the capillary tubing due to ice build-up in the refrigerant circuit.
- Corroding the refrigerant system.

To prevent air and moisture from affecting the air conditioner's performance, the indoor unit, as well as the pipes between the indoor and outdoor unit, must be leak tested and evacuated.

### Leak test (soap water method)

Use a soft brush to apply soapy water or a neutral liquid detergent onto the indoor unit connections and outdoor unit connections. If there is gas leakage, bubbles will form on the connection.

### Air purging with vacuum pump

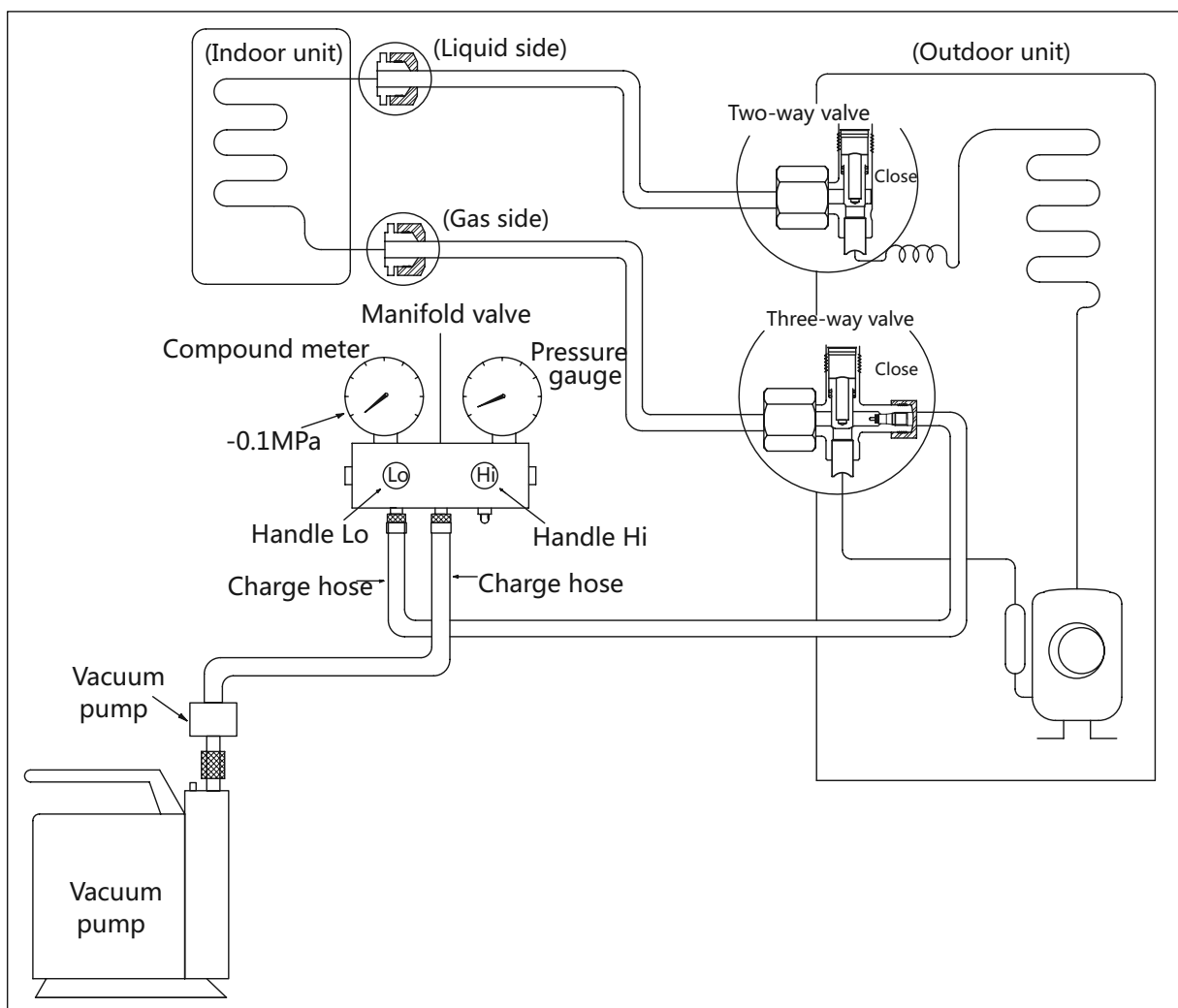

---

**Procedure:**

1. Tighten the flare nuts of the indoor and outdoor units, and confirm that both the 2- and 3-way valves are closed.
2. Connect the charge hose with the push pin of Handle Lo to the gas service port of the 3-way valve.
3. Connect another charge hose to the vacuum pump.
4. Fully open the Handle Lo manifold valve.
5. Using the vacuum pump, evacuate the system for 30 minutes.
  - a. Check whether the compound meter indicates -0.1 MPa (14.5 Psi).
    - If the meter does not indicate -0.1 MPa (14.5 Psi) after 30 minutes, continue evacuating for an additional 20 minutes.
    - If the pressure does not achieve -0.1 MPa (14.5 Psi) after 50 minutes, check for leakage.
- If the pressure successfully reaches -0.1 MPa (14.5 Psi), fully close the Handle Lo valve, then cease vacuum pump operations.
- b. Wait for 5 minutes then check whether the gauge needle moves after turning off the vacuum pump. If the gauge needle moves backward, check whether there is gas leakage.
6. Loosen the flare nut of the 3-way valve for 6 or 7 seconds and then tighten the flare nut again.
  - a. Confirm the pressure display in the pressure indicator is slightly higher than the atmospheric pressure.
  - b. Remove the charge hose from the 3-way valve.
7. Fully open the 2- and 3-way valves and tighten the cap of the 2- and 3-way valves.

## 2. Refrigerant Recharge

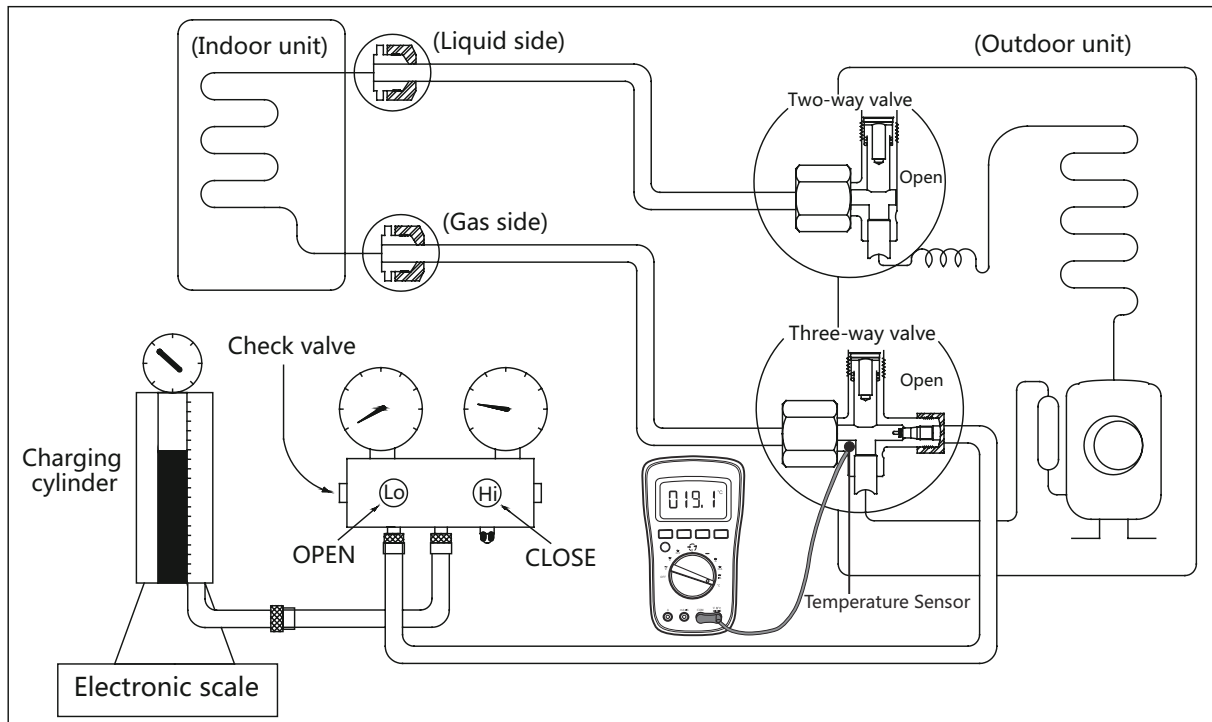

### Procedure:

1. Close both 2- and 3-way valves.
2. Slightly connect the Handle Lo charge hose to the 3-way service port.
3. Connect the charge hose to the valve at the bottom of the cylinder.
4. If the refrigerant is R410A/R32, invert the cylinder to ensure a complete liquid charge.
5. Open the valve at the bottom of the cylinder for 5 seconds to purge the air in the charge hose, then fully tighten the charge hose with push pin Handle Lo to the service port of 3-way valve..
6. Place the charging cylinder onto an electronic scale and record the starting weight.
7. Fully open the Handle Lo manifold valve, 2- and 3-way valves.
8. Operate the air conditioner in cooling mode to charge the system with liquid refrigerant.
9. When the electronic scale displays the correct weight (refer to the gauge and the pressure of the low side to confirm, the value of pressure refers to chapter Appendix), turn off the air conditioner, then disconnect the charge hose from the 3-way service port immediately..
10. Mount the caps of service port and 2- and 3-way valves.
11. Use a torque wrench to tighten the caps to a torque of 18 N.m.
12. Check for gas leakage.

## 3. Re-Installation

### 3.1 Indoor Unit

Collecting the refrigerant into the outdoor unit

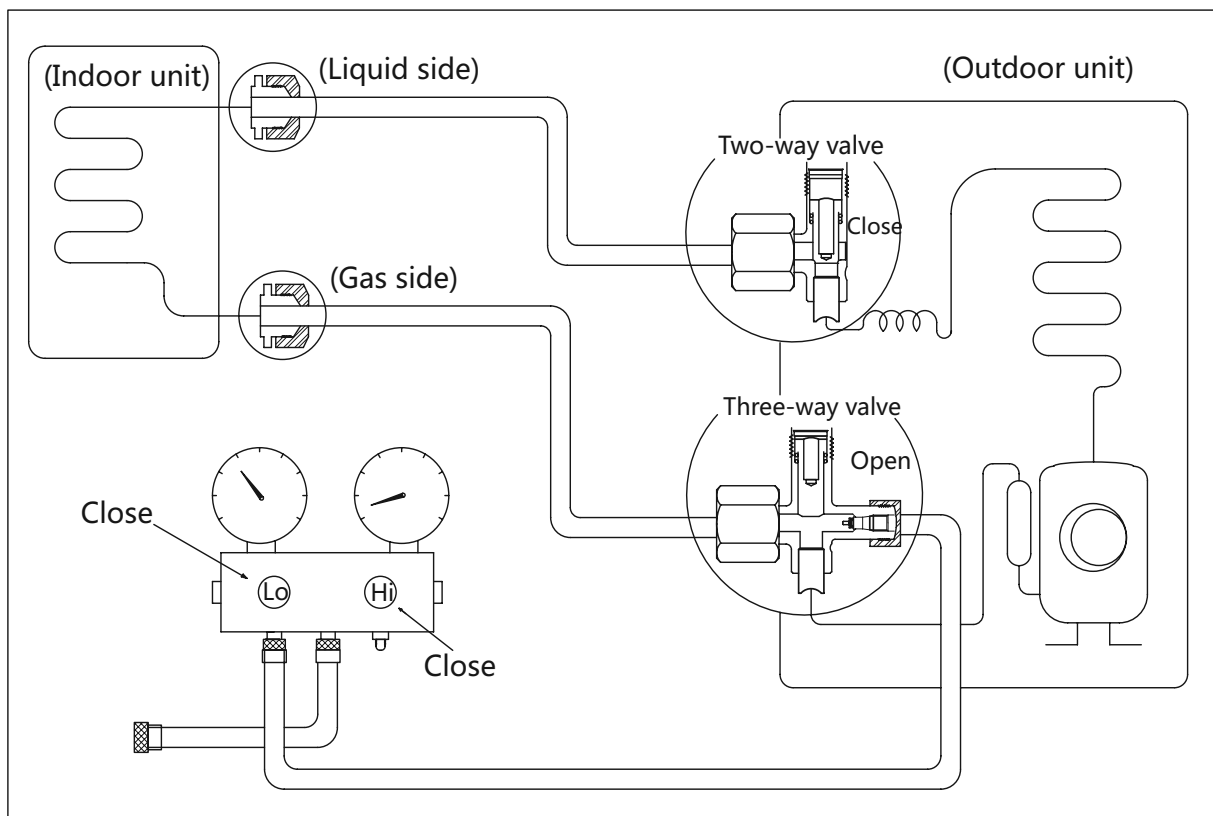

#### Procedure:

1. Confirm that the 2- and 3-way valves are opened.
2. Connect the charge hose with the push pin of Handle Lo to the 3-way valve's gas service port.
3. Open the Handle Lo manifold valve to purge air from the charge hose for 5 seconds and then close it quickly.
4. Close the 2-way valve.
5. Operate the air conditioner in cooling mode. Cease operations when the gauge reaches 0.1 MPa (14.5 Psi).
6. Close the 3-way valve so that the gauge rests between 0.3 MPa (43.5 Psi) and 0.5 MPa (72.5 Psi).
7. Disconnect the charge set and mount the caps of service port and 2- and 3-way valves.
8. Use a torque wrench to tighten the caps to a torque of 18 N.m.
9. Check for gas leakage.

## Air purging with vacuum pump

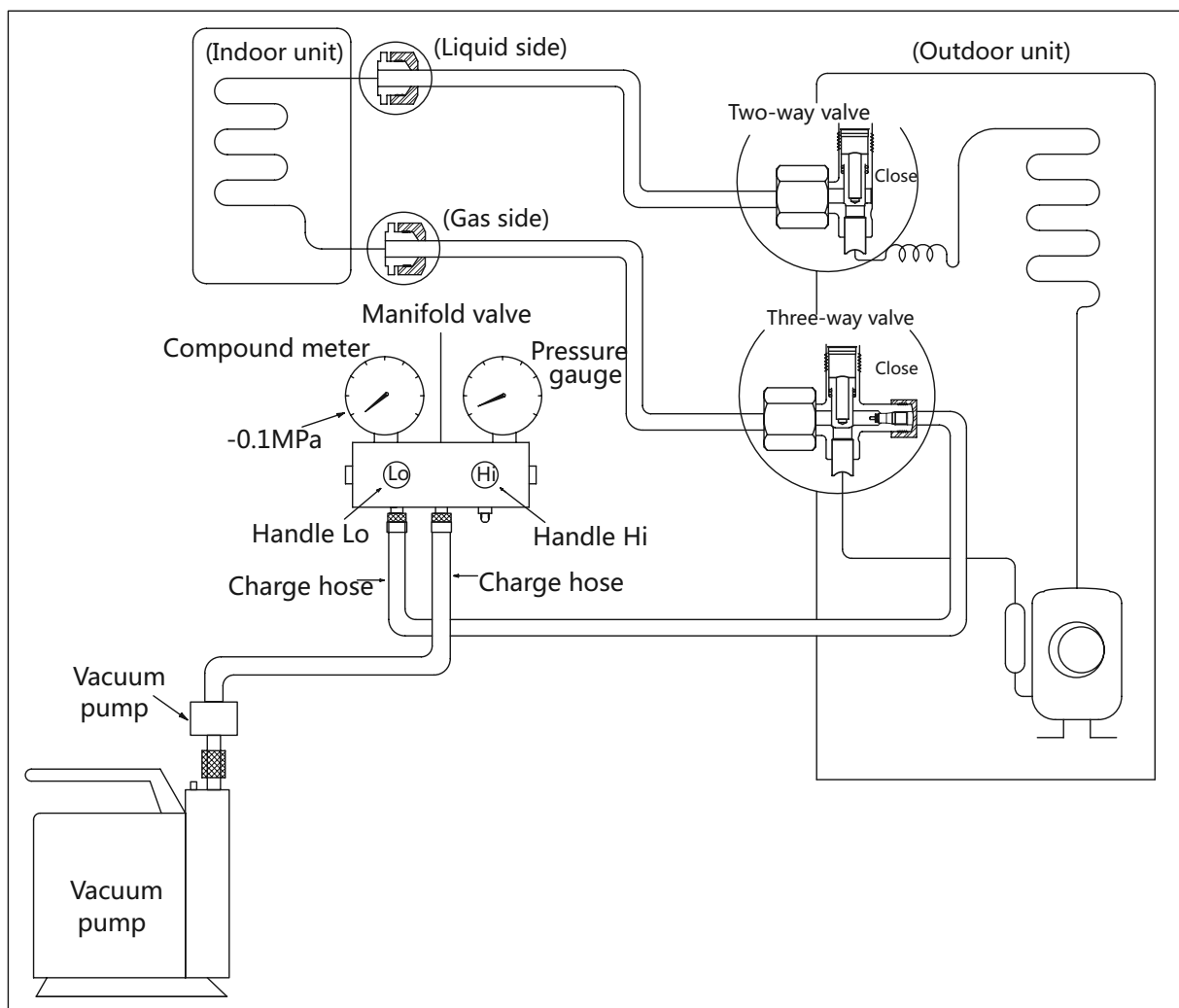

### Procedure:

1. Tighten the flare nuts of the indoor and outdoor units, and confirm that both the 2- and 3-way valves are closed.
2. Connect the charge hose with the push pin of Handle Lo to the gas service port of the 3-way valve.
3. Connect another charge hose to the vacuum pump.
4. Fully open the Handle Lo manifold valve.
5. Using the vacuum pump, evacuate the system for 30 minutes.
  - a. Check whether the compound meter indicates -0.1 MPa (14.5 Psi).
    - If the meter does not indicate -0.1 MPa (14.5 Psi) after 30 minutes, continue evacuating for an additional 20 minutes.
    - If the pressure does not achieve -0.1 MPa (14.5 Psi) after 50 minutes, check for leakage.
  - b. If the pressure successfully reaches -0.1 MPa (14.5 Psi), fully close the Handle Lo valve, then cease vacuum pump operations.
6. Loosen the flare nut of the 3-way valve for 6 or 7 seconds and then tighten the flare nut again.
  - a. Confirm the pressure display in the pressure indicator is slightly higher than the atmospheric pressure.
  - b. Remove the charge hose from the 3-way valve.
7. Fully open the 2- and 3-way valves and tighten the cap of the 2- and 3-way valves.

## 3.2 Outdoor Unit

### Evacuation for the whole system

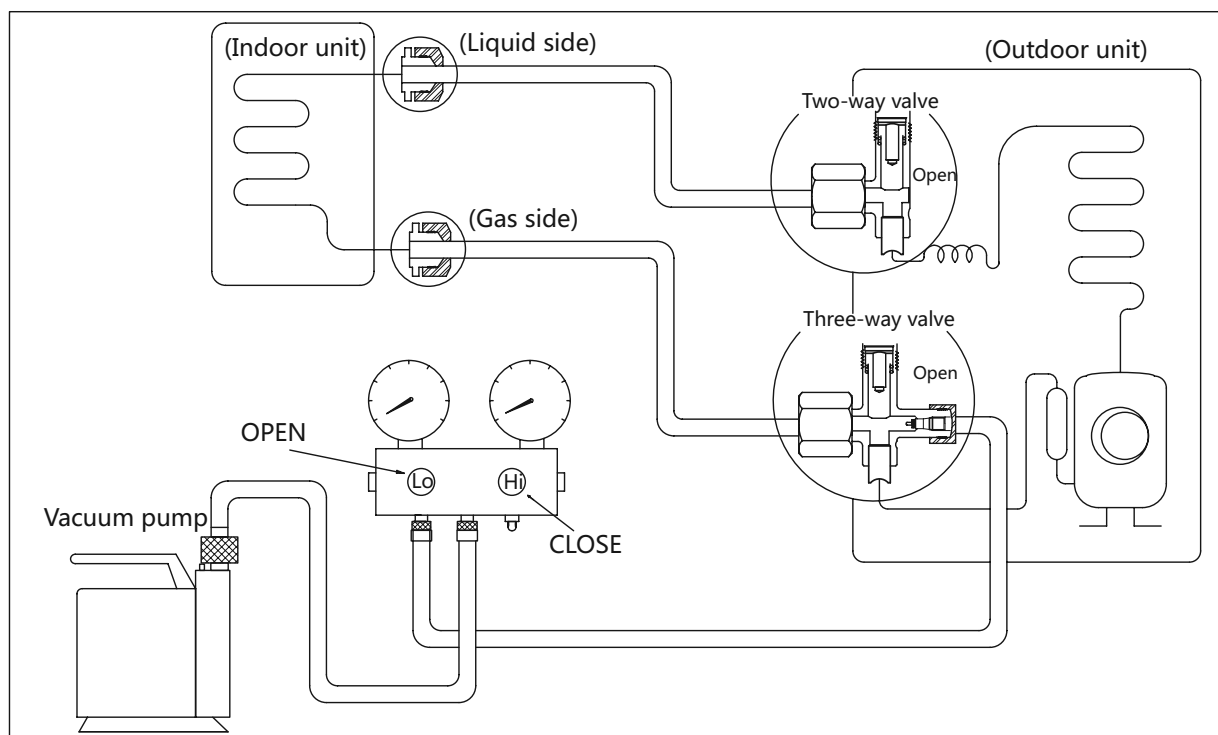

#### Procedure:

1. Confirm that the 2- and 3-way valves are opened.
2. Connect the vacuum pump to the 3-way valve's service port.
3. Evacuate the system for approximately one hour. Confirm that the compound meter indicates -0.1 MPa (14.5Psi).
4. Close the valve (Low side) on the charge set and turn off the vacuum pump.
5. Wait for 5 minutes then check whether the gauge needle moves after turning off the vacuum pump. If the gauge needle moves backward, check whether there is gas leakage.
6. Disconnect the charge hose from the vacuum pump.
7. Mount the caps of service port and 2- and 3-way valves.
8. Use a torque wrench to tighten the caps to a torque of 18 N.m.

## Refrigerant charging

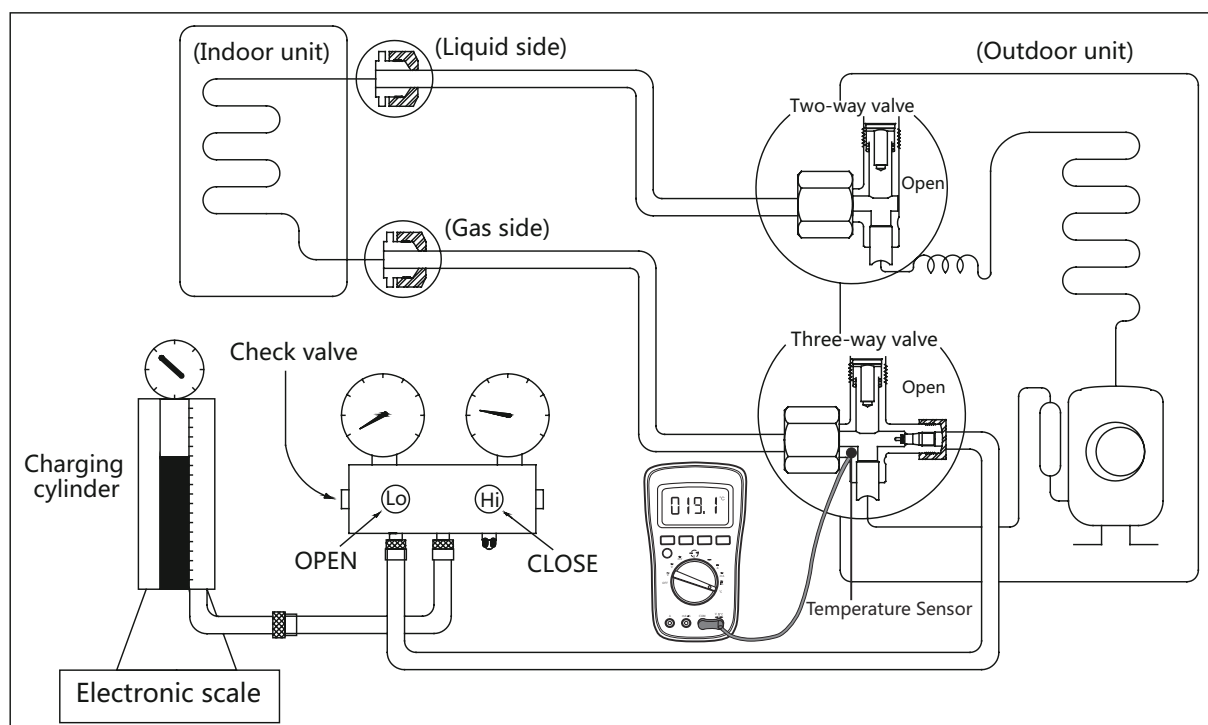

### Procedure:

1. Close both 2- and 3-way valves.
2. Slightly connect the Handle Lo charge hose to the 3-way service port.
3. Connect the charge hose to the valve at the bottom of the cylinder.
4. If the refrigerant is R410A/R32, invert the cylinder to ensure a complete liquid charge.
5. Open the valve at the bottom of the cylinder for 5 seconds to purge the air in the charge hose, then fully tighten the charge hose with push pin Handle Lo to the service port of 3-way valve..
6. Place the charging cylinder onto an electronic scale and record the starting weight.
7. Fully open the Handle Lo manifold valve, 2- and 3-way valves.
8. Operate the air conditioner in cooling mode to charge the system with liquid refrigerant.
9. When the electronic scale displays the correct weight (refer to the gauge and the pressure of the low side to confirm, the value of pressure refers to chapter Appendix), turn off the air conditioner, then disconnect the charge hose from the 3-way service port immediately..
10. Mount the caps of service port and 2- and 3-way valves.
11. Use a torque wrench to tighten the caps to a torque of 18 N.m.
12. Check for gas leakage.

**Note: 1. Mechanical connectors used indoors shall comply with local regulations.**

**2. When mechanical connectors are reused indoors, sealing parts shall be renewed. When flared joints are reused indoors, the flare part shall be re-fabricated.**



---

# Product Features

## Contents

<b>1.</b>	<b>Display Function .....</b>	<b>2</b>
<b>2</b>	<b>Safety Features .....</b>	<b>5</b>
<b>3.</b>	<b>Basic Functions.....</b>	<b>6</b>
3.1	Table .....	6
3.2	Abbreviation.....	7
3.3	Fan Mode.....	7
3.4	Cooling Mode .....	7
3.5	Heating Mode(Heat Pump Units) .....	8
3.6	Auto-mode.....	9
3.7	Drying Mode .....	10
3.8	Forced Operation Function .....	10
3.9	Timer Function .....	10
3.10	ECO Function .....	10
3.11	Auto-Restart Function.....	10
3.12	Drain Pump Control.....	10
<b>4.</b>	<b>Optional Functions .....</b>	<b>11</b>
<b>5.</b>	<b>Remote Controller Functions .....</b>	<b>12</b>
5.1	Infrared Wireless Remote Controller.....	12
5.2	LCD Wired Remote Controller .....	16
5.3	Centralized Controller .....	32

# 1. Display Function

Floor Ceiling Type

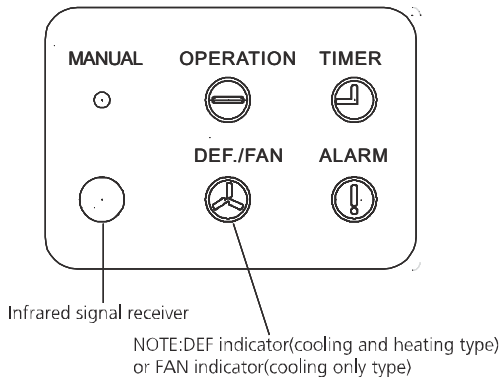

Display 1

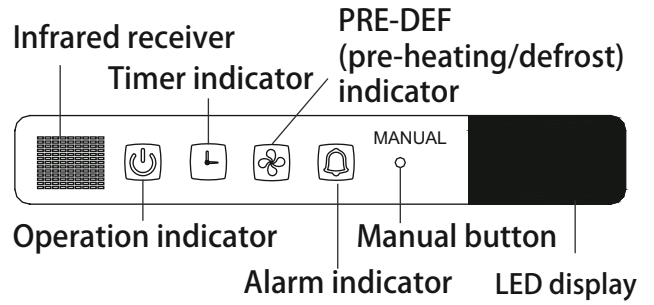

Display 2

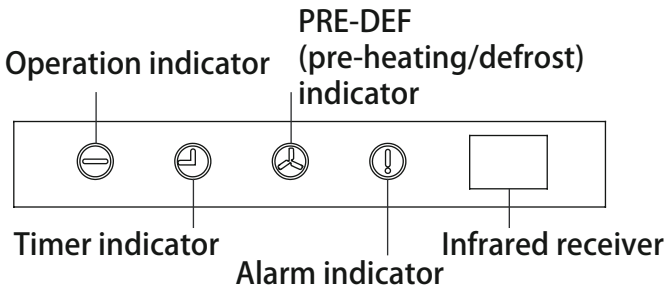

Display 3

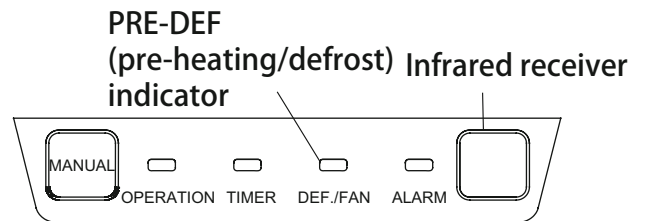

Display 4

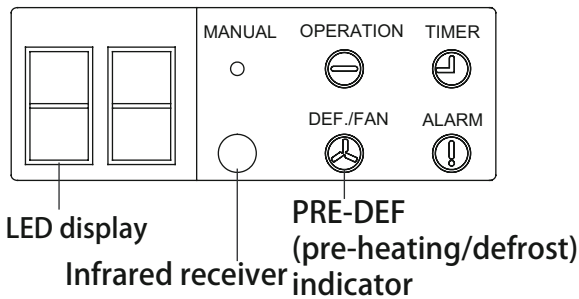

Display 5

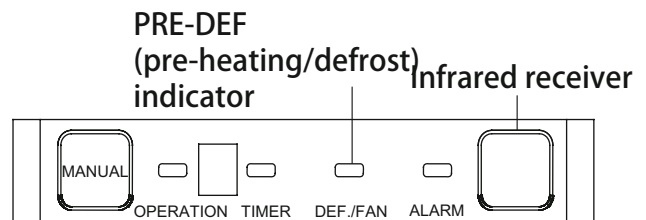

Display 6

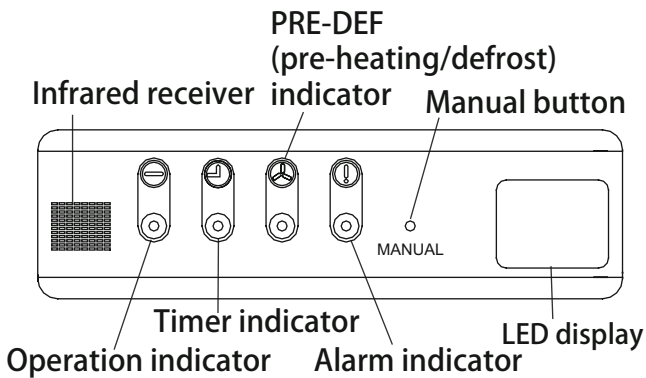

Display 7

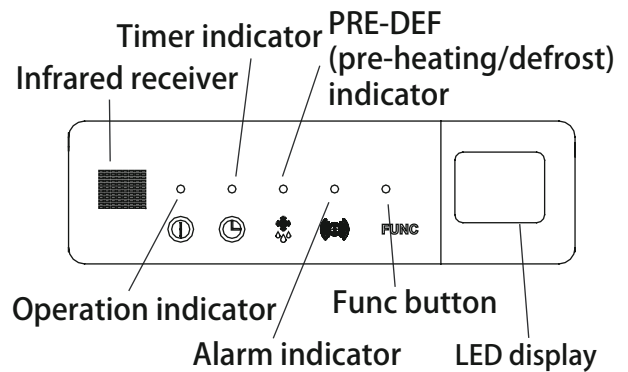

Display 8

## New 4-way Cassette Type & New Compact Cassette Type

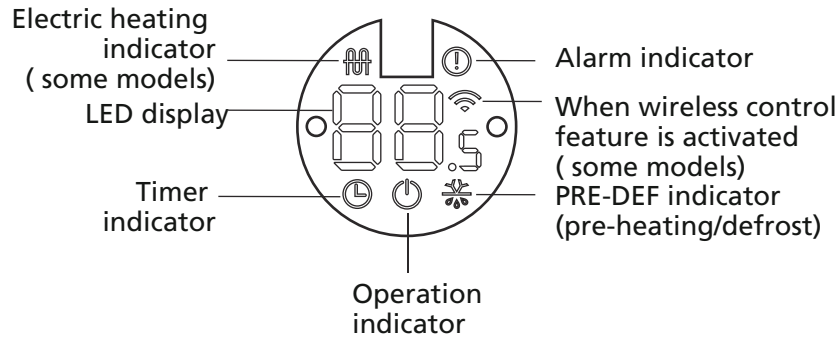

## 1-way Cassette Type

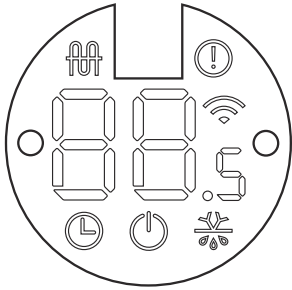

- "⌘" " when Electric heating feature is activated (Not available for this unit).
- "🕒" " when TIMER is set.
- "🔌" " when the unit is on.
- "⚠️" " Alarm indicator.
- "📶" " when Wireless Control feature is activated (some units).
- "❄️" " when pre-heating/defrost feature is activated.
- "88.5" " Displays temperature, operation feature and Error codes.
- "FP" " when 8°C heating feature is turned on.
- "CL" " when Active Clean feature is turned on.
- "AP" " when WiFi module enters AP mode (some units).
- "FC" " when Forced cooling feature is turned on.
- "CF" " Filter cleaning reminder.

## Duct Type

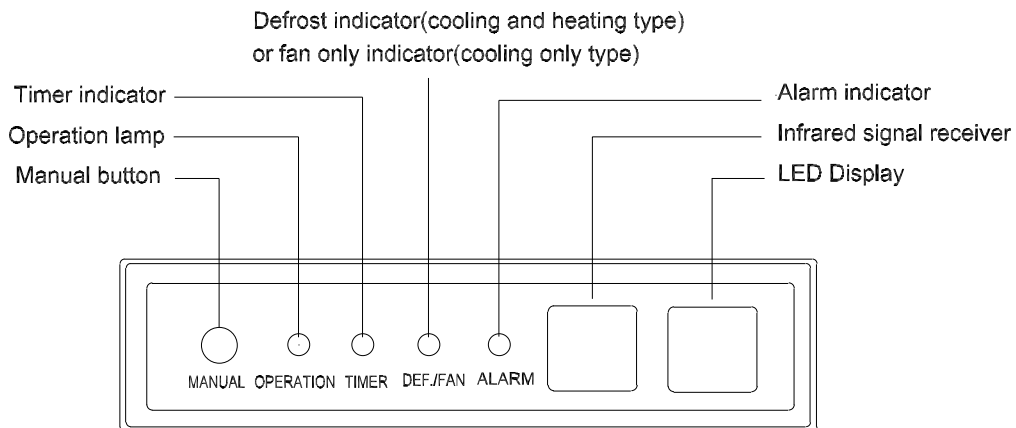

---

## Compact Cassette Type

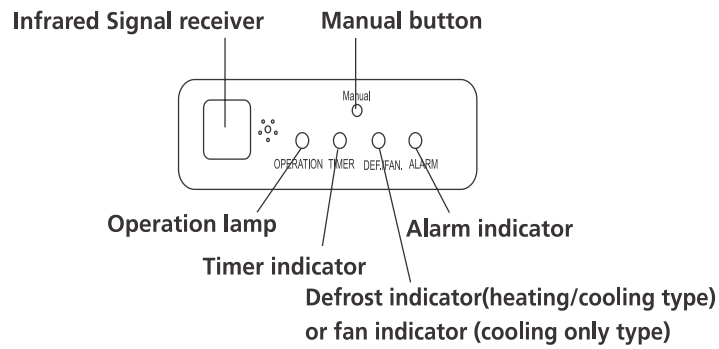

## Console Type

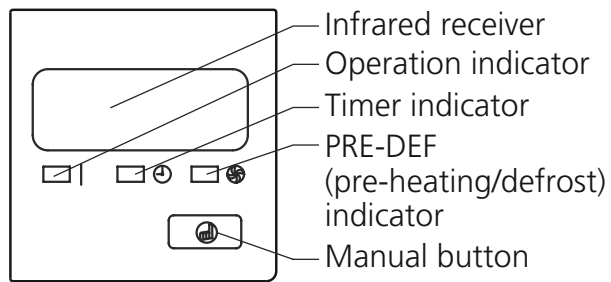



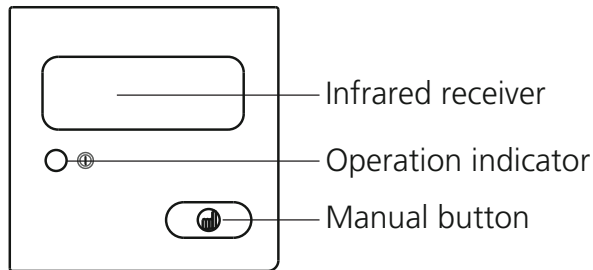



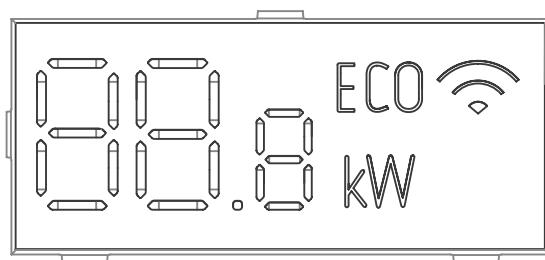

Display 1



Display 2

## New Console Type



Display		Function
ECO		ECO function (available on select units only)
		When Wireless Control feature is activated (some units)
	Temperature value	Temperature
		Timer ON is set. Activation of Swing, Boost, Silence or UV-C lamp
		Timer OFF is set. Cancellation of Swing, Boost, Silence or UV-C lamp
		Defrost
		Active Clean
		Heating in room temperature under 8°C(46°F)

**Note:** Please select the display function according to your purchase product.

---

## 2. Safety Features

### Compressor three-minute delay at restart

Compressor functions are delayed for up to ten seconds upon the first startup of the unit, and are delayed for up to three minutes upon subsequent unit restarts.

### Automatic shutoff based on discharge temperature

If the compressor discharge temperature exceeds a certain level for nine seconds, the compressor ceases operation.

### Inverter module protection

The inverter module has an automatic shutoff mechanism based on the unit's current, voltage, and temperature. If automatic shutoff is initiated, the corresponding error code is displayed on the indoor unit and the unit ceases operation.

### Indoor fan delayed operation

- When the unit starts, the louver is automatically activated and the indoor fan will operate after a period of setting time or the louver is in place.
- If the unit is in heating mode, the indoor fan is regulated by the anti-cold wind function.

### Compressor preheating

Preheating is automatically activated when T4 sensor is lower than setting temperature.

### Sensor redundancy and automatic shutoff

- If one temperature sensor malfunctions, the air conditioner continues operation and displays the corresponding error code, allowing for emergency use.
- When more than one temperature sensor is malfunctioning, the air conditioner ceases operation.

---

### 3. Basic Functions

#### 3.1 Table

Functions		Cooling Mode&Heating mode		Heating Mode				Auto mode		
		Outdoor Fan Control		Defrosting Mode		Anti-cold Air Function				
Cases		Case 1: Compressor Frequency and T4	Case 2:T4	Case 1	Case 2	Case 1	Case 2	Case 1	Case 2	Case 3
Models	9k~18k	✓			✓	✓				✓

Note: The detailed description of case 1 or case 2 is shown in the following function sections(from 3.4 to 3.6).

## 3.2 Abbreviation

Unit element abbreviations

Abbreviation	Element
T1	Indoor room temperature
T2	Coil temperature of evaporator
T3	Coil temperature of condenser
T4	Outdoor ambient temperature
TP	Compressor discharge temperature
Tsc	Adjusted setting temperature
CDIFTEMP	Cooling shutdown temperature
HDIFTEMP2	Heating shutdown temperature
TCDE1	Exit defrost temperature1
TCDE2	Exit defrost temperature2 (maintain for a period of time )
TIMING_DEFROST_TIME	Enter defrost time

In this manual, such as CDIFTEMP, HDIFTEMP2, TCDE1, TCDE2, TIMING\_DEFROST\_TIME...etc., they are well-setting parameter of EEPROM.

## 3.3 Fan Mode

When fan mode is activated:

- The outdoor fan and compressor are stopped.
- Temperature control is disabled and no temperature setting is displayed.
- The indoor fan speed can be set to 1%~100%, or low, medium, high and auto.
- The louver operations are identical to those in cooling mode.
- Auto fan: In fan-only mode, AC operates the same as auto fan in cooling mode with the temperature set at 24°C(75°F).

## 3.4 Cooling Mode

### 3.4.1 Compressor Control

Reach the configured temperature:

- 1) When the compressor runs continuously for less than 120 minutes.
  - If the following conditions are satisfied, the compressor ceases operation.
    - Calculated frequency(fb) is less than minimum limit frequency(FminC).
    - Compressor runs at FminC more than ten minutes.
    - T1 is lower than or equal to (Tsc-CDIFTEMP-0.5°C/0.9°F)
- 2) When the compressor runs continuously for more than

120 minutes.

- If the following conditions are satisfied, the compressor ceases operation.
  - Calculated frequency(fb) is less than minimum limit frequency(FminC).
  - Compressor runs at FminC more than 10 minutes.
  - When T1 is lower than or equal to (Tsc-CDIFTEMP).

Note: CDIFTEMP is EEPROM setting parameter. It is 2°C(35.6°F) usually.

- 3) If one of the following conditions is satisfied, not judge protective time.
  - Compressor running frequency is more than test frequency.
  - When compressor running frequency is equal to test frequency, T4 is more than 15°C(59 °F) or T4 fault.
  - Change setting temperature.
  - Turning on/off turbo or sleep function
  - Various frequency limit shutdown occurs.

### 3.4.2 Indoor Fan Control

- 1) In cooling mode, the indoor fan operates continuously. The fan speed can be set to 1%-100%, or low, medium, high and auto.
- 2) Auto fan action in cooling mode:
  - Descent curve
    - When T1-Tsc is lower than or equal to 3.5°C/6.3°F, fan speed reduces to 80%(High);
    - When T1-Tsc is lower than or equal to 1°C/1.8°F,, fan speed reduces to 60%(Medium);
    - When T1-Tsc is lower than or equal to 0.5°C/0.9°F, fan speed reduces to 40%(Low);
    - When T1-Tsc is lower than or equal to 0°C/0°F, fan speed reduces to 20%(Low);;
    - When T1-Tsc is lower than or equal to -0.5°C/-0.9°F, fan speed reduces to 1%(Low);.

- Rise curve
  - When T1-Tsc is higher than 0°C/0°F, fan speed increases to 20%(Low);;
  - When T1-Tsc is higher than 0.5°C/0.9°F, fan speed increases to 40%(Low);
  - When T1-Tsc is higher than 1°C/1.8°F,, fan speed increases to 60%(Medium);
  - When T1-Tsc is higher than 1.5°C/2.7°F, fan speed increases to 80%(High);
  - When T1-Tsc is higher than 4°C/7.2°F, fan speed increases to 100%(High).

### 3.4.3 Outdoor Fan Control

#### Case 1:

- The outdoor unit will be run at different fan speed according to T4 and compressor frequency.



- For different outdoor units, the fan speeds are different.

**Case 2:**

- The outdoor unit will be run at different fan speed according to T4.
- For different outdoor units, the fan speeds are different.

**3.4.4 Condenser Temperature Protection**

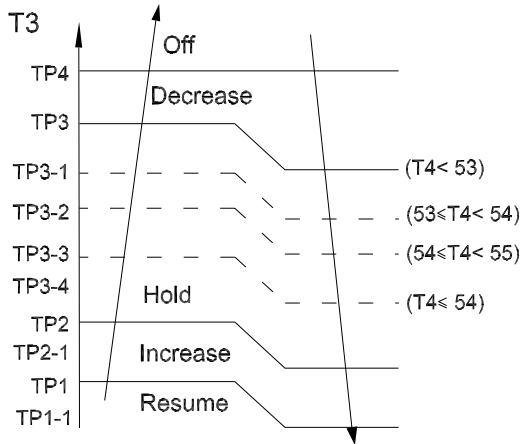

When the condenser temperature exceeds a configured value, the compressor ceases operation.

**3.4.5 Evaporator Temperature Protection**

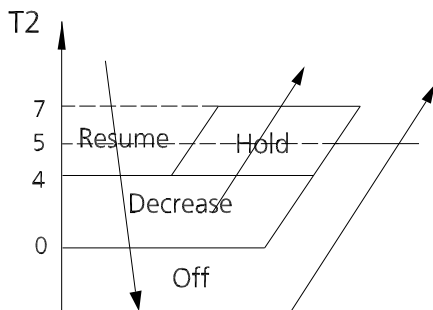

- Off: Compressor stops.
- Decrease: Decrease the running frequency to the lower level per 1 minute.
- Hold: Keep the current frequency.
- Resume: No limitation for frequency.

**3.5 Heating Mode(Heat Pump Units)**

**3.5.1 Compressor Control**

- 1) Reach the configured temperature
  - If the following conditions are satisfied, the compressor ceases operation.
    - Calculated frequency(fb) is less than minimum limit frequency(FminH).
    - Compressor runs at FminH more than 10 minutes.
    - T1 is higher than or equal to Tsc+ HDIFTEMP2.

Note: HDIFTEMP2 is EEPROM setting parameter. It is 2°C(35.6°F) usually.

- If one of the following conditions is satisfied, not judge protective time.
    - Compressor running frequency is more than test frequency.
    - Compressor running frequency is equal to test frequency, T4 is more than 15°C(59 °F) or T4 fault.
    - Change setting temperature.
    - Turning on/off turbo or sleep function
- 2) When the current is higher than the predefined safe value, surge protection is activated, causing the compressor to cease operations.

**3.5.2 Indoor Fan Control:**

- 1) In heating mode, the indoor fan operates continuously. The fan speed can be set to 1%-100%, or low, medium, high and auto.
  - Anti-cold air function
    - If the temperature difference of T2 changes during auto fan and causes the fan speed to change, run the current fan speed for 30 seconds first, the default interval is the interval before the fan speed changes, and then judge T2 according to the current interval after 30 seconds to get the final anti-cold air interval.

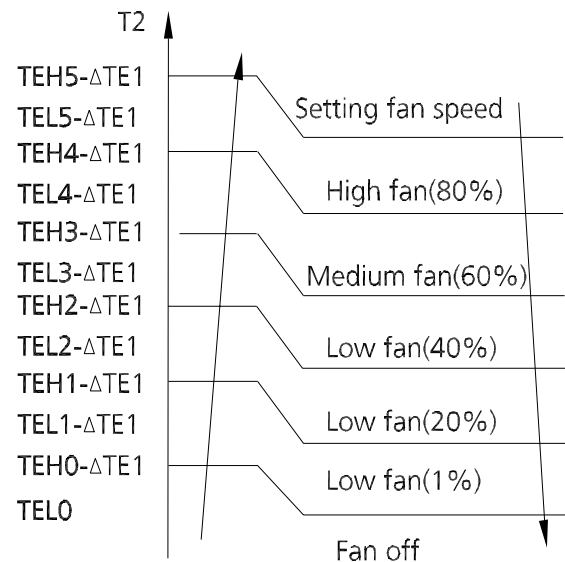

**Case 1:**

$T1 \geq 19^{\circ}\text{C}(66.2^{\circ}\text{F})$	$\Delta TE1=0$
$15^{\circ}\text{C}(59^{\circ}\text{F}) \leq T1 < 19^{\circ}\text{C}(66.2^{\circ}\text{F})$	$\Delta TE1=19^{\circ}\text{C}-T1$ ( $34.2^{\circ}\text{F}-T1$ )
$T1 < 15^{\circ}\text{C}(59^{\circ}\text{F})$	$\Delta TE1=4^{\circ}\text{C}(7.2^{\circ}\text{F})$

**Case 2:  $\Delta TE1=0$**

- 2) Auto fan action in heating mode:

- Rise curve
  - When T1-Tsc is higher than  $-1.5^{\circ}\text{C}/-2.7^{\circ}\text{F}$ , fan speed reduces to 80%(High);
  - When T1-Tsc is higher than  $0^{\circ}\text{C}/0^{\circ}\text{F}$ , fan speed reduces to 60%(Medium);
  - When T1-Tsc is higher than  $0.5^{\circ}\text{C}/0.9^{\circ}\text{F}$ , fan speed reduces to 40%(Low);
  - When T1-Tsc is higher than  $1^{\circ}\text{C}/1.8^{\circ}\text{F}$ , fan speed reduces to 20%(Low).
- Descent curve
  - When T1-Tsc is lower than or equal to  $0.5^{\circ}\text{C}/0.9^{\circ}\text{F}$ , fan speed increases to 40%(Low);
  - When T1-Tsc is lower than or equal to  $0^{\circ}\text{C}/0^{\circ}\text{F}$ , fan speed increases to 60%(Medium);
  - When T1-Tsc is lower than or equal to  $-1.5^{\circ}\text{C}/-2.7^{\circ}\text{F}$ , fan speed increases to 80%(high);
  - When T1-Tsc is lower than or equal to  $-3^{\circ}\text{C}/-5.4^{\circ}\text{F}$ , fan speed increases to 100%(High).

### 3.5.3 Outdoor Fan Control:

#### Case 1:

- The outdoor unit will be run at different fan speed according to T4 and compressor frequency.
- For different outdoor units, the fan speeds are different.

#### Case 2:

- The outdoor unit will be run at different fan speed according to T4.
- For different outdoor units, the fan speeds are different.

### 3.5.4 Defrosting mode

- The unit enters defrosting mode according to the temperature value of T3 and T4 as well as the compressor running time.
- In defrosting mode, the compressor continues to run, the indoor and outdoor motor will cease operation, the defrost light of the indoor unit will turn on, and the "df" symbol is displayed.
- If any one of the following conditions is satisfied, defrosting ends and the machine switches to normal heating mode:
  - T3 rises above TCDE1.
  - T3 maintained above TCDE2 for 80 seconds.
  - Unit runs for 15 minutes consecutively in defrosting mode.
- If T4 is lower than or equal to  $-22^{\circ}\text{C}/(-7.6^{\circ}\text{F})$  and compressor running time is more than TIMING\_DEFROST\_TIME, if any one of the following conditions is satisfied, defrosting ends and the machine switches to normal heating mode:
  - Unit runs for 10 minutes consecutively in defrosting mode.

- T3 rises above  $10^{\circ}\text{C}/50^{\circ}\text{F}$ .

The following conditions apply only to certain models, see table in section 3.1 for details.

#### Case 1:

- T3 is lower than  $3^{\circ}\text{C}(37.4^{\circ}\text{F})$  and compressor running time is more than 120 minutes, at this time, if T3 is lower than  $\text{TCDI1}+4^{\circ}\text{C}(39.2^{\circ}\text{F})$  for 3 minutes, the unit enters defrosting mode. If any one of the following conditions is satisfied, defrosting ends and the machine switches to normal heating mode:
  - T3 rises above  $\text{TCDE1}+4^{\circ}\text{C}/7.2^{\circ}\text{F}$ .
  - T3 maintained above  $\text{TCDE2}+4^{\circ}\text{C}/7.2^{\circ}\text{F}$  for 80 seconds.
  - Unit runs for 15 minutes consecutively in defrosting mode.

#### Case 2:

- If any one of the following conditions is satisfied, the unit enters defrosting mode
  - If T3 or T4 is lower than  $-3^{\circ}\text{C}$  for 30 seconds,  $\text{Ts}-\text{T1}$  is lower than  $5^{\circ}\text{C}$  and compressor running time is more than  $\text{EE\_TIME\_DEFROST7}$ .
  - If T3 or T4 is lower than  $-3^{\circ}\text{C}$  for 30 seconds and compressor running time is more than  $\text{EE\_TIME\_DEFROST7}+30$  minutes.
- If any one of the following conditions is satisfied, defrosting ends and the machine switches to normal heating mode:
  - T3 rises above  $\text{TCDE1}+4^{\circ}\text{C}/7.2^{\circ}\text{F}$ .
  - T3 maintained above  $\text{TCDE2}+4^{\circ}\text{C}/7.2^{\circ}\text{F}$  for 80 seconds.
  - Unit runs for 15 minutes consecutively in defrosting mode.

### 3.5.5 Evaporator Coil Temperature Protection

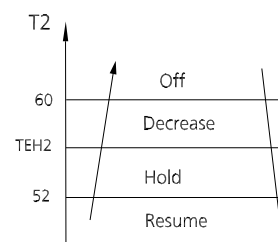

- Off: Compressor stops.
- Decrease: Decrease the running frequency to the lower level per 20 seconds.
- Hold: Keep the current frequency.
- Resume: No limitation for frequency.

### 3.6 Auto-mode

- This mode can be selected with the remote controller and the temperature setting can be adjusted between 16°C~30°C.

Case 1:

- In auto mode, the machine selects cooling, heating, or fan-only mode on the basis of  $\Delta T$  ( $\Delta T = T1 - Ts$ ).

$\Delta T$	Running mode
$\Delta T > 2^{\circ}\text{C}(3.6^{\circ}\text{F})$	Cooling
$-3^{\circ}\text{C}(-5.4^{\circ}\text{F}) \leq \Delta T \leq 2^{\circ}\text{C}(3.6^{\circ}\text{F})$	Fan-only
$\Delta T < -3^{\circ}\text{C}(-5.4^{\circ}\text{F})$	Heating*

Heating\*: In auto mode, cooling only models run the fan

- Indoor fan will run at auto fan speed.
- The louver operates same as in relevant mode.
- If the machine switches mode between heating and cooling, the compressor will keep stopping for certain time and then choose mode according to  $\Delta T$ .

Case 2:

In auto mode, the machine selects cooling, heating or fan-only mode on the basis of  $T1, Ts$  and  $T4$ .

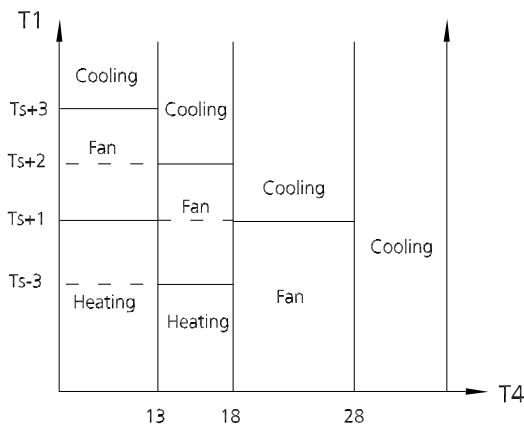

Case 3:

In auto mode, the machine selects cooling, heating or fan-only mode on the basis of  $T1, Ts, T4$  and relative humidity( $\phi$ ).

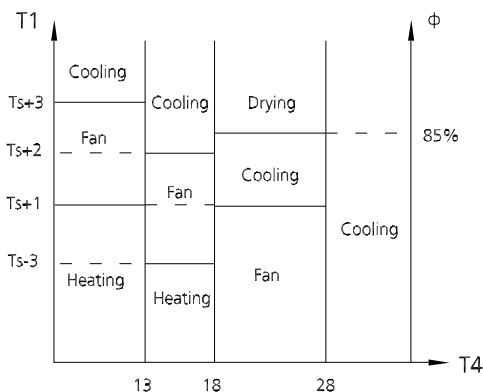

### 3.7 Drying mode

- In drying mode, AC operates the same as auto fan in cooling mode.
- All protections are activated and operate the same as they do that in cooling mode.
- Low Room Temperature Protection

If the room temperature is lower than 10°C/50°F, the compressor ceases operations and does not resume until room temperature exceeds 12°C/53.6°F.

### 3.8 Forced operation function

Press the AUTO/COOL button, the AC will run as below sequence:

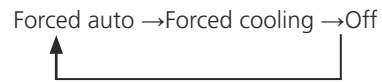

- Forced cooling mode:

The compressor and outdoor fan continue to run and the indoor fan runs at breeze speed. After running for 30 minutes, the AC will switch to auto mode with a preset temperature of 24°C(76°F).

- Forced auto mode:

Forced auto mode operates the same as normal auto mode with a preset temperature of 24°C(76°F).

- The unit exits forced operation when it receives the following signals:

- Switch off
- Changes in:
  - mode
  - fan speed
  - sleep mode
  - Follow me

### 3.9 Timer Function

- The timing range is 24 hours.
- Timer On. The machine turns on automatically at the preset time.
- Timer Off. The machine turns off automatically at the preset time.
- Timer On/Off. The machine turns on automatically at the preset On Time, and then turns off automatically at the preset Off Time.
- Timer Off/On. The machine turns off automatically at the preset Off Time and then turns on automatically at the preset On Time.
- The timer does not change the unit operation mode. If the unit is off now, it does not start up immediately after the "timer off" function is set. When the setting time is reached, the timer LED switches off and the unit running mode remains unchanged.
- The timer uses relative time, not clock time

---

### 3.10 Sleep function

- The sleep function is available in cooling, heating, or auto mode.
- The operational process for sleep mode is as follows:
  - When cooling, the temperature rises 1°C/1.8°F (to not higher than 30°C/86°F) every hour. After 2 hours, the temperature stops rising and the indoor fan is fixed at low speed.
  - When heating, the temperature decreases 1°C/1.8°F (to not lower than 16°C/60.8°F) every hour. After 2 hours, the temperature stops decreasing and the indoor fan is fixed at low speed. Anti-cold wind function takes priority.
- The operating time for sleep mode is 8 hours, after which, the unit exits this mode.
- The timer setting is available in this mode.

### 3.11 Auto-Restart function

- The indoor unit has an auto-restart module that allows the unit to restart automatically. The module automatically stores the current settings and in the case of a sudden power failure, will restore those setting automatically within 3 minutes after power returns.

---

## 4. Optional Functions

### 4.1 8°C Heating(Heat pump units)

In heating mode, the temperature can be set to as low as 8°C, preventing the indoor area from freezing if unoccupied during severe cold weather.

### 4.2 Follow me

- If you press “Follow Me” on the remote, the indoor unit will beep. This indicates the follow me function is active.
- Once active, the remote control will send a signal every 3 minutes, with no beeps. The unit automatically sets the temperature according to the measurements from the remote control.
- The unit will only change modes if the information from the remote control makes it necessary, not from the unit’s temperature setting.
- If the unit does not receive a signal for 7 minutes or you press “Follow Me,” the function turns off. The unit regulates temperature based on its own sensor and settings.

### 4.3 Silence

- Press “Silence” or keep pressing Fan button for more than 2 seconds on the remote control to enable the SILENCE function. While this function is active, the compressor frequency is maintained at a lower level than F3. The indoor unit will run at faint breeze(1%), which reduces noise to the lowest possible level.
- When match with multi outdoor unit, this function is disabled.

### 4.4 ECO Function

- Used to enter the energy efficient mode.
  - Under cooling mode, press ECO button, the remote controller will adjust the temperature automatically to 24°C/75°F, fan speed of Auto to save energy (but only if the set temperature is less than 24°C/75°F). If the set temperature is more than 24°C/75°F and 30°C/86°F, press the ECO button, the fan speed will change to Auto, the set temperature will remain unchanged.
- When pressing the ECO button, or modifying the mode or adjusting the set temperature to less than 24°C/75°F, the AC will quit the ECO operation.
- Operation time in ECO mode is 8 hours. After 8 hours the AC quits this mode.

### 4.5 Electrical energy consumption control function (Optional)

Press the “Gear” button on remote controller to enter the energy efficient mode in a sequence of following:

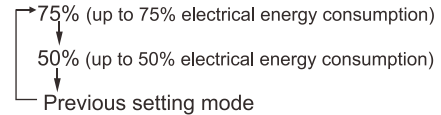

Turn off the unit or activate ECO, sleep, Super cool, 8°C Heating, Silence or self clean function will quit this function.

### 4.6 Breeze Away function (for some models)

- This feature avoids direct airflow blowing on the body and makes you feel indulging in silky coolness.
- NOTE: This feature is available under cooling mode, fan-only mode and drying mode.

### 4.7 Active Clean function

- The Active Clean Technology washes away dust, mold, and grease that may cause odors when it adheres to the heat exchanger by automatically freezing and then rapidly thawing the frost. The internal wind wheel then keeps operating to blow-dry the evaporator, thus preventing the growth of mold and keeping the inside clean.
- When this function is turned on, the indoor unit display window appears “CL”, after 20 to 45 minutes, the unit will turn off automatically and cancel Active Clean function.

## 5. Remote Controller Functions

### 5.1 Infrared Wireless Remote Controller

#### 5.1.1 RG10A(B2S)/BGEF (Standard for some units)

##### Remote Controller Specifications

Model	RG10A(B2S)/BGEF
Rated Voltage	3.0V (Dry batteries R03/LR03×2)
Reaching Distance	8m
Environment Temperature Range	-5°C~60°C(23°F~140°F)

##### Buttons and Functions

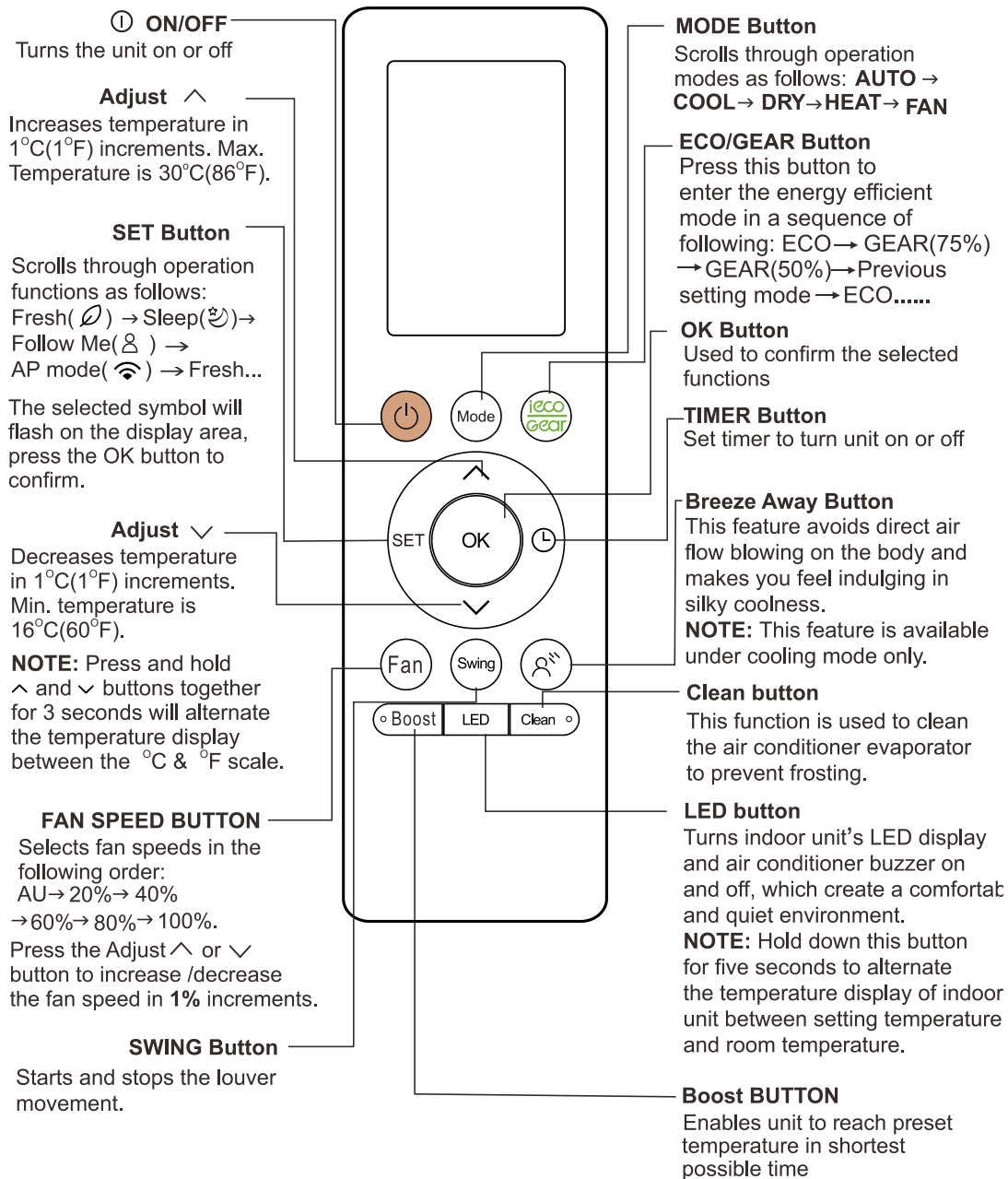

## Remote LCD Screen Indicators

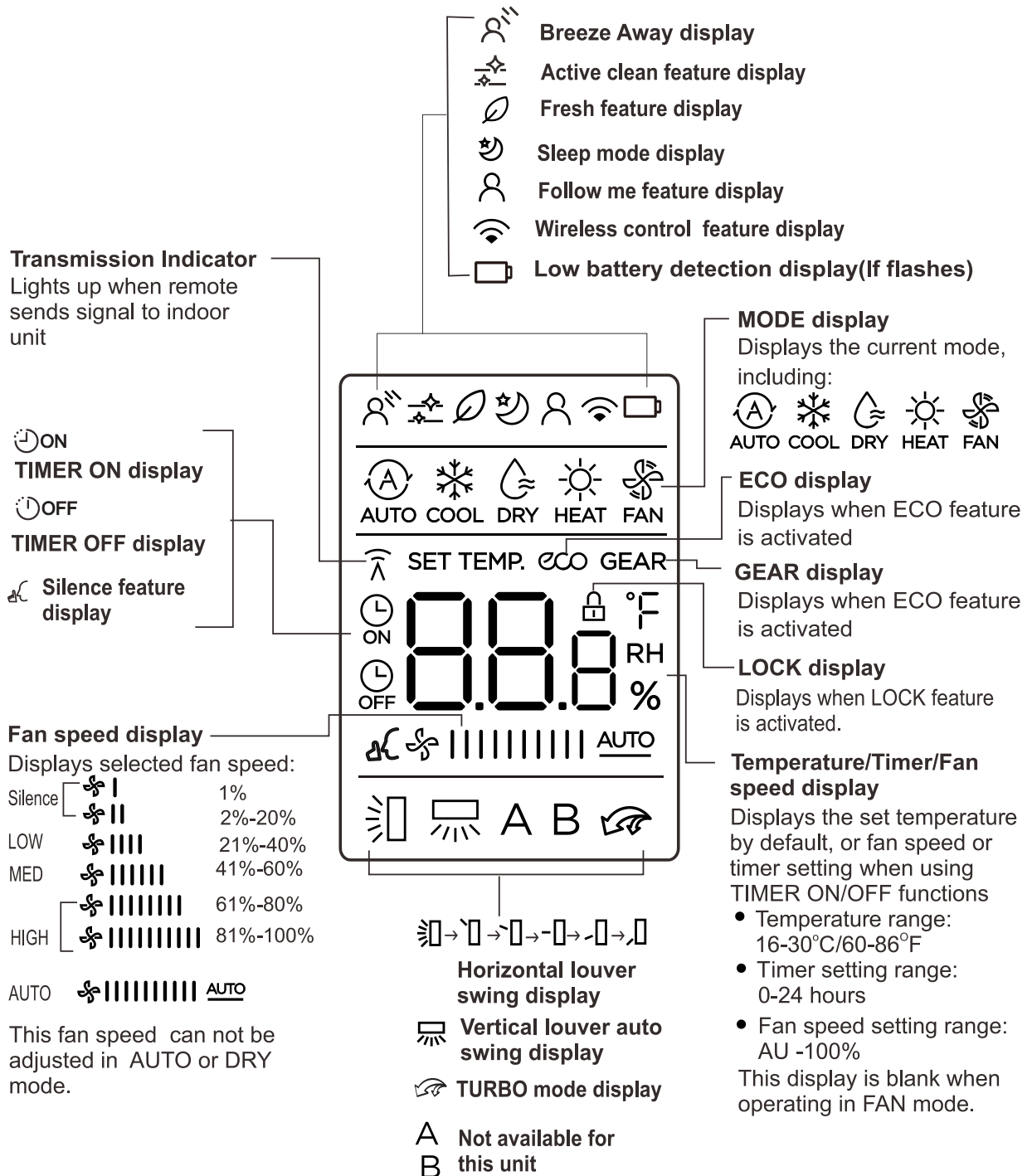

### Note:

All indicators shown in the figure are for the purpose of clear presentation. But during the actual operation, only the relative function signs are shown on the display window.

## 5.1.2 RG10B(B2)/BGEF (Standard for some units)

### Remote Controller Specifications

Model	RG10B(B2)/BGEF
Rated Voltage	3.0V (Dry batteries R03/LR03×2)
Reaching Distance	8m
Environment Temperature Range	-5°C~60°C(23°F~140°F)

### Buttons and Functions

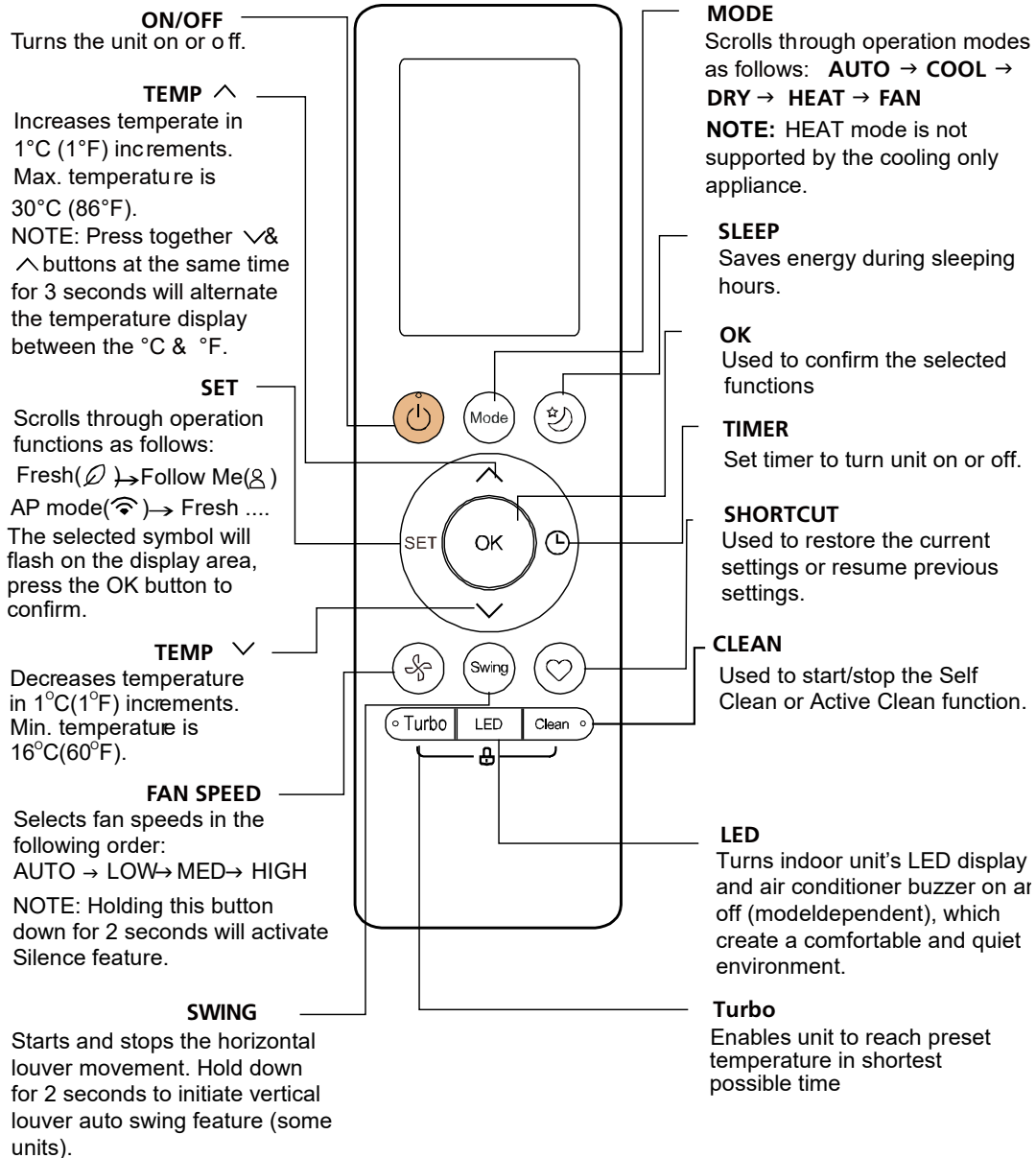



## Remote LCD Screen Indicators

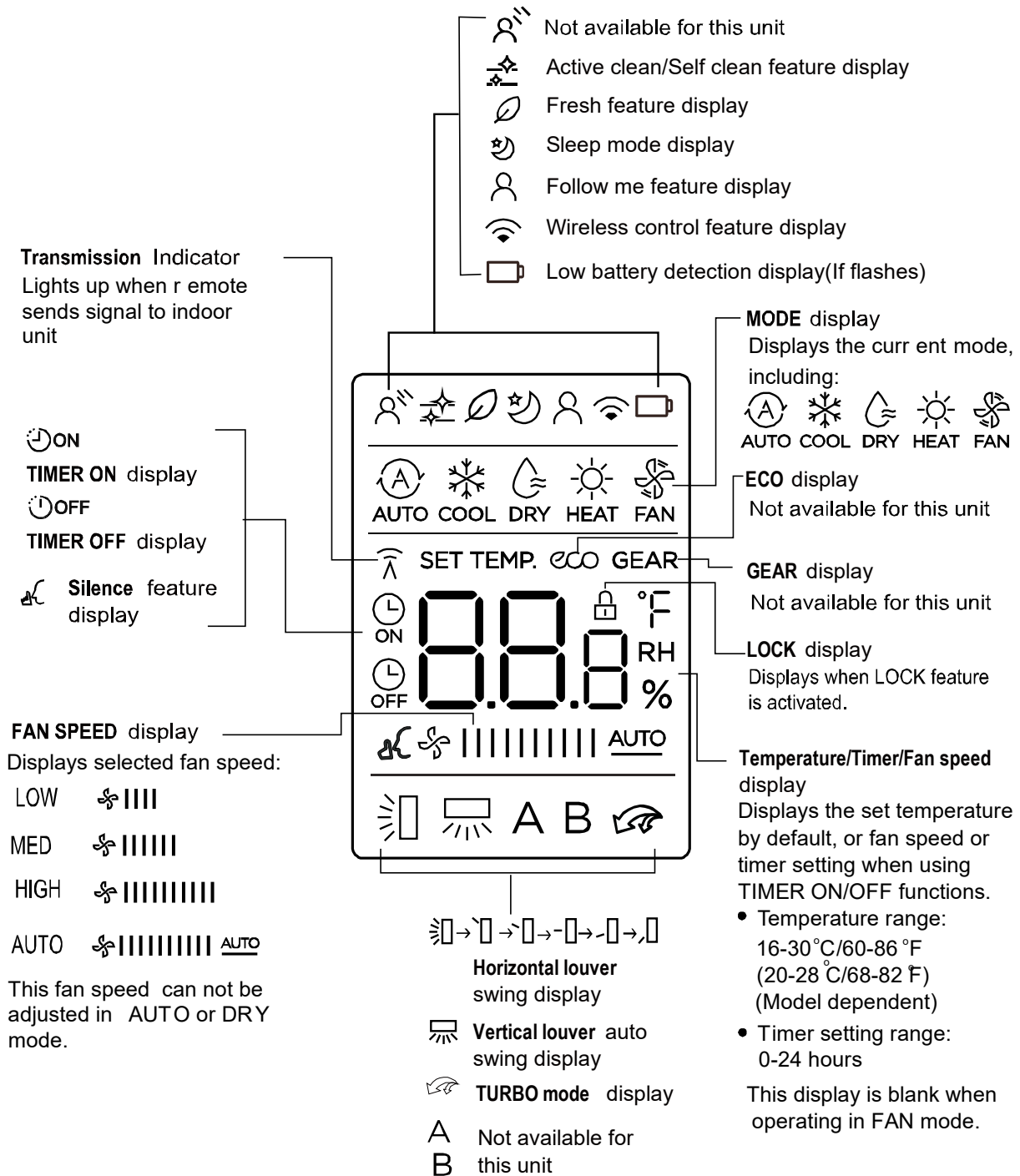

### Note:

All indicators shown in the figure are for the purpose of clear presentation. But during the actual operation, only the relative function signs are shown on the display window.

### 5.1.3 RG10L3(2HS)/BGEFU1 (Standard for some units)

#### Remote Controller Specifications

Model	RG10L3(2HS)/BGEFU1
Rated Voltage	3.0V (Dry batteries R03/LR03×2)
Reaching Distance	8m
Environment Temperature Range	-5°C~60°C(23°F~140°F)

#### Buttons and Functions

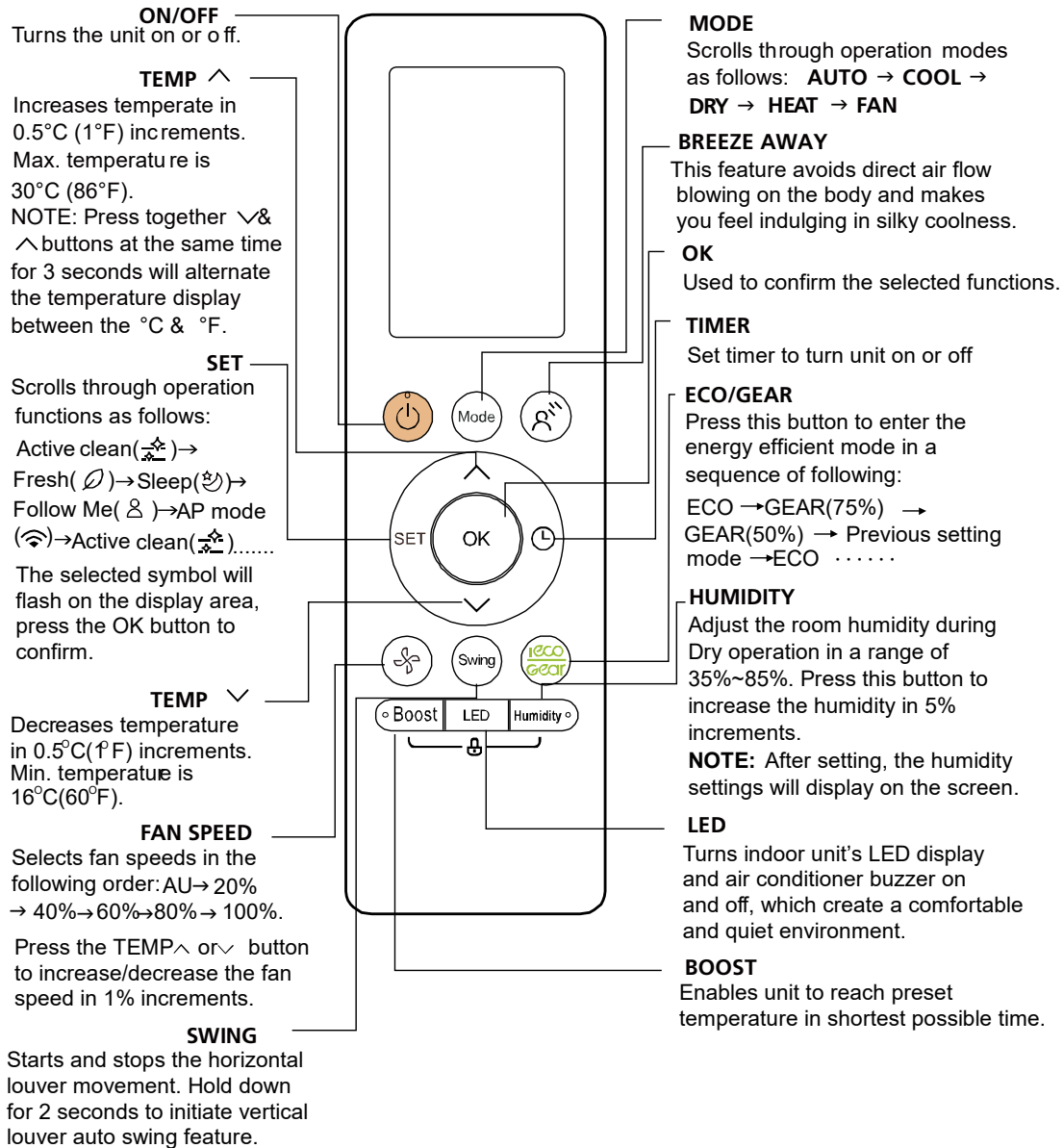

## Remote LCD Screen Indicators

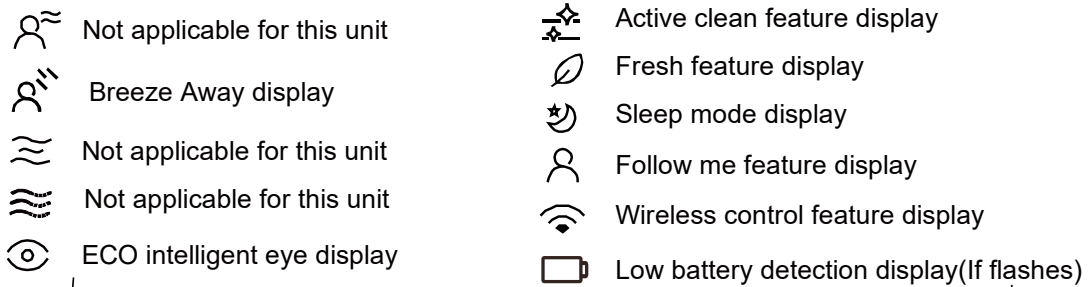

**Transmission Indicator**  
Lights up when remote sends signal to indoor unit

**TIMER ON display**

**TIMER OFF display**

**Silence feature display**

**FAN SPEED display**

Displays selected fan speed:

Silence	1%
LOW	2%-20%
MED	21%-40%
HIGH	41%-60%
	61%-80%
	81%-100%

AUTO

This fan speed can not be adjusted in AUTO or DRY mode.

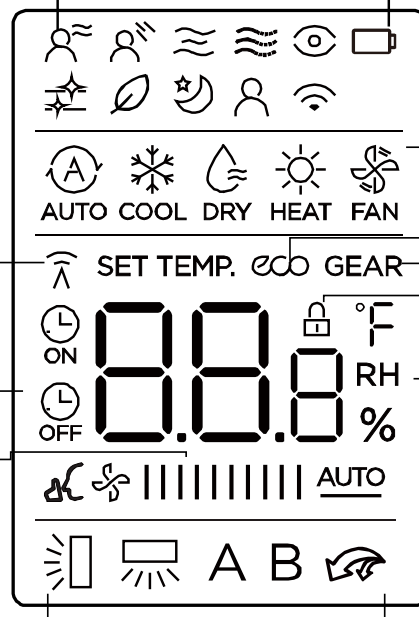

Horizontal louver swing display

Vertical louver auto swing display

TURBO mode display

A Not applicable for this unit  
B Not applicable for this unit

**MODE display**

Displays the current mode, including:

AUTO COOL DRY HEAT FAN

**ECO display**

Displays when ECO feature is activated

**GEAR display**

Displays when GEAR feature is activated

**LOCK display**

Displays when LOCK feature is activated.

**Temperature/Timer/Fan speed display**

Displays the set temperature by default, or fan speed or timer setting when using TIMER ON/OFF functions.

- Temperature range: 16-30°C/60-86°F (20-28°C/68-82°F) (Model dependent)

- Timer setting range: 0-24 hours

- Fan speed setting range: AU -100%

- Humidity setting range: 35% -85%

This display is blank when operating in FAN mode.

## Note:

All indicators shown in the figure are for the purpose of clear presentation. But during the actual operation, only the relative function signs are shown on the display window.

## 5.2 LCD Wired Remote Controller

### 5.2.1 LCD Wired Remote Controller KJR-12B/DP(T)

The KJR-12B/DP(T) wired remote controller is standard for Duct type and is optional for some types.

#### i) Buttons and Functions

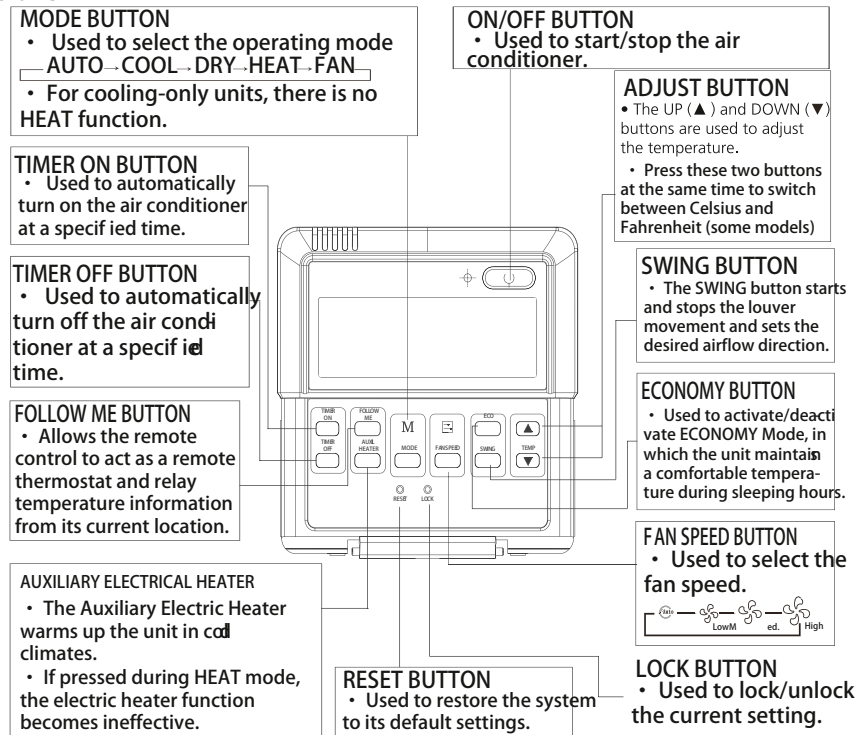

#### ii) LCD Screen

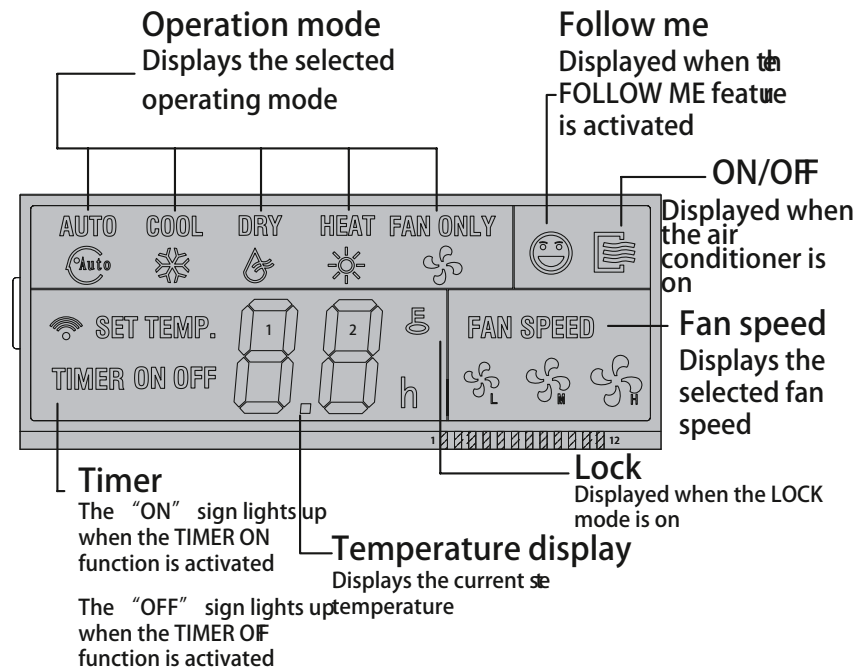

### iii) Installation

- Dimensions

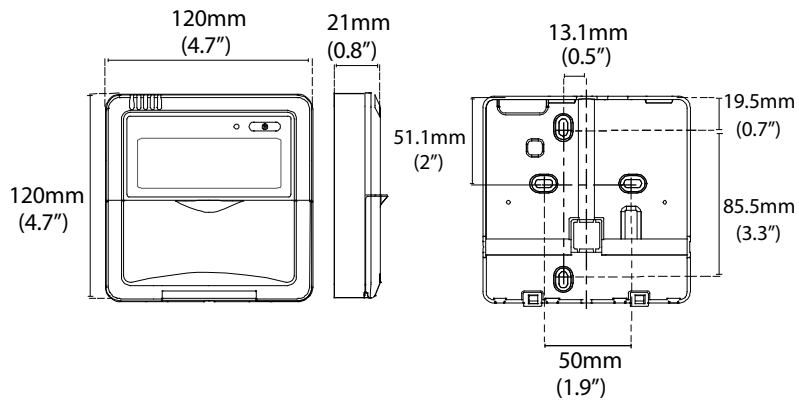

- Wiring diagram

Refer to the following diagram to wire the wall-mounted remote control to the indoor unit.

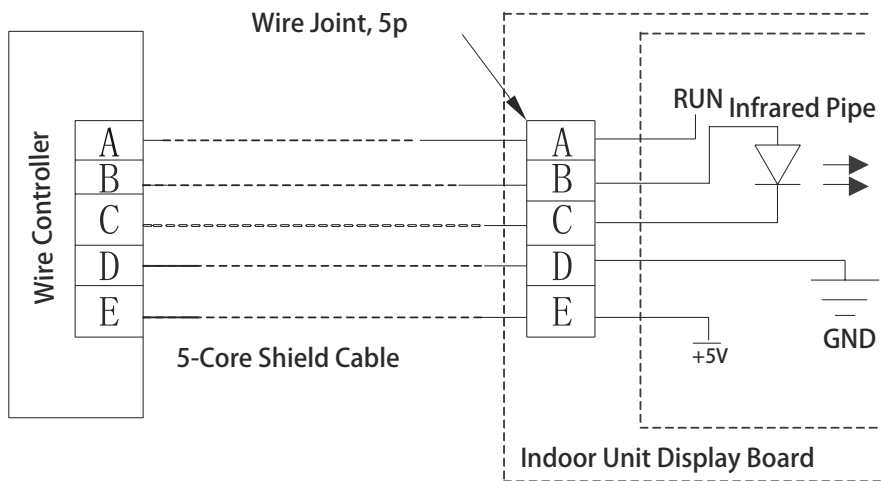

- Installation Diagram

Connect the wire from the display panel of the indoor unit to a connecting cable. Then connect the other side of the connecting cable to the remote control.

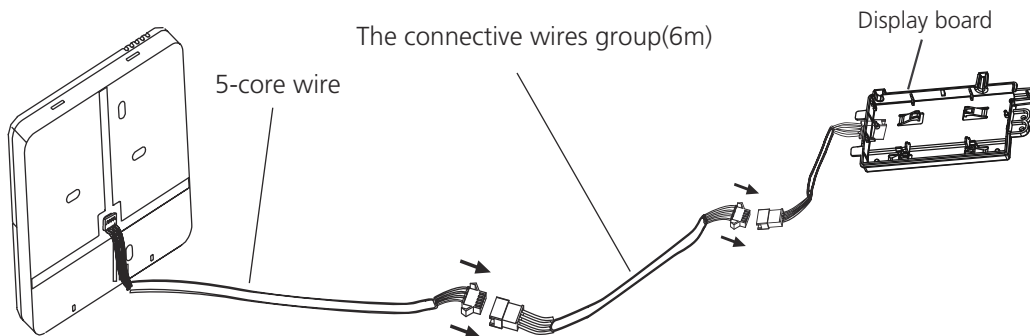

**Note:** Be sure to reserve a length of the connecting wire for periodic maintenance.

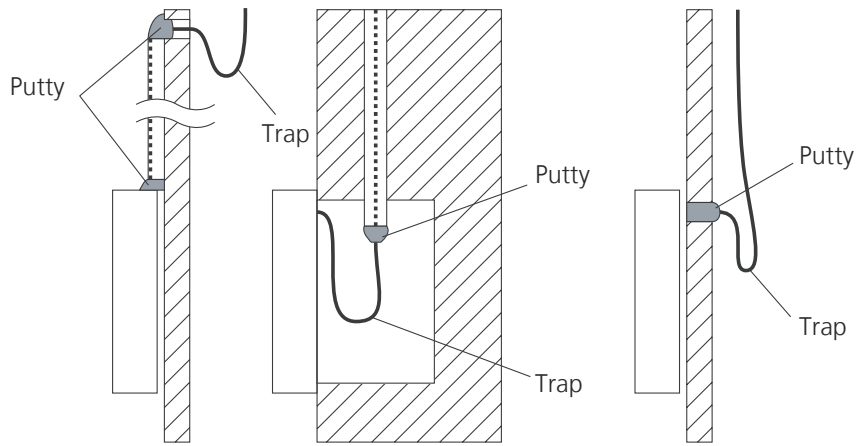

**Note: DO NOT** allow water to enter the remote control. Use the trap and putty to seal the wires.

- For exposed mounting, cut holes on four of the sides according to the picture below.

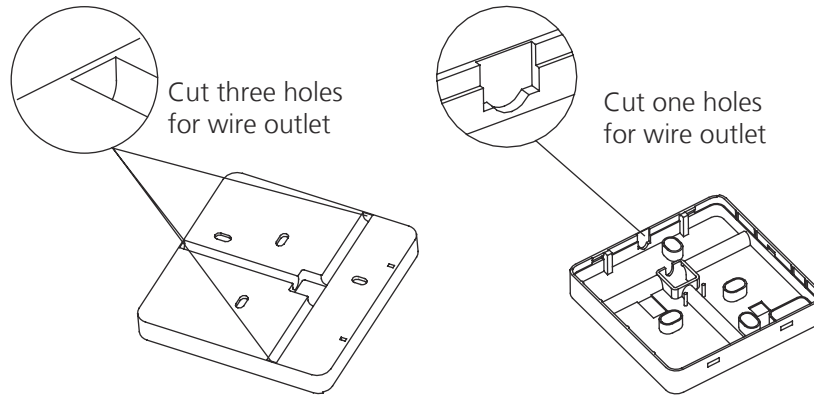

- For shielded wiring, please refer to the picture below.

Embedded switch box wiring

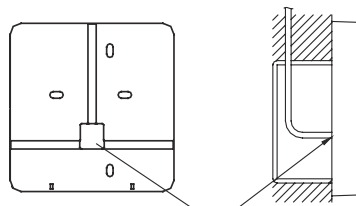

Wiring hole

Wiring through the wall

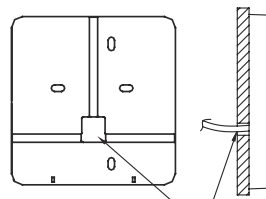

Wall hole and wiring hole  
Diameter of wall hole:  $\Phi$  2cm

## 5.2.2 LCD Wired Remote Controller KJR-120C/TF-E(Optional)

The KJR-120C/TF-E wired remote controller is optional for some types.

### i) Buttons and Functions

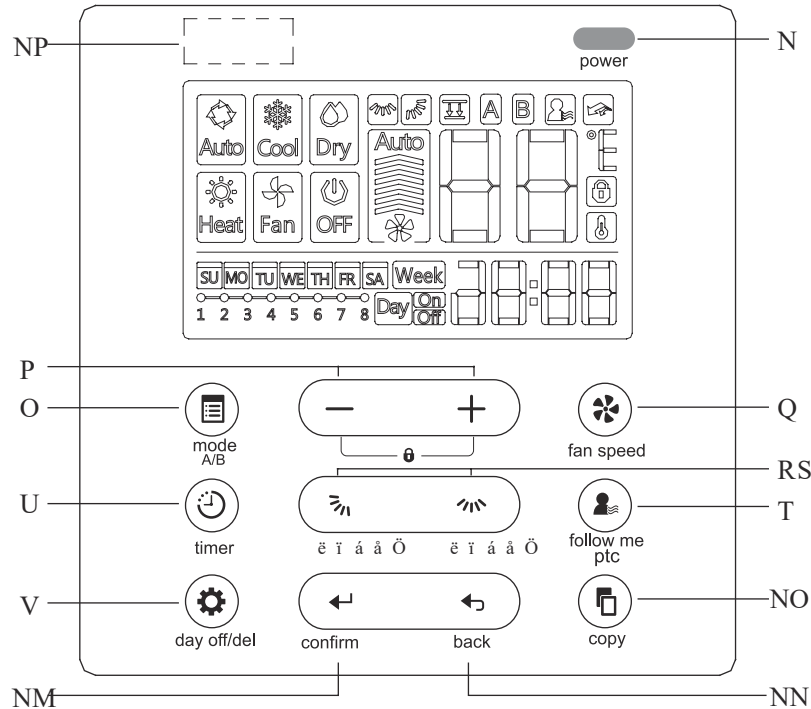

#### 1. POWER button

Turn on or turn off the unit.

#### 2. MODE(A/B) button

Used to select the operation mode: Auto / Cooling / Drying / Heating / Fan;

Hold to activate the operation of auto-lifting panel when off

#### 3. Adjust button

To set temperature, time and timer; set up or down the auto-lifting panel

#### 4. FAN SPEED button

Used to select the fan speed.

#### 5. Up-down airflow direction and swing Button

Press for adjusting the angel of louver, hold for vertical swing; individual louver control for cassette panel

#### 6. Left-right airflow swing Button

Press for stop or start the horizontal swing

#### 7. FOLLOW ME(PTC) button

Allows the remote control to act as a remote thermostat and send temperature information from its current location.

#### 8. TIMER button

To set timer on and timer off time of one day

#### 9. DELAY/DAY OFF button

To set 1 to 2 hours delay off for each day or a whole day off in a weekly timer schedule

#### 10. CONFIRM button

To confirm an setting or call up the menu

#### 11. BACK button

Back to previous operation or superior menu

#### 12. COPY button

Copy timer setting of one day to another in weekly schedule setting

#### 13. Infrared remote receiver (on some models)

## ii) LCD Screen

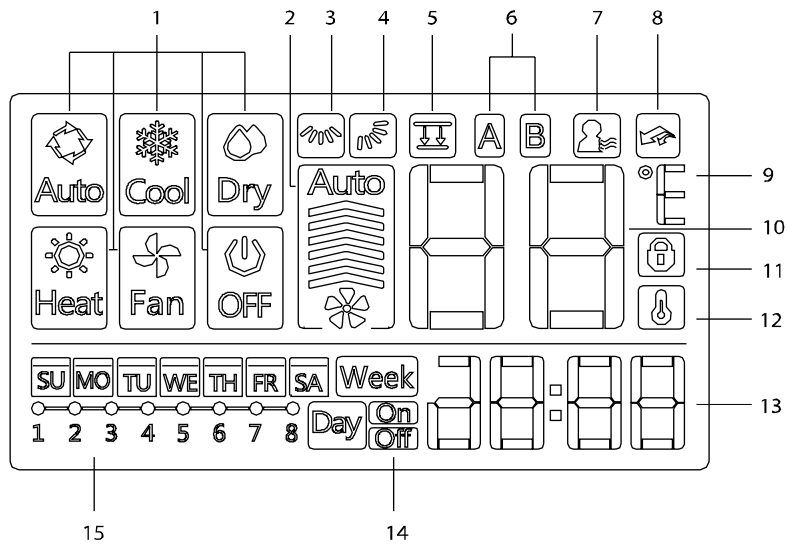

1 Operation mode indication

2 Fan speed indication

3 Left-right swing indication

4 Up-down swing indication

5 Faceplate function indication

6 Main unit and secondary unit indication

7 Follow me function indication

8 PTC function indication

9 C° / F° indication

10 Temperature display

11 Lock indication

12 Room temperature indication

13 Clock display

14 On/Off timer

15 Timer display



### iii) Installation

#### • Dimensions

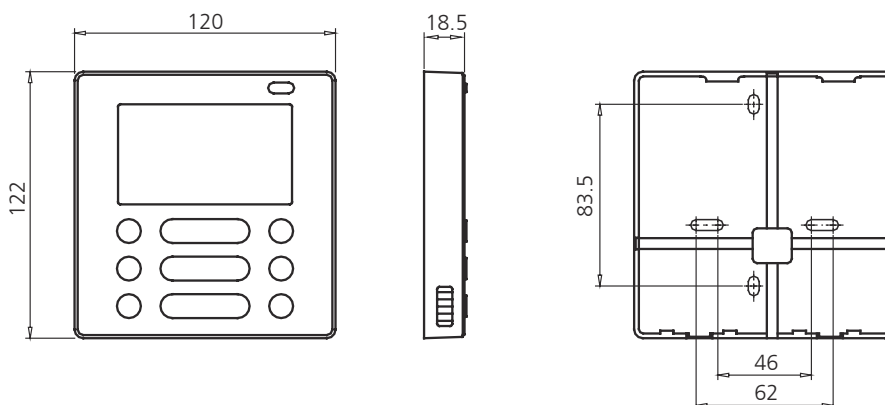

#### • Wiring diagram

Refer to the following diagram to wire the wall-mounted remote control to the indoor unit.

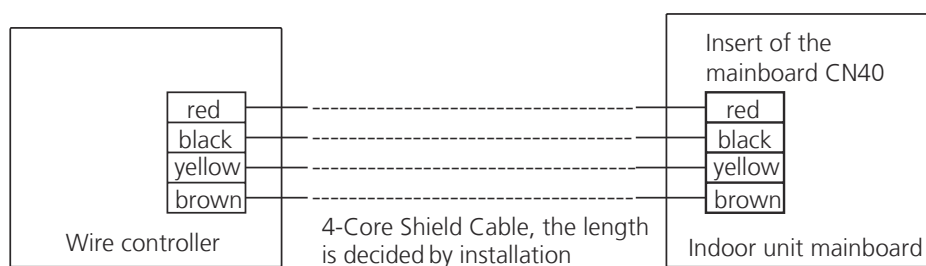

#### • Installation Diagram

Connect the female joint of wires group from the main board with the male joint of connective wires group. Then connect the other side of connective wires group with the male joint of wires group leads from wire controller.

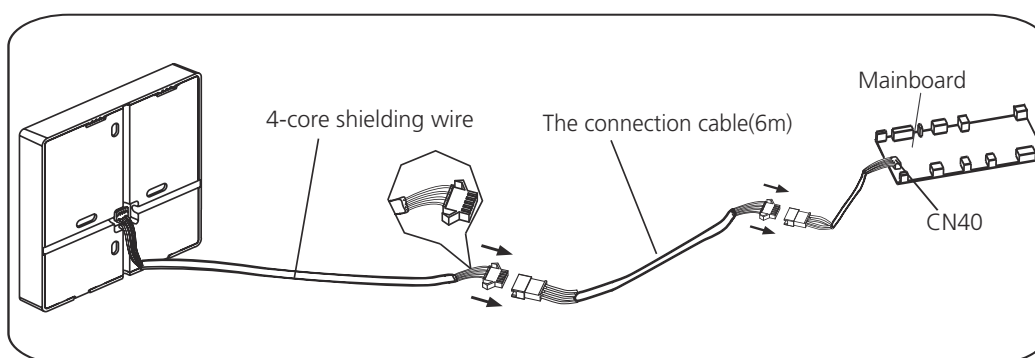

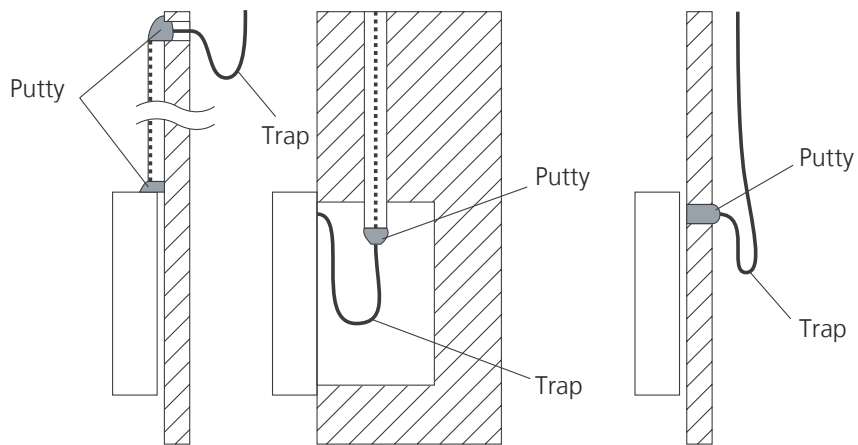

**Note: DO NOT** allow water to enter the remote control. Use the trap and putty to seal the wires.

- For exposed mounting, four outletting positions. There are three need cutting.

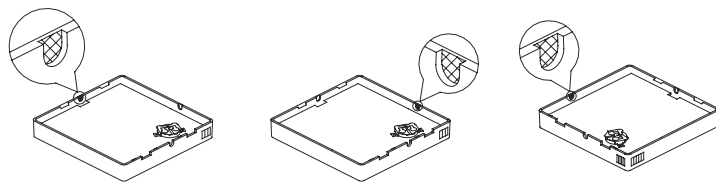

Cutting place of top side wire outlet

Cutting place of left side wire outlet

Cutting place of right side wire outlet

- For shielded wiring, please refer to the picture below.

Embedded switch box wiring

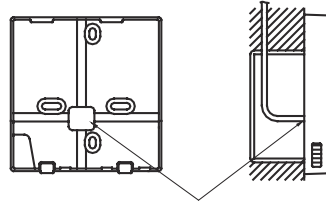

Wiring hole

Wiring through the wall

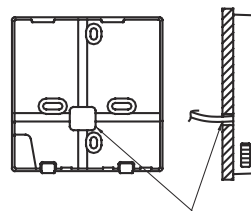

Wall hole and wiring hole  
Diameter of wall hole:  $\Phi 2\text{cm}$

### 5.2.3 LCD Wired Remote Controller KJR-120G/TF-E(Optional)

The KJR-120G/TF-E wired remote controller is optional for some types.

#### i) Buttons and Functions

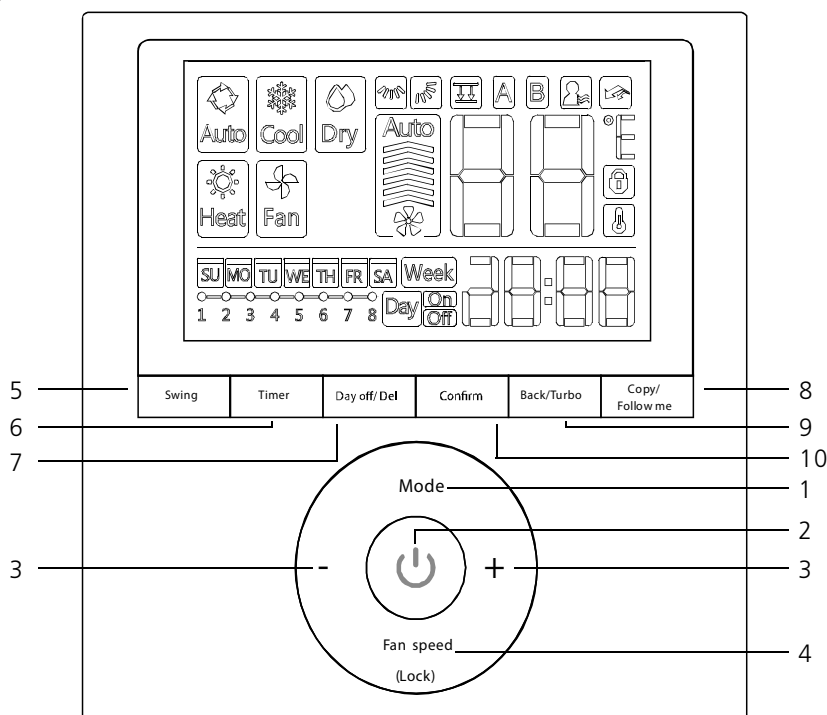

#### 1. MODE button

Used to select the operation mode: Auto / Cooling / Drying / Heating / Fan;

Hold to activate the operation of auto-lifting panel when off

#### 2. POWER button

Turn on or turn off the unit.

#### 3. Adjust button

To set temperature, time and timer; set up or down the auto-lifting panel

#### 4. FAN SPEED button

Used to select the fan speed.

#### 5. Swing Button

Press to active vertical swing, hold for horizontal swing

#### 6. TIMER button

To set timer on and timer off time of one day

#### 7. DELAY/DAY OFF button

To set 1 to 2 hours delay off for each day or a whole day off in a weekly timer schedule

#### 8. COPY/FOLLOW ME button

To copy timer setting of one day to another in weekly schedule setting;

To active the follow me function while in normal operation.

#### 9. BACK/TURBO button

Back to previous operation or superior menu

To active turbo mode while in normal operation

#### 10. CONFIRM button

To confirm an setting or call up the superior menu

ii) LCD Screen

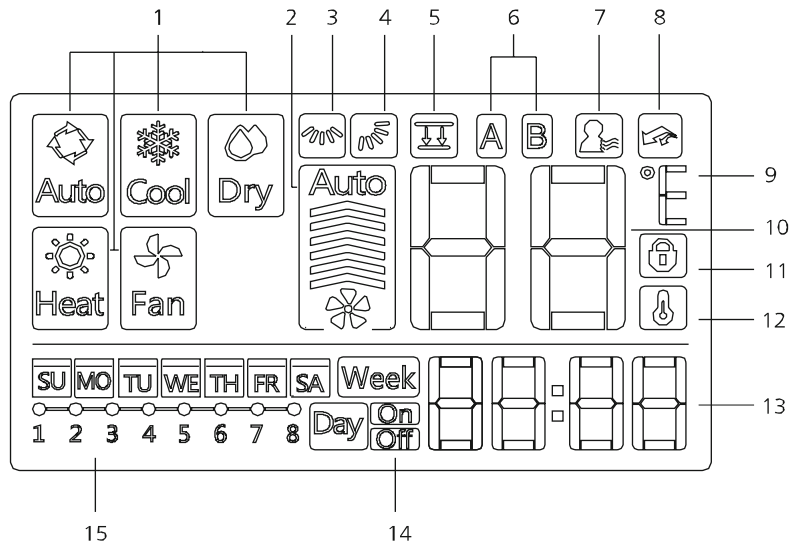

1 Operation mode indication

2 Fan speed indication

3 Left-right swing indication

4 Up-down swing indication

5 Faceplate function indication

6 Main unit and secondary unit indication

7 Follow me function indication

8 Turbo/PTC function indication

9 C° / F° indication

10 Temperature display

11 Lock indication

12 Room temperature indication

13 Clock display

14 On/Off timer

15 Timer display

### iii) Installation

- Dimensions

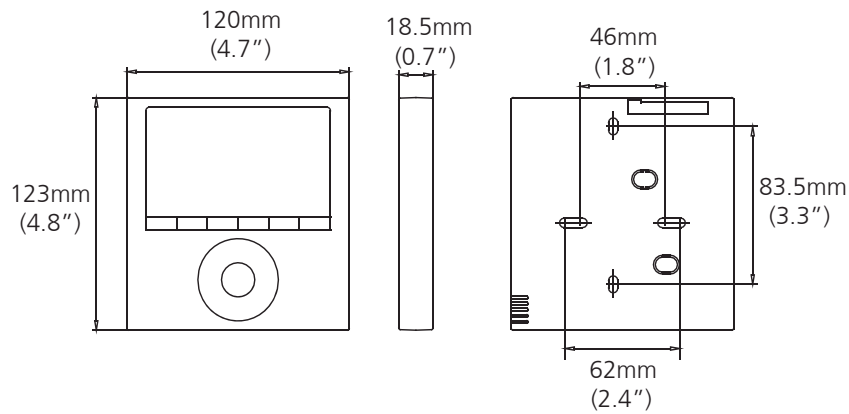

- Wiring diagram

1) Connection

For Cassette: The wired controller connects to main control board directly.

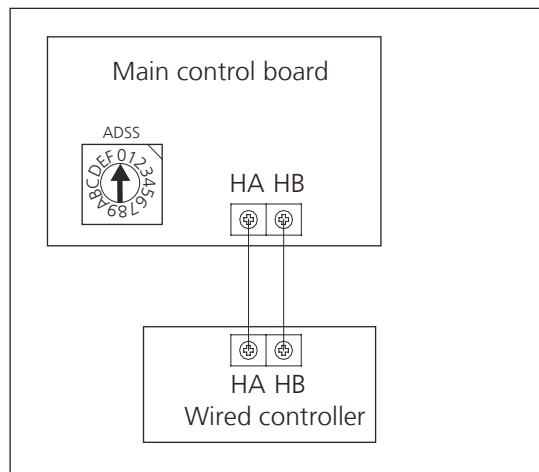

For Duct, Ceiling & floor: The wired controller connects to terminal board, terminal board connects to main control board.

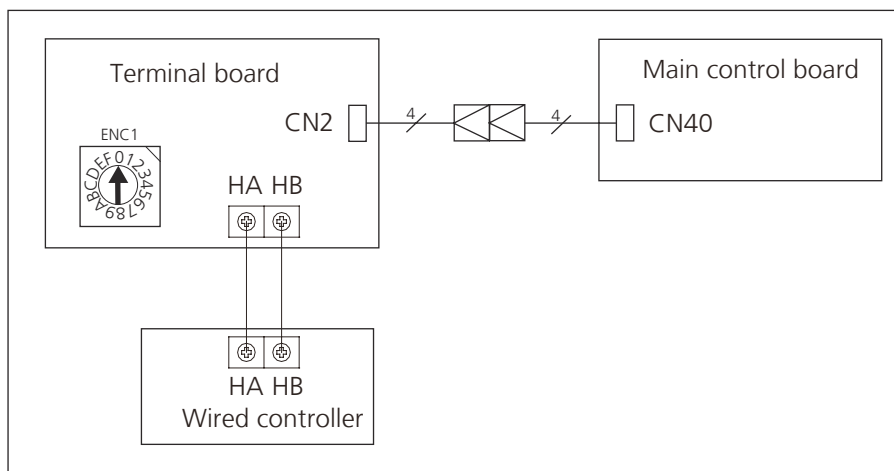

---

## 2) Address setting

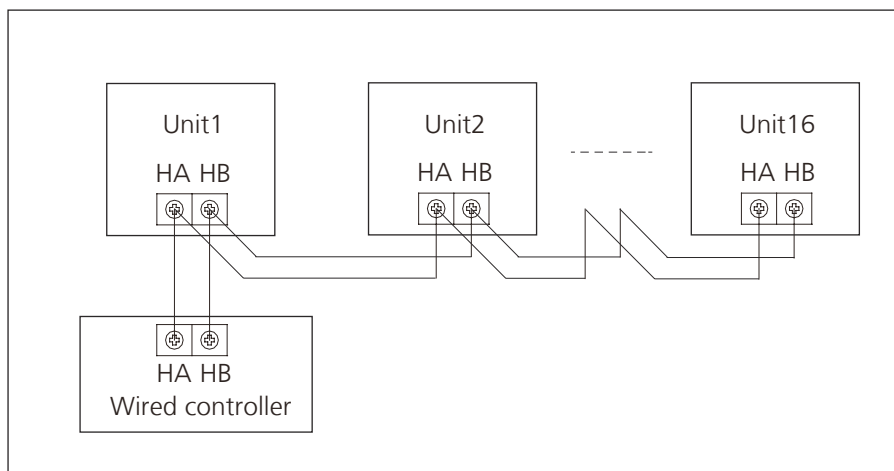

- One non-polarity controller can control up to 16 indoor units.
- When the non-polarity controller is connected to several units, every air-conditioner in network has only one network address to distinguish each other.
- Address code of air-conditioner in LAN is set by code switch ENC1(Duct and Ceiling& Floor) or ADSS(Cassette) of the indoor unit, and the set range is 0-15.
- Note: The indoor units are controlled at the same time, not independently. The purpose of setting network address is identify the unit when error occurs.

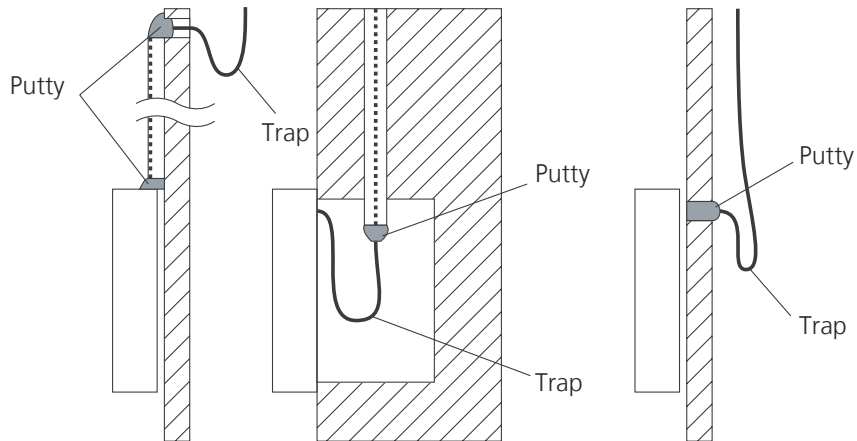

**Note: DO NOT** allow water to enter the remote control. Use the trap and putty to seal the wires.

• **For wiring the indoor unit, there are four methods:**

- From the rear;
- From the bottom;
- From the top;
- From the top center.

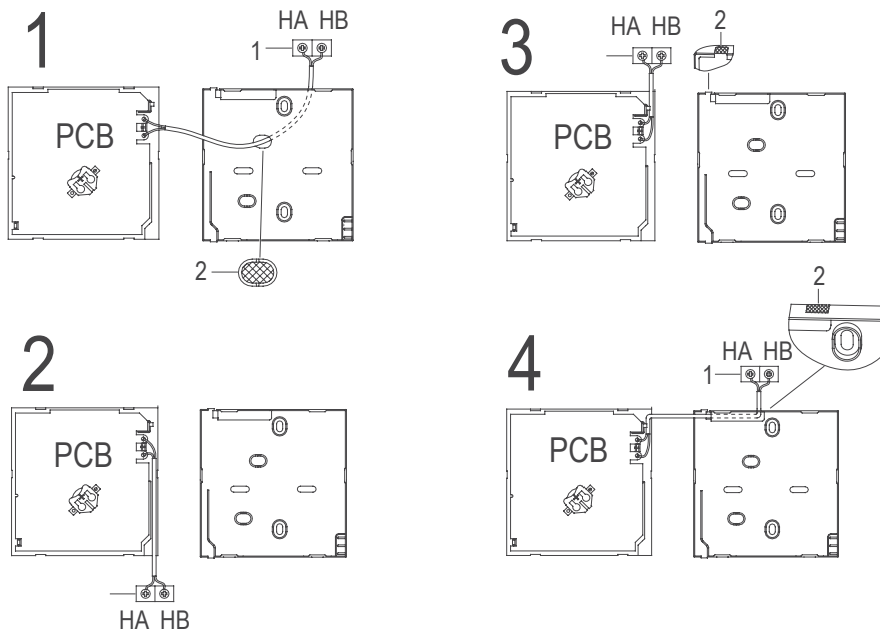

- 1: Indoor Unit.
- 2: Notch the part for the wiring to pass through with a nipper tool.
- Connect the terminals on the remote controller (HA ,HB), and the terminals of the indoor unit. (HA ,HB). (HA and HB do not have polarity.)

## 5.2.4 LCD Wired Remote Controller KJR-120X/TFBG-E(Optional)

The KJR-120X/TFBG-E wired remote controller is optional for some types.

### i) Buttons and Functions

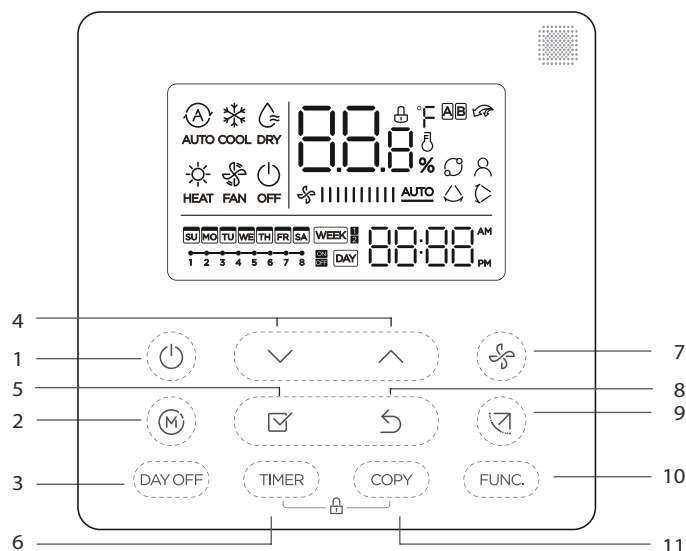

#### 1. POWER button

Turn on or turn off the unit.

#### 2 MODE button

Used to select the operation mode: Auto / Cooling / Drying / Heating / Fan;

#### 3. DAY OFF/DEL button

To set 1 to 2 hours delay off for each day or a whole day off in a weekly timer schedule.

#### 4. Adjust button

To set temperature, time and timer

#### 5. CONFIRM button

To confirm an setting or call up the superior menu

#### 6. TIMER button

To set timer on and timer off time of one day

#### 7. FAN SPEED button

Used to select the fan speed.

#### 8. BACK button

Back to previous operation or superior menu

#### 9. Swing Button

Press to active vertical swing, hold for horizontal swing

#### 10. FUNC. button

Press the FUNC. button to set the turbo or rotating or I feel function.

#### 11. COPY button

To copy timer setting of one day to another in weekly schedule setting.



## ii) LCD Screen

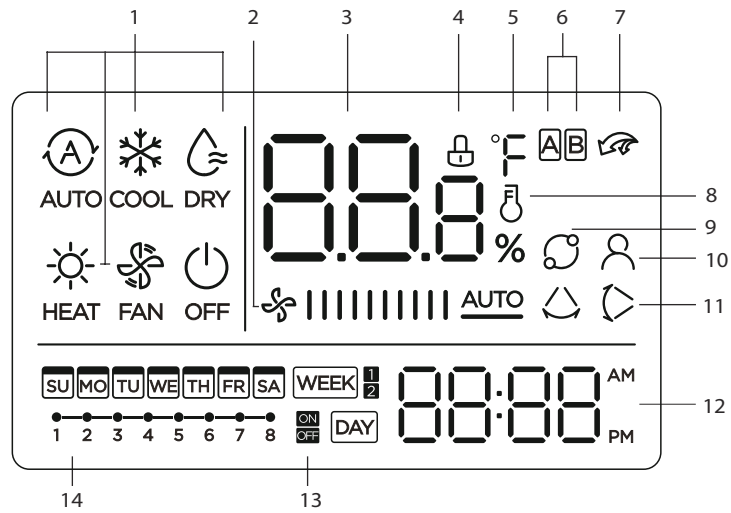

- |  |   |
|--|---|
| 1 Operation mode indication                  | 8 Room temperature indication                   |
| 2 Fan speed indication                       | 9 Rotating indication                           |
| 3 Temperature display                        | 10 Follow Me function indication                |
| 4 Lock indication                            | 11 Left-right swing indication<br>(some models) |
| 5 °C / °F indication                         | 12 Clock display                                |
| 6 Main unit and secondary unit<br>indication | 13 On/Of timer                                  |
| 7 Turbo function indication                  | 14 Timer display                                |

### iii) Installation

#### • Dimensions

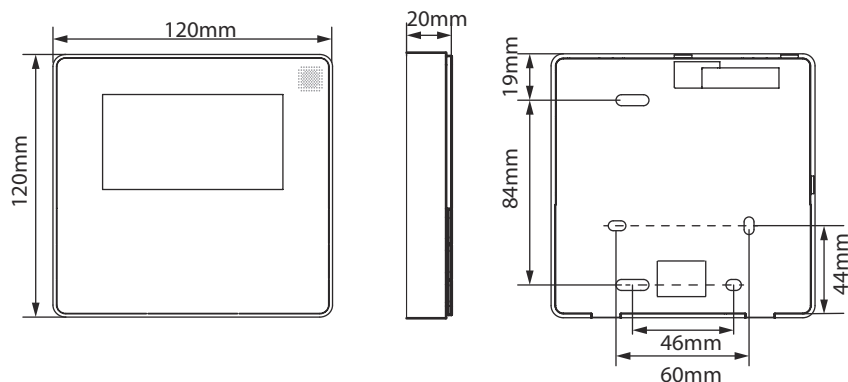

### 3) Connection

#### • Wire with the indoor unit:

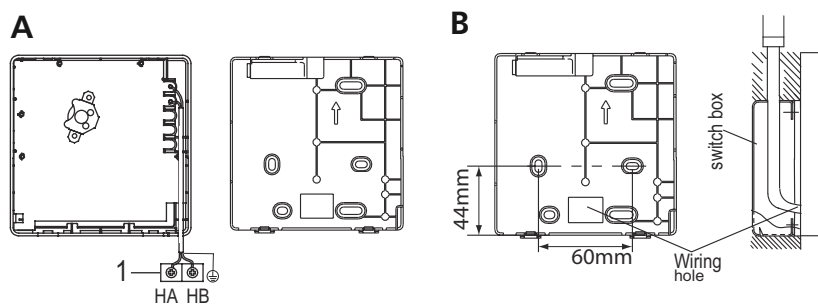

- 1: Indoor Unit.
- 2: Notch the part for the wiring to pass through with a nipper tool.
- Connect the terminals on the remote controller (HA ,HB), and the terminals of the indoor unit. (HA ,HB). (HA and HB do not have polarity.)

For some models: The wired controller connects to main control board directly.

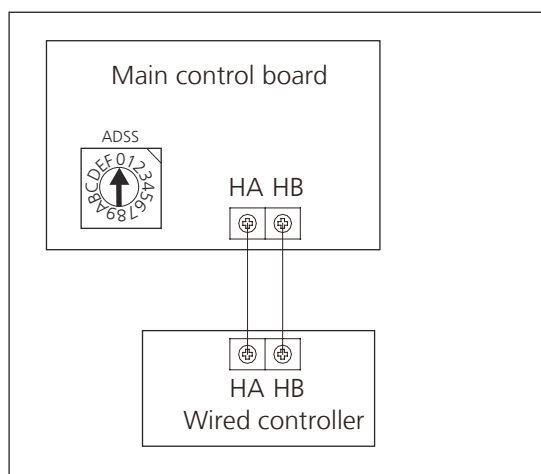

For some models: The wired controller connects to terminal board, terminal board connects to main control board.

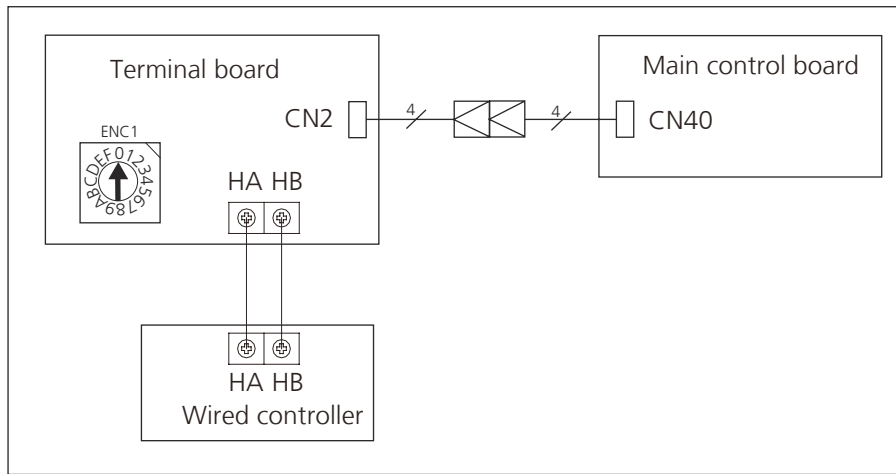

#### 4) Address setting

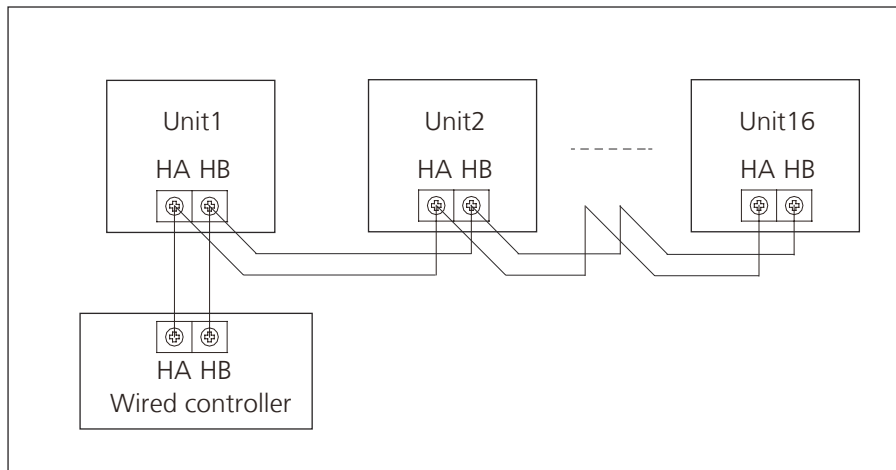

- One non-polarity controller can control up to 16 indoor units.
- When the non-polarity controller is connected to several units, every air-conditioner in network has only one network address to distinguish each other.
- Address code of air-conditioner in LAN is set by code switch ENC1(Duct and Ceiling& Floor) or ADSS(Cassette) of the indoor unit, and the set range is 0-15.
- Note: The indoor units are controlled at the same time, not independently. The purpose of setting network address is identify the unit when error occurs.

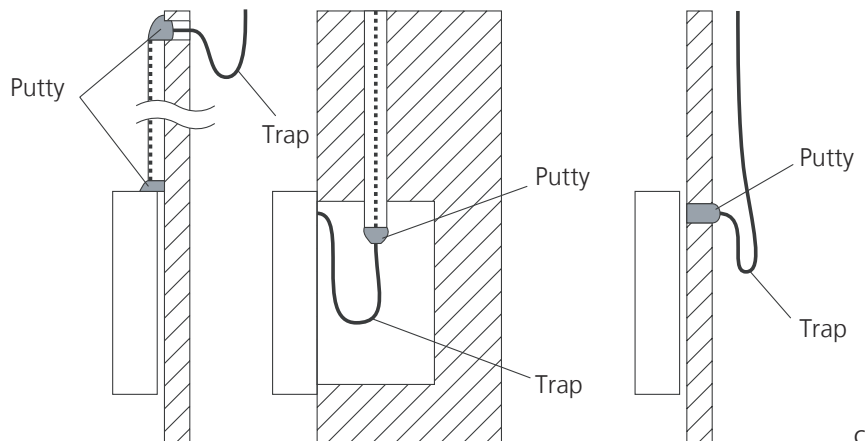

**Note: DO NOT** allow water to enter the remote control. Use the trap and putty to seal the wires.

## 5.3 Centralized Controller

### 1) Connection

For Light commercial air conditioner with XYE port, it can be directly connected to Centralized Controller (CCM03, CCM09).

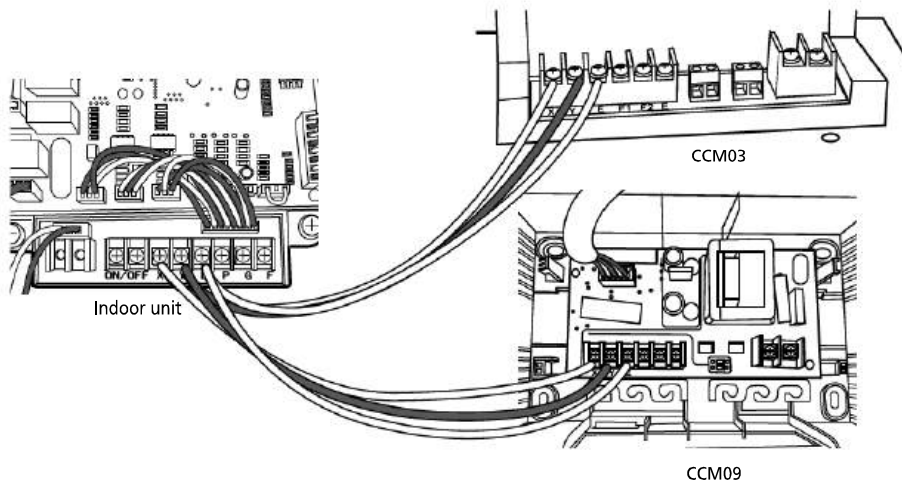

### 2) Address setting

When setting the address, please make sure the unit is powered off. The address can be set from 0 to 63 by the switch. Turn on the unit, then the address will be effective.

SWITCH		FOR CCM UNIT ADDRESS	
S2 + S1			
ADDRESS	0~15		16~31
Factory Setting	✓		
S2 + S1			
ADDRESS	32~47		48~63
Factory Setting			

Note: For light commercial air conditioner with XYE port, it can be also connected to BMS (Building Management System).

If there is any CAC (central air conditioner) connecting with the central controller at the same time, please set the address from largest (63,62,61...), since the CAC units could obtain address automatically from the smallest (00,01,02...)

---

# Troubleshooting

## Contents

<b>1.</b>	<b>Safety Caution .....</b>	<b>3</b>
<b>2.</b>	<b>General Troubleshooting .....</b>	<b>4</b>
<b>3.</b>	<b>Information Inquiry .....</b>	<b>6</b>
<b>4.</b>	<b>Error Diagnosis and Troubleshooting Without Error Code.....</b>	<b>9</b>
	4.1 Remote maintenance.....	9
	4.2 Field maintenance .....	10
<b>5.</b>	<b>Quick Maintenance by Error Code.....</b>	<b>15</b>
<b>6.</b>	<b>Troubleshooting by Error Code.....</b>	<b>16</b>
	6.1 EH 00/EH 0A / EC 51 (EEPROM parameter error Diagnosis and Solution).....	16
	6.2 EL 01 (Indoor and outdoor unit communication error Diagnosis and Solution)	17
	6.3 EH 03 / EH 31/EH 32/EC 07 (Fan speed is operating outside of the normal range Diagnosis and Solution) .....	19
	6.4 EH 60/EH 61/EC 53/EC 52/EC 54 (Open circuit or short circuit of temperature sensor diagnosis and solution) .....	22
	6.5 EL 0C (Refrigerant Leakage Detection Diagnosis and Solution) .....	23
	6.6 EH 0E (Water-Level Alarm Malfunction Diagnosis and Solution).....	24
	6.7 PC 00 (IPM Malfunction or IGBT Over-strong Current Protection Diagnosis and Solution).....	25
	6.8 PC 01 (Over Voltage or Too Low Voltage Protection Diagnosis and Solution)	26

# Troubleshooting

## Contents

6.9	PC 04 (Inverter Compressor Drive Error Diagnosis and Solution).....	27
6.10	PC 03 (High Pressure Protection or low Pressure Protection Diagnosis and Solution).....	28
6.11	PC 02 (Top temperature protection of compressor or High temperature protection of IPM module Diagnosis and Solution).....	31
6.12	PC 0L (Low ambient temperature protection).....	32
6.13	EC 0d (Outdoor unit malfunction Diagnosis and Solution).....	32
6.14	EH 0b (Communication error between display board and main board Diagnosis and Solution).....	33
6.15	EH b3 (Communication error between wired controller and indoor unit Diagnosis and Solution) .....	34
6.16	EH bA(Communication malfunction between external fan module and indoor unit)/EH 3A(External fan DC bus voltage is too low protection)/ EH 3b(External fan DC bus voltage is too high fault) diagnosis and solution .....	35
6.17	FH 07(Communication malfunction between indoor unit and auto-lifting panel) diagnosis and solution .....	36
<b>7.</b>	<b>Check Procedures .....</b>	<b>37</b>

## 1. Safety Caution

### ⚠ WARNING

Be sure to turn off all power supplies or disconnect all wires to avoid electric shock. While checking indoor/outdoor PCB, please equip oneself with antistatic gloves or wrist strap to avoid damage to the board.

### ⚠ WARNING

Electricity remains in capacitors even when the power supply is off. Ensure the capacitors are fully discharged before troubleshooting.

Test the voltage between P and N on back of the main PCB with multimeter. If the voltage is lower than 36V, the capacitors are fully discharged. For models that cannot be measured, wait 5 minutes after the power supply is off to ensure that the capacitors are fully discharged.

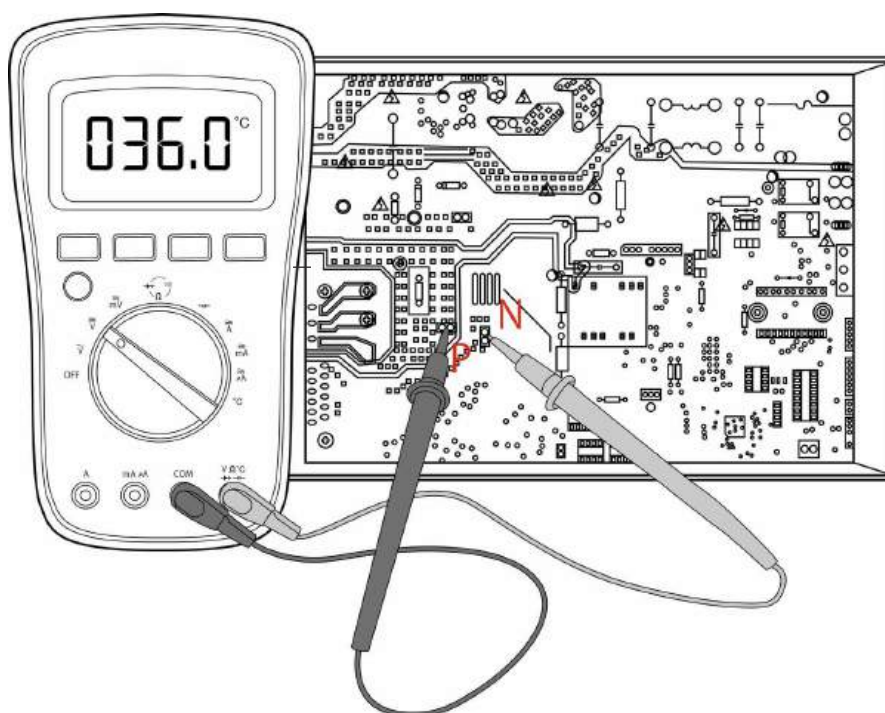

**Note:** This picture is for reference only. Actual appearance may vary.

## 2. General Troubleshooting

### 2.1 Error Display (Indoor Unit)

When the indoor unit encounters a recognized error, the operation lamp will flash in a corresponding series, the timer lamp may turn on or begin flashing, and an error code will be displayed. These error codes are described in the following table:

Operation Lamp	Timer Lamp	Display	Error Information	Solution
1 time	OFF	E400/ E40A	Indoor unit EEPROM parameter error	TS16
2 times	OFF	E401	Indoor / outdoor unit communication error	TS17
4 times	OFF	E403	The indoor fan speed is operating outside of the normal range(for some models)	TS19
4 times	OFF	E431	Upper indoor fan speed is operating outside of the normal range(for new console type)	TS19
4 times	OFF	E432	Lower indoor fan speed is operating outside of the normal range(for new console type)	TS19
6 times	OFF	E460	Indoor room temperature sensor T1 is in open circuit or has short circuited	TS22
6 times	OFF	E461	Evaporator coil temperature sensor T2 is in open circuit or has short circuited	TS22
8 times	OFF	E40C	Refrigerant leakage detection	TS23
9 times	OFF	E40B	Communication error between display board and main board	TS33
13 times	OFF	E40E	Water-level alarm malfunction	TS24
5 times	OFF	E453	Outdoor room temperature sensor T4 is in open circuit or has short circuited	TS22
5 times	OFF	E452	Condenser coil temperature sensor T3 is in open circuit or has short circuited	TS22
5 times	OFF	E454	Compressor discharge temperature sensor TP is in open circuit or has short circuited	TS22
5 times	OFF	E455	IGBT temperature sensor TH is in open circuit or has short circuited	TS22
5 times	OFF	E456	Evaporator coil outlet temperature sensor T2B is in open circuit or has short circuited(for free-match indoor units)	TS22
5 times	ON	E451	Outdoor unit EEPROM parameter error	TS16
12 times	OFF	E407	The outdoor fan speed is operating outside of the normal range(for some models)	TS19



7 times	FLASH	PC00	IPM malfunction or IGBT over-strong current protection	TS25
2 times	FLASH	PC01	Over voltage or over low voltage protection	TS26
3 times	FLASH	PC02	Top temperature protection of compressor or High temperature protection of IPM module	TS31
5 times	FLASH	PC04	Inverter compressor drive error	TS27
7 times	FLASH	PC03	High pressure protection or low pressure protection (for some models)	TS28
14 times	OFF	EC0d	Outdoor unit malfunction(for some models)	TS32
15 times	OFF	FH07	Communication malfunction between indoor unit and auto-lifting panel	TS36
--	--	EHbA	Communication malfunction between external fan module and indoor unit(for some models)	TS35
4 times	OFF	EH3A	External fan DC bus voltage is too low protection(for some models)	TS35
4 times	OFF	EH3b	External fan DC bus voltage is too high fault(for some models)	TS35
1 time	ON	--	Indoor units mode conflict(match with multi outdoor unit)	--
4 times	FLASH	PC0L	Low ambient temperature protection(for some models)	TS32

#### For other errors:

The display board may show a garbled code or a code undefined by the service manual. Ensure that this code is not a temperature reading.

#### Troubleshooting:

Test the unit using the remote control. If the unit does not respond to the remote, the indoor PCB requires replacement. If the unit responds, the display board requires replacement.

#### LED flash frequency:

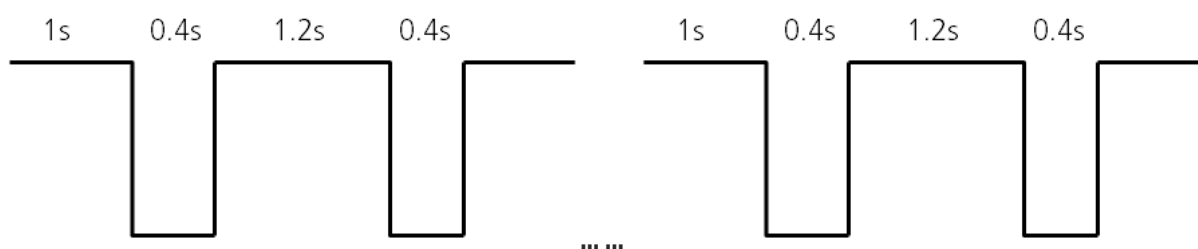

## 2.2 Error Display on Two Way Communication Wired Controller

Display	Malfunction or Protection	Solution
EHb3	Communication error between wire controller and indoor unit((for KJR-120X series wired controller)	TS34

The other error codes displayed on the wire controller are same from those on the unit.

### 3. Information Inquiry

- To enter engineer mode, in power-on or standby mode, and in non-locked state, press the key combination "ON/OFF + Air Speed" for 7s:
- After entering the engineer mode, the remote control will display icons of "Auto, Cool, Dry, Heat", and the Battery icon; at the same time, it will also display the numeric code of the current engineer mode (for the initial engineer mode, the numeric code displayed is 0), and all other icons are inactive.
- In engineer mode, the value of the current numeric code can be adjusted circularly through the Up/Down key, with the setting range of 0 to 30.

Code	Query Content	Additional Notes
0	Error code	Refer to next list of error code
1	Room temperature	T1 temperature
2	Indoor coil temperature	T2 temperature
3	Outdoor coil temperature	T3 temperature
4	Ambient temperature	T4 temperature
5	Discharge temperature	TP temperature
6	Compressor Target Frequency FT	Targeted Frequency
7	Compressor Running Frequency Fr	Actual Frequency
8	Unit Current dL	N/A
9	Outdoor AC Voltage Uo	N/A
10	Current indoor capacity test state Sn	N/A
11	Running mode od	
12	Set Speed Pr of the outdoor fan	Outdoor fan speed=value*8
13	Opening Lr of EEV	EXV opening angle=value*8
14	Actual Running Speed ir of the indoor fan	Indoor fan speed=value*8
15	Indoor Humidity Hu	N/A
16	Set Temperature TT after compensation	N/A
17		N/A
18		N/A
19	/	N/A
20	Indoor Target Frequency oT	N/A
21	Reserve	
22		
23		
24		
25		
26		
27		
28		
29		
30		

Exit of engineer mode:

1)In engineer mode, press the key combination of "On/Off + Air speed" for 2s;

2)The engineer mode will be exited if there are no valid key operations for continuous 60s.

error code of engineer mode

Display	Error Information
EH00/EH0A	Indoor unit EEPROM parameter error
EL01	Indoor / outdoor unit communication error
EH1A	Communication error between indoor unit and indoor external fan module
EH30	Parameters error of indoor external fan
EH31	Upper indoor fan speed is operating outside of the normal range(for new console type)
EH32	Lower indoor fan speed is operating outside of the normal range(for new console type)
EH35	Phase failure of indoor external fan
EH36	Indoor external fan current sampling bias fault
EH37	Indoor external fan zero speed failure
EH38	Indoor external fan stall failure
EH39	Out of step failure of indoor external fan
EH3A	Low voltage protection of indoor external fan DC bus
EH3B	Indoor external fan DC bus voltage is too high fault
EH3E	Indoor external fan overcurrent fault
EH3F	Indoor external fan module protection/hardware overcurrent protection
EH03	The indoor fan speed is operating outside of the normal range
EC51	Outdoor unit EEPROM parameter error
EC52	Condenser coil temperature sensor T3 is in open circuit or has short circuited
EC53	Outdoor room temperature sensor T4 is in open circuit or has short circuited
EC54	Compressor discharge temperature sensor TP is in open circuit or has short circuited
EC55	IGBT temperature sensor TH is in open circuit or has short circuited
EC0d	Outdoor unit malfunction
EH60	Indoor room temperature sensor T1 is in open circuit or has short circuited
EH61	Evaporator coil temperature sensor T2 is in open circuit or has short circuited
EC71	Outdoor external fan overcurrent fault
EC75	Outdoor external fan module protection/hardware overcurrent protection
EC72	Outdoor external fan phase failure
EC74	Outdoor external fan current sampling bias fault
EC73	Zero speed failure of outdoor unit DC fan
EC07	The outdoor fan speed is operating outside of the normal range(
EHb5	Intelligent eye communication failure
EL0C	Refrigerant leak detected
EH0b	Communication error between indoor two chips
EH0b	Communication error between display board and main board(for new console type)
EH0E	Water-level alarm malfunction
EH0F	Intelligent eye malfunction
FH07	Communication malfunction between indoor unit and auto-lifting panel

PC 00	IPM malfunction or IGBT over-strong current protection
PC 10	Over low voltage protection
PC 11	Over voltage protection
PC 12	DC voltage protection
PC 02	Top temperature protection of compressor or High temperature protection of IPM module
PC 40	Communication error between outdoor main chip and compressor driven chip
PC 41	Current Input detection protection
PC 42	Compressor start error
PC 43	Lack of phase (3 phase) protection
PC 44	Outdoor unit zero speed protection
PC 45	341PWM error
PC 46	Compressor speed malfunction
PC 49	Compressor over current protection
PC 06	Compressor discharge temperature protection
PC 08	Outdoor current protection
PH 09	Anti-cold air in heating mode
PC 0F	PFC module malfunction
PC 30	System overpressure protection
PC 31	System pressure is too low protection
PC 03	Pressure protection
PC 0L	Outdoor low ambient temperature protection
PH 90	Evaporator coil temperature over high protection
PH 91	Evaporator coil temperature over low Protection
PC 0R	Condenser high temperature protection
PH 0C	Indoor unit humidity sensor failure
LH 00	Frequency limit caused by T2
LH 30	Indoor external fan current limit
LH 31	Indoor external fan voltage limit
LC 01	Frequency limit caused by T3
LC 02	Frequency limit caused by TP
LC 05	Frequency limit caused by voltage
LC 03	Frequency limit caused by current
LC 06	Frequency limit caused by PFC
LC 30	Frequency limit caused by high pressure
LC 31	Frequency limit caused by low pressure
LH 07	Frequency limit caused by remote controller
--	Indoor units mode conflict(match with multi outdoor unit)
NR	No malfunction and protection

---

## 4. Error Diagnosis and Troubleshooting Without Error Code



### WARNING

Be sure to turn off unit before any maintenance to prevent damage or injury.

#### 4.1 Remote maintenance

**SUGGESTION:** When troubles occur, please check the following points with customers before field maintenance.

No.	Problem	Solution
1	Unit will not start	TS11 - TS12
2	The power switch is on but fans will not start	TS11 - TS12
3	The temperature on the display board cannot be set	TS11 - TS12
4	Unit is on but the wind is not cold(hot)	TS11 - TS12
5	Unit runs, but shortly stops	TS11 - TS12
6	The unit starts up and stops frequently	TS11 - TS12
7	Unit runs continuously but insufficient cooling(heating)	TS11 - TS12
8	Cool can not change to heat	TS11 - TS12
9	Unit is noisy	TS11 - TS12

---

## 4.2 Field maintenance

	Problem	Solution
1	Unit will not start	TS13 - TS14
2	Compressor will not start but fans run	TS13 - TS14
3	Compressor and condenser (outdoor) fan will not start	TS13 - TS14
4	Evaporator (indoor) fan will not start	TS13 - TS14
5	Condenser (Outdoor) fan will not start	TS13 - TS14
6	Unit runs, but shortly stops	TS13 - TS14
7	Compressor short-cycles due to overload	TS13 - TS14
8	High discharge pressure	TS13 - TS14
9	Low discharge pressure	TS13 - TS14
10	High suction pressure	TS13 - TS14
11	Low suction pressure	TS13 - TS14
12	Unit runs continuously but insufficient cooling	TS13 - TS14
13	Too cool	TS13 - TS14
14	Compressor is noisy	TS13 - TS14
15	Horizontal louver can not revolve	TS13 - TS14

1.Remote Maintenance	Electrical Circuit	Refrigerant Circuit
Possible causes of trouble	Power failure	
	The main power tripped	
	Loose connections	
	Faulty transformer	
	The voltage is too high or too low	
	The remote control is powered off	
	Broken remote control	
	Dirty air filter	
	Dirty condenser fins	
	The setting temperature is higher/lower than the room's(cooling/heating)	
	The ambient temperature is too high/low when the mode is cooling/heating	
	Fan mode	
	SILENCE function is activated(optional function)	
	Frosting and defrosting frequently	
Unit will not start	☆	
The power switch is on but fans will not start	☆	
The temperature on the display board cannot be set		
Unit is on but the wind is not cold(hot)		
Unit runs, but shortly stops		
The unit starts up and stops frequently	☆	☆
Unit runs continuously but insufficient cooling(heating)		☆
Cool can not change to heat		
Unit is noisy		
Test method / remedy	Test voltage	
	Close the power switch	
	Inspect connections - tighten	
	Change the transformer	
	Test voltage	
	Replace the battery of the remote control	
	Replace the remote control	
	Clean or replace	
	Clean	
	Adjust the setting temperature	
	Turn the AC later	
	Adjust to cool mode	
	Turn off SILENCE function.	
	Turn the AC later	

1.Remote Maintenance	Others					
Possible causes of trouble	Heavy load condition	Loosen hold down bolts and / or screws	Bad airproof	The air inlet or outlet of either unit is blocked	Interference from cell phone towers and remote boosters	Shipping plates remain attached
Unit will not start						
The power switch is on but fans will not start					☆	
The temperature on the display board cannot be set						
Unit is on but the wind is not cold(hot)						
Unit runs, but shortly stops						
The unit starts up and stops frequently				☆		
Unit runs continuously but insufficient cooling(heating)	☆		☆	☆		
Cool can not change to heat						
Unit is noisy		☆				☆
Test method / remedy	Check heat load	Tighten bolts or screws	Close all the windows and doors	Remove the obstacles	Reconnect the power or press <b>ON/OFF</b> button on remote control to restart operation	Remove them





2. Field Maintenance	Electrical Circuit		
Possible causes of trouble	Unit will not start	☆	Power failure
	Compressor will not start but fans run	☆	Blown fuse or varistor
	Compressor and condenser (outdoor) fan will not start	☆	Loose connections
	Evaporator (indoor) fan will not start	☆	Shorted or broken wires
	Condenser (Outdoor) fan will not start	☆	Safety device opens
	Unit runs, but shortly stops	☆	Faulty thermostat / room temperature sensor
	Compressor short-cycles due to overload	☆	Wrong setting place of temperature sensor
	High discharge pressure	☆	Faulty transformer
	Low discharge pressure	☆	Shorted or open capacitor
	High suction pressure	☆	Faulty magnetic contactor for compressor
	Low suction pressure	☆	Faulty magnetic contactor for fan
	Unit runs continuously but insufficient cooling	☆	Low voltage
	Too cool	☆	Faulty stepping motor
	Compressor is noisy	☆	Shorted or grounded compressor
	Horizontal louver can not revolve	☆	Shorted or grounded fan motor
	Test method / remedy	Test voltage	
Inspect fuse type & size			
Inspect connections - tighten		☆	
Test circuits with tester		☆	
Test continuity of safety device			
Test continuity of thermostat / sensor & wiring			☆
Place the temperature sensor at the central of the air inlet grille			☆
Check control circuit with tester			☆
Check capacitor with tester			☆
Test continuity of coil & contacts			☆
Test continuity of coil & contacts			☆
Test voltage			☆
Replace the stepping motor		☆	
Check resistance with multimeter			☆
Check resistance with multimeter			☆

## 5. Quick Maintenance by Error Code

If you do not have the time to test which specific parts are faulty, you can directly change the required parts according to the error code.

You can find the parts to replace by error code in the following table.

Part requiring replacement	Error Code								
	EH 00/EH 0A	EL 01	EH 03/EH 31/EH 32	EH 60	EH 61	EL 0C	EH 0E	EC 53	EH 0b/FH 07
Indoor PCB	✓	✓	✓	✓	✓	✓	✓	x	✓
Outdoor PCB	x	✓	x	x	x	x	x	✓	x
Indoor fan motor	x	x	✓	x	x	x	x	x	x
T1 sensor	x	x	x	✓	x	x	x	x	x
T2 Sensor	x	x	x	x	✓	✓	✓	x	x
T3 Sensor	x	x	x	x	x	x	x	x	x
T4 Sensor	x	x	x	x	x	x	x	✓	x
Reactor	x	✓	x	x	x	x	x	x	x
Compressor	x	x	x	x	x	x	x	x	x
Additional refrigerant	x	x	x	x	x	✓	✓	x	x
Water-level switch	x	x	x	x	x	x	✓	x	x
Water pump	x	x	x	x	x	x	✓	x	x
Display board	x	x	x	x	x	x	x	x	✓

Part requiring replacement	EC 54	EC 51	EC 52	EC 07	PC 00	PC 01	PC 02	PC 04	PC 03
Outdoor PCB	✓	✓	✓	✓	✓	✓	✓	✓	✓
Outdoor fan motor	x	x	x	✓	✓	x	✓	✓	x
T3 Sensor	x	x	✓	x	x	x	x	x	x
TP Sensor	✓	x	x	x	x	x	x	x	x
Reactor	x	x	x	x	x	✓	x	x	x
Compressor	x	x	x	x	✓	x	x	✓	x
IPM module board	x	x	x	x	✓	✓	✓	✓	x
Pressure protector	x	x	x	x	x	x	x	x	✓
Additional refrigerant	x	x	x	x	x	x	x	x	✓

**Note:** For certain models, outdoor PCB could not be removed separately. In this case, the outdoor electric control box should be replaced as a whole.

## 6. Troubleshooting by Error Code

### 6.1 EH 00/ EH 0A / EC 51 (EEPROM Parameter Error Diagnosis and Solution)

**Description:** Indoor or outdoor PCB main chip does not receive feedback from EEPROM chip.

**Recommended parts to prepare:**

- Indoor PCB
- Outdoor PCB

**Troubleshooting and repair:**

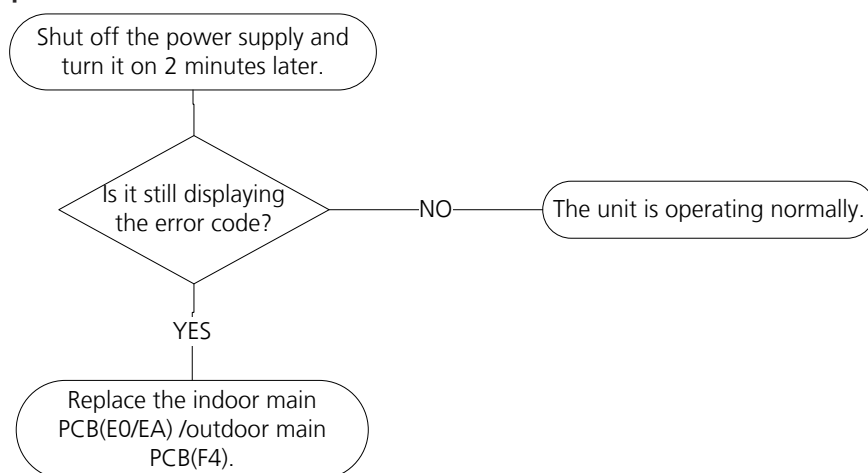

**Remarks:**

**EEPROM:** A read-only memory whose contents can be erased and reprogrammed using a pulsed voltage.

The location of the EEPROM chip on the indoor and outdoor PCB is shown in the following two images:

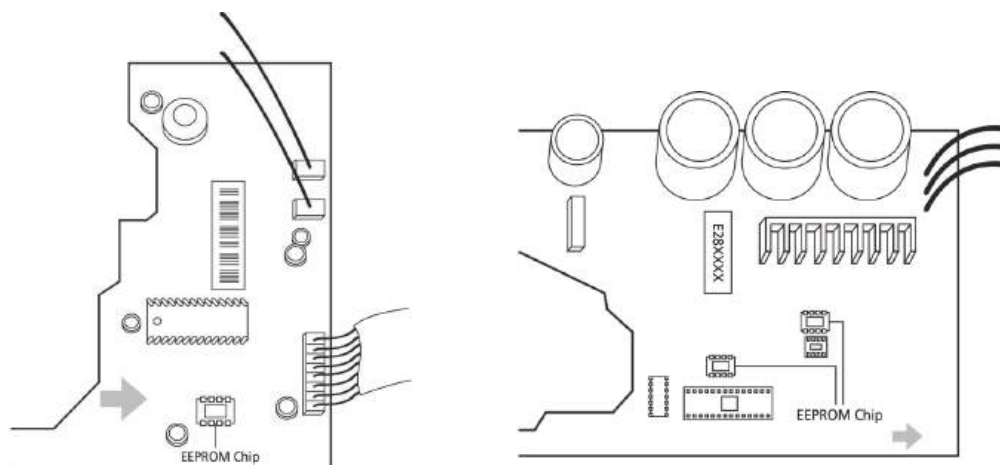

**Note:** For certain models, outdoor PCB could not be removed separately. In this case, the outdoor electric control box should be replaced as a whole. This pictures are only for reference, actual appearance may vary.

Troubleshooting and repair of compressor driven chip EEPROM parameter error and communication error between outdoor main chip and compressor driven chip are same as EC 51.

## 6.2 EL 01 (Indoor and Outdoor Unit Communication Error Diagnosis and Solution)

**Description:** Indoor unit can not communicate with outdoor unit

**Recommended parts to prepare:**

- Indoor PCB
- Outdoor PCB
- Reactor

**Troubleshooting and repair:**

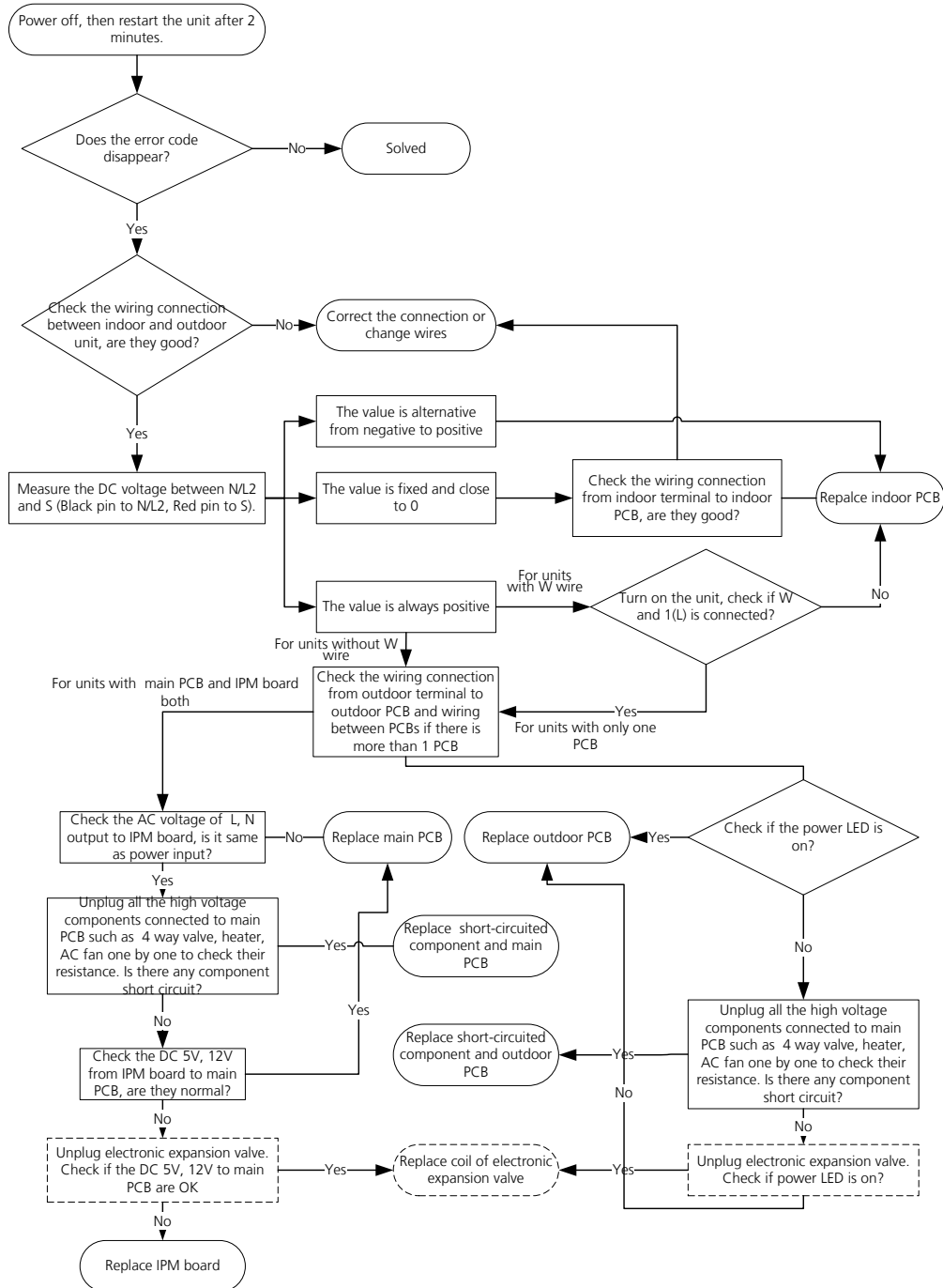

**Note:** For certain models, outdoor PCB could not be removed separately. In this case, the outdoor electric control box should be replaced as a whole.

---

**Remarks:**

- Use a multimeter to test the DC voltage between 2 port(or S or L2 port) and 3 port(or N or S port) of outdoor unit. The red pin of multimeter connects with 2 port(or S or L2 port) while the black pin is for 3 port(or N or S port).
- When AC is operating normally, the voltage is moving alternately as positive values and negative values
- If the outdoor unit has malfunction, the voltage has always been the positive value.
- While if the indoor unit has malfunction, the voltage has always been a certain value.

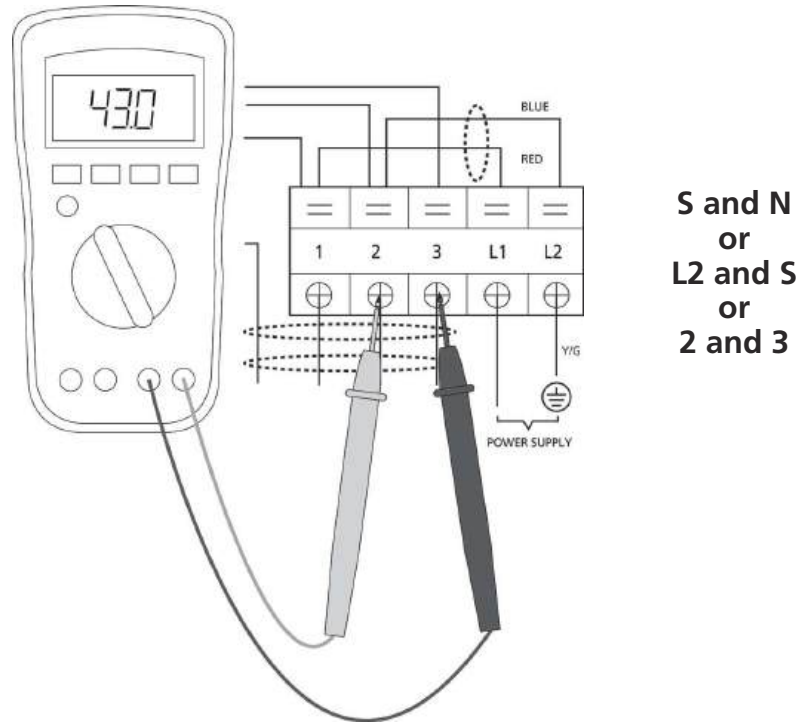

- Use a multimeter to test the resistance of the reactor which does not connect with capacitor.
- The normal value should be around zero ohm. Otherwise, the reactor must have malfunction.

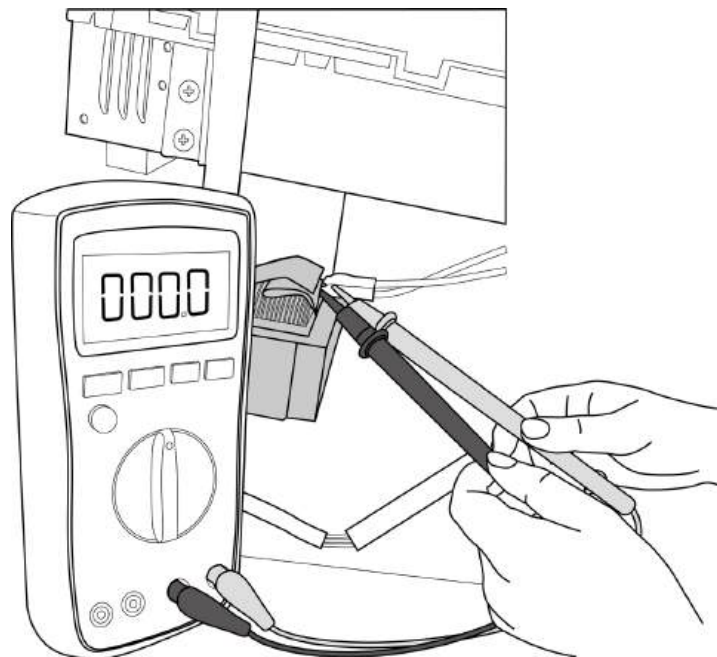

**Note:** The picture and the value are only for reference, actual condition and specific value may vary.

### 6.3 EH 03 / EH 31/EH 32/ EC 07 (Fan Speed Is Operating Outside of Normal Range Diagnosis and Solution)

**Description:** When indoor / outdoor fan speed keeps too low or too high for a certain time, the unit ceases operation and the LED displays the failure.

**Recommended parts to prepare:**

- Connection wires
- Fan assembly
- Fan motor
- PCB

**Troubleshooting and repair:**

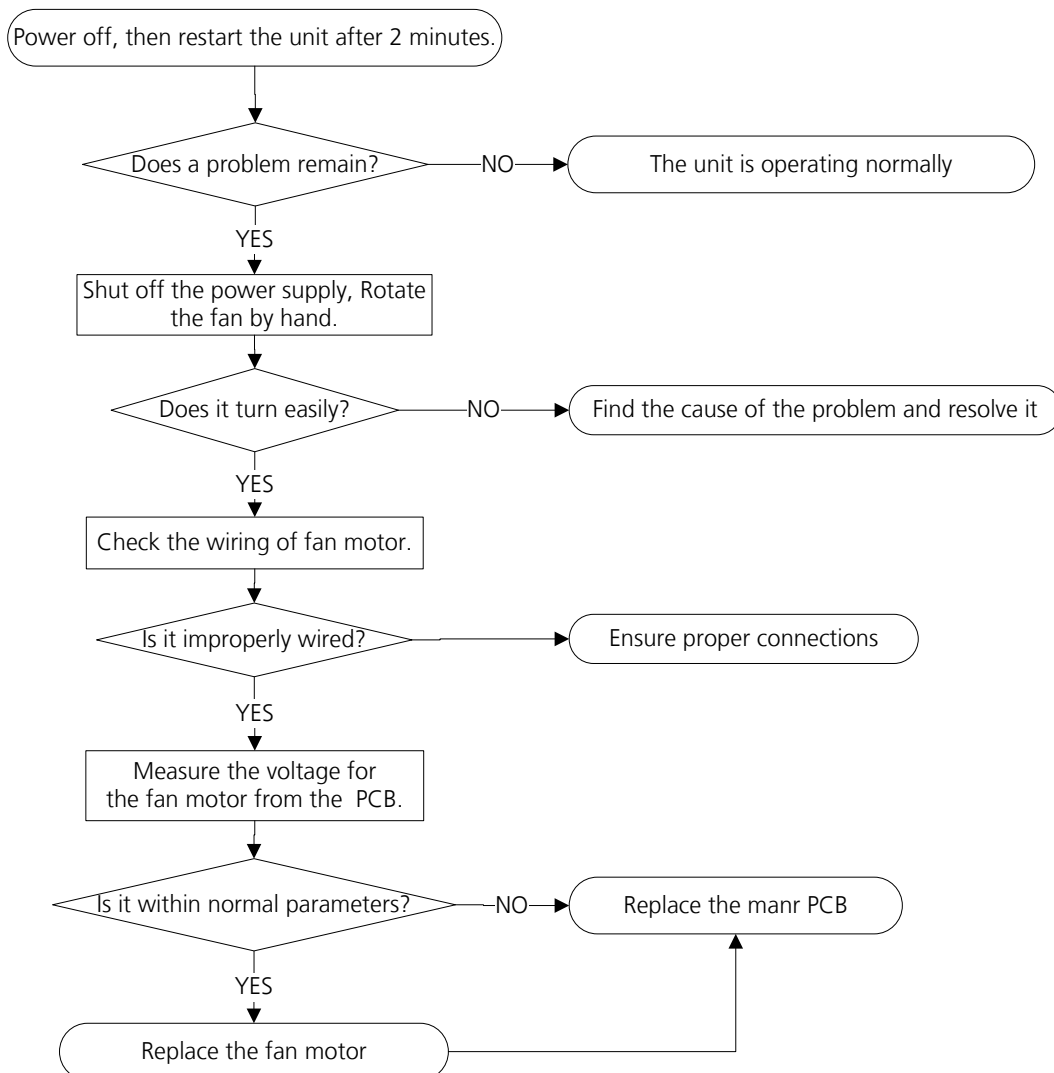

**Note:** For certain models, outdoor PCB could not be removed separately. In this case, the outdoor electric control box should be replaced as a whole.

**Index:**

**1. Indoor or Outdoor DC Fan Motor(control chip is in fan motor)**

Power on and when the unit is in standby, measure the voltage of pin1-pin3, pin4-pin3 in fan motor connector. If the value of the voltage is not in the range showing in below table, the PCB must has problems and need to be replaced.

No.	Color	Signal	Voltage
1	Red	Vs/Vm	192V~380V
2	---	---	---
3	Black	GND	0V
4	White	Vcc	13.5-16.5V
5	Yellow	Vsp	0~6.5V
6	Blue	FG	13.5-16.5V

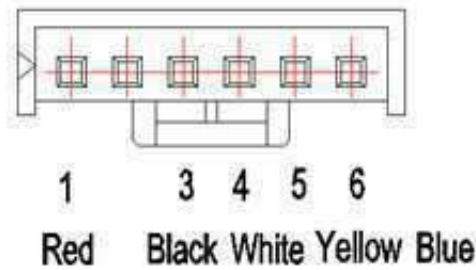

**2.Indoor DC Fan IPM Board (Duct and Ceiling-floor Unit)**

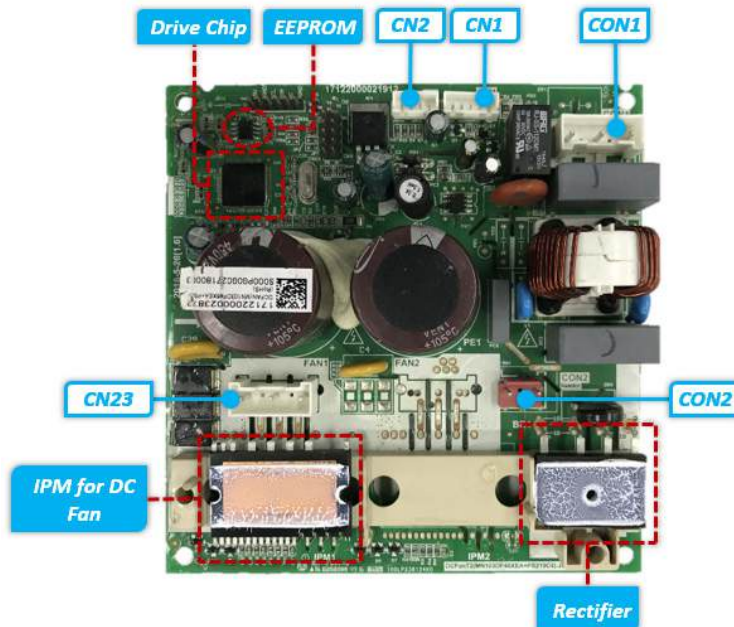

Port	Description	Parameter	Remark
CON1	Power input for the PCB	230V/AC	
CN1	Communication with main PCB	DC	
CN2	Test port	5V/DC	For debugging board
CN23	UVW output for DC fan motor		
CON2	Ports for reactor		

**CN1 Communication with main PCB**



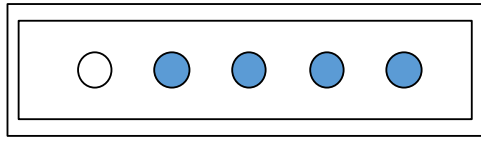

**5 4 3 2 1**

NO.	Signal	Voltage
1	Vcc	+15V
2	GND	
3	TXD	0~6V
4	RXD	0~15V
5	--	--

### 3. Outdoor DC Fan Motor (control chip is in outdoor PCB)

Release the UVW connector. Measure the resistance of U-V, U-W, V-W. If the resistance is not equal to each other, the fan motor must have problems and need to be replaced. otherwise the PCB must have problems and need to be replaced.

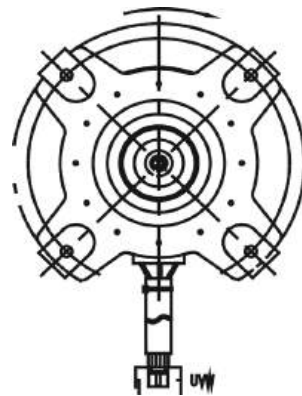

## 6.4 EH 60/EH 61/EC 53/EC 52/EC 54 (Open Circuit or Short Circuit of Temperature Sensor Diagnosis and Solution)

**Description:** If the sampling voltage is lower than 0.06V or higher than 4.94V, the LED displays the failure.

**Recommended parts to prepare:**

- Connection wires
- Sensors
- PCB

**Troubleshooting and repair:**

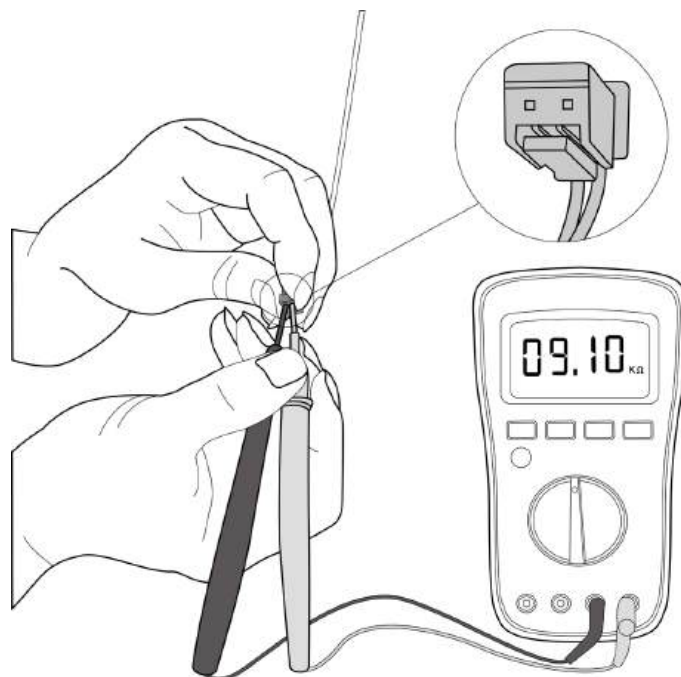
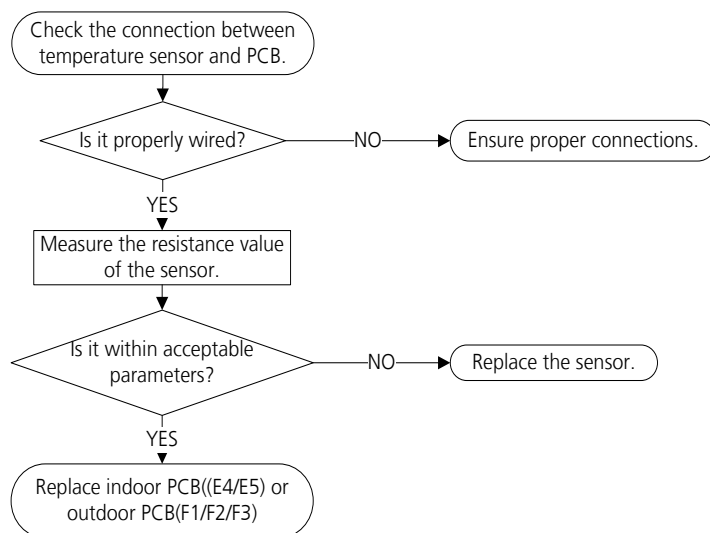

**Note:** For certain models, outdoor PCB could not be removed separately. In this case, the outdoor electric control box should be replaced as a whole. This picture and the value are only for reference, actual appearance and value may vary

## 6.5 EL 0C (Refrigerant Leakage Detection Diagnosis and Solution)

**Description:** Define the evaporator coil temperature T2 of the compressor just starts running as Tcool.

In the beginning 5 minutes after the compressor starts up, if  $T2 < T_{cool} - 1^{\circ}\text{C}$  ( $1.8^{\circ}\text{F}$ ) does not keep continuous 4 seconds and compressor running frequency higher than 50Hz does not keep for 3 minutes, and this situation happens 3 times, the display area will show "EL 0C" and AC will turn off.

### Recommended parts to prepare:

- T2 sensor
- Indoor PCB
- Additional refrigerant

### Troubleshooting and repair:

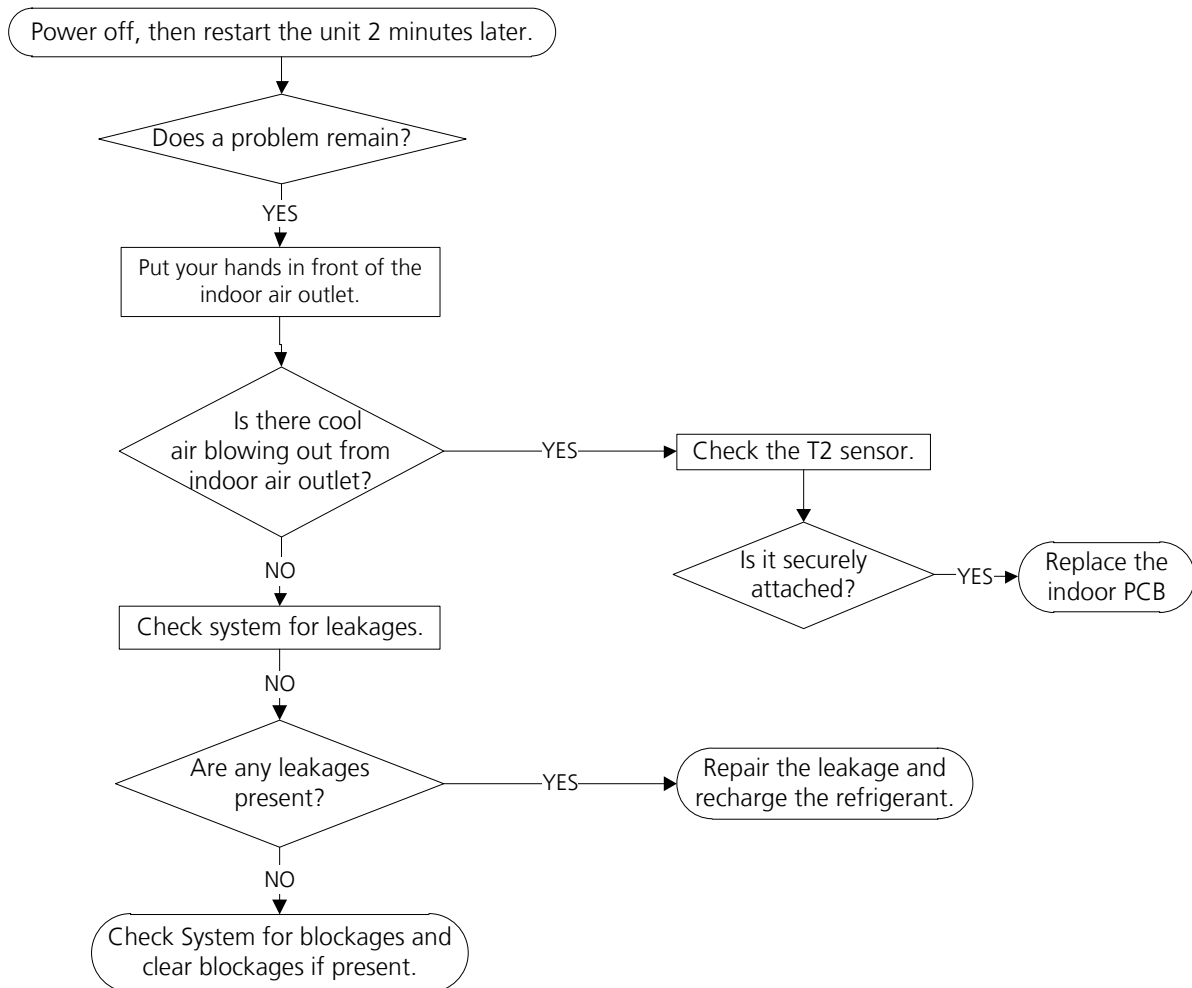

## 6.6 EH 0E(Water-Level Alarm Malfunction Diagnosis and Solution)

**Description:** If the sampling voltage is not 5V, the LED displays the failure code.

**Recommended parts to prepare:**

- Connection wires
- Water-level switch
- Water pump
- Indoor PCB

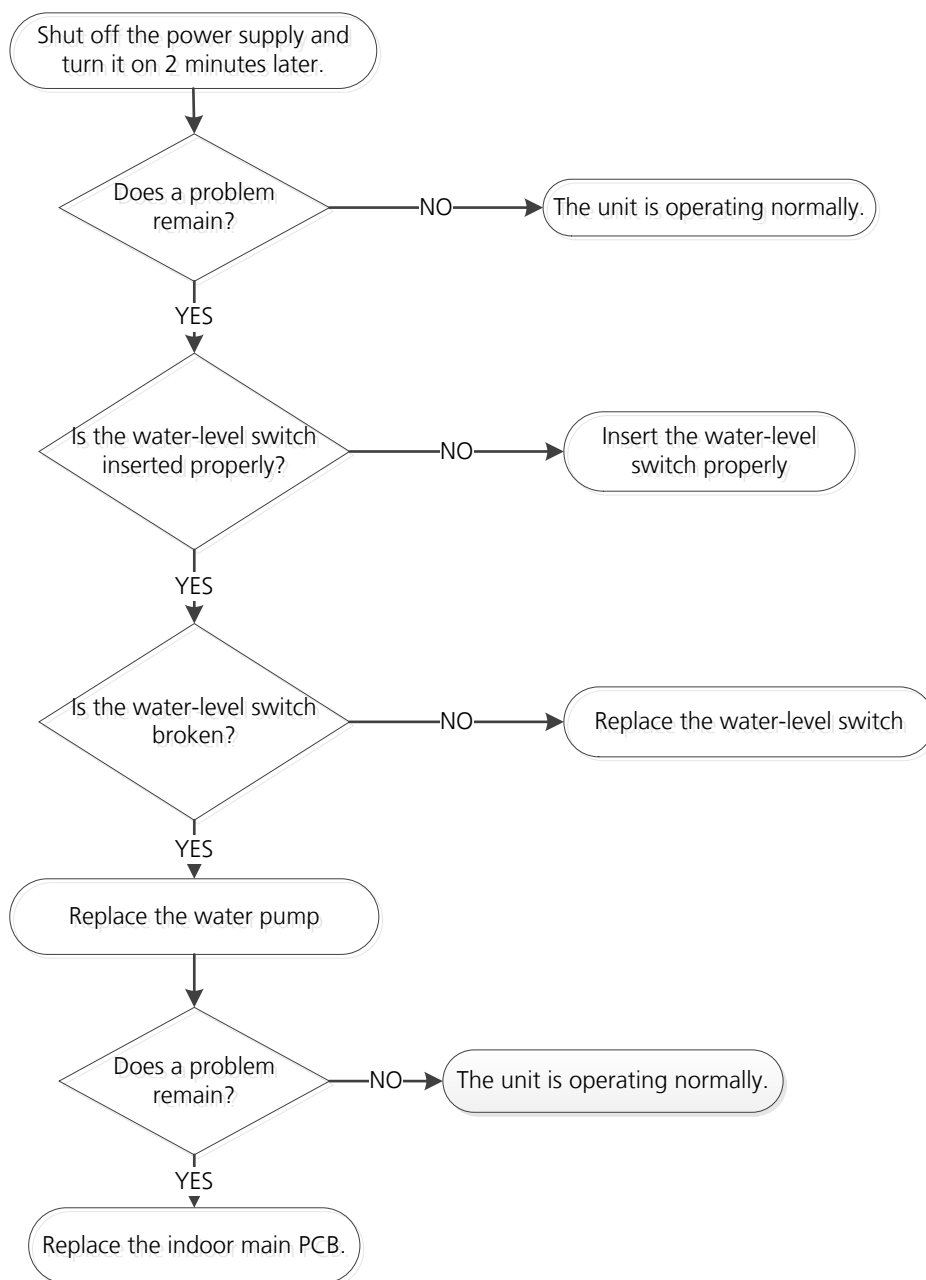

## 6.7 PC 00(IPM malfunction or IGBT over-strong current protection Diagnosis and Solution)

**Description:** When the voltage signal the IPM sends to the compressor drive chip is abnormal, the display LED shows “PC 00” and the AC turn off.

### Recommended parts to prepare:

- Connection wires
- IPM module board
- Outdoor fan assembly
- Compressor
- Outdoor PCB

### Troubleshooting and repair:

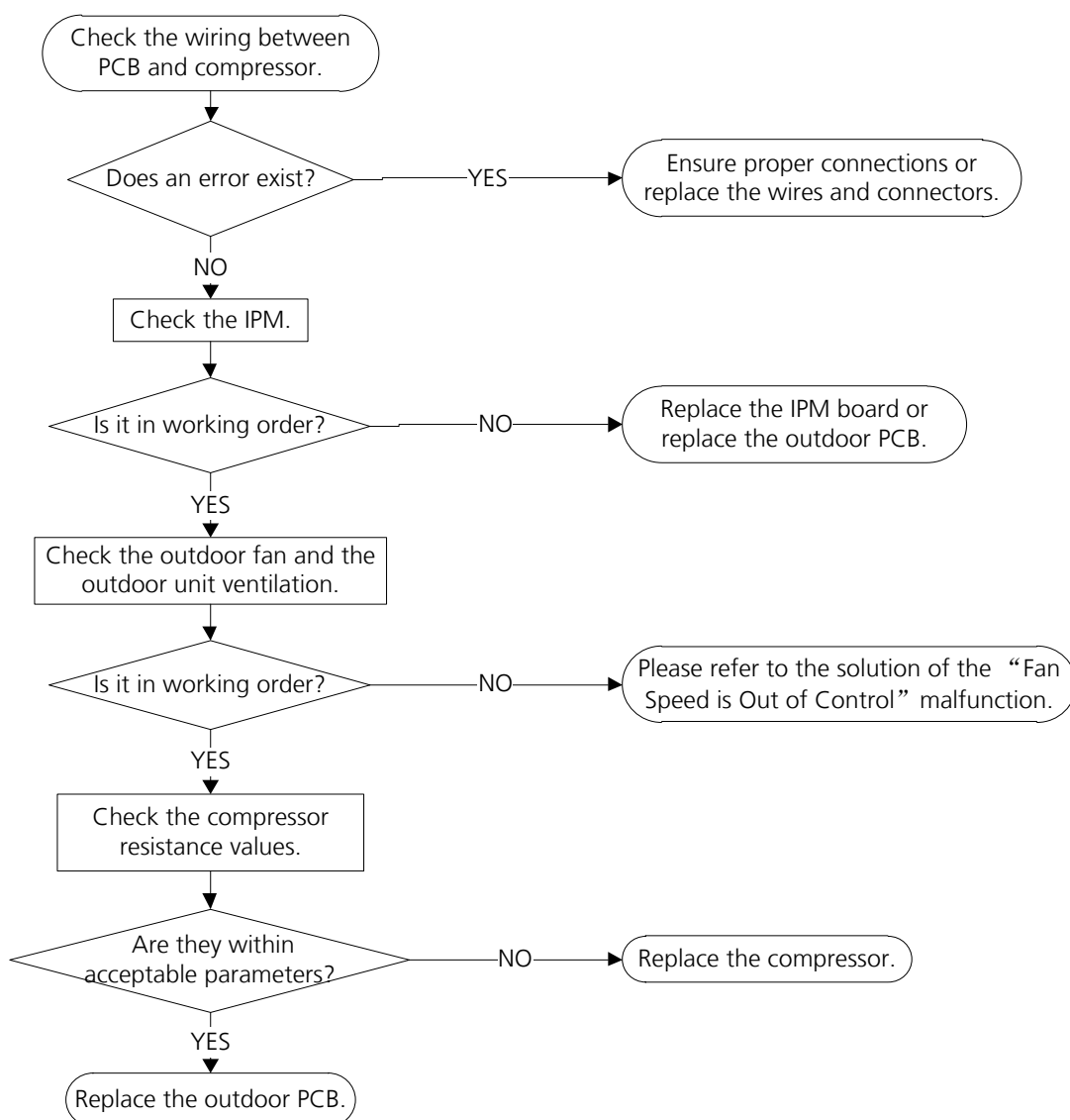

**Note:** For certain models, outdoor PCB could not be removed separately. In this case, the outdoor electric control box should be replaced as a whole.

## 6.8 PC 01(Over voltage or too low voltage protection Diagnosis and Solution)

**Description:** Abnormal increases or decreases in voltage are detected by checking the specified voltage detection circuit.

### Recommended parts to prepare:

- Power supply wires
- IPM module board
- PCB
- Reactor

### Troubleshooting and repair:

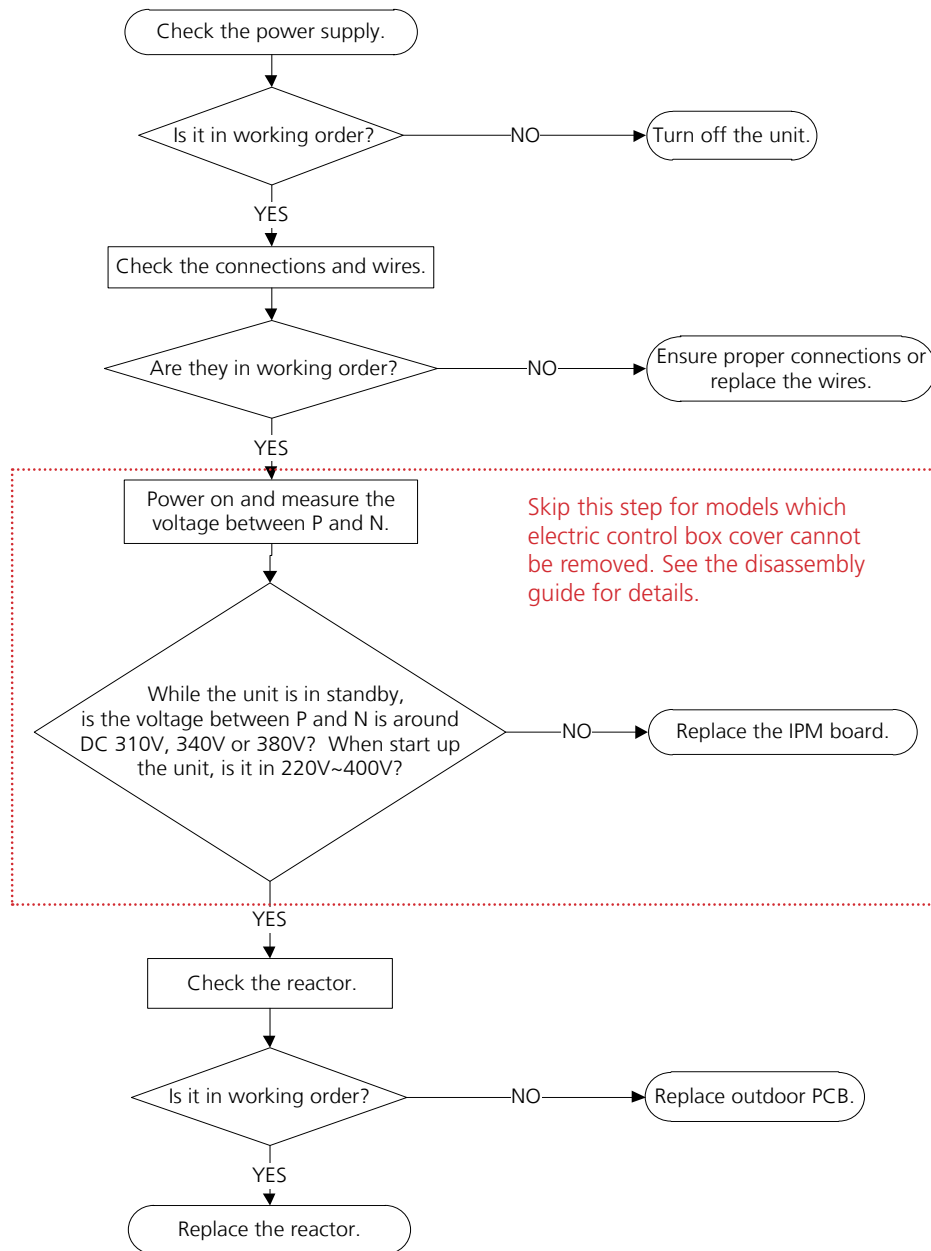

**Note:** For certain models, outdoor PCB could not be removed separately. In this case, the outdoor electric control box should be replaced as a whole.

## 6.9 PC 04(Inverter compressor drive error Diagnosis and Solution)

**Description:** An abnormal inverter compressor drive is detected by a special detection circuit, including communication signal detection, voltage detection, compressor rotation speed signal detection and so on.

### Recommended parts to prepare:

- Connection wires
- IPM module board
- Outdoor fan assembly
- Compressor
- Outdoor PCB

### Troubleshooting and repair:

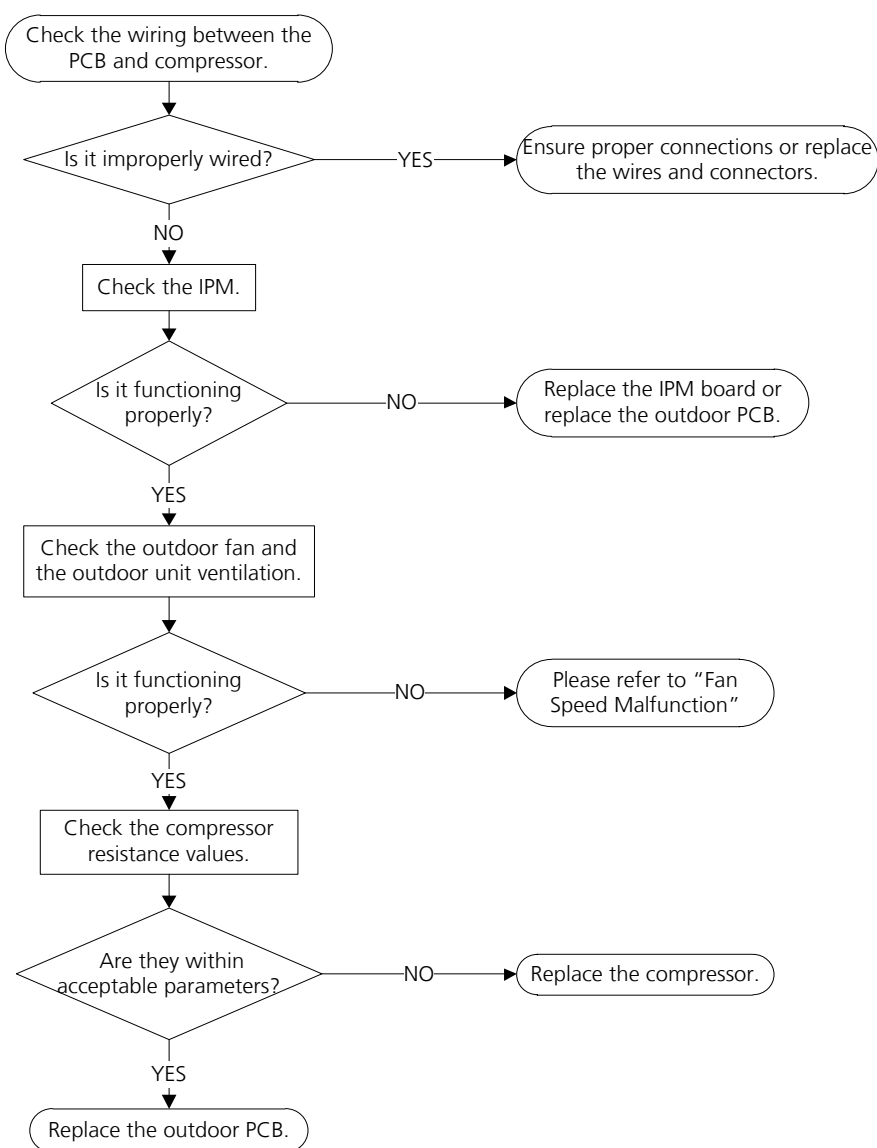

**Note:** For certain models, outdoor PCB could not be removed separately. In this case, the outdoor electric control box should be replaced as a whole.

---

## 6.10 PC 03(High pressure protection or Low Pressure Protection Diagnosis and Solution)

**Description:** Outdoor pressure switch cut off the system because high pressure is higher than 4.4 MPa or outdoor pressure switch cut off the system because low pressure is lower than 0.13 MPa, the LED displays the failure code.

**Recommended parts to prepare:**

- Connection wires
- Pressure switch
- Outdoor fan
- Outdoor main PCB
- Refrigerant

**Troubleshooting and repair:**



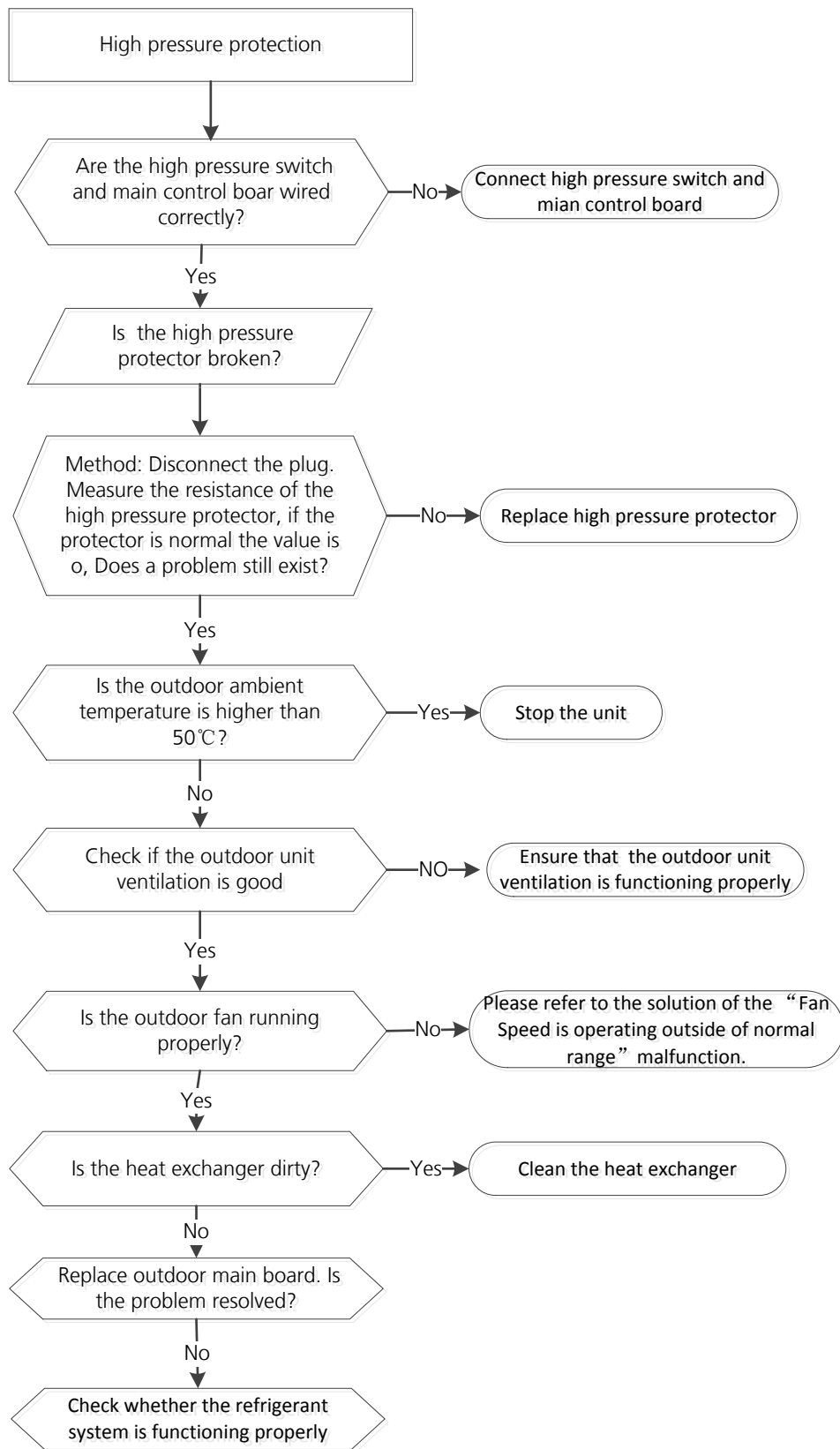

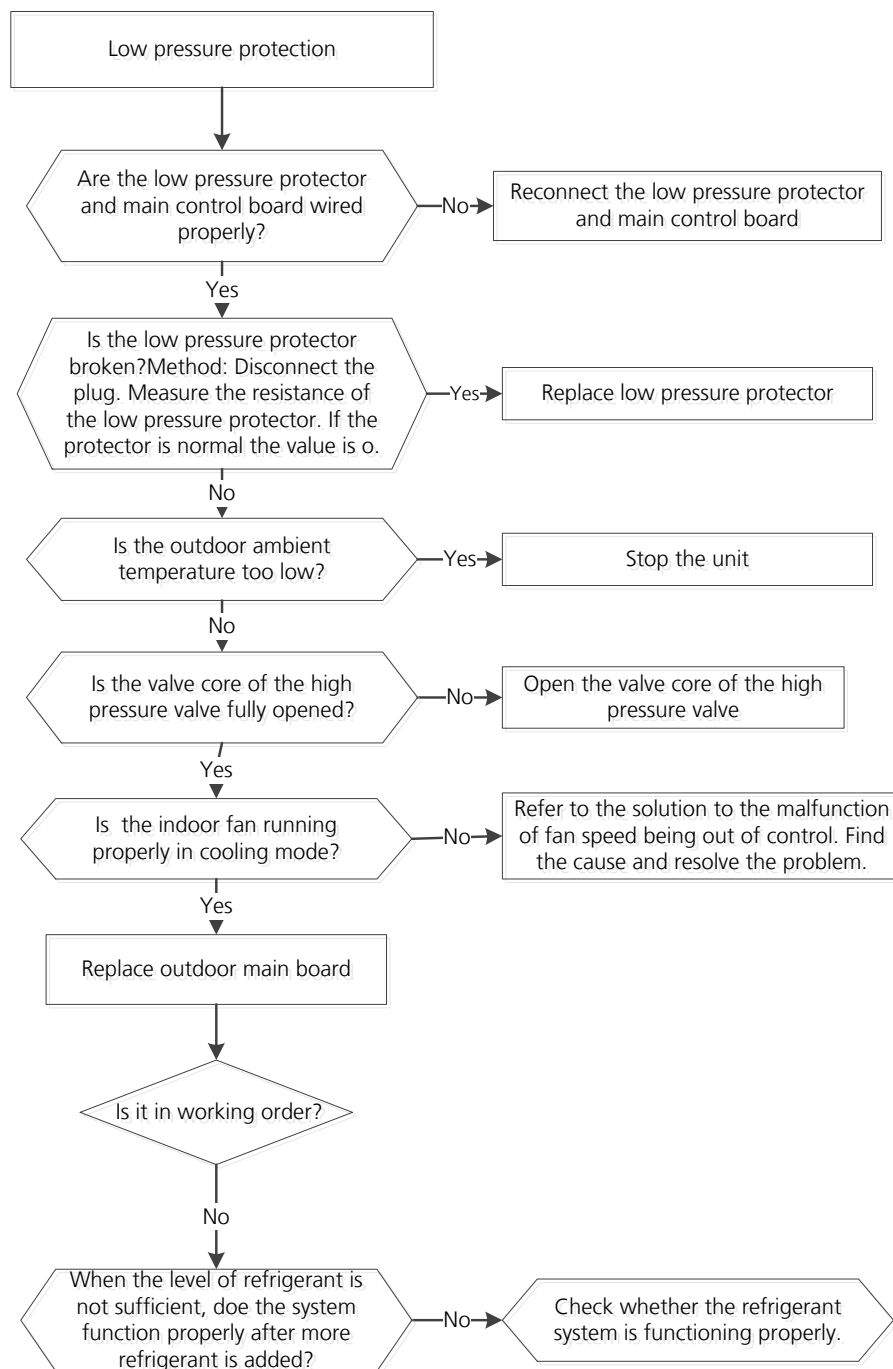

**Note:** For certain models, outdoor PCB could not be removed separately. In this case, the outdoor electric control box should be replaced as a whole.

## 6.11 PC 02(Top temperature protection of compressor or High temperature protection of IPM module diagnosis and solution)

**Description:** For some models with overload protection, If the sampling voltage is not 5V, the LED will display the failure. If the temperature of IPM module is higher than a certain value, the LED displays the failure code.

### Recommended parts to prepare:

- Connection wires
- Outdoor PCB
- IPM module board
- High pressure protector
- System blockages

### Troubleshooting and repair:

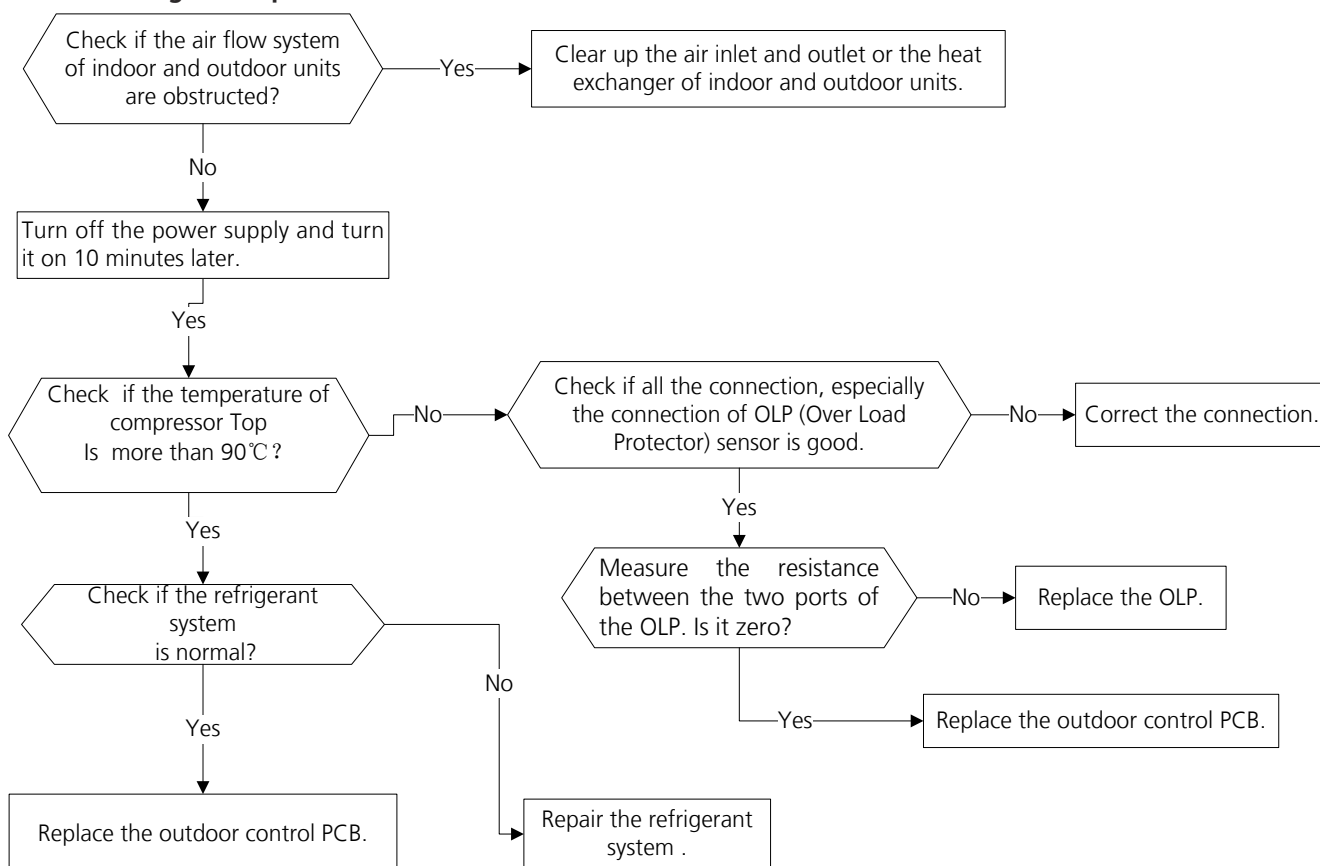

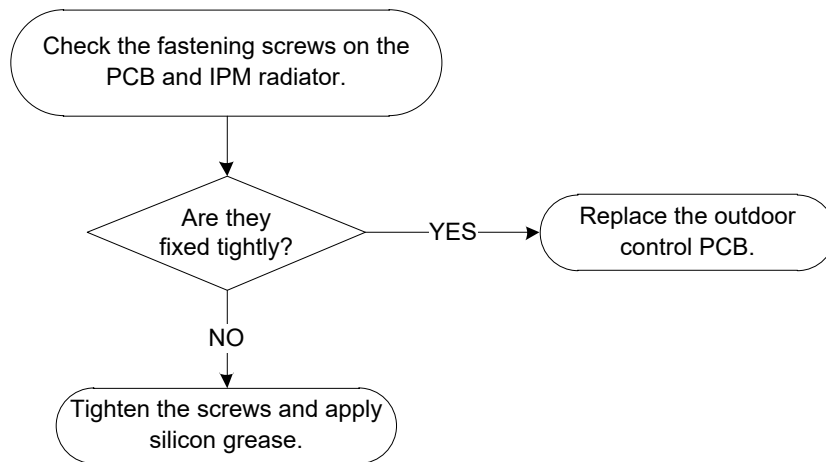

## 6.12 PC 0L (Low ambient temperature protection)

**Description:** It is a protection function. When compressor is off, outdoor ambient temperature(T4) is lower than -35°C. for 10s, the AC will stop and display the failure code.

When compressor is on, outdoor ambient temperature(T4) is lower than -40°C. for 10s, the AC will stop and display the failure code.

When outdoor ambient temperature(T4) is no lower than -32°C. for 10s, the unit will exit protection.

## 6.13 EC 0d(Outdoor unit malfunction Diagnosis and Solution)

**Description:** The indoor unit detect the outdoor unit is error.

**Recommended parts to prepare:**

- Outdoor unit

**Troubleshooting and repair:**

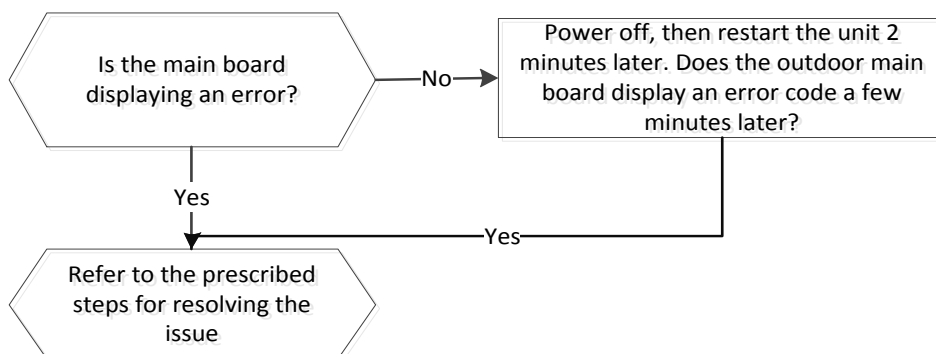

---

## 6.14 EH 0b(Communication error between display board and main board diagnosis and solution)

**Description:** Indoor PCB does not receive feedback from the display board.

**Recommended parts to prepare:**

- Communication wire
- Indoor PCB
- Display board

**Troubleshooting and repair:**

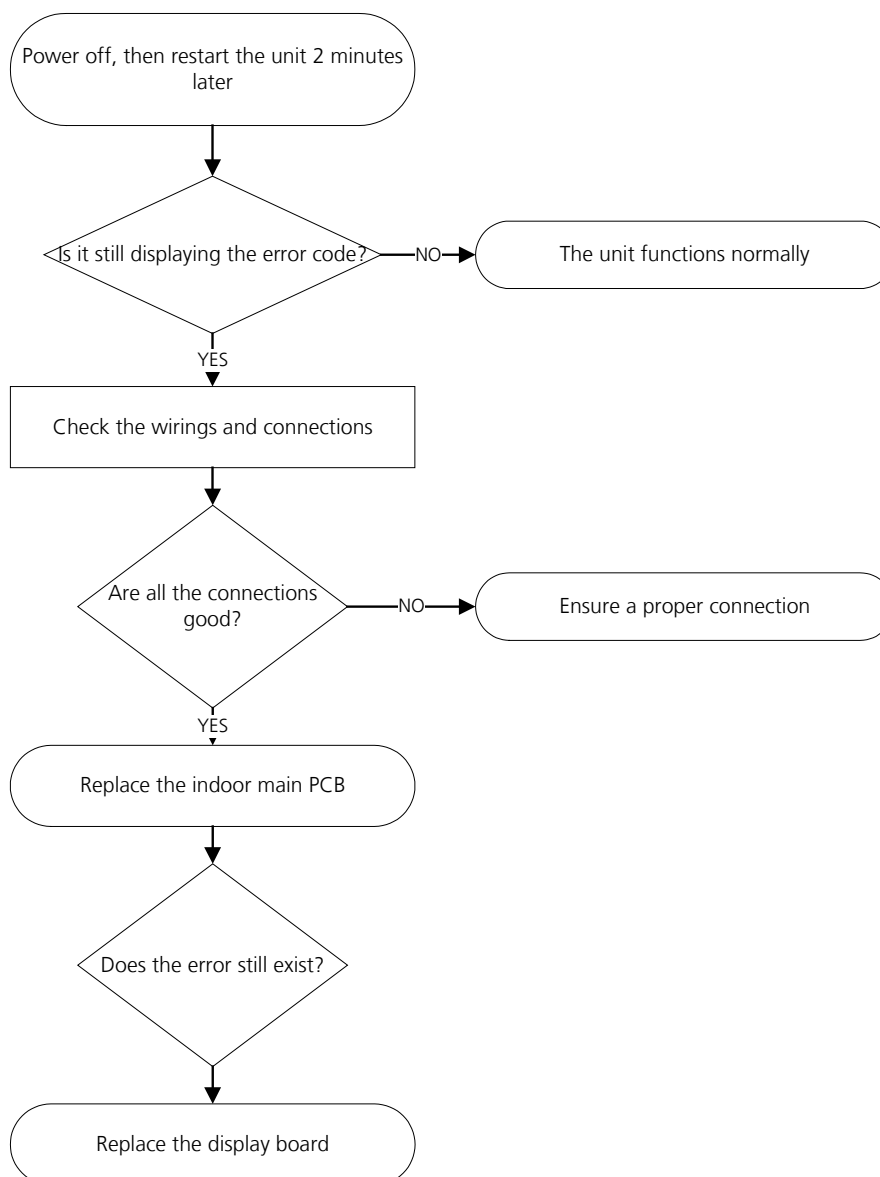

---

## 6.15 EH b3 (Communication error between wired controller and indoor unit Diagnosis and Solution

**Description:** If Indoor PCB does not receive feedback from wired controller, the error displays on the wired controller

**Recommended parts to prepare:**

- Connection wires
- Indoor PCB
- Wired controller

**Troubleshooting and repair:**

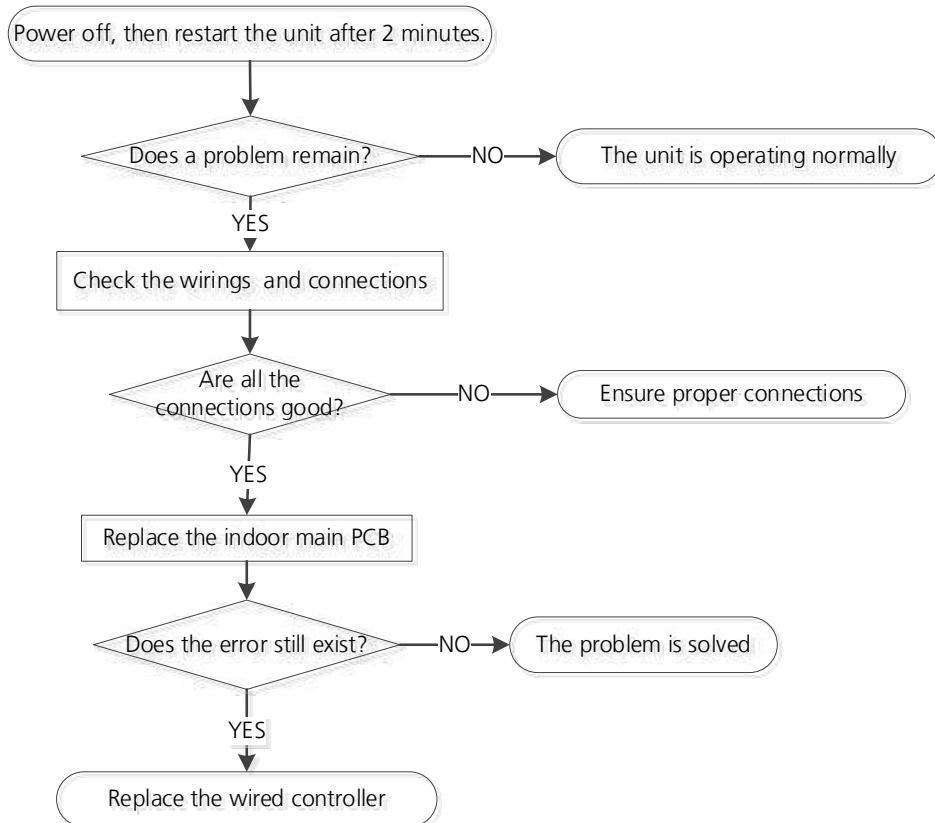

---

## 6.16 EH bA(Communication malfunction between external fan module and indoor unit)/ EH 3A(External fan DC bus voltage is too low protection)/ EH 3b(External fan DC bus voltage is too high fault) diagnosis and solution

**Description:** Indoor unit does not receive the feedback from external fan module during 150 seconds.  
or Indoor unit receives abnormal increases or decreases in voltage from external fan module.

**Recommended parts to prepare:**

- Indoor main PCB

**Troubleshooting and repair:**

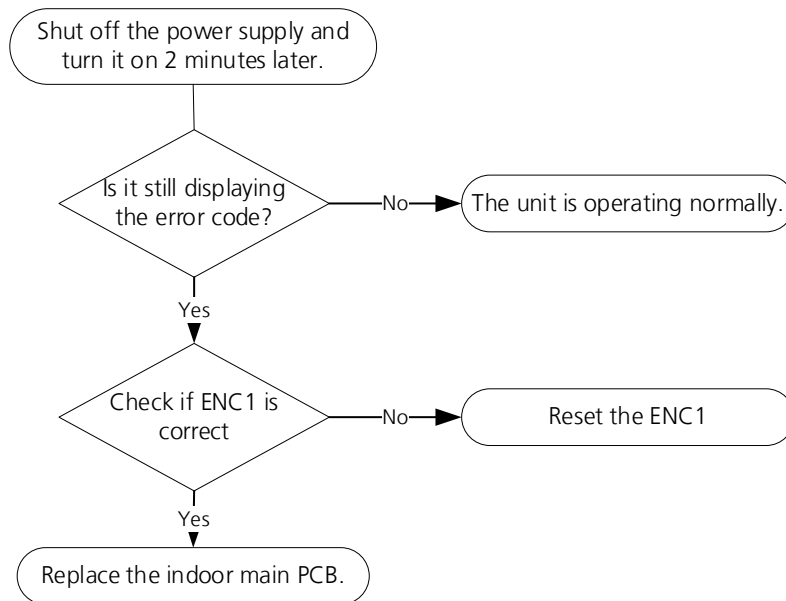

---

## 6.17 FH 07(Communication malfunction between indoor unit and auto-lifting panel) diagnosis and solution

**Description:** Indoor PCB does not get the feedback from the PCB of auto-lifting panel.

**Recommended parts to prepare:**

- Connection wires
- PCB of auto-lifting panel
- Indoor PCB

**Troubleshooting and repair:**

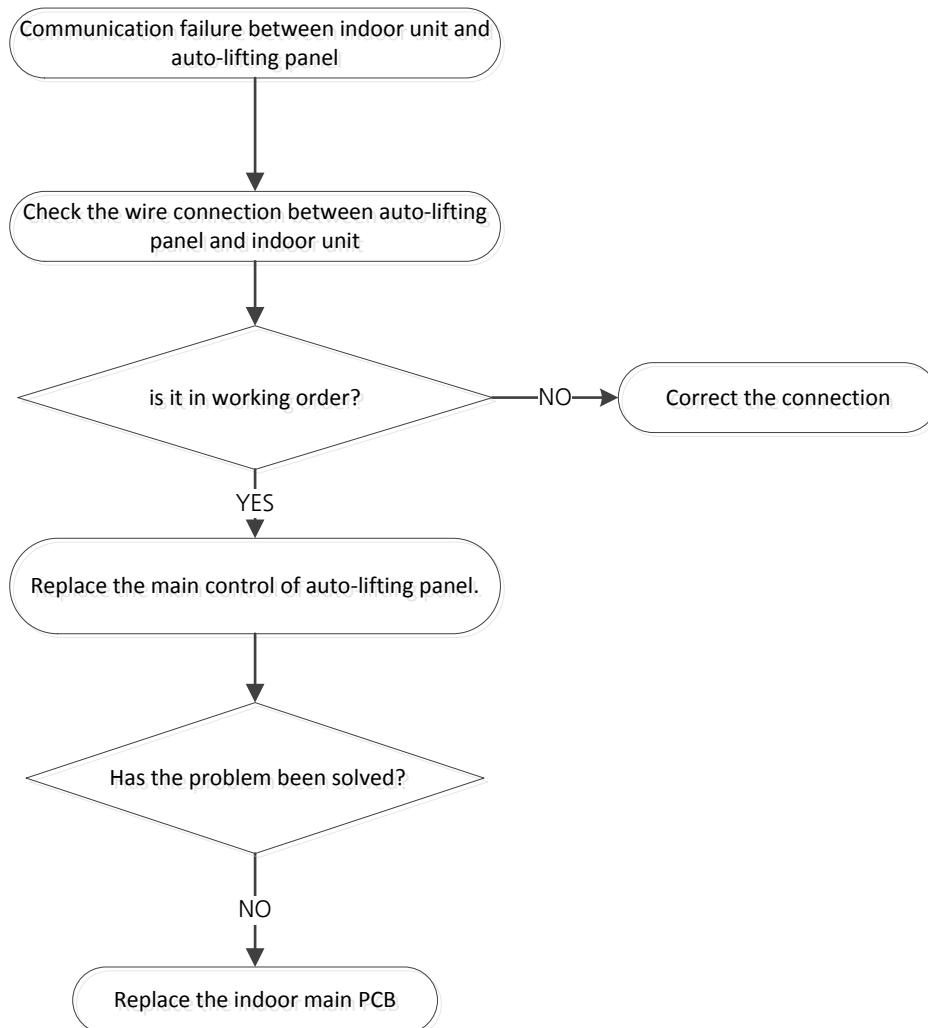



## 8. Check Procedures

### 8.1 Temperature Sensor Check

#### **!** WARNING

**Be sure to turn off all power supplies or disconnect all wires to avoid electric shock. Operate after compressor and coil have returned to normal temperature in case of injury.**

1. Disconnect the temperature sensor from PCB (Refer to Chapter 5&6. Indoor&Outdoor Unit Disassembly).
2. Measure the resistance value of the sensor using a multi-meter.
3. Check corresponding temperature sensor resistance value table (Refer to Chapter 8. Appendix).

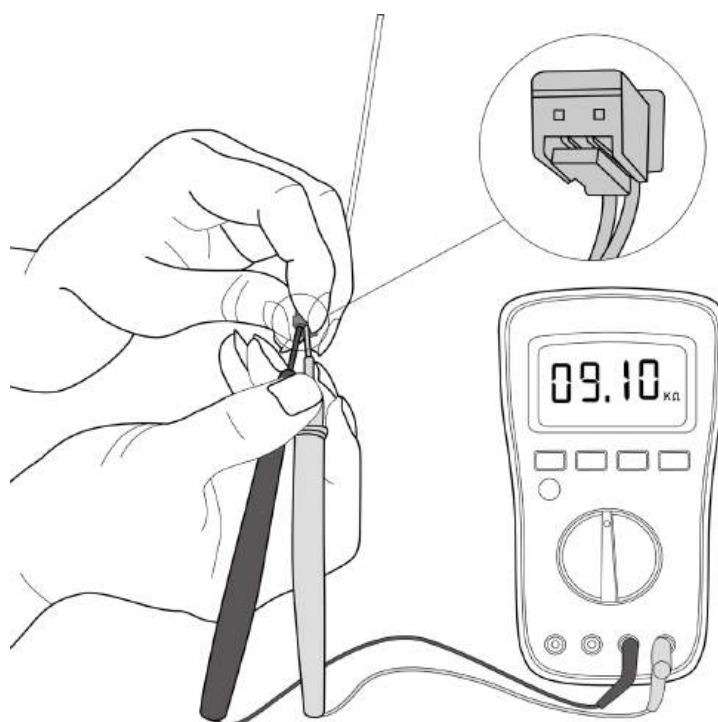

**Note: The picture and the value are only for reference, actual condition and specific value may vary.**

### 8.2 Compressor Check

1. Disconnect the compressor power cord from outdoor PCB (Refer to Chapter 6. Outdoor Unit Disassembly).
2. Measure the resistance value of each winding using a multi-meter.
3. Check the resistance value of each winding in the following table.

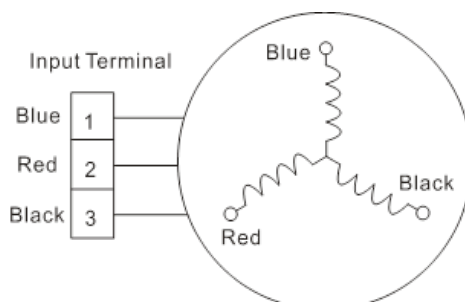

Resistance Value	KSN98D64UFZ3	KSN140D21UFZ	KTM240D43UKT	KTM240D57UMT
Blue-Red	2.7Ω	1.28Ω	1.03Ω	0.62Ω
Blue-Black				
Red-Black				

Resistance Value	KTF250D22UMT ATF235D22TMT	KSN140D58UFZ	KTF310D43UMT ATF310D43TMT	KTQ420D1UMU ATQ420D1SN5A1
Blue-Red	0.75Ω	1.86Ω	0.65Ω	0.37Ω
Blue-Black				
Red-Black				

Resistance Value	ATM150D23TFZ	ATH307CDRC8DUL	KSK103D33UEZ3	KTN110D42UFZ
Blue-Red	1.72Ω	1.09Ω	2.13Ω	1.82Ω
Blue-Black				
Red-Black				

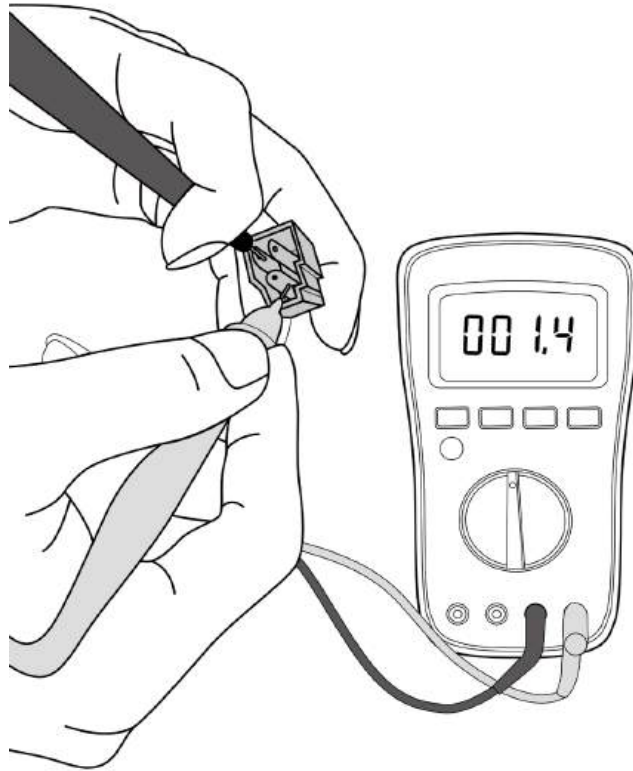

**Note:** The picture and the value are only for reference, actual condition and specific value may vary.

### 8.3 IPM Continuity Check

#### **⚠ WARNING**

**Electricity remains in capacitors even when the power supply is off. Ensure the capacitors are fully discharged before troubleshooting.**

1. Turn off outdoor unit and disconnect power supply.
2. Discharge electrolytic capacitors and ensure all energy-storage unit has been discharged.
3. Disassemble outdoor PCB or disassemble IPM board.
4. Measure the resistance value between P and U(V, W, N); U(V, W) and N.

Digital tester		Resistance value	Digital tester		Resistance value
(+)Red	(-)Black		(+)Red	(-)Black	
P	N	∞ (Several MΩ)	U	N	∞ (Several MΩ)
	U		V		
	V		W		
	W		-		

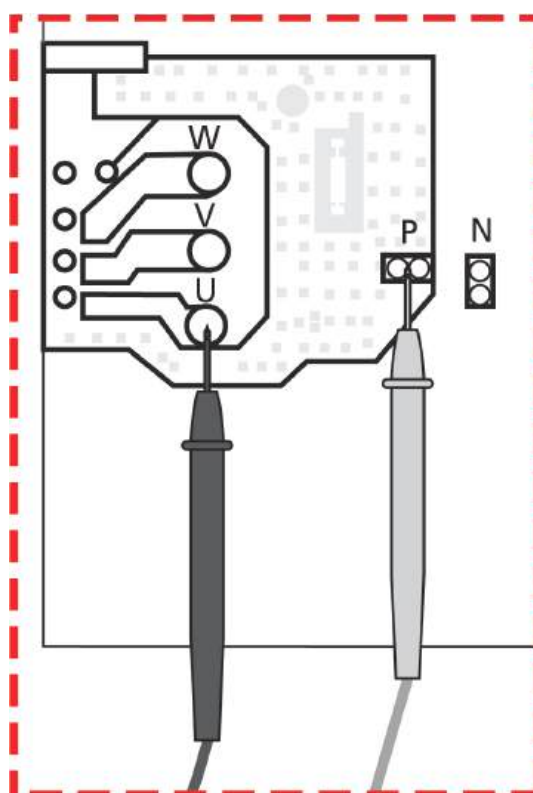

**Note:** The picture and the value are only for reference, actual condition and specific value may vary.

---

# Indoor Unit Disassembly-New Console

## Contents

<b>1.</b>	<b>Indoor Unit Disassembly .....</b>	<b>1</b>
1.1	Filter.....	2
1.2	Display Board .....	4
1.3	Panel Frame Subassembly .....	5
1.4	Upper air outlet frame assembly .....	6
1.5	Lower air outlet frame assembly .....	8
1.6	Evaporator.....	9
1.7	Fan Motor and Fan .....	10
1.8	Electrical Parts .....	11

# 1. Indoor Unit Disassembly

## 1.1 Filter

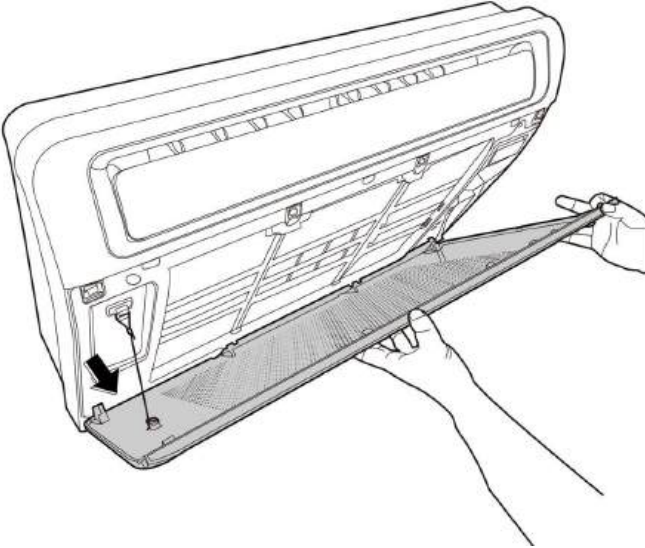
Procedure	Illustration
<p>1) Hold the both sides of front panel and open the front panel. (see CJ_CONSOLE2_001)</p>	 <p>CJ_CONSOLE2_001</p>
<p>2) Remove the string from the hook. (see CJ_CONSOLE2_002)</p>	 <p>CJ_CONSOLE2_002</p>

Note: This section is for reference only. Actual unit appearance may vary.

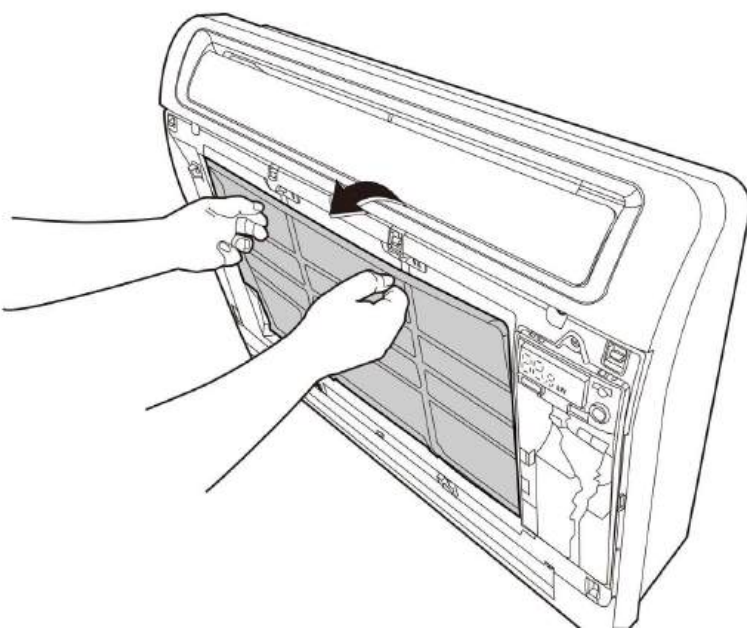
Procedure	Illustration
<p>3) Pull out the filter (see CJ_CONSOLE2_003)</p>	 <p data-bbox="925 1008 1181 1041">CJ_CONSOLE2_003</p>

**Note:** This section is for reference only. Actual unit appearance may vary.

## 1.2 Display Board

**Note:** Remove the front panel (refer to 1.1. filter) before disassembling display board.

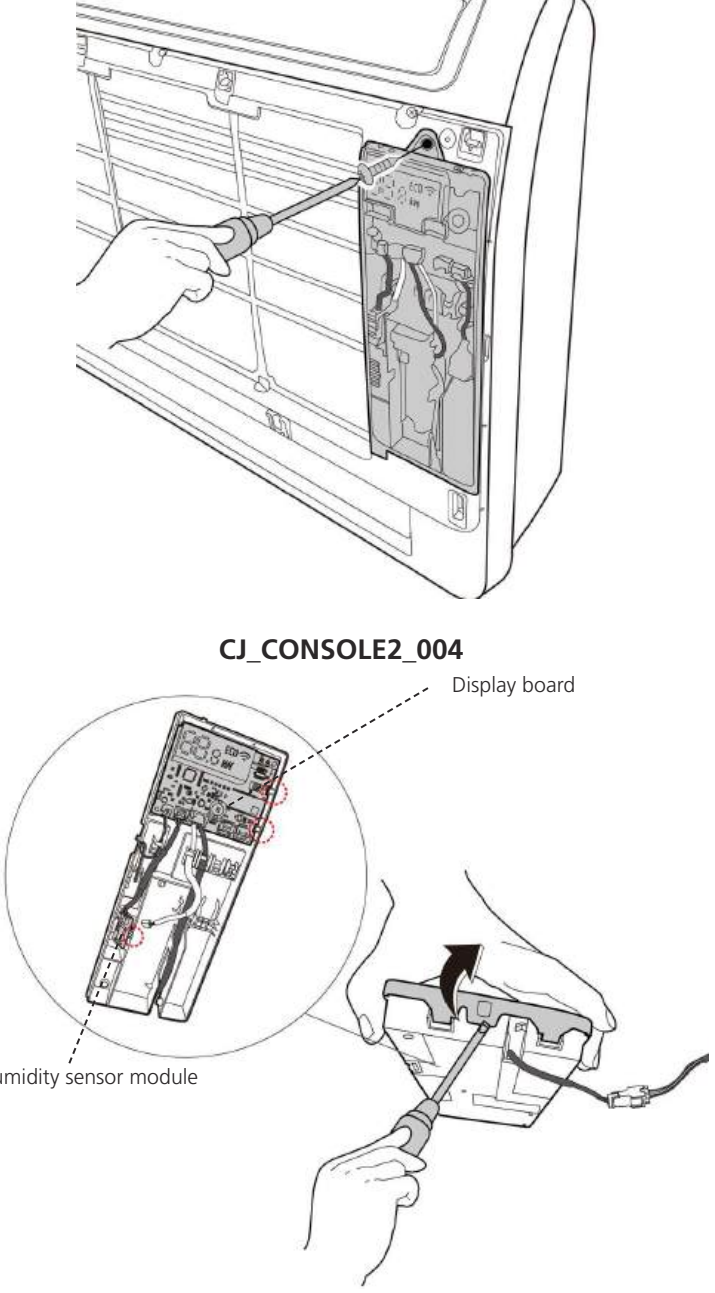
Procedure	Illustration
<p>1) Remove 1 screw and remove the display box subassembly(see CJ_CONSOLE2_004)</p> <p>2) Pry open the display light box.(see CJ_CONSOLE2_005)</p> <p>3) Remove the display board and the humidity sensor module. (see CJ_CONSOLE2_005)</p>	 <p>The illustration is divided into two parts. The top part, labeled <b>CJ_CONSOLE2_004</b>, shows a hand using a screwdriver to remove a screw from the back of a rectangular display box subassembly mounted on a wall. The bottom part, labeled <b>CJ_CONSOLE2_005</b>, shows a hand using a pry bar to lift the top cover of the display box. A circular inset provides a magnified view of the internal components, with dashed lines pointing to the <b>Display board</b> and the <b>Humidity sensor module</b>.</p>

**Note:** This section is for reference only. Actual unit appearance may vary.



### 1.3 Panel Frame Subassembly

**Note:** Remove the front panel (refer to 1.1. filter) before disassembling panel frame subassembly.

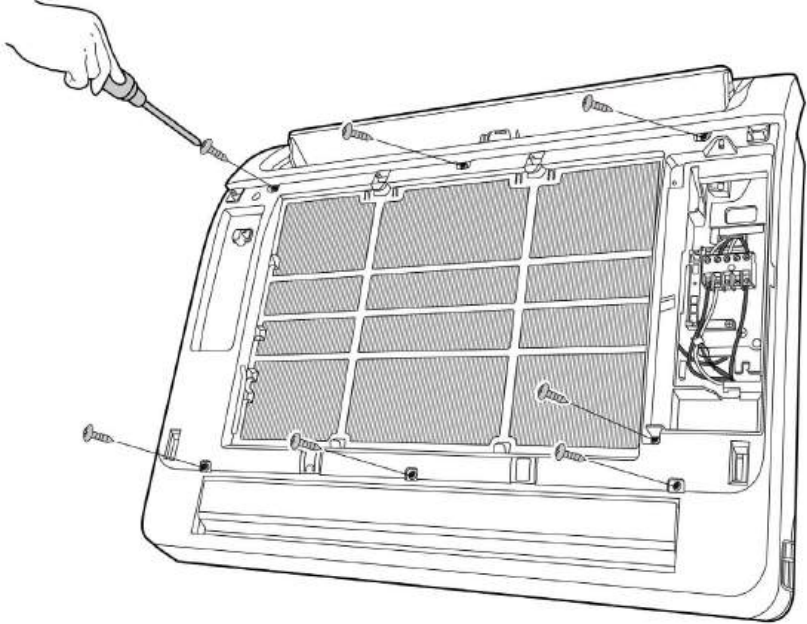
Procedure	Illustration
<p>1) Remove 7 screws and remove the panel frame subassembly(see CJ_CONSOLE2_006)</p>	 <p>CJ_CONSOLE2_006</p>

**Note:** This section is for reference only. Actual unit appearance may vary.

## 1.4 Upper Air Outlet Frame Assembly

**Note:** Remove the front panel and panel frame subassembly (refer to 1.1. Filter&1.3 Panel frame subassembly) before disassembling upper air outlet frame assembly.

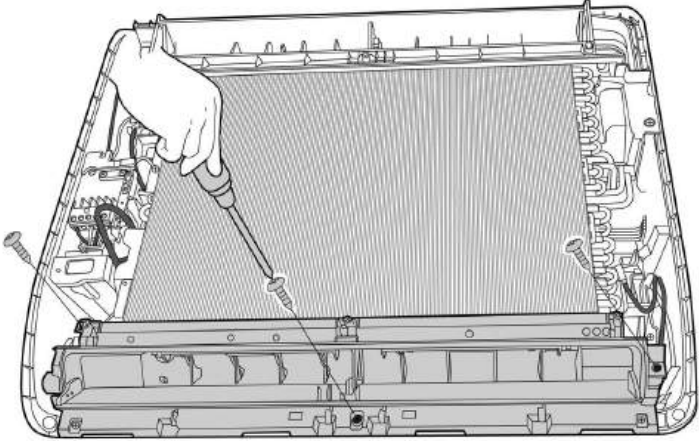
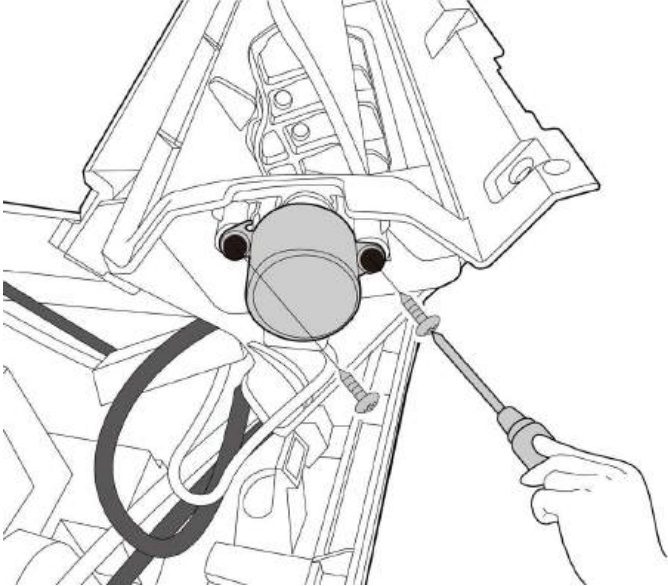
Procedure	Illustration
<p>1) Remove 3 screws and remove the upper air outlet frame assembly.(see CJ_CONSOLE2_007)</p>	 <p>CJ_CONSOLE2_007</p>
<p>2) Remove 2 screws and remove the upper the stepper motor.(see CJ_CONSOLE2_008)</p>	 <p>CJ_CONSOLE2_008</p>

**Note:** This section is for reference only. Actual unit appearance may vary.

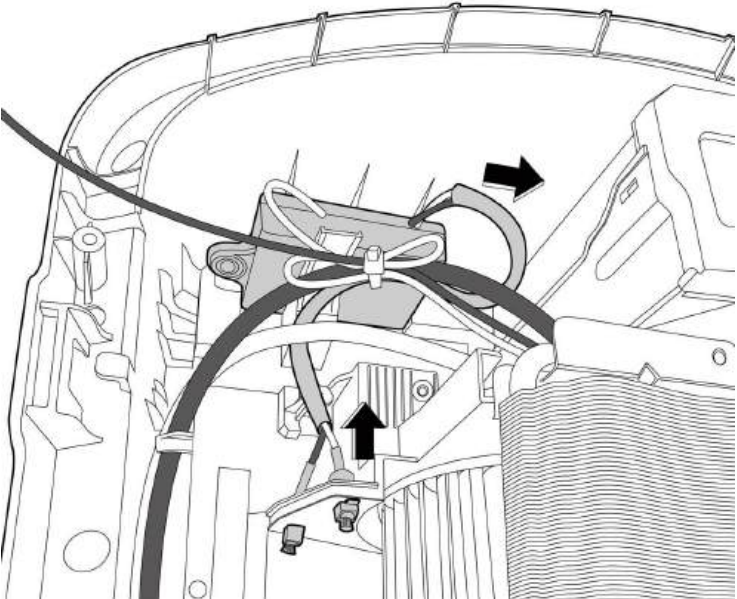
Procedure	Illustration
<p>3) Take out the positive and negative ion generator upward, and pull out the positive and negative ion emitter(see CJ_CONSOLE2_009)(for some units)</p>	 <p>CJ_CONSOLE2_009</p>

**Note:** This section is for reference only. Actual unit appearance may vary.

## 1.5 Lower Air Outlet Frame Assembly

**Note:** Remove the front panel and panel frame subassembly (refer to 1.1. Filter&1.3 Panel frame subassembly) before disassembling lower air outlet frame assembly.

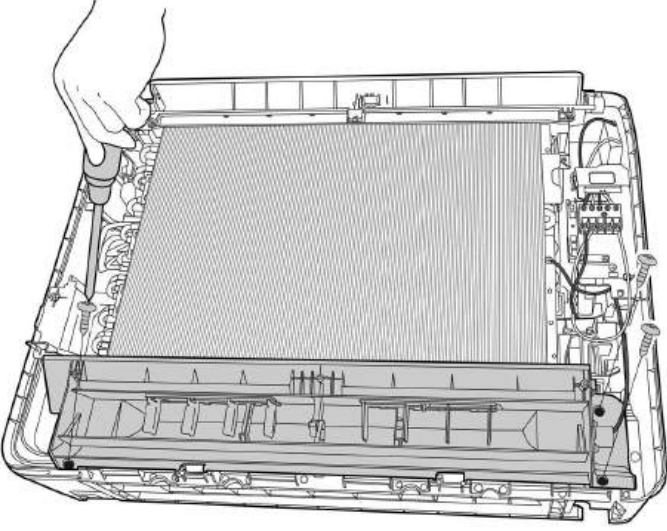
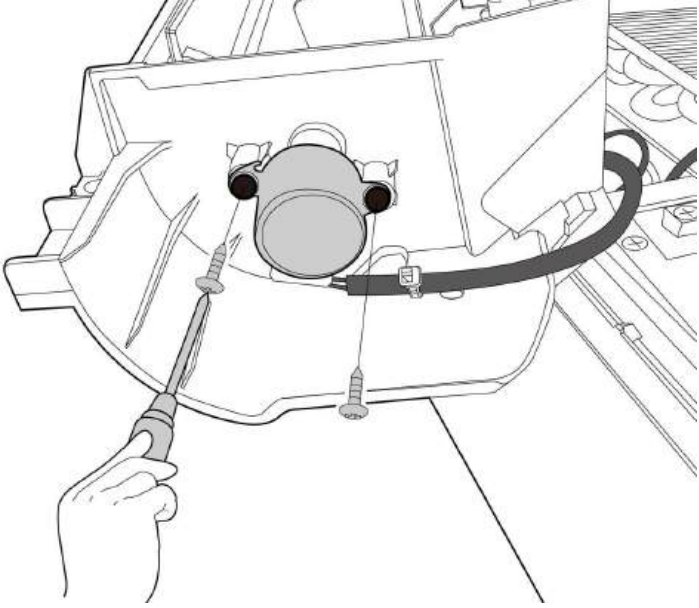
Procedure	Illustration
<p>1) Remove 3 screws and remove the lower air outlet frame assembly.(see CJ_CONSOLE2_010)</p> <p>2) Remove 2 screws and remove the lower the stepper motor.(see CJ_CONSOLE2_011)</p>	 <p data-bbox="928 1025 1177 1057">CJ_CONSOLE2_010</p>  <p data-bbox="928 1706 1177 1738">CJ_CONSOLE2_011</p>

**Note:** This section is for reference only. Actual unit appearance may vary.

## 1.6 Evaporator

**Note:** Remove the front panel, panel frame subassembly, upper air outlet frame assembly and lower air outlet frame assembly (refer to 1.1,1.3,1.4&1.5 ) before disassembling evaporator.

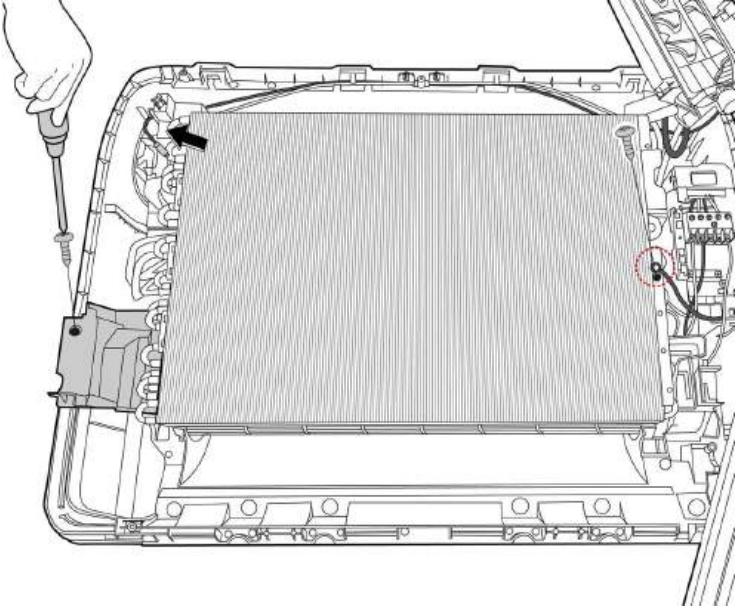
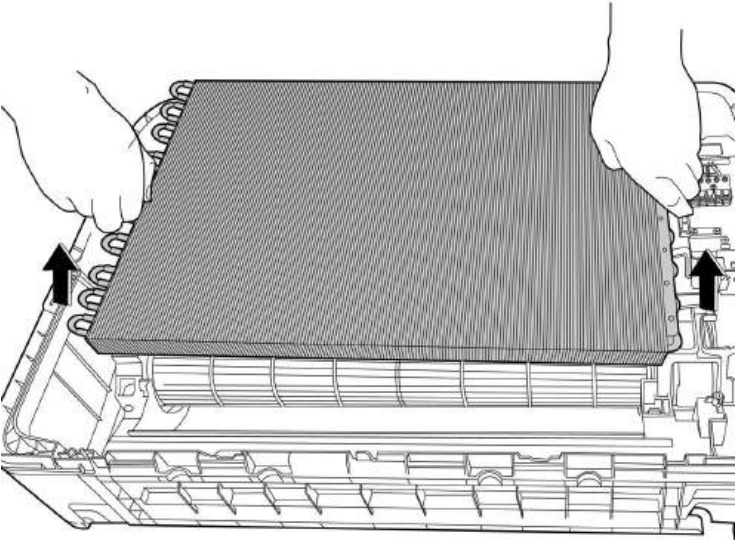
Procedure	Illustration
<p>1) Remove 1 screw and remove auxiliary water pan.(see CJ_CONSOLE2_012)</p> <p>Remove one screw used for the ground connection(see CJ_CONSOLE2_012)</p> <p>pull out the coil temperature sensor (T2) (see CJ_CONSOLE2_012)</p>	 <p style="text-align: center;"><b>CJ_CONSOLE2_012</b></p>
<p>2) Take out evaporator subassembly.(see CJ_CONSOLE2_013)</p>	 <p style="text-align: center;"><b>CJ_CONSOLE2_013</b></p>

**Note:** This section is for reference only. Actual unit appearance may vary.

## 1.7 Fan and Fan Motor

**Note:** Remove the evaporator subassembly (refer to 1.1, 1.3, 1.4, 1.5 and 1.6) before disassembling fan.

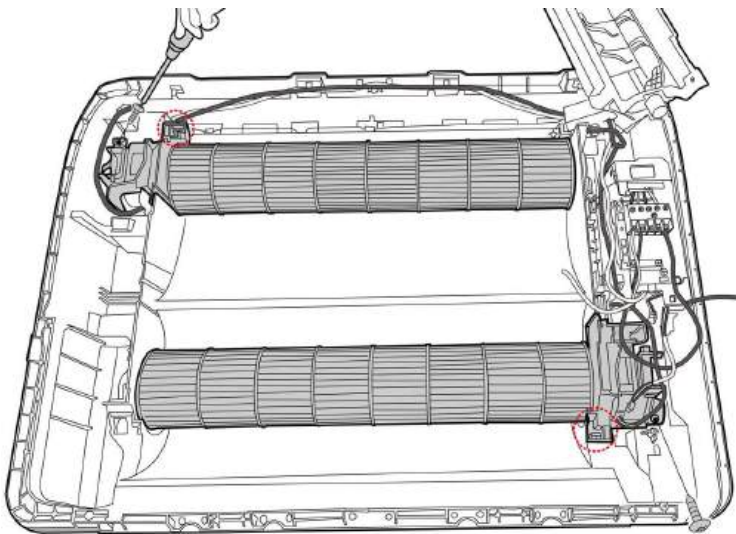
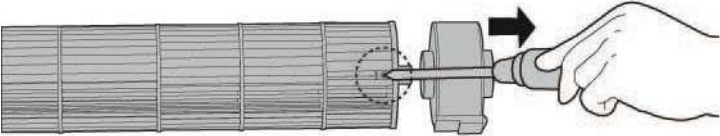
Procedure	Illustration
<p>1) Remove 1 screw and 1 hook, and remove the motor cover (there are two motor covers). (see CJ_CONSOLE2_014)</p> <p>2) Pull out the fan motor and fan assembly from the side.</p>	 <p>CJ_CONSOLE2_014</p>
<p>2) Remove the fixing screw and remove the fan motor. (see CJ_CONSOLE2_015)</p>	 <p>CJ_CONSOLE2_015</p>

**Note:** This section is for reference only. Actual unit appearance may vary.

## 1.8 Electrical Parts (Antistatic gloves must be worn.)

Note: Remove the front panel& panel frame subassembly (refer to 1.1&1.3 ) before disassembling electrical parts.

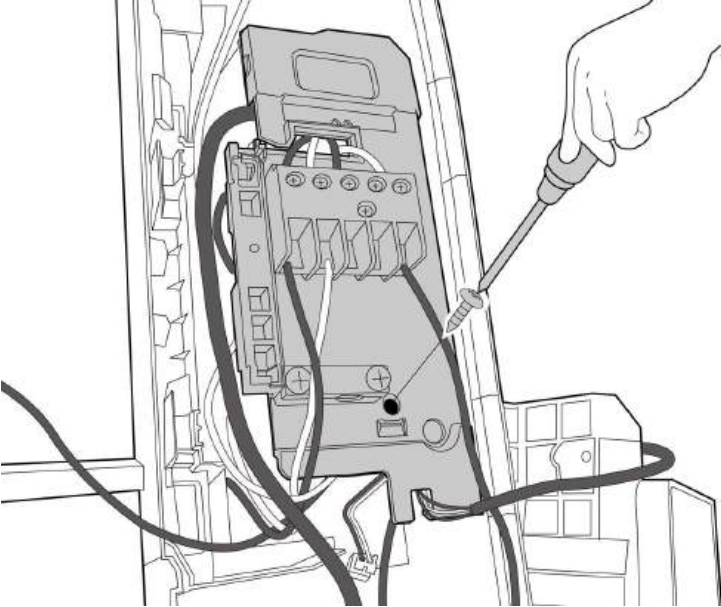
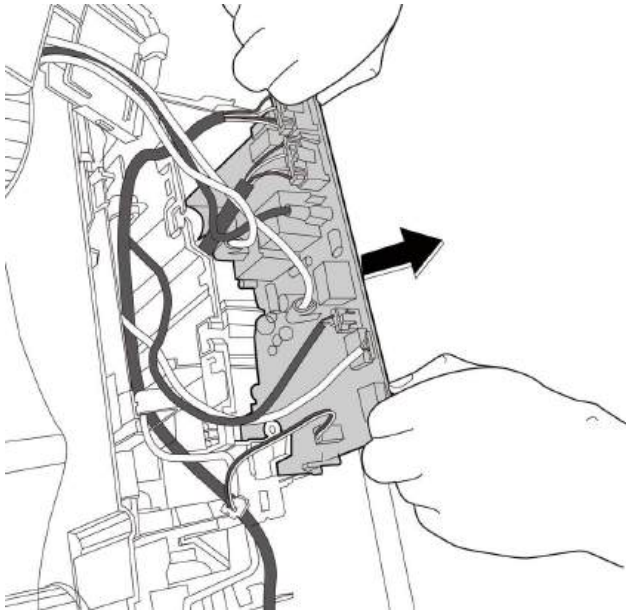
Procedure	Illustration
1) Remove 1 screw and remove the cover of electronic control box. (see CJ_CONSOLE2_016)	 <p>CJ_CONSOLE2_016</p>
2) Pull out the electrical main board. (see CJ_CONSOLE2_017)	 <p>CJ_CONSOLE2_017</p>

Note: This section is for reference only. Actual unit appearance may vary.

---

# Outdoor Unit Disassembly

## Contents

<b>1.</b>	<b>Outdoor Unit Table</b> .....	<b>2</b>
<b>2.</b>	<b>Outdoor Unit Disassembly</b> .....	<b>3</b>
2.1	Panel Plate.....	3
2.2	Electrical Parts .....	16
2.3	Fan Assembly .....	41
2.4	Fan Motor .....	42
2.5	Sound Blanket.....	43
2.6	Four-way Valve .....	44
2.7	Compressor.....	45



---

## 1. Outdoor Unit Disassembly

### 1.1 Outdoor Unit Table

Outdoor Unit Model	Panel Plate	PCB Board
MOX230-12HFN1-MV5W	X230	PCB Board 11
MOX330-12HFN1-MW5W	X330	PCB Board 11
MOX430-18HFN1-MU0W	X430	PCB Board 3
MOX430-17HFN1-MT0W	X430	PCB Board 3

## 2. Outdoor Unit Disassembly

### 2.1 Panel Plate

#### 1. X230/X330

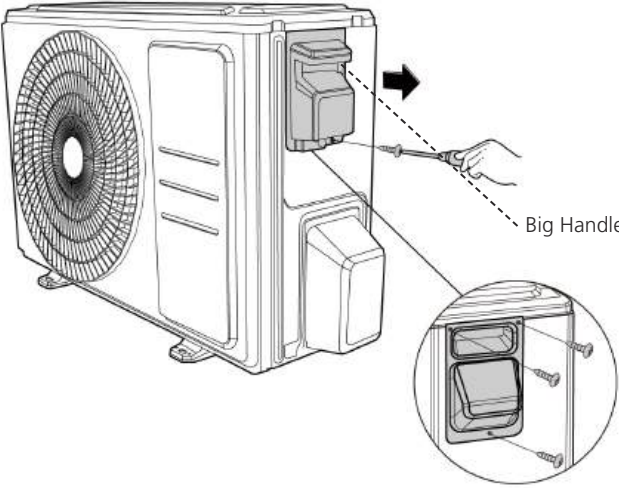
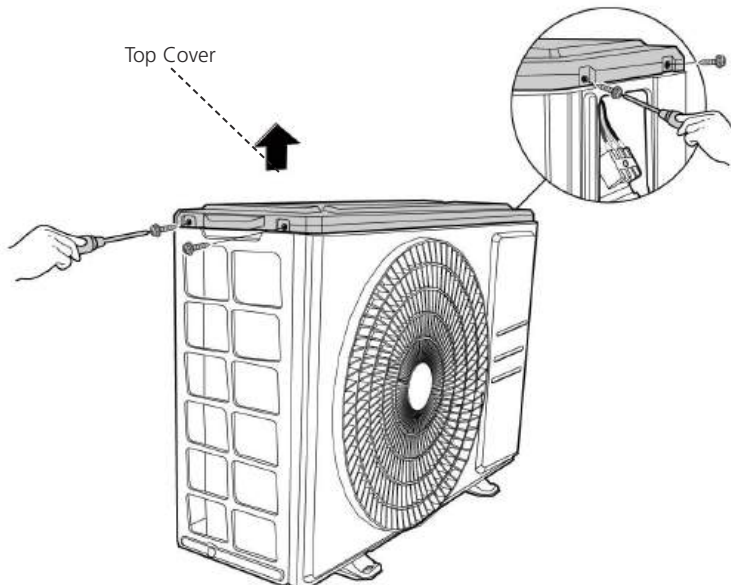
Procedure	Illustration
<p>1) Turn off the air conditioner and the power breaker.</p> <p>2) Remove the screw of the big handle and then remove the big handle (1 screws) (see CJ_X230_001).</p>	 <p style="text-align: center;">CJ_X230_001</p>
<p>3) Remove the screws of the top cover and then remove the top cover (4 screws). One of the screws is located underneath the big handle (see CJ_X230_002).</p>	 <p style="text-align: center;">CJ_X230_002</p>

**Note:** This section is for reference only. Actual unit appearance may vary.

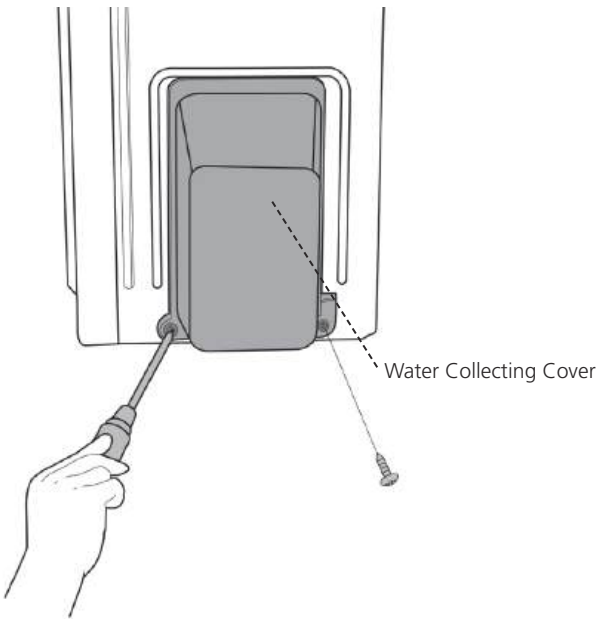
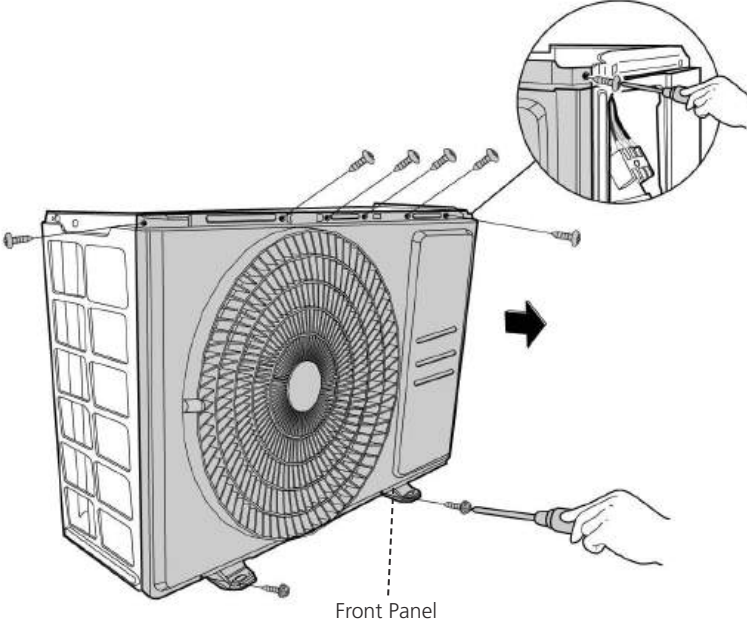
Procedure	Illustration
<p>4) Remove the screws of water collecting cover and then remove the water collecting cover (2 screws) (see CJ_X230_003).</p>	 <p style="text-align: center;"><b>CJ_X230_003</b></p>
<p>5) Remove the screws of the front panel and then remove the front panel (7 screws(onoff models) or 9 screws(inverter models) (see CJ_X230_004).</p>	 <p style="text-align: center;"><b>CJ_X230_004</b></p>

**Note:** This section is for reference only. Actual unit appearance may vary.

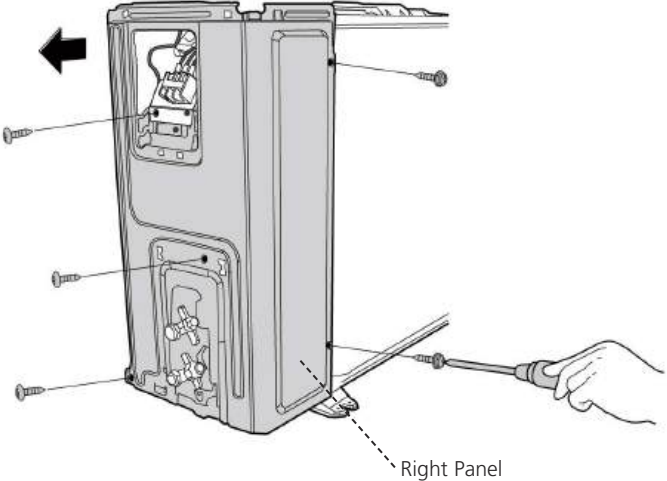
Procedure	Illustration
<p>6) Remove the screws of the right panel and then remove the right panel (5 screws) (see CJ_X230_005).</p>	 <p data-bbox="1098 869 1203 896">Right Panel</p> <p data-bbox="932 927 1101 958">CJ_X230_005</p>

Note: This section is for reference only. Actual unit appearance may vary.

## 2.X430

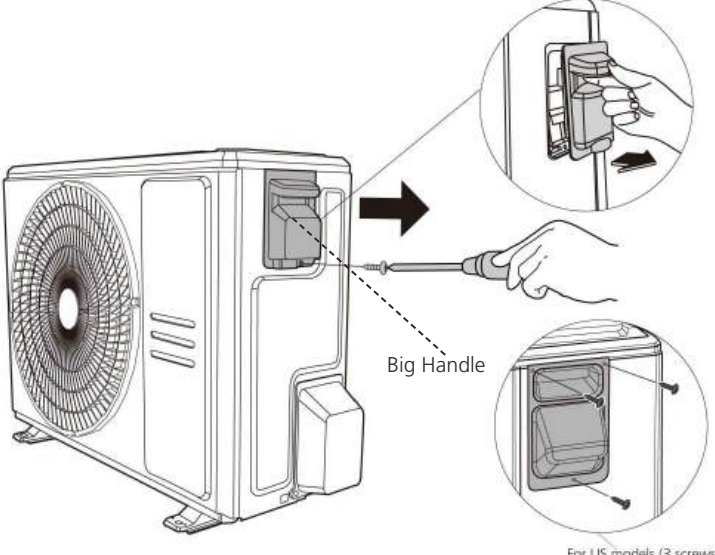
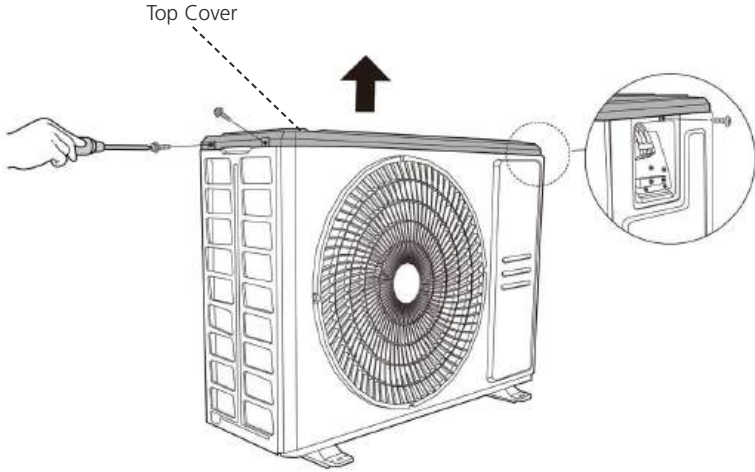
Procedure	Illustration
<p>1) Turn off the air conditioner and the power breaker.</p> <p>2) Remove the screw of the big handle and then remove the big handle (1 screw) (see CJ_X430_001).</p>	 <p>Big Handle</p> <p>For US models (3 screws)</p> <p><b>CJ_X430_001</b></p>
<p>3) Remove the screws of the top cover and then remove the top cover (3 screws). One of the screws is located underneath the big handle (see CJ_X430_002).</p>	 <p>Top Cover</p> <p><b>CJ_X430_002</b></p>

**Note:** This section is for reference only. Actual unit appearance may vary.

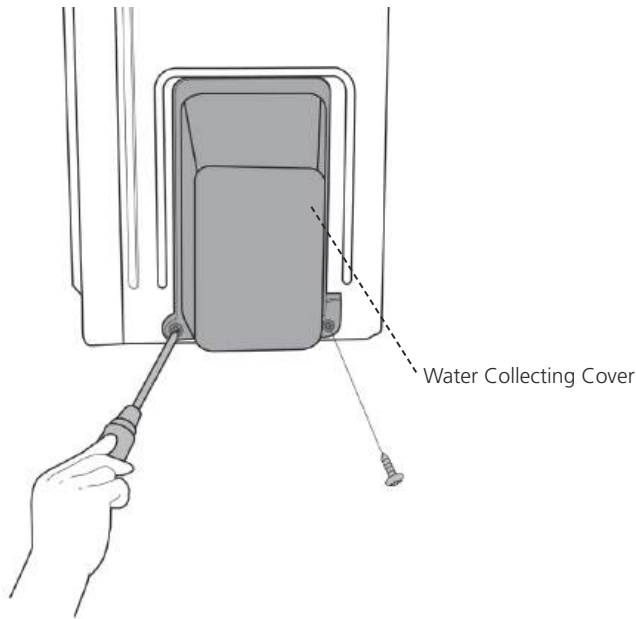
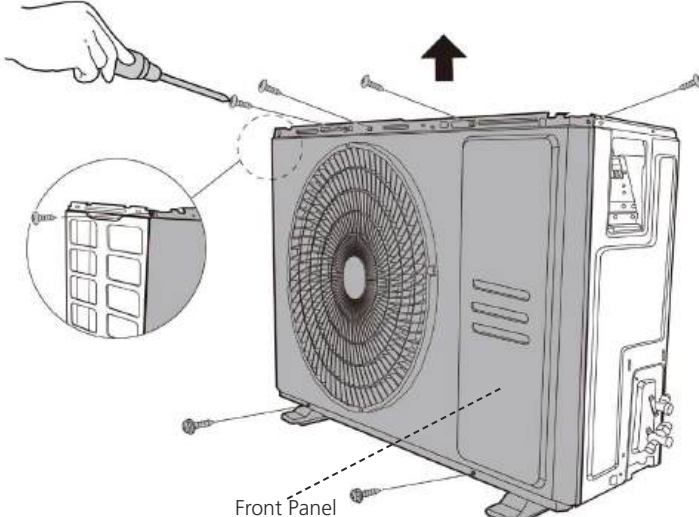
Procedure	Illustration
<p>4) Remove the screws of water collecting cover and then remove the water collecting cover (2 screws) (see CJ_X430_003).</p>	 <p style="text-align: center;"><b>CJ_X430_003</b></p>
<p>5) Remove the screws of the front panel and then remove the front panel (7 screws(onoff models) or 9 screws(inverter models) (see CJ_X430_004).</p>	 <p style="text-align: center;"><b>CJ_X430_004</b></p>

**Note:** This section is for reference only. Actual unit appearance may vary.

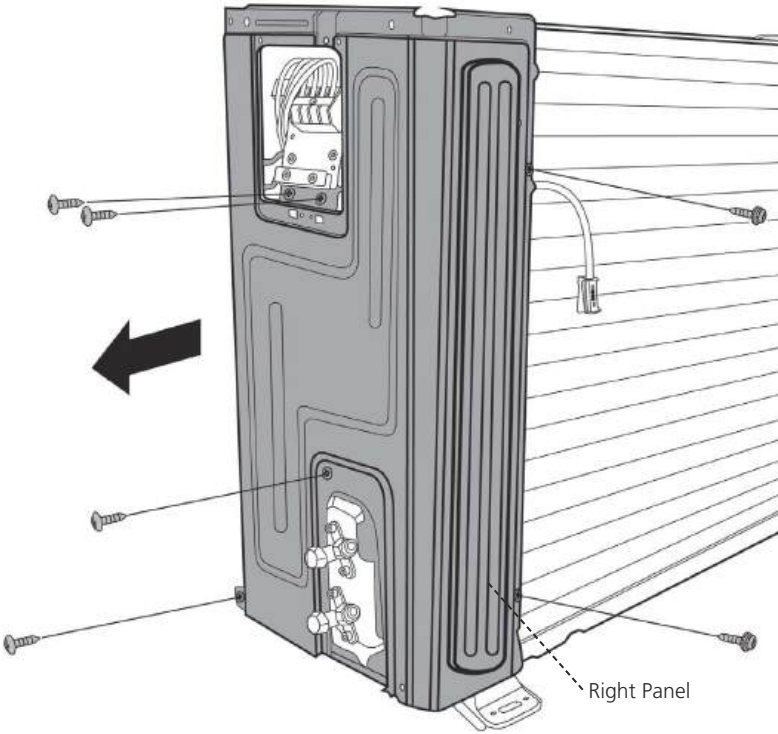
Procedure	Illustration
<p>6) Remove the screws of the right panel and then remove the right panel (6 screws) (see CJ_X430_005).</p>	 <p data-bbox="932 1160 1102 1191">CJ_X430_005</p>

Note: This section is for reference only. Actual unit appearance may vary.

### 3. D30

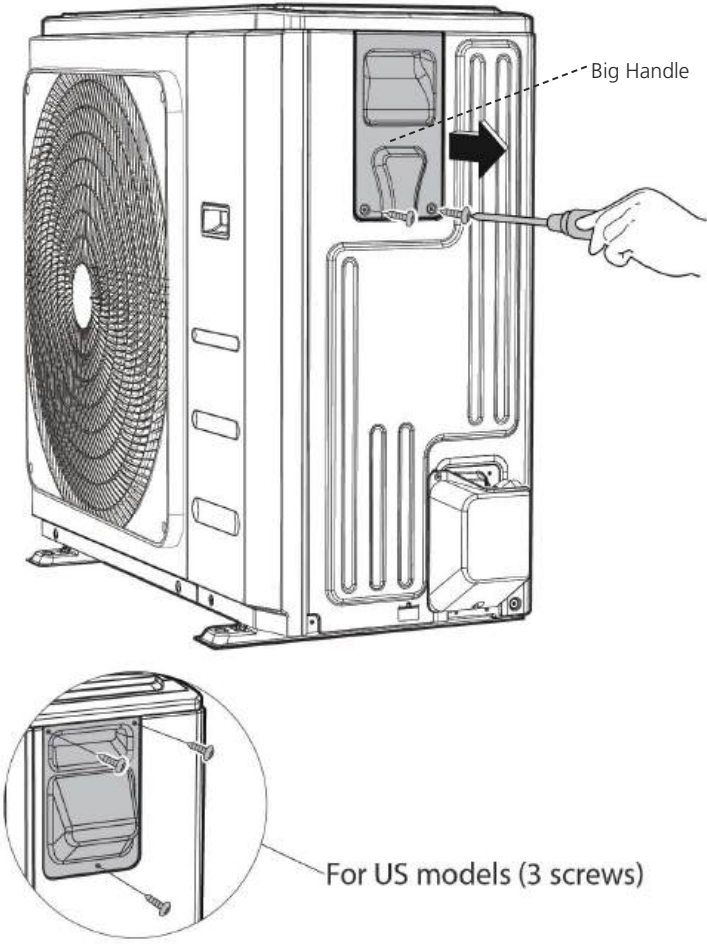
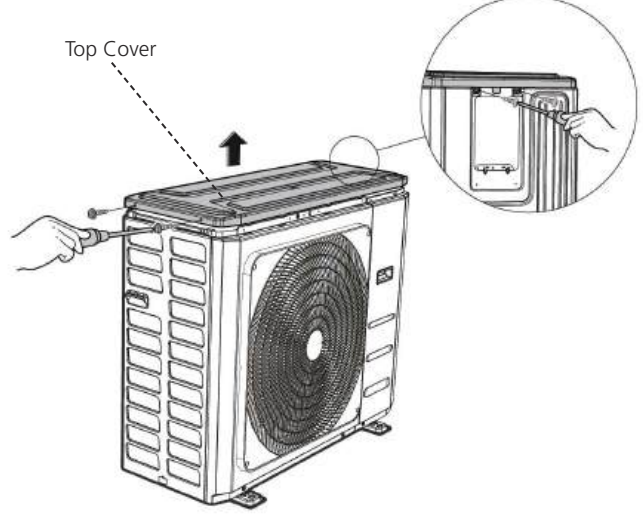
Procedure	Illustration
<p>1) Turn off the air conditioner and the power breaker.</p> <p>2) Remove the screws of the big handle and then remove the big handle (2 screws) (see CJ_D30_001).</p>	 <p>CJ_D30_001</p>
<p>3) Remove the screws of the top cover and then remove the top cover (4 screws). Two of the screws is located underneath the big handle (see CJ_D30_002).</p>	 <p>CJ_D30_002</p>

**Note:** This section is for reference only. Actual unit appearance may vary.

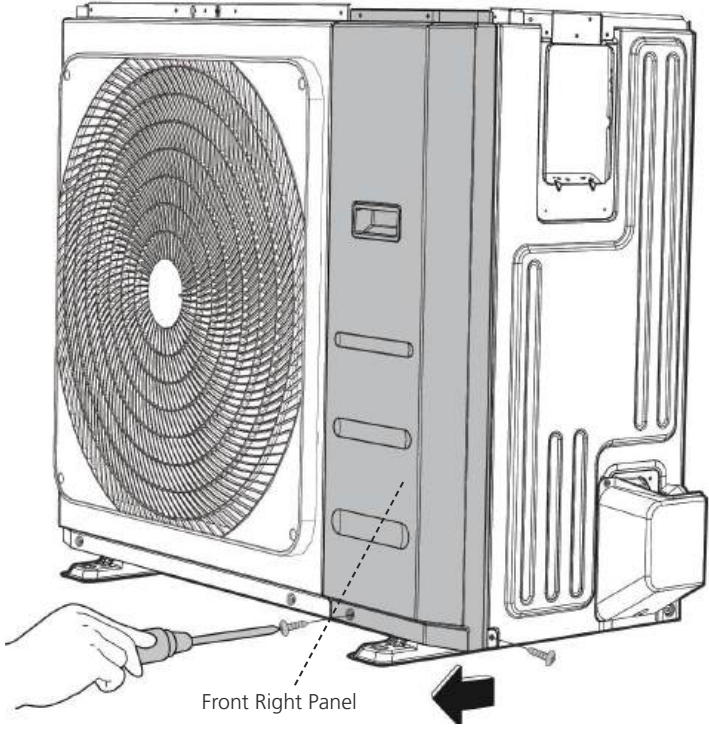
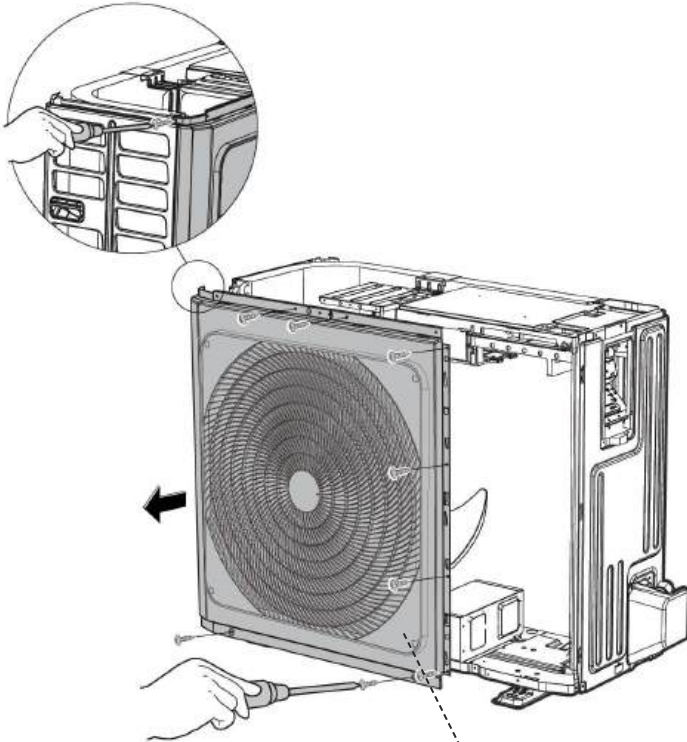

Procedure	Illustration
<p>4) Remove the screws of the front right panel and then remove the front right panel (2 screws) (see CJ_D30_003).</p>	 <p style="text-align: center;">Front Right Panel</p> <p style="text-align: center;"><b>CJ_D30_003</b></p>
<p>5) Remove the screws of the front panel and then remove the front panel (9 screws) (see CJ_D30_004).</p>	 <p style="text-align: center;">Front Panel</p> <p style="text-align: center;"><b>CJ_D30_004</b></p>

**Note:** This section is for reference only. Actual unit appearance may vary.

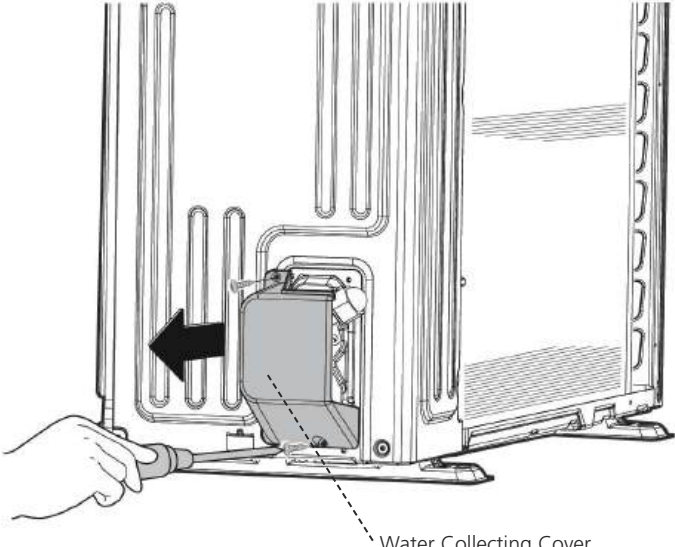
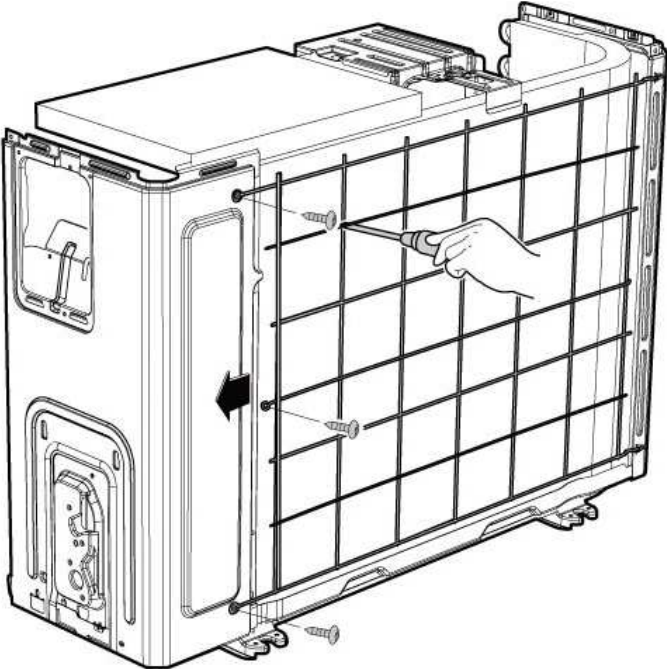
Procedure	Illustration
<p>6) Remove the screws of water collecting cover and then remove the water collecting cover (2 screws) (see CJ_D30_005).</p>	 <p style="text-align: right;">Water Collecting Cover</p> <p style="text-align: center;"><b>CJ_D30_005</b></p>
<p>7) Remove the screws of the rear net and then remove the rear net (2 screws) (see CJ_D30_006). (for some models)</p>	 <p style="text-align: center;"><b>CJ_D30_006</b></p>

**Note:** This section is for reference only. Actual unit appearance may vary.

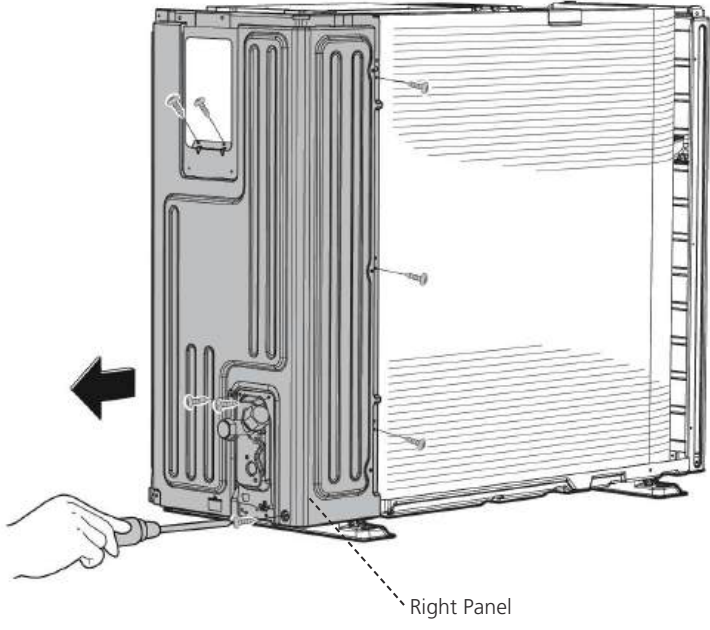
Procedure	Illustration
<p>8) Remove the screws of the right panel and then remove the right panel (8 screws) (see CJ_D30_007).</p>	 <p>Right Panel</p> <p>CJ_D30_007</p>

Note: This section is for reference only. Actual unit appearance may vary.

#### 4. E30/590

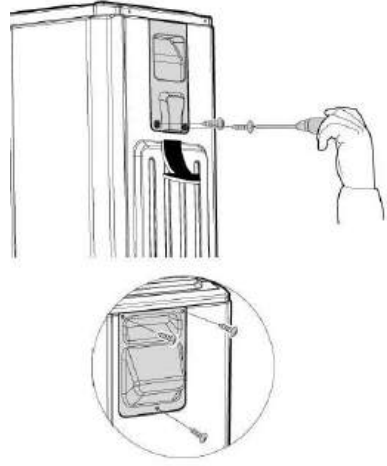
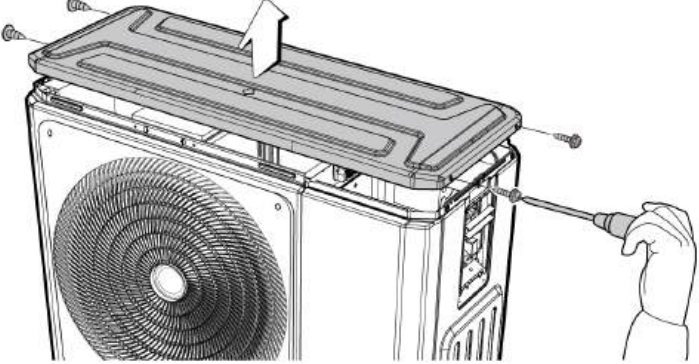
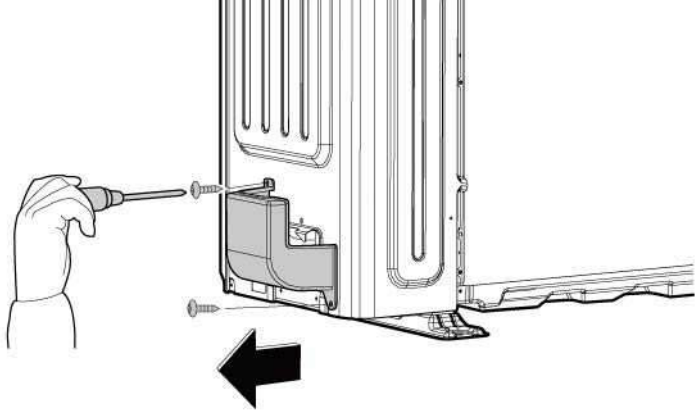
Procedure	Illustration
<p>1) Turn off the air conditioner and the power breaker.</p> <p>2) Remove the screws of the big handle and then remove the big handle (2 screws) (see CJ_E30_001).</p>	 <p>CJ_E30_001</p>
<p>3) Remove the screws of the top cover and then remove the top cover (4 screws). Two of the screws is located underneath the big handle (see CJ_E30_002).</p>	 <p>CJ_E30_002</p>
<p>4) Remove the screws of water collecting cover and then remove the water collecting cover (2 screw) (see CJ_E30_003).</p>	 <p>CJ_E30_003</p>

**Note:** This section is for reference only. Actual unit appearance may vary.

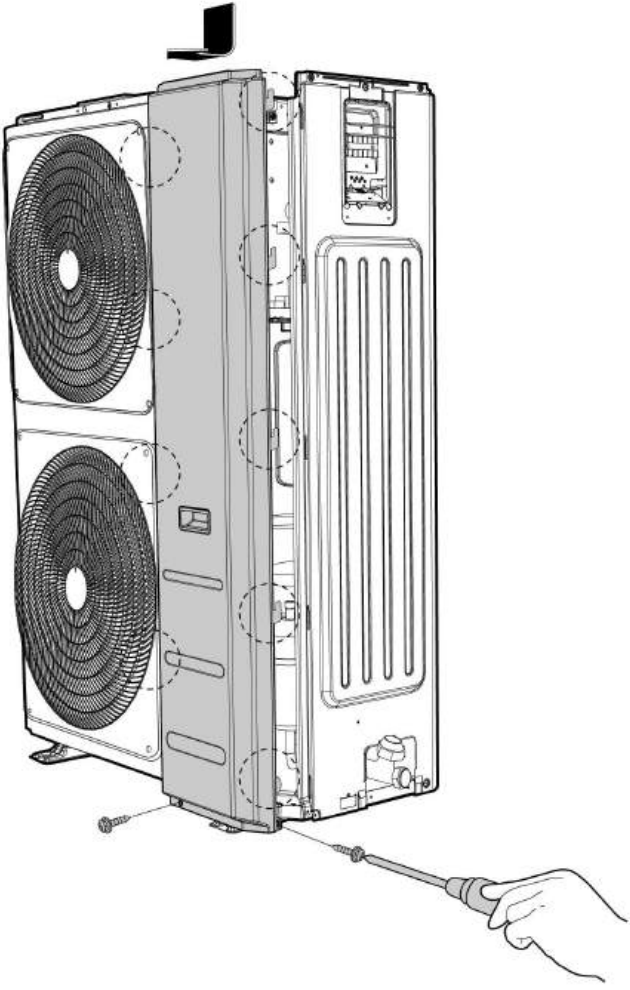
Procedure	Illustration
<p>5) Remove the screws of the front right panel and then remove the front right panel (2 screws) (see CJ_E30_004).</p>	 <p>CJ_E30_004</p>

Note: This section is for reference only. Actual unit appearance may vary.

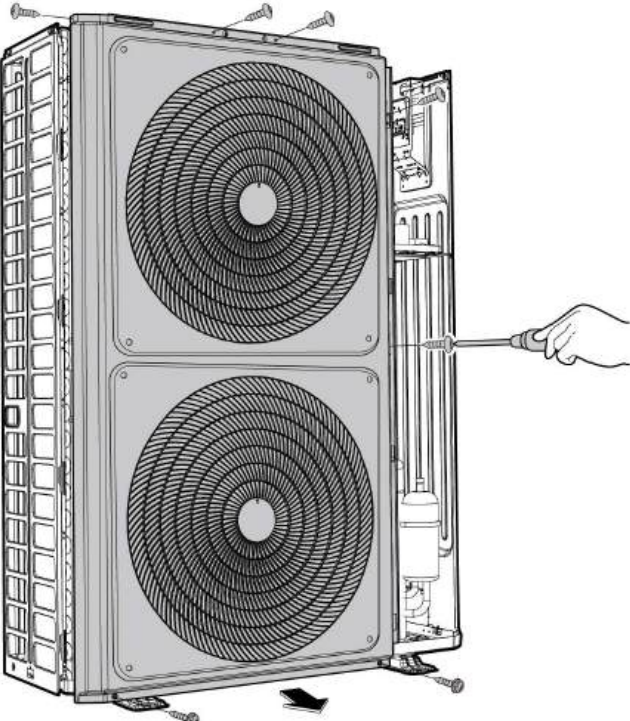
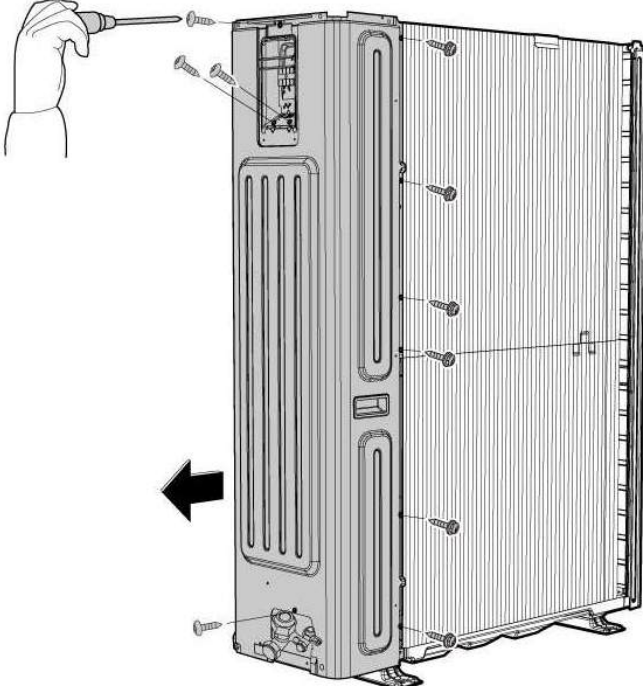
Procedure	Illustration
<p>1) Remove the screws of the front panel and then remove the front panel (7 screws) (see CJ_E30_005).</p>	 <p style="text-align: center;">CJ_E30_005</p>
<p>2) Remove the screws of the right panel and then remove the right panel (10 screws) (see CJ_E30_006).</p>	 <p style="text-align: center;">CJ_E30_006</p>

**Note:** This section is for reference only. Actual unit appearance may vary.

## 2.2 Electrical parts

**⚠ WARNING:** Antistatic gloves must be worn when you disassemble the electronic box.

**Note:** Remove the air outlet grille(refer to 3.1 Panel Plate) before disassembling electrical parts.

### 1. PCB board 1

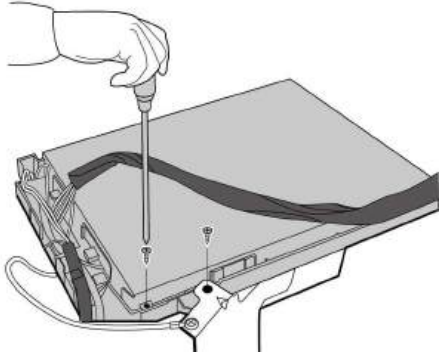
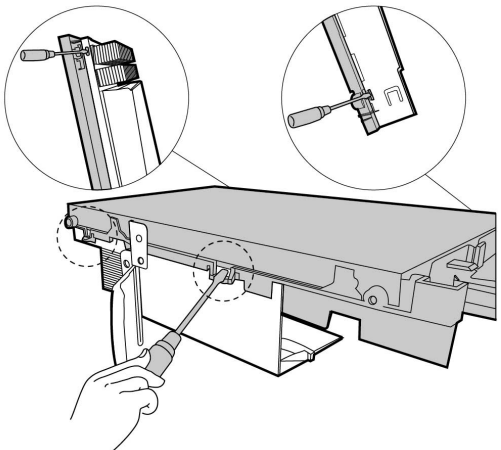
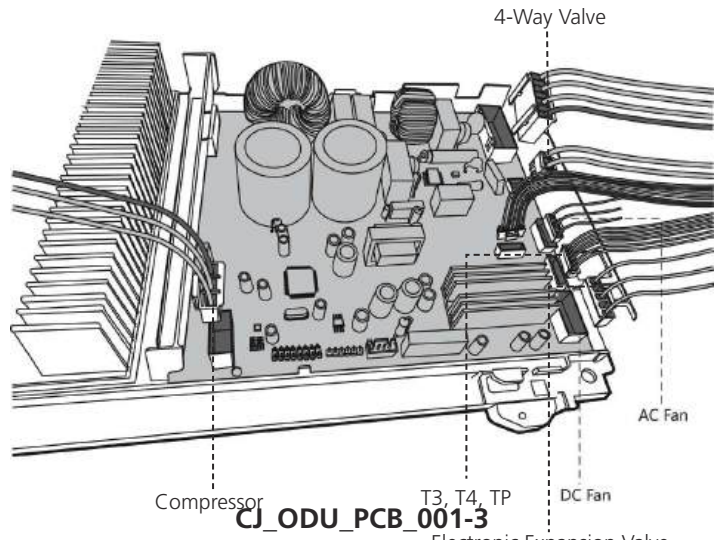
Procedure	Illustration
<p>1) Remove the screws of the top cover. (2 screws) (see CJ_ODU_PCB_001-1).</p>	 <p style="text-align: center;"><b>CJ_ODU_PCB_001-1</b></p>
<p>2) Unfix the hooks and then open the electronic control box cover (4 hooks) (see CJ_ODU_PCB_001-2).</p>	 <p style="text-align: center;"><b>CJ_ODU_PCB_001-2</b></p>
<p>3) Disconnect the connector for fan motor from the electronic control board (see CJ_ODU_PCB_001-3).</p> <p>4) Remove the connector for the compressor (see CJ_ODU_PCB_001-3).</p> <p>5) Pull out the two blue wires connected with the four way valve (CJ_ODU_PCB_001-3).</p> <p>6) Pull out connectors of the condenser coil temp. sensor(T3), outdoor ambient temp. sensor(T4) and discharge temp. sensor(TP) (CJ_ODU_PCB_001-3).</p> <p>7) Disconnect the electronic expansion valve wire (CJ_ODU_PCB_001-3).</p> <p>8) Then remove the electronic control board.</p>	 <p style="text-align: center;"><b>CJ_ODU_PCB_001-3</b></p>

**Note:** This section is for reference only. Actual unit appearance may vary.

## 2. PCB board 2

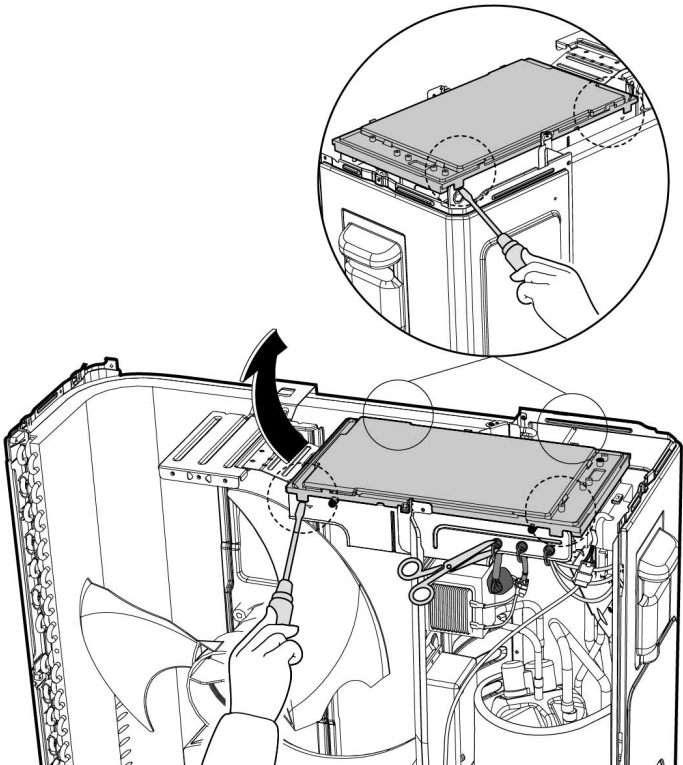
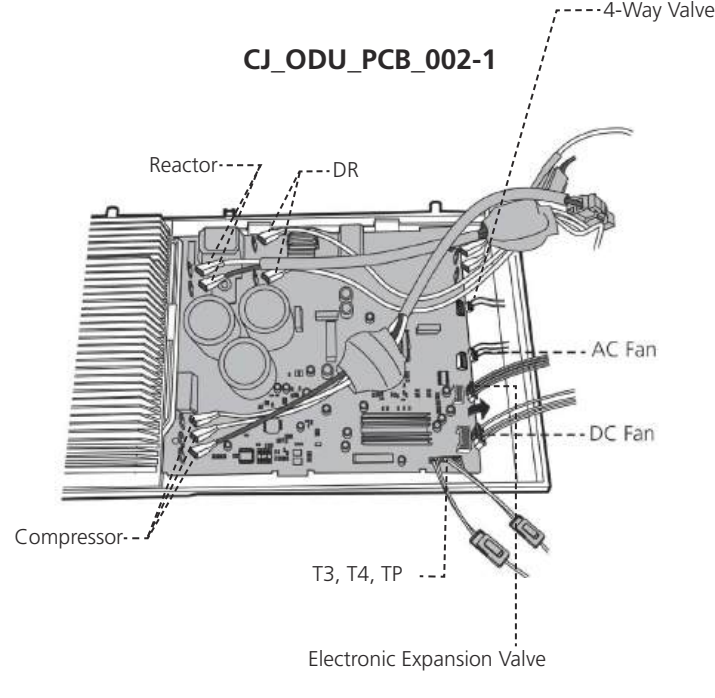
Procedure	Illustration
<p>1) Unfix the hooks and then open the electronic control box cover (4 hooks) (see CJ_ODU_PCB_002-1).</p>	
<p>2) Disconnect the connector for fan motor from the electronic control board (see CJ_ODU_PCB_002-2).</p> <p>3) Remove the connector for the compressor (see CJ_ODU_PCB_002-2).</p> <p>4) Pull out the two blue wires connected with the four way valve (see CJ_ODU_PCB_002-2).</p> <p>5) Pull out connectors of the condenser coil temp. sensor(T3), outdoor ambient temp. sensor(T4) and discharge temp. sensor(TP) (see CJ_ODU_PCB_002-2).</p> <p>6) Disconnect the electronic expansion valve wire (see Fig CJ_ODU_PCB_002-2).</p> <p>7) Then remove the electronic control board.</p>	 <p style="text-align: center;"><b>CJ_ODU_PCB_002-1</b></p> <p style="text-align: center;"><b>CJ_ODU_PCB_002-2</b></p>

**Note:** This section is for reference only. Actual unit appearance may vary.

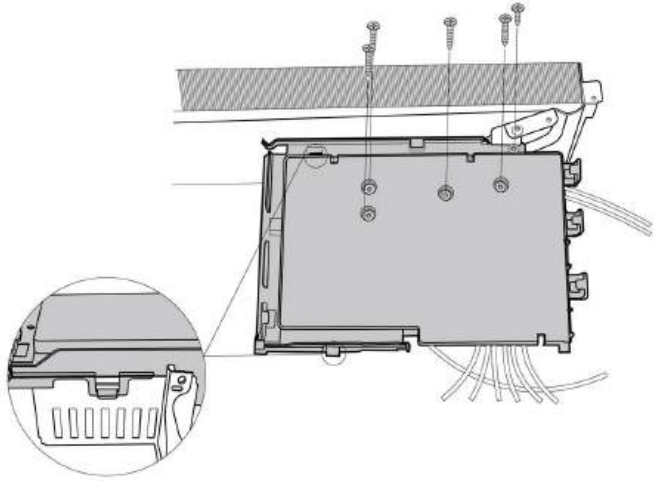
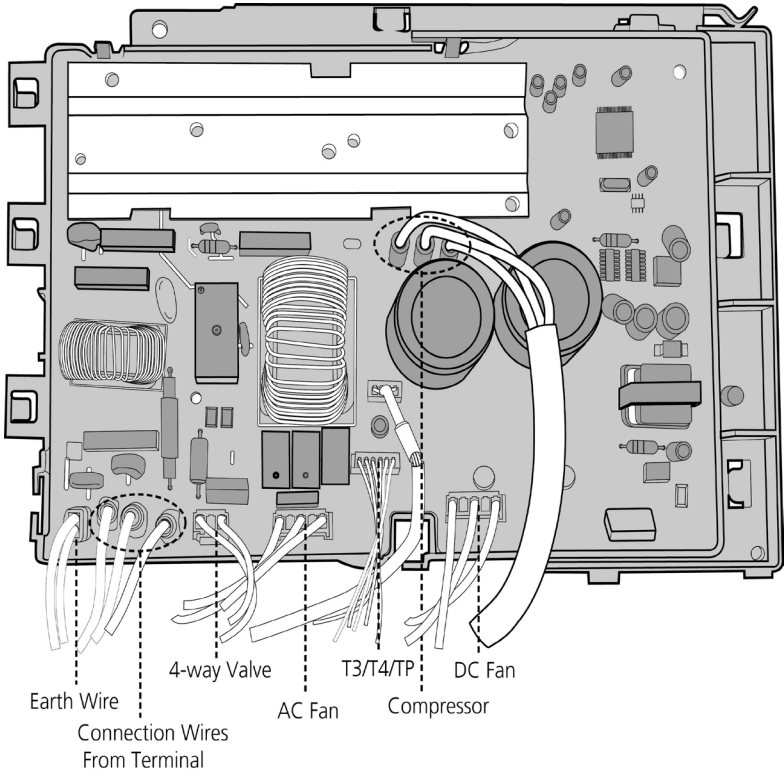

### 3. PCB board 3

Procedure	Illustration
<p>1) Remove the screws and unfix the hooks, then open the electronic control box cover (5 screws and 2 hooks)(see CJ_ODU_PCB_003-1).</p> <p>Note: Electric control box cover cannot be removed, so the voltage between P and N cannot be measured.</p>	 <p style="text-align: center;"><b>CJ_ODU_PCB_003-1</b></p>
<p>2) Remove all of connectors (see Fig CJ_ODU_PCB_003-2).</p> <p>3) Then remove the electronic control box subassembly.</p> <p>Note: When replacing the electronic control box subassembly with a new one, pay attention to applying thermal paste on the heat sink.</p>	 <p style="text-align: center;"><b>CJ_ODU_PCB_003-2</b></p>

**Note:** This section is for reference only. Actual unit appearance may vary.

#### 4. PCB board 4

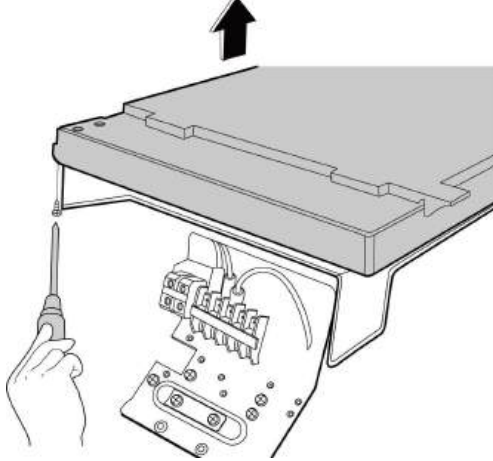
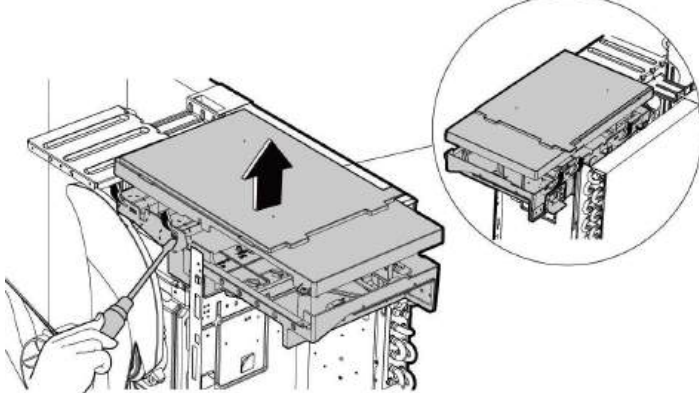
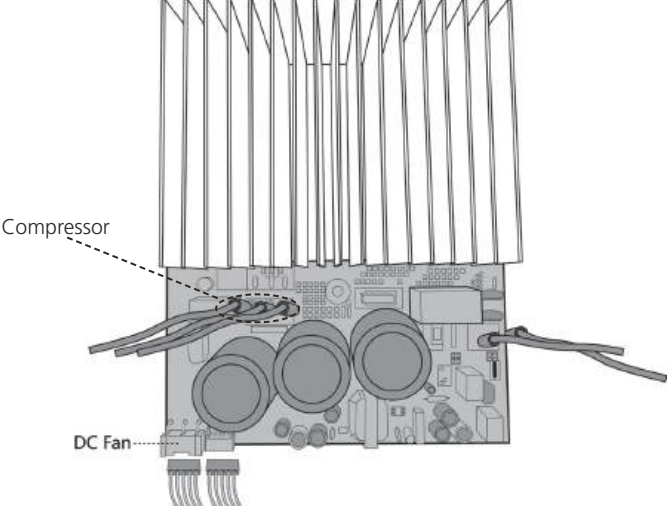
Procedure	Illustration
1) Remove the screws of the top cover. (1 screws) (see CJ_ODU_PCB_004-1).	 <p style="text-align: center;"><b>CJ_ODU_PCB_004-1</b></p>
2) Unfix the hooks and then open the electronic control box cover (5 hooks) (see CJ_ODU_PCB_004-2).	 <p style="text-align: center;"><b>CJ_ODU_PCB_004-2</b></p>
3) Disconnect the connector for fan motor from the IPM board (see CJ_ODU_PCB_004-3). 4) Remove the connector for the compressor (see CJ_ODU_PCB_004-3).	 <p style="text-align: center;"><b>CJ_ODU_PCB_004-3</b></p>

**Note:** This section is for reference only. Actual unit appearance may vary.

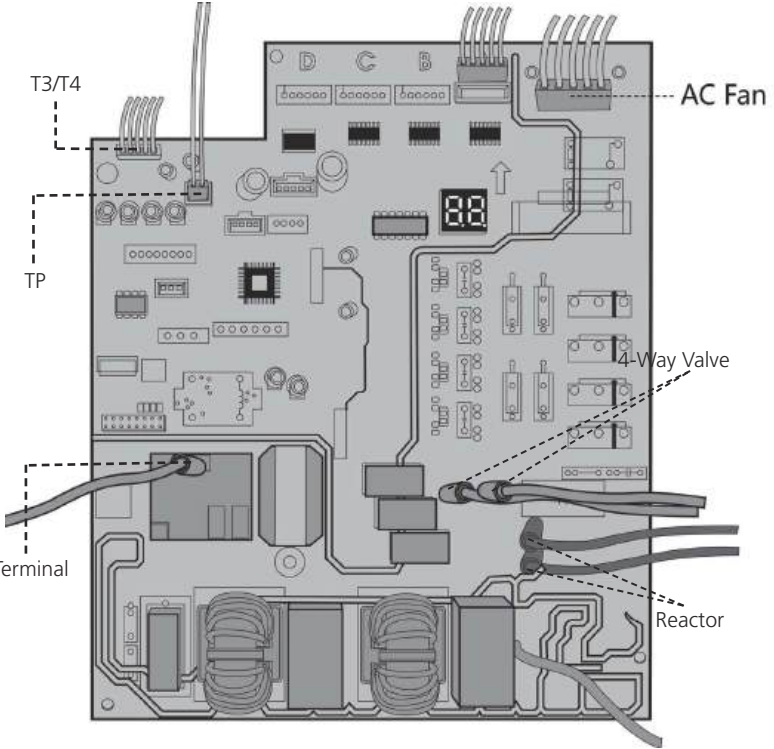
Procedure	Illustration
<p>5) Pull out the wire connected with the terminal. (see CJ_ODU_PCB_004-4).</p> <p>6) Pull out connectors of the condenser coil temp. sensor(T3),outdoor ambient temp. sensor(T4) and discharge temp. sensor(TP) (see CJ_ODU_PCB_004-4).</p> <p>7) Disconnect the electronic expansion valve wire (see Fig CJ_ODU_PCB_004-4).</p> <p>8) Remove the connector for 4-way valve. (see Fig CJ_ODU_PCB_004-4).</p> <p>9) Remove the connector for the reactor (see Fig CJ_ODU_PCB_004-4).</p> <p>10)Then remove the electronic control box (see Fig CJ_ODU_PCB_004-4).</p>	 <p style="text-align: center;"><b>CJ_ODU_PCB_004-4</b></p>

**Note:** This section is for reference only. Actual unit appearance may vary.

## 5. PCB board 5

Procedure	Illustration
<ol style="list-style-type: none"> <li>1) Unfix the hooks and then open the electronic control box cover (4 hooks) (see CJ_ODU_PCB_005-1).</li> <li>2) Disconnect the connector for outdoor DC fan from the electronic control board (see CJ_ODU_PCB_005-2).</li> <li>3) Remove the connector for the compressor (see CJ_ODU_PCB_005-2).</li> <li>4) Pull out the two blue wires connected with the four way valve (see CJ_ODU_PCB_005-2).</li> <li>5) Pull out connectors of the condenser coil temp. sensor(T3), outdoor ambient temp. sensor(T4) and discharge temp. sensor(TP) (see CJ_ODU_PCB_005-2).</li> <li>6) Disconnect the electronic expansion valve wire (see Fig CJ_ODU_PCB_005-2).</li> <li>7) Disconnect the communication wire indoor PCB (see Fig CJ_ODU_PCB_005-2).</li> <li>8) Disconnect the PFC inductor (see Fig CJ_ODU_PCB_005-2).</li> <li>9) Then remove the electronic control box (see CJ_ODU_PCB_005-2).</li> </ol>	<p style="text-align: center;"><b>CJ_ODU_PCB_005-1</b></p> <p style="text-align: center;"><b>CJ_ODU_PCB_005-2</b></p>

**Note:** This section is for reference only. Actual unit appearance may vary.

## 6. PCB board 6

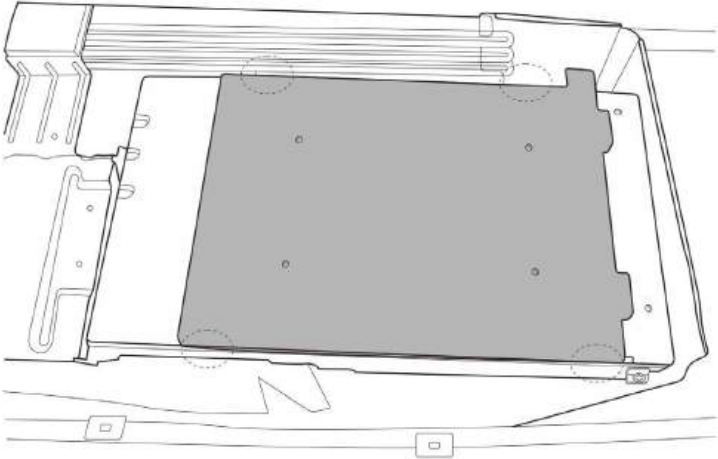
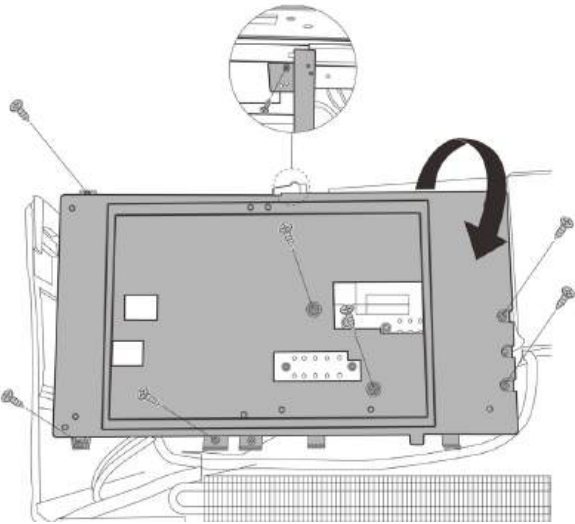
Procedure	Illustration
<p>1) Unfix the hooks and then open the electronic control box cover (4 hooks) (see CJ_ODU_PCB_006-1).</p> <p>2) Remove 8 screws on the electronic control board and then turn over the electronic control board (see CJ_ODU_PCB_006-2).</p> <p>Note: Electric control box cover cannot be removed, so the voltage between P and N cannot be measured.</p>	 <p style="text-align: center;"><b>CJ_ODU_PCB_006-1</b></p>  <p style="text-align: center;"><b>CJ_ODU_PCB_006-2</b></p>

Note: This section is for reference only. Actual unit appearance may vary.

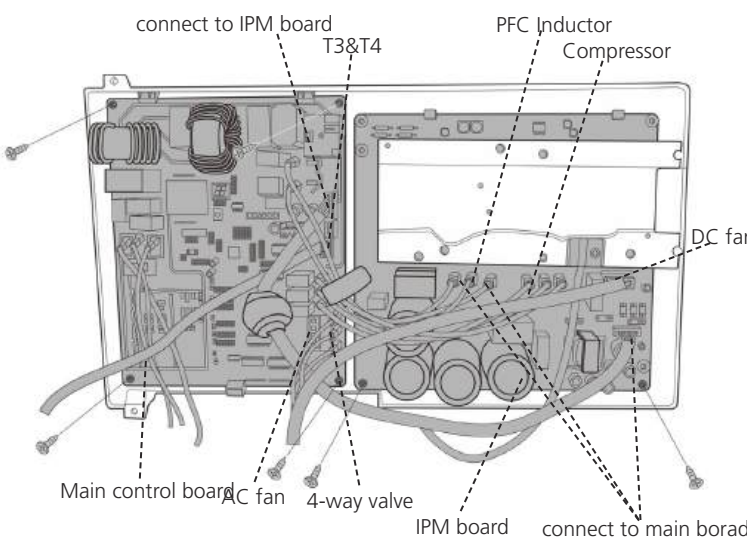
Procedure	Illustration
<p>3) Pull out the two blue wires connected with the four way valve. (see CJ_ODU_PCB_006-3)(for heat pump models)</p> <p>4) Pull out connectors of the condenser coil temp. sensor(T3),outdoor ambient temp. sensor(T4) and discharge temp. sensor(TP). (see CJ_ODU_PCB_006-3)</p> <p>5) Disconnect the electronic expansion valve wire. (see Fig CJ_ODU_PCB_006-3)(for some models)</p> <p>6) Remove four screws and unfix the 3 hooks and then remove the main control board. (see CJ_ODU_PCB_006-3)</p> <p>7) Disconnect the connector for outdoor DC fan from the IPM board. (see CJ_ODU_PCB_006-3)(for some models)</p> <p>8) Remove the connector for the compressor. (see CJ_ODU_PCB_006-3)</p> <p>9) Remove the connector for the PFC Inductor. (see CJ_ODU_PCB_006-3)</p> <p>10)Pull out 3 connectors between IPM board and main control board.(see CJ_ODU_PCB_006-3)</p> <p>11)Remove two screws and unfix the 4 hooks and then remove the IPM board. (see CJ_ODU_PCB_006-3)</p> <p>Note: When replacing the IPM board with a new one, pay attention to applying thermal paste on the heat sink.</p>	 <p style="text-align: center;"><b>CJ_ODU_PCB_006-3</b></p>

**Note:** This section is for reference only. Actual unit appearance may vary.

## 7. PCB board 7

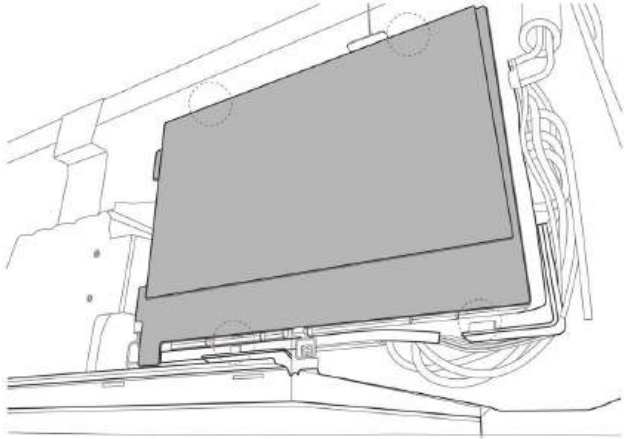
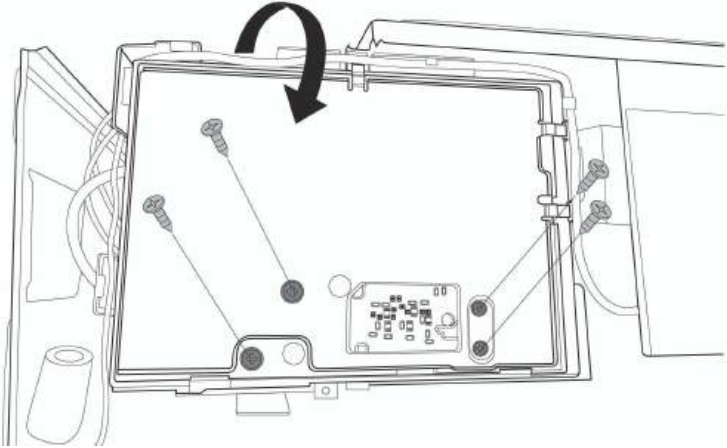
Procedure	Illustration
<p>1) Unfix the hooks and then open the electronic control box cover (4 hooks) (see CJ_ODU_PCB_007-1).</p> <p>2) Remove 4 screws on the electronic control board and then remove the electronic control box subassembly. (see CJ_ODU_PCB_007-2).</p> <p>Note: Electronic installing box cannot be opened, so the voltage between P and N cannot be measured.</p>	 <p data-bbox="879 958 1134 987">CJ_ODU_PCB_007-1</p>  <p data-bbox="879 1648 1134 1677">CJ_ODU_PCB_007-2</p>

Note: This section is for reference only. Actual unit appearance may vary.

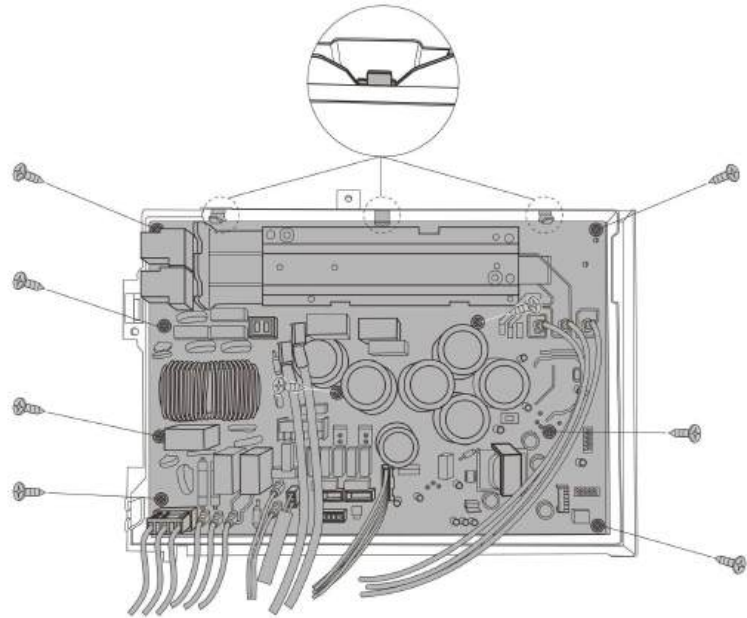
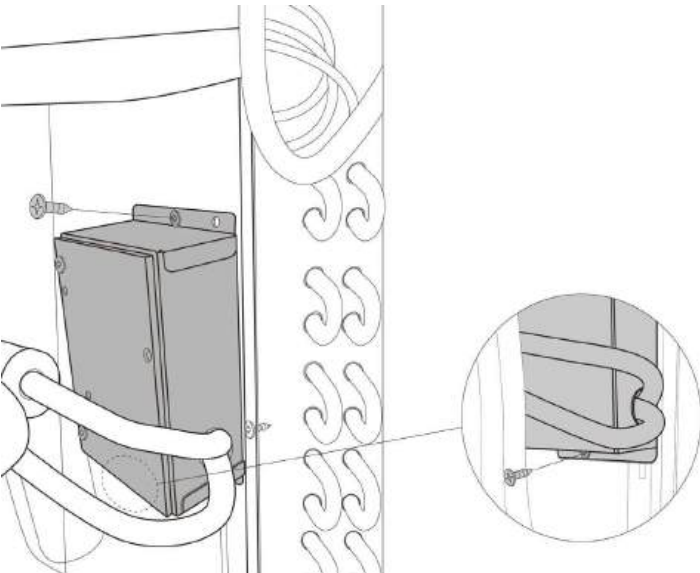
Procedure	Illustration
<p>3) Pull out the connectors (see CJ_ODU_PCB_007-3).</p> <p>4) Remove the 9 screws and unfix the 3 hooks and then remove the electronic control board(see CJ_ODU_PCB_007-3).</p>	 <p style="text-align: center;"><b>CJ_ODU_PCB_007-3</b></p>
<p>5) Remove two screws and then remove the electronic control box subassembly on partition board assembly. (see CJ_ODU_PCB_007-4).</p>	 <p style="text-align: center;"><b>CJ_ODU_PCB_007-4</b></p>

**Note:** This section is for reference only. Actual unit appearance may vary.

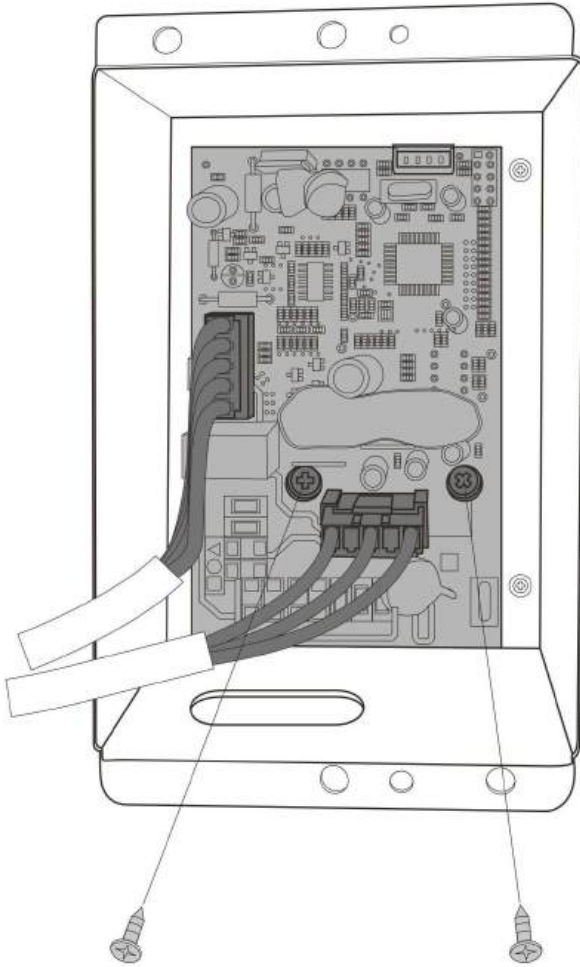

Procedure	Illustration
<p>6) Remove two screws and two connectors and then remove the inverter control board (see CJ_ODU_PCB_007-5).</p>	 <p data-bbox="877 1377 1141 1422">CJ_ODU_PCB_007-5</p>

Note: This section is for reference only. Actual unit appearance may vary.

## 8. PCB board 8

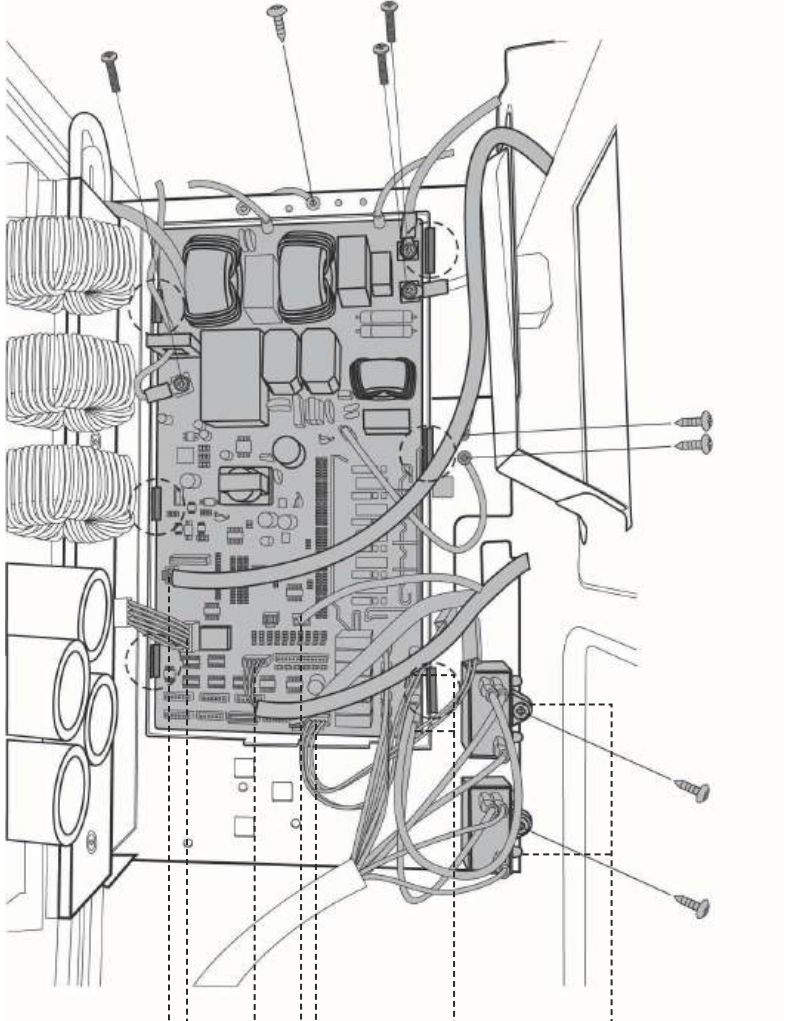
Procedure	Illustration
<ol style="list-style-type: none"> <li>1) Remove 2 screws to disconnect the power supply wires. (see CJ_ODU_PCB_008-1)</li> <li>2) Remove 3 screws to disconnect ground wires. (see CJ_ODU_PCB_008-1)</li> <li>3) Disconnect the wires connected to main control board. (see CJ_ODU_PCB_008-1)</li> <li>4) Disconnect the wires between main control board and IPM module board. (see CJ_ODU_PCB_008-1)</li> <li>5) Remove the 4 screws and unfix the 6 hooks and then remove the main control board. (see CJ_ODU_PCB_008-1)</li> <li>6) Remove 1 screw to remove the fan motor capacitor (1 screw for each capacitor). (see CJ_ODU_PCB_008-1).</li> </ol>	 <p style="text-align: center;">CJ_ODU_PCB_008-1</p>

**Note:** This section is for reference only. Actual unit appearance may vary.

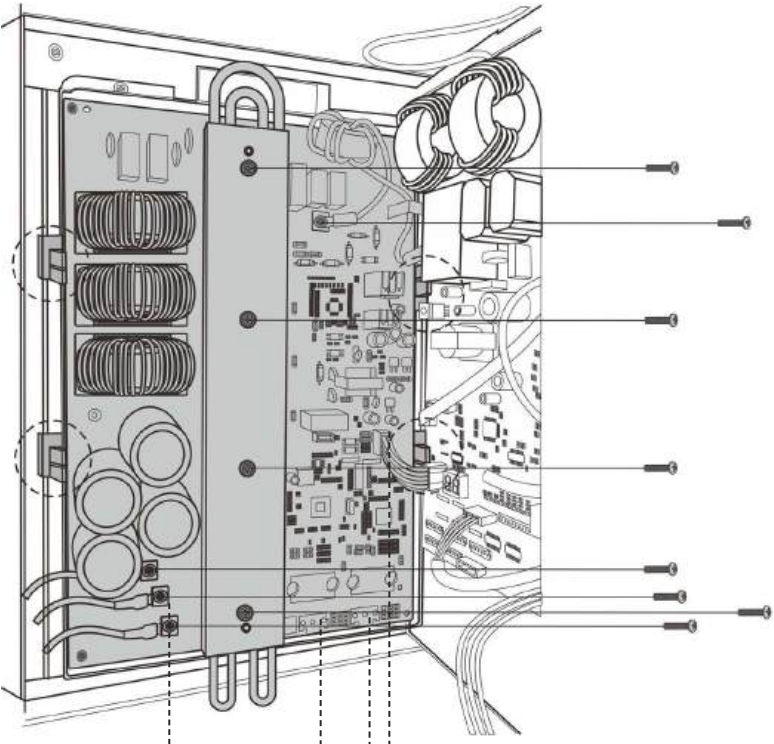
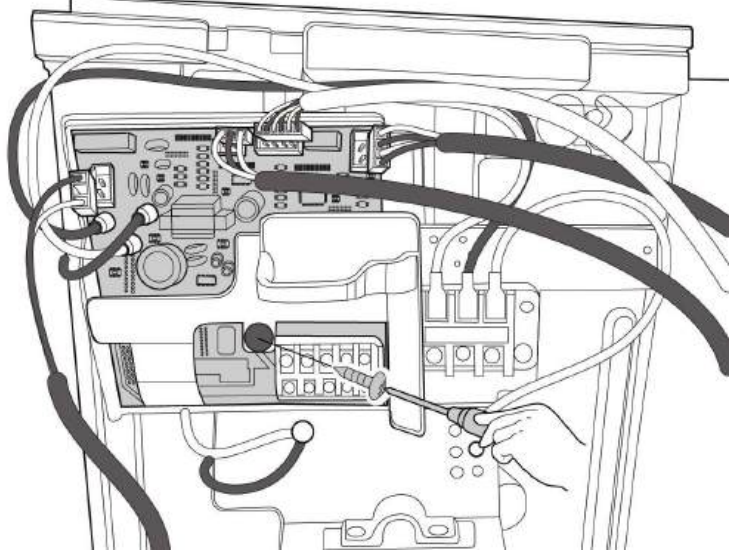
Procedure	Illustration
<ol style="list-style-type: none"> <li>1) Remove 2 screws to disconnect the power supply wires. (see CJ_ODU_PCB_008-2)</li> <li>2) Remove 3 screws to disconnect the wires connected to the compressor. (see CJ_ODU_PCB_008-2)</li> <li>3) Remove 3 screws to remove the radiator.(see CJ_ODU_PCB_008-2)</li> <li>4) Disconnect the wires between IPM module board and main control board. (see CJ_ODU_PCB_008-2)</li> <li>5) Remove the 4 screws and unfix the 4 hooks and then remove the IPM modul board.(see CJ_ODU_PCB_008-2)</li> </ol>	 <p style="text-align: center;"><b>CJ_ODU_PCB_008-2</b></p>
<ol style="list-style-type: none"> <li>6) Remove the 1 screw and disconnect the wires and then remove the 24V board.(see CJ_ODU_PCB_008-3)(for some models)</li> </ol>	 <p style="text-align: center;"><b>CJ_ODU_PCB_008-3(for some models)</b></p>

**Note:** This section is for reference only. Actual unit appearance may vary.

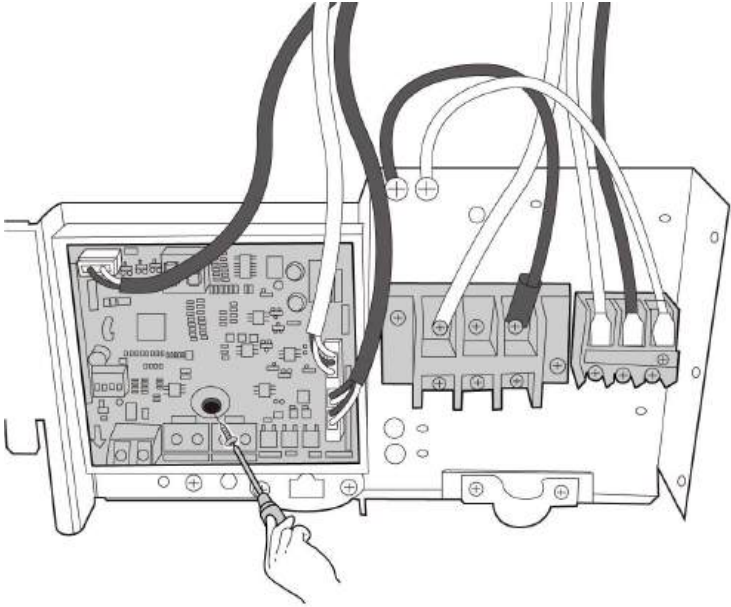
Procedure	Illustration
<p>1) Remove the 1 screw and disconnect the wires and then remove the key board.(see CJ_ODU_PCB_008-4)(for some models)</p>	 <p style="text-align: center;"><b>CJ_ODU_PCB_008-4(for some models)</b></p>

**Note:** This section is for reference only. Actual unit appearance may vary.

## 9. PCB board 9

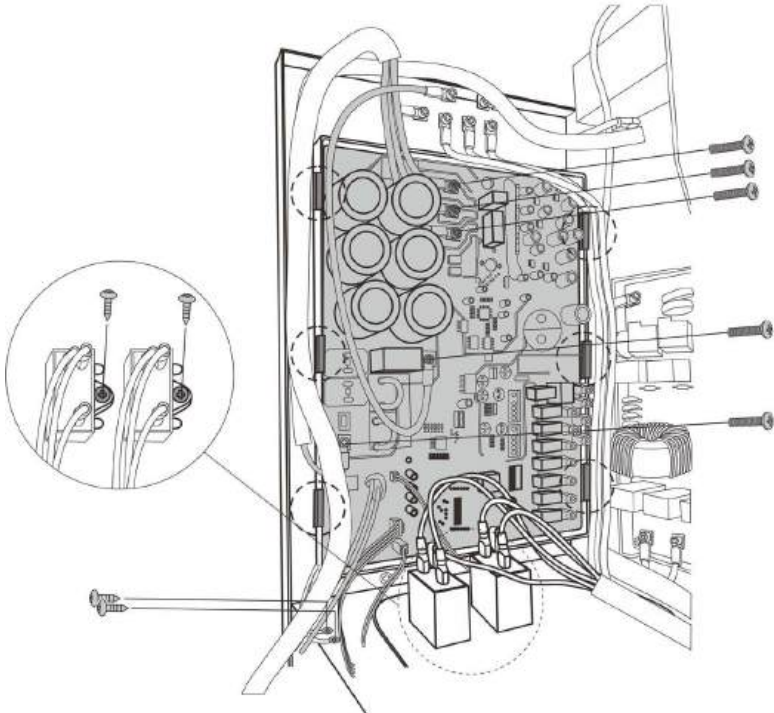
Procedure	Illustration
<p>2) Remove 3 screws to disconnect the wires connected to the compressor. (see CJ_ODU_PCB_009-1)</p> <p>3) Remove 2 screws to disconnect the power supply wires. (see CJ_ODU_PCB_009-1)</p> <p>4) Disconnect the wires connected to main control board. (see CJ_ODU_PCB_009-1)</p> <p>5) Remove the 4 screws and unfix the 6 hooks and then remove the main control board.(see CJ_ODU_PCB_009-1)</p> <p>6) Remove the screw of the fan capacitor and then remove it (1 screw for each capacitor). (see CJ_ODU_PCB_009-1)</p>	 <p style="text-align: center;"><b>CJ_ODU_PCB_009-1</b></p>

**Note:** This section is for reference only. Actual unit appearance may vary.

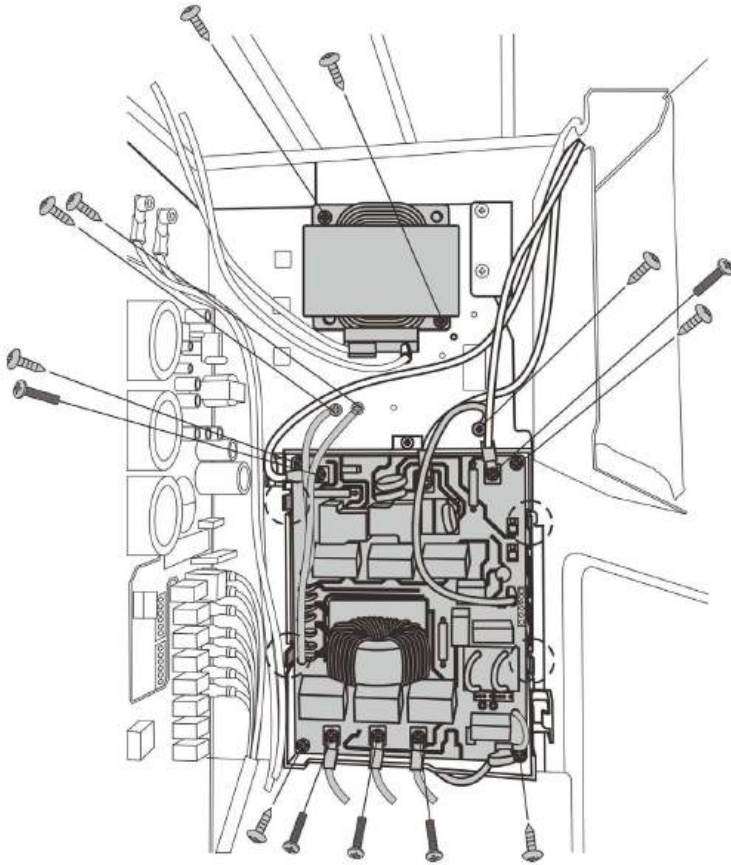
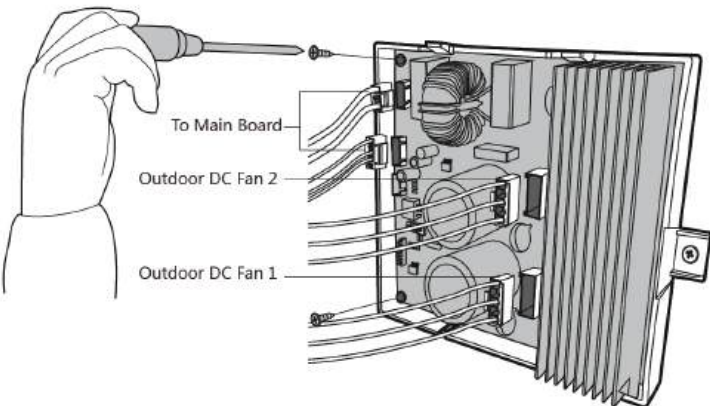
Procedure	Illustration
<p>7) Remove 3 screws to disconnect the power supply wires. (see CJ_ODU_PCB_009-1)</p> <p>8) Remove 3 screws to disconnect ground wires. (see CJ_ODU_PCB_009-1)</p> <p>9) Disconnect the wires connected to main control board. (see CJ_ODU_PCB_009-2)</p> <p>10) Remove the 4 screws and unfix the 4 hooks and then remove the filter board. (see CJ_ODU_PCB_009-2)</p> <p>11) Remove the 2 screws of the reactor and then remove it. (see CJ_ODU_PCB_009-2)</p>	 <p style="text-align: center;"><b>CJ_ODU_PCB_009-2</b></p>
<p>12) Disconnect the wires connected to main control board. (see CJ_ODU_PCB_009-3) (for some models)</p> <p>13) Remove the 2 screws and then remove the DC motor driver board. (see CJ_ODU_PCB_009-3) (for some models)</p>	 <p style="text-align: center;"><b>CJ_ODU_PCB_009-3</b> (for some models)</p>

**Note:** This section is for reference only. Actual unit appearance may vary.

## 10. PCB board 10

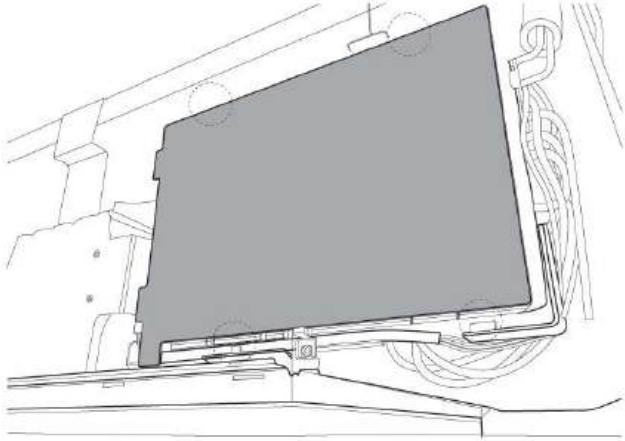
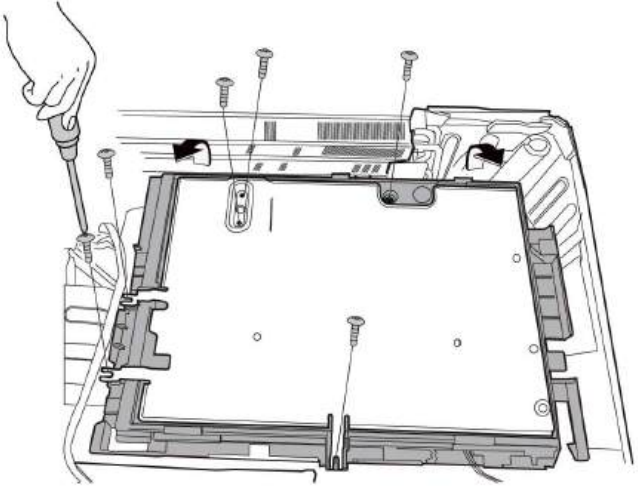
Procedure	Illustration
<p>1) Unfix the hooks and then open the electronic control box cover (4 hooks) (see CJ_ODU_PCB_010-1).</p> <p>2) Remove 6 screws on the electronic control board and then remove the electronic control box subassembly. (see CJ_ODU_PCB_010-2).</p> <p>Note: Electronic installing box cannot be opened, so the voltage between P and N cannot be measured.</p>	 <p style="text-align: center;"><b>CJ_ODU_PCB_010-1</b></p>  <p style="text-align: center;"><b>CJ_ODU_PCB_010-2</b></p>

Note: This section is for reference only. Actual unit appearance may vary.

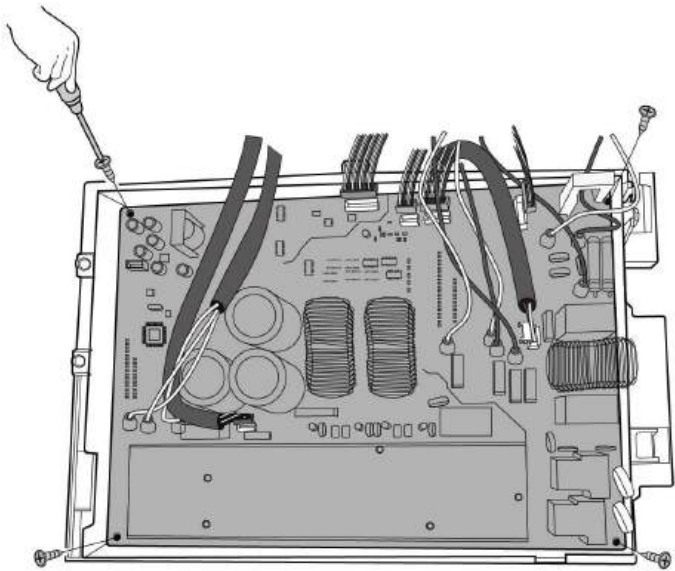
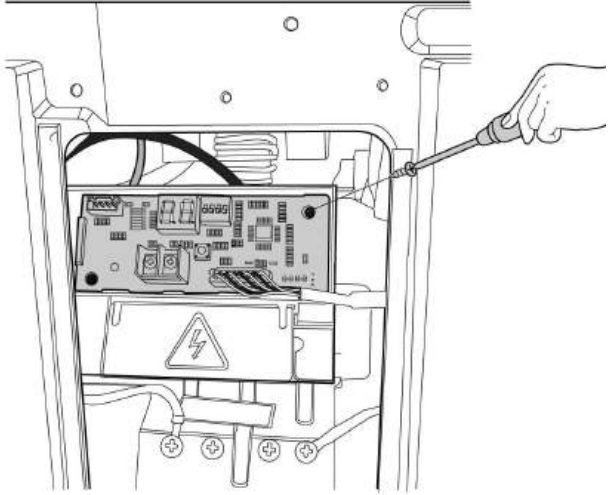
Procedure	Illustration
<p>3) Pull out the connectors (see CJ_ODU_PCB_010-3).</p> <p>4) Remove the 4 screws and then remove the electronic control board(see CJ_ODU_PCB_010-3).</p> <p>Note: When replacing the main control board with a new one, pay attention to applying thermal paste on the heat sink.</p>	 <p style="text-align: center;"><b>CJ_ODU_PCB_010-3</b></p>
<p>5) Pull out the connector, remove one screw and then remove the key board subassembly on terminal board. (see CJ_ODU_PCB_010-4) (for some models).</p>	 <p style="text-align: center;"><b>CJ_ODU_PCB_010-4</b></p>

**Note:** This section is for reference only. Actual unit appearance may vary.

## 11. PCB board 11

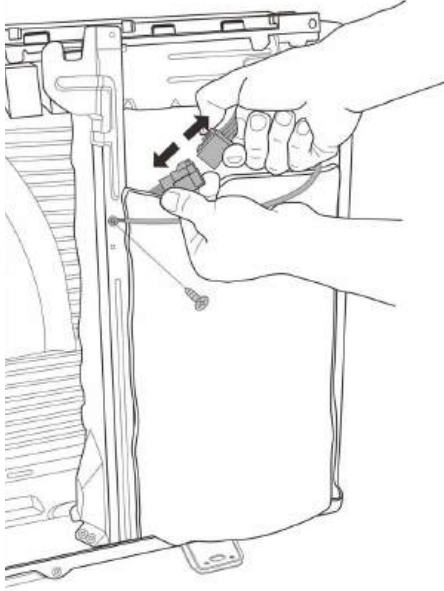
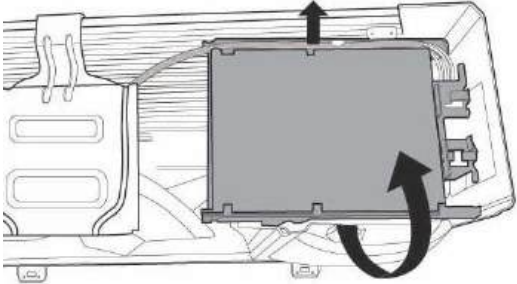
Procedure	Illustration
<p>1) Disconnect the connector for compressor and release the ground wire(1 screw). (see CJ_ODU_PCB_011-1).</p> <p>2) Remove the electronic control box subassembly. (see CJ_ODU_PCB_011-2).</p> <p>Note:Electric control box cover cannot be removed, so the voltage between P and N cannot be measured.</p>	 <p>CJ_ODU_PCB_011-1</p>  <p>CJ_ODU_PCB_011-2</p>

Note: This section is for reference only. Actual unit appearance may vary.

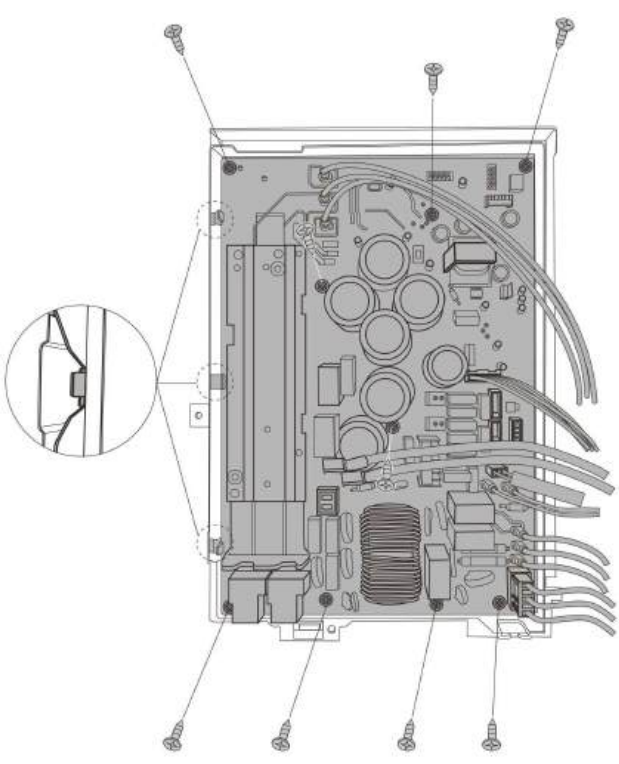
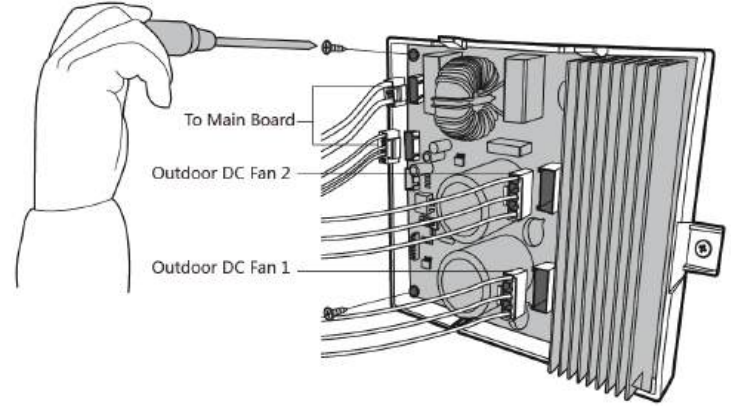

## 12. PCB board 12

Procedure	Illustration
<p>1) Pull out the connectors (see CJ_ODU_PCB_012-1).</p> <p>2) Remove the 9 screws and unfix the 3 hooks and then remove the electronic control board(see CJ_ODU_PCB_012-2).</p>	 <p>The diagram shows the internal components of the PCB board assembly. Nine screws are indicated by dashed circles and leader lines. Three hooks are also indicated by dashed circles and leader lines. A circular inset provides a magnified view of one of the hooks.</p> <p style="text-align: center;"><b>CJ_ODU_PCB_012-1</b></p>
<p>3) Disconnect the wires connected to main control board. (see CJ_ODU_PCB_012-2)(for some models)</p> <p>4) Remove the 2 screws and then remove the DC motor driver board. (see CJ_ODU_PCB_012-2)(for some models)</p>	 <p>The diagram shows a hand using a screwdriver to remove two screws from the DC motor driver board. Labels indicate the connections for 'To Main Board', 'Outdoor DC Fan 2', and 'Outdoor DC Fan 1'.</p> <p style="text-align: center;"><b>CJ_ODU_PCB_012-2</b> (for some models)</p>

**Note:** This section is for reference only. Actual unit appearance may vary.

### 13. PCB board 13

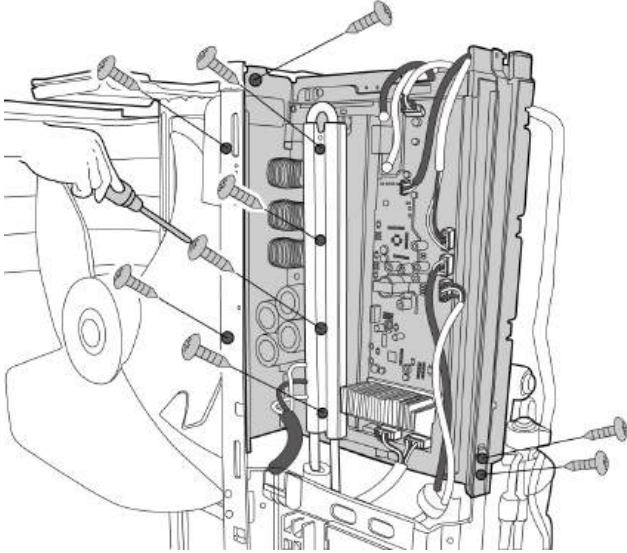
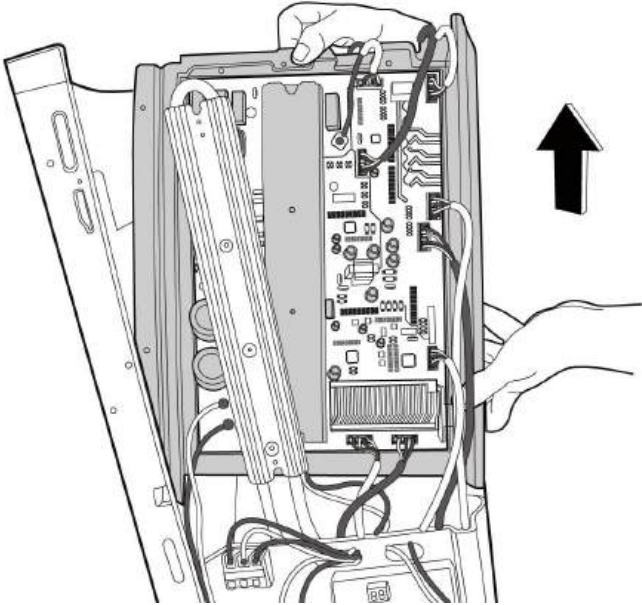
Procedure	Illustration
<p>1) Remove 4 screws unfix the radiator. (see CJ_ODU_PCB_013-1)</p> <p>2) Remove 3 screws unfix the electronic control box assembly and partition board. (see CJ_ODU_PCB_013-1)</p> <p>3) Remove 2 screws unfix the electronic control box assembly and terminal board subassembly. (see CJ_ODU_PCB_013-1)</p> <p>4) Move upward and slowly remove the electronic control box assembly. (CJ_ODU_PCB_013-2)</p> <p>(If you want to repair the electrical control box components, perform the steps 1 to 4; if you want to repair the main control board assembly, perform steps 5 to 7 below.)</p>	 <p data-bbox="895 1010 1150 1039">CJ_ODU_PCB_013-1</p>  <p data-bbox="895 1720 1150 1749">CJ_ODU_PCB_013-2</p>

**Note:** This section is for reference only. Actual unit appearance may vary.

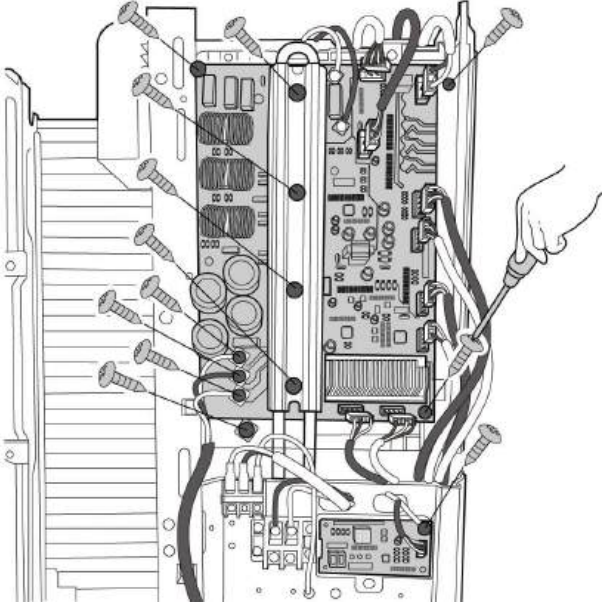
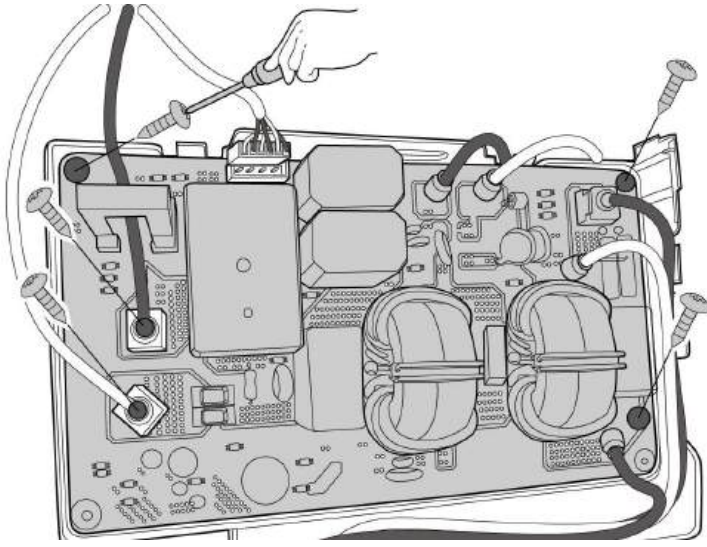
Procedure	Illustration
<p>5) Disconnect the wires connected to main control board. (see CJ_ODU_PCB_013-3)</p> <p>6) Remove the 4 screws and then remove the main control board.(see CJ_ODU_PCB_013-3)</p> <p>7) Remove 1 screw to remove the key board .(see CJ_ODU_PCB_013-3).</p>	 <p style="text-align: center;"><b>CJ_ODU_PCB_013-3</b></p>
<p>8) Disconnect the wires between filter board and main control board. (see CJ_ODU_PCB_013-4)</p> <p>9) Remove the 3 screws and then remove the filter board.(see CJ_ODU_PCB_013-4) (Filter board is on the back of the electronic control box assembly)</p>	 <p style="text-align: center;"><b>CJ_ODU_PCB_013-4</b></p>

**Note:** This section is for reference only. Actual unit appearance may vary.

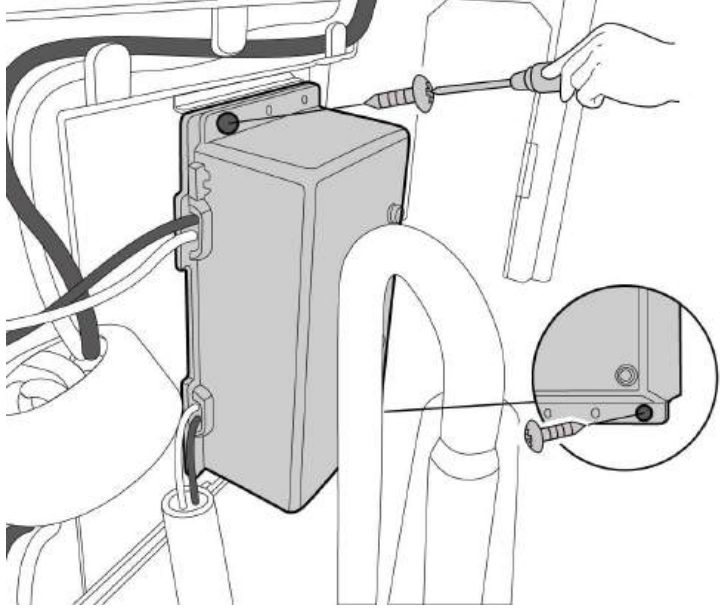
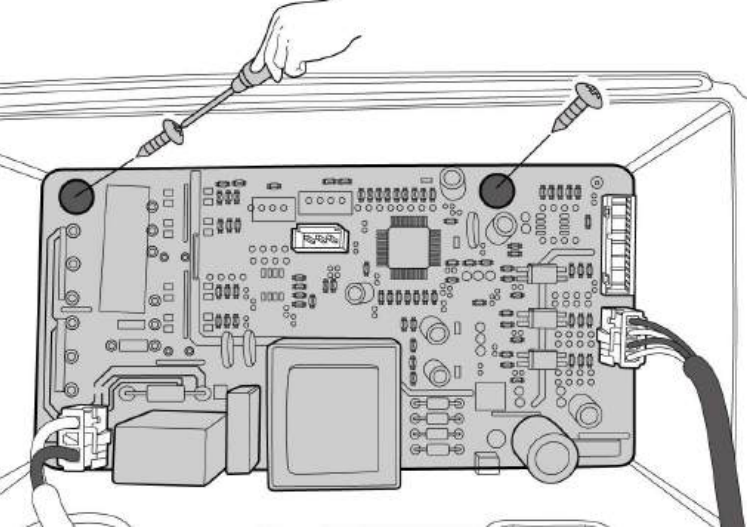
Procedure	Illustration
<p>10) Remove the 2 screws and then remove the DR module box subassembly. (see CJ_ODU_PCB_013-5) (DR module box subassembly is on the back of the electronic control box assembly) (for some models)</p>	 <p style="text-align: center;"><b>CJ_ODU_PCB_013-5 (for some models)</b></p>
<p>11) Remove the 2 screws and then remove the DR module board. (see CJ_ODU_PCB_013-6) (for some models)</p>	 <p style="text-align: center;"><b>CJ_ODU_PCB_013-6 (for some models)</b></p>

**Note:** This section is for reference only. Actual unit appearance may vary.

## 14. PCB board 14

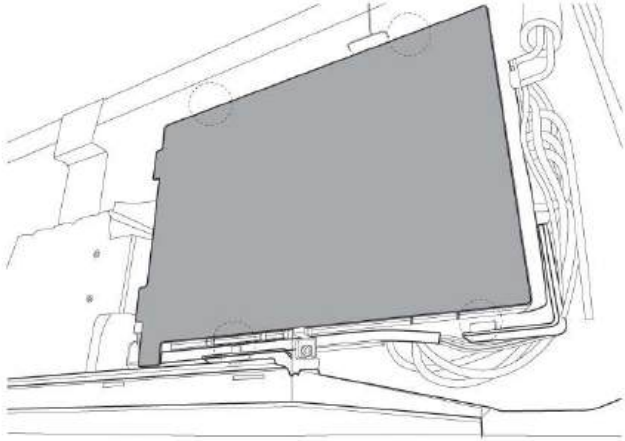
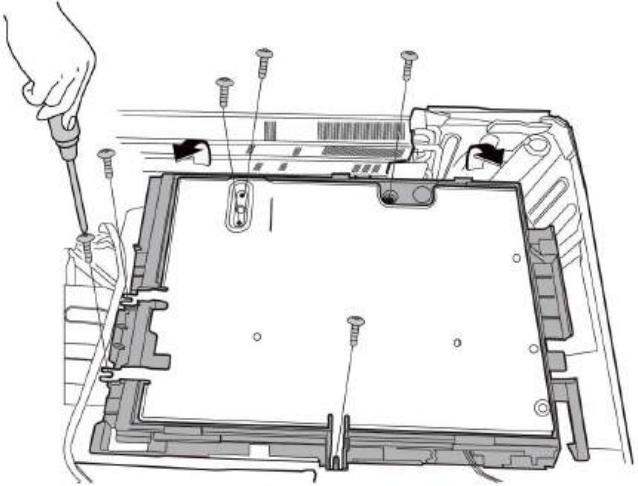
Procedure	Illustration
<p>1) Unfix the hooks and then open the electronic control box cover (4 hooks) (see CJ_ODU_PCB_014-1).</p> <p>2) Remove 6 screws on the electronic control board and then remove the electronic control box subassembly. (see CJ_ODU_PCB_014-2).</p> <p>Note: Electronic installing box cannot be opened, so the voltage between P and N cannot be measured.</p>	 <p style="text-align: center;"><b>CJ_ODU_PCB_014-1</b></p>  <p style="text-align: center;"><b>CJ_ODU_PCB_014-2</b></p>

Note: This section is for reference only. Actual unit appearance may vary.

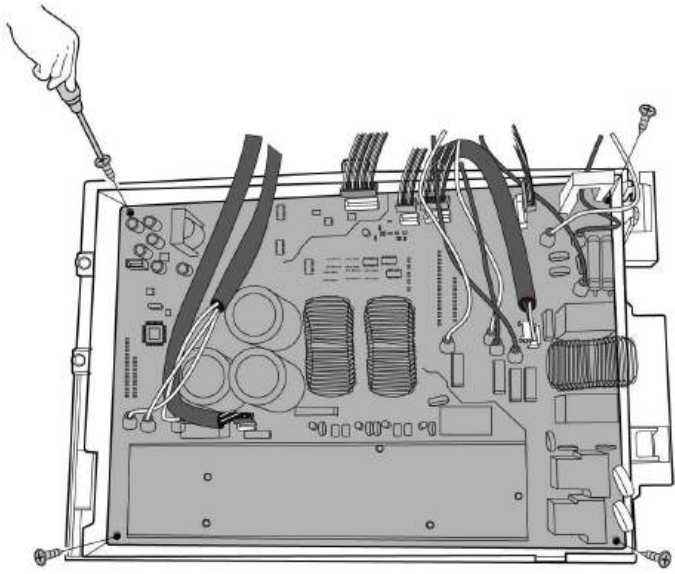
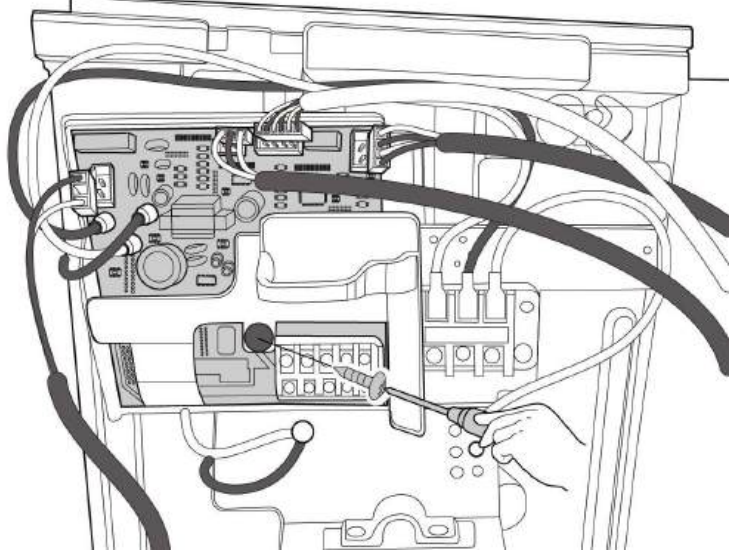
Procedure	Illustration
<p>3) Pull out the connectors (see CJ_ODU_PCB_014-3).</p> <p>4) Remove the 4 screws and then remove the electronic control board(see CJ_ODU_PCB_041-3).</p> <p>Note: When replacing the main control board with a new one, pay attention to applying thermal paste on the heat sink.</p>	 <p style="text-align: center;"><b>CJ_ODU_PCB_014-3</b></p>
<p>5) Remove the 1 screw and disconnect the wires and then remove the 24V board.(see CJ_ODU_PCB_014-4)(for some models)</p>	 <p style="text-align: center;"><b>CJ_ODU_PCB_014-4(for some models)</b></p>

**Note:** This section is for reference only. Actual unit appearance may vary.

## 2.3 Fan Assembly

**Note:** Remove the panel plate (refer to 3.1 Panel Plate) before disassembling fan.

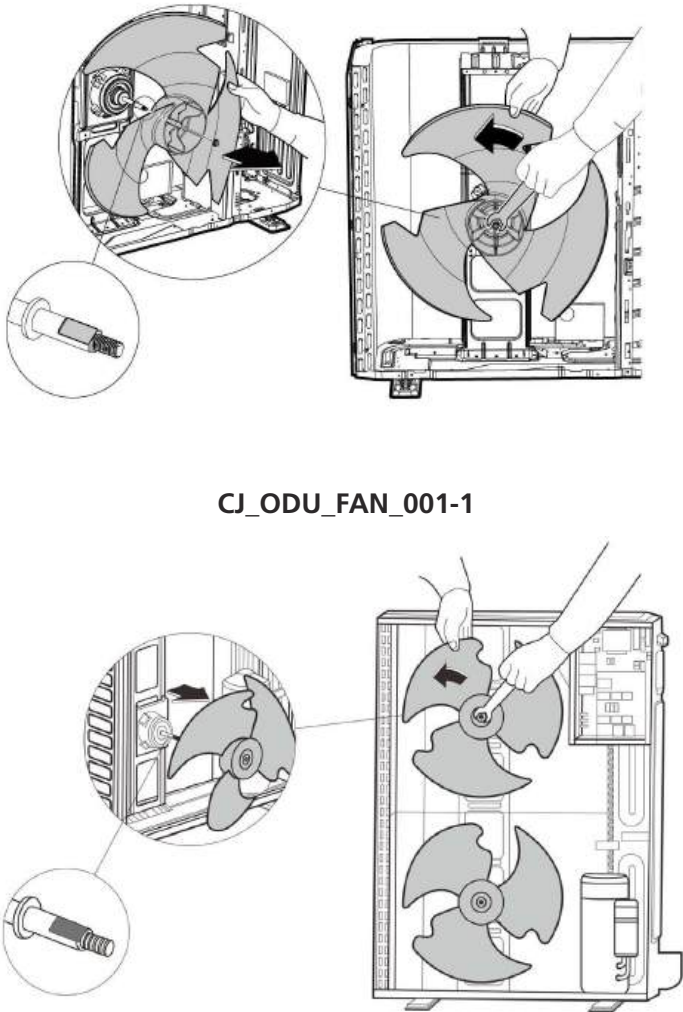
Procedure	Illustration
<p>1) Remove the nut securing the fan with a spanner (see CJ_ODU_FAN_001-1&amp;2).</p> <p>2) Remove the fan.</p>	 <p data-bbox="874 1003 1136 1030">CJ_ODU_FAN_001-1</p> <p data-bbox="874 1572 1136 1599">CJ_ODU_FAN_001-2</p>

**Note:** This section is for reference only. Actual unit appearance may vary.

## 2.4 Fan Motor

**Note:** Remove the panel plate and the connection of fan motor on PCB (refer to 3.1 Panel Plate and 3.2 Electrical parts) before disassembling fan motor.

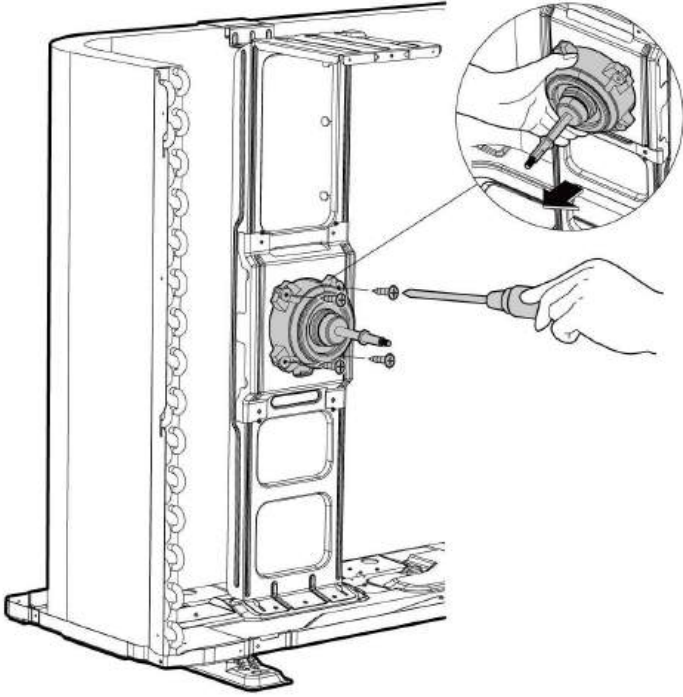
Procedure	Illustration
<p>3) Remove the fixing screws of the fan motor (4 screws) (see CJ_ODU_MOTOR_001).</p> <p>4) Remove the fan motor.</p>	 <p data-bbox="893 1232 1181 1265">CJ_ODU_MOTOR_001</p>

**Note:** This section is for reference only. Actual unit appearance may vary.



## 2.5 Sound blanket

Note: Remove the panel plate (refer to 3.1 Panel plate) before disassembling sound blanket.

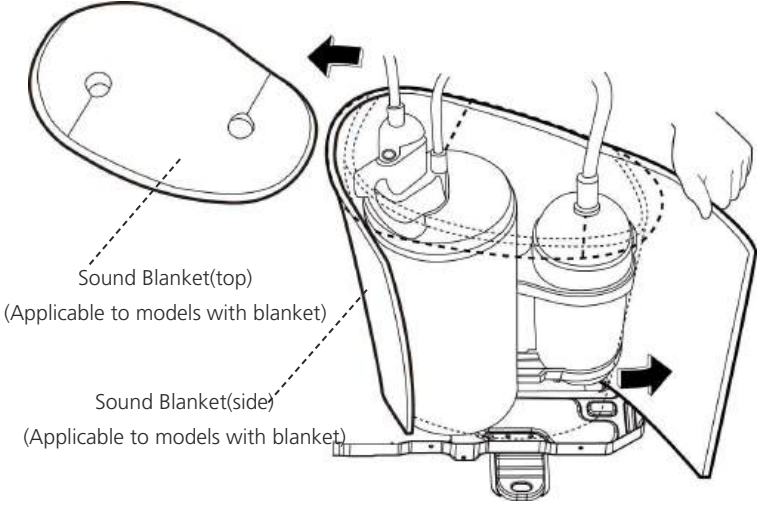
Procedure	Illustration
<p>1) Remove the sound blanket (side and top) (see CJ_ODU_BLANKET_001).</p>	 <p data-bbox="863 974 1166 1008">CJ_ODU_BLANKET_001</p>

Note: This section is for reference only. Actual unit appearance may vary.

## 2.6 Four-way valve (for heat pump models)

**⚠ WARNING:** Evacuate the system and confirm that there is no refrigerant left in the system before removing the four-way valve and the compressor. (For R32 & R290, you should evacuate the system with the vacuum pump; flush the system with nitrogen; then repeat the two steps before heating up the brazed parts. The operations above should be implemented by professionals.)

**Note:** Remove the panel plate, connection of four-way valve on PCB (refer to 3.1 Panel plate and 3.2 Electrical parts) before disassembling sound blanket.

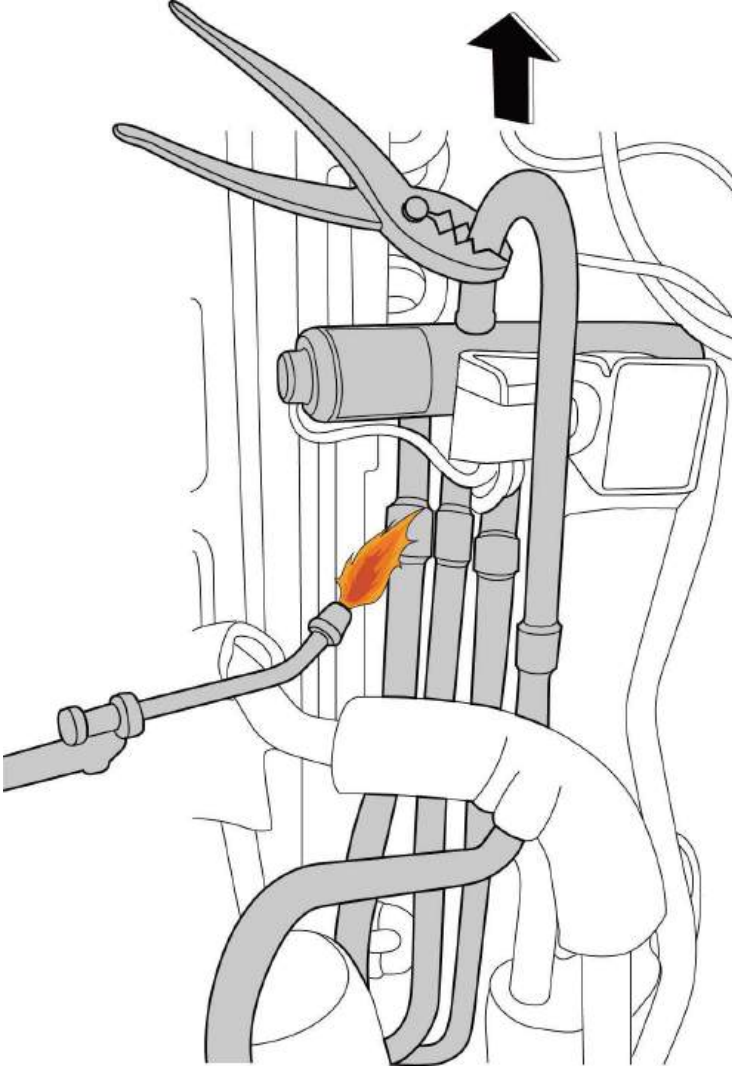
Procedure	Illustration
<ol style="list-style-type: none"><li>1) Heat up the brazed parts and then detach the the four-way valve and the pipe (see CJ_ODU_VALVE_001).</li><li>2) Remove the four-way valve assembly with pliers.</li></ol>	 <p data-bbox="906 1693 1171 1727">CJ_ODU_VALVE_001</p>

**Note:** This section is for reference only. Actual unit appearance may vary.

## 2.7 Compressor

**⚠ WARNING:** Evacuate the system and confirm that there is no refrigerant left in the system before removing the four-way valve and the compressor. (For R32 & R290, you should evacuate the system with the vacuum pump; flush the system with nitrogen; then repeat the two steps before heating up the brazed parts. The operations above should be implemented by professionals.)

**Note:** Remove the panel plate, connection of compressor on PCB (refer to 3.1 Panel plate and 3.2 Electrical parts) before disassembling sound blanket.

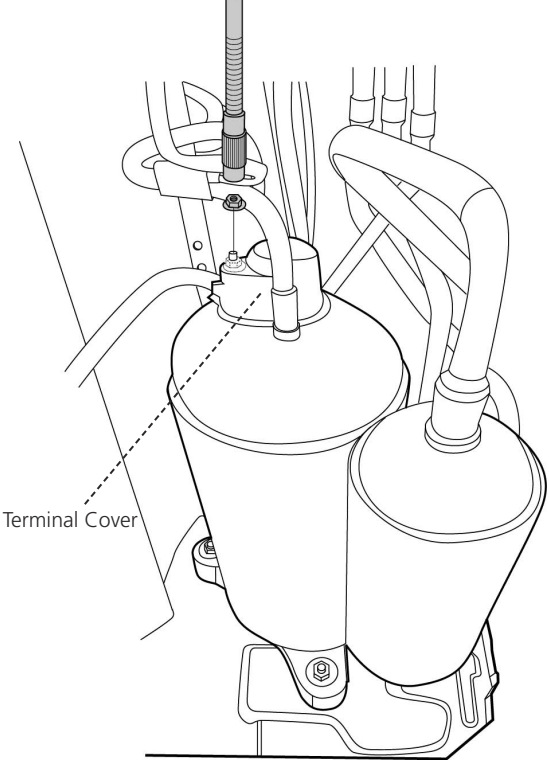
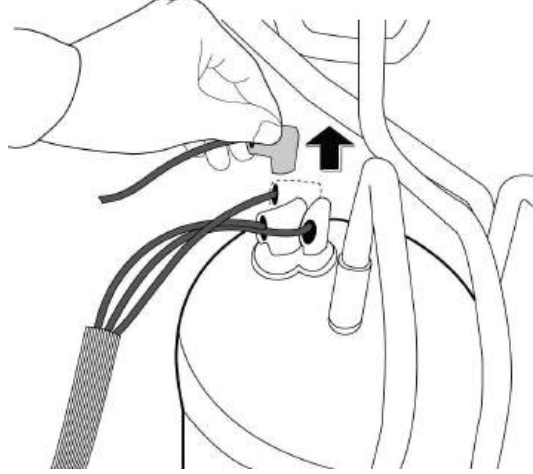
Procedure	Illustration
1) Remove the flange nut of terminal cover and remove the terminal cover (see CJ_ODU_COMP_001).	 <p>The diagram shows a top-down view of the compressor assembly. A dashed line points to a terminal cover on the left side of the unit. The cover is being lifted away from the assembly.</p> <p style="text-align: center;">CJ_ODU_COMP_001</p>
2) Disconnect the connectors (see CJ_ODU_COMP_002).	 <p>The diagram shows a close-up of a hand pulling a connector away from the compressor's terminal block. An upward-pointing arrow indicates the direction of removal.</p> <p style="text-align: center;">CJ_ODU_COMP_002</p>

**Note:** This section is for reference only. Actual unit appearance may vary.

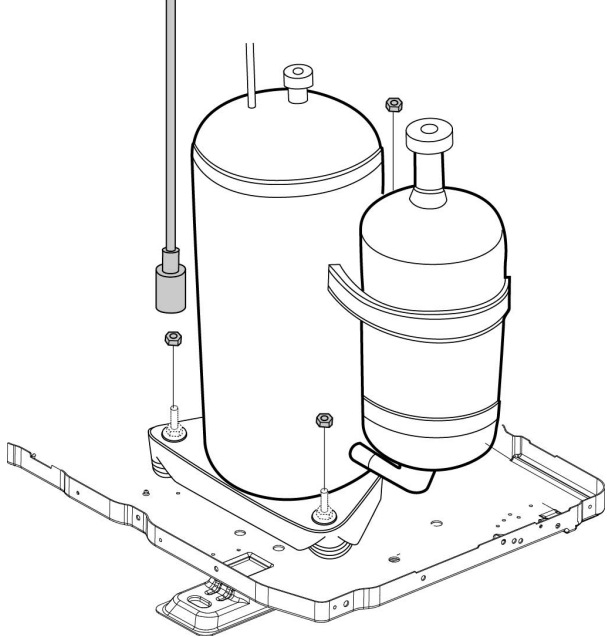
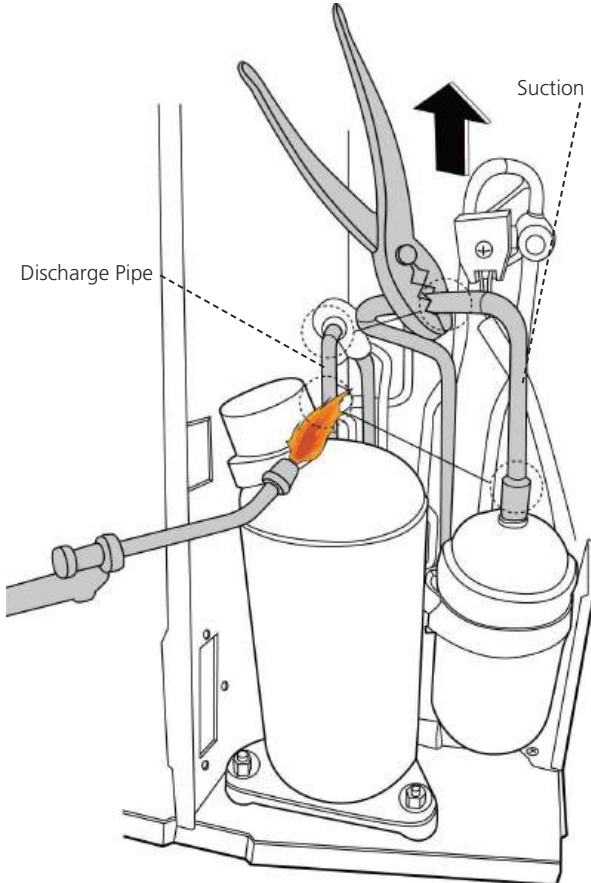
Procedure	Illustration
<p>3) Remove the hex nuts and washers securing the compressor, located on the bottom plate (see CJ_ODU_COMP_003).</p>	 <p style="text-align: center;"><b>CJ_ODU_COMP_003</b></p>
<p>4) Heat up the brazed parts and then remove the the discharge pipe and the suction pipe (see CJ_ODU_COMP_004).</p> <p>5) Lift the compressor from the base pan assembly with pliers.</p>	 <p style="text-align: center;"><b>CJ_ODU_COMP_004</b></p>

**Note:** This section is for reference only. Actual unit appearance may vary.

---

# Appendix

## Contents

i)	Temperature Sensor Resistance Value Table for T1, T2, T3, and T4 (°C – K) .....	2
ii)	Temperature Sensor Resistance Value Table for TP (for some units)(°C --K) .....	3
iii)	Pressure On Service Port .....	4

**i) Temperature Sensor Resistance Value Table for T1,T2,T3 and T4 (°C – K)**

°C	°F	K Ohm	°C	°F	K Ohm	°C	°F	K Ohm	°C	°F	K Ohm
-20	-4	115.266	20	68	12.6431	60	140	2.35774	100	212	0.62973
-19	-2	108.146	21	70	12.0561	61	142	2.27249	101	214	0.61148
-18	0	101.517	22	72	11.5	62	144	2.19073	102	216	0.59386
-17	1	96.3423	23	73	10.9731	63	145	2.11241	103	217	0.57683
-16	3	89.5865	24	75	10.4736	64	147	2.03732	104	219	0.56038
-15	5	84.219	25	77	10	65	149	1.96532	105	221	0.54448
-14	7	79.311	26	79	9.55074	66	151	1.89627	106	223	0.52912
-13	9	74.536	27	81	9.12445	67	153	1.83003	107	225	0.51426
-12	10	70.1698	28	82	8.71983	68	154	1.76647	108	226	0.49989
-11	12	66.0898	29	84	8.33566	69	156	1.70547	109	228	0.486
-10	14	62.2756	30	86	7.97078	70	158	1.64691	110	230	0.47256
-9	16	58.7079	31	88	7.62411	71	160	1.59068	111	232	0.45957
-8	18	56.3694	32	90	7.29464	72	162	1.53668	112	234	0.44699
-7	19	52.2438	33	91	6.98142	73	163	1.48481	113	235	0.43482
-6	21	49.3161	34	93	6.68355	74	165	1.43498	114	237	0.42304
-5	23	46.5725	35	95	6.40021	75	167	1.38703	115	239	0.41164
-4	25	44	36	97	6.13059	76	169	1.34105	116	241	0.4006
-3	27	41.5878	37	99	5.87359	77	171	1.29078	117	243	0.38991
-2	28	39.8239	38	100	5.62961	78	172	1.25423	118	244	0.37956
-1	30	37.1988	39	102	5.39689	79	174	1.2133	119	246	0.36954
0	32	35.2024	40	104	5.17519	80	176	1.17393	120	248	0.35982
1	34	33.3269	41	106	4.96392	81	178	1.13604	121	250	0.35042
2	36	31.5635	42	108	4.76253	82	180	1.09958	122	252	0.3413
3	37	29.9058	43	109	4.5705	83	181	1.06448	123	253	0.33246
4	39	28.3459	44	111	4.38736	84	183	1.03069	124	255	0.3239
5	41	26.8778	45	113	4.21263	85	185	0.99815	125	257	0.31559
6	43	25.4954	46	115	4.04589	86	187	0.96681	126	259	0.30754
7	45	24.1932	47	117	3.88673	87	189	0.93662	127	261	0.29974
8	46	22.5662	48	118	3.73476	88	190	0.90753	128	262	0.29216
9	48	21.8094	49	120	3.58962	89	192	0.8795	129	264	0.28482
10	50	20.7184	50	122	3.45097	90	194	0.85248	130	266	0.2777
11	52	19.6891	51	124	3.31847	91	196	0.82643	131	268	0.27078
12	54	18.7177	52	126	3.19183	92	198	0.80132	132	270	0.26408
13	55	17.8005	53	127	3.07075	93	199	0.77709	133	271	0.25757
14	57	16.9341	54	129	2.95896	94	201	0.75373	134	273	0.25125
15	59	16.1156	55	131	2.84421	95	203	0.73119	135	275	0.24512
16	61	15.3418	56	133	2.73823	96	205	0.70944	136	277	0.23916
17	63	14.6181	57	135	2.63682	97	207	0.68844	137	279	0.23338
18	64	13.918	58	136	2.53973	98	208	0.66818	138	280	0.22776
19	66	13.2631	59	138	2.44677	99	210	0.64862	139	282	0.22231

**ii) Temperature Sensor Resistance Value Table for TP(for some units) (°C --K)**

°C	°F	K Ohm	°C	°F	K Ohm	°C	°F	K Ohm	°C	°F	K Ohm
°C	°F	K Ohm	°C	°F	K Ohm	°C	°F	K Ohm	°C	°F	K Ohm
-20	-4	542.7	20	68	68.66	60	140	13.59	100	212	3.702
-19	-2	511.9	21	70	65.62	61	142	13.11	101	214	3.595
-18	0	483	22	72	62.73	62	144	12.65	102	216	3.492
-17	1	455.9	23	73	59.98	63	145	12.21	103	217	3.392
-16	3	430.5	24	75	57.37	64	147	11.79	104	219	3.296
-15	5	406.7	25	77	54.89	65	149	11.38	105	221	3.203
-14	7	384.3	26	79	52.53	66	151	10.99	106	223	3.113
-13	9	363.3	27	81	50.28	67	153	10.61	107	225	3.025
-12	10	343.6	28	82	48.14	68	154	10.25	108	226	2.941
-11	12	325.1	29	84	46.11	69	156	9.902	109	228	2.86
-10	14	307.7	30	86	44.17	70	158	9.569	110	230	2.781
-9	16	291.3	31	88	42.33	71	160	9.248	111	232	2.704
-8	18	275.9	32	90	40.57	72	162	8.94	112	234	2.63
-7	19	261.4	33	91	38.89	73	163	8.643	113	235	2.559
-6	21	247.8	34	93	37.3	74	165	8.358	114	237	2.489
-5	23	234.9	35	95	35.78	75	167	8.084	115	239	2.422
-4	25	222.8	36	97	34.32	76	169	7.82	116	241	2.357
-3	27	211.4	37	99	32.94	77	171	7.566	117	243	2.294
-2	28	200.7	38	100	31.62	78	172	7.321	118	244	2.233
-1	30	190.5	39	102	30.36	79	174	7.086	119	246	2.174
0	32	180.9	40	104	29.15	80	176	6.859	120	248	2.117
1	34	171.9	41	106	28	81	178	6.641	121	250	2.061
2	36	163.3	42	108	26.9	82	180	6.43	122	252	2.007
3	37	155.2	43	109	25.86	83	181	6.228	123	253	1.955
4	39	147.6	44	111	24.85	84	183	6.033	124	255	1.905
5	41	140.4	45	113	23.89	85	185	5.844	125	257	1.856
6	43	133.5	46	115	22.89	86	187	5.663	126	259	1.808
7	45	127.1	47	117	22.1	87	189	5.488	127	261	1.762
8	46	121	48	118	21.26	88	190	5.32	128	262	1.717
9	48	115.2	49	120	20.46	89	192	5.157	129	264	1.674
10	50	109.8	50	122	19.69	90	194	5	130	266	1.632
11	52	104.6	51	124	18.96	91	196	4.849			
12	54	99.69	52	126	18.26	92	198	4.703			
13	55	95.05	53	127	17.58	93	199	4.562			
14	57	90.66	54	129	16.94	94	201	4.426			
15	59	86.49	55	131	16.32	95	203	4.294			
16	61	82.54	56	133	15.73	96	205	4.167			
17	63	78.79	57	135	15.16	97	207	4.045			
18	64	75.24	58	136	14.62	98	208	3.927			
19	66	71.86	59	138	14.09	99	210	3.812			

### iii) Pressure On Service Port

#### Cooling chart(R410A):

°F(°C)	ODU(DB)		0(-17)	5(-15)	15 (-9.44)	45 (7.22)	75 (23.89)	85 (29.44)	95 (35)	105 (40.56)	115 (46.11)	120 (48.89)
	IDU(DB/WB)											
BAR	70/59 (21.11/15)		6.4	6.5	7.3	8.0	8.2	7.8	8.1	8.6	10.1	10.6
	75/63 (23.89/17.22)		6.7	6.8	7.9	8.6	8.6	8.3	8.7	9.1	10.7	11.2
	80/67 (26.67/19.44)		7.1	7.2	8.5	9.5	9.3	8.9	9.1	9.6	11.2	11.9
	90/73 (32.22/22.78)		7.7	7.8	9.6	10.5	10.3	9.5	10.0	10.6	12.4	13.0
PSI	70/59 (21.11/15)		93	94	106	116	119	113	117	125	147	154
	75/63 (23.89/17.22)		97	99	115	125	124	120	126	132	155	162
	80/67 (26.67/19.44)		103	104	123	138	135	129	132	140	162	173
	90/73 (32.22/22.78)		112	113	139	152	149	138	145	154	180	189
MPa	70/59 (21.11/15)		0.64	0.65	0.73	0.8	0.82	0.78	0.81	0.86	1.01	1.06
	75/63 (23.89/17.22)		0.67	0.68	0.79	0.86	0.86	0.83	0.87	0.91	1.07	1.12
	80/67 (26.67/19.44)		0.71	0.72	0.85	0.95	0.93	0.89	0.91	0.96	1.12	1.19
	90/73 (32.22/22.78)		0.77	0.78	0.96	1.05	1.03	0.95	1	1.06	1.24	1.3

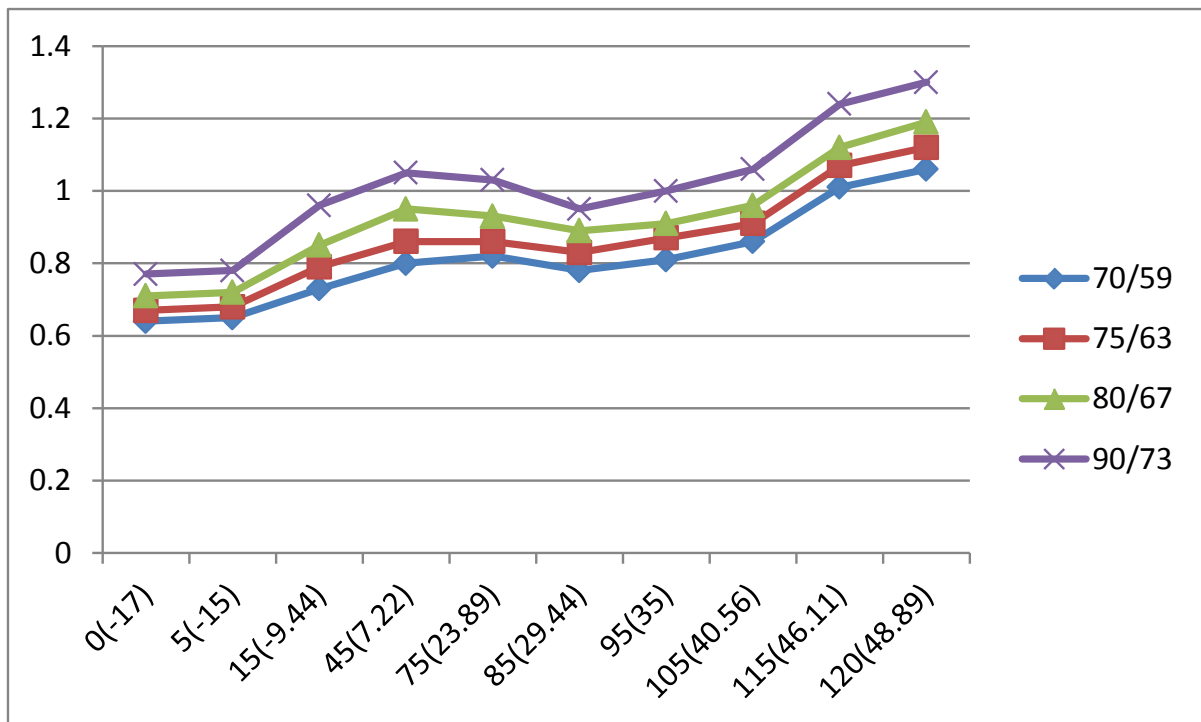



### Heating chart(R410A):

°F(°C)	ODU(DB/WB)	57/53 (13.89/11.67)	47/43 (8.33/6.11)	37/33 (2.78/0.56)	27/23 (-2.78/-5)	17/13 (-8.33/ -10.56)	0/-2 (-17/-19)	-17/-18 (-27/-28)
	IDU(DB)							
BAR	55(12.78)	30.3	28.5	25.3	22.8	20.8	18.5	16.5
	65(18.33)	32.5	30.0	26.6	25.4	23.3	20.5	19.0
	75(23.89)	33.8	31.5	27.8	26.3	24.9	21.5	20.0
PSI	55(12.78)	439	413	367	330	302	268	239
	65(18.33)	471	435	386	368	339	297	276
	75(23.89)	489	457	403	381	362	312	290
MPa	55(12.78)	3.03	2.85	2.53	2.28	2.08	1.85	1.65
	65(18.33)	3.25	3.00	2.66	2.54	2.33	2.05	1.90
	75(23.89)	3.38	3.15	2.78	2.63	2.49	2.15	2.00

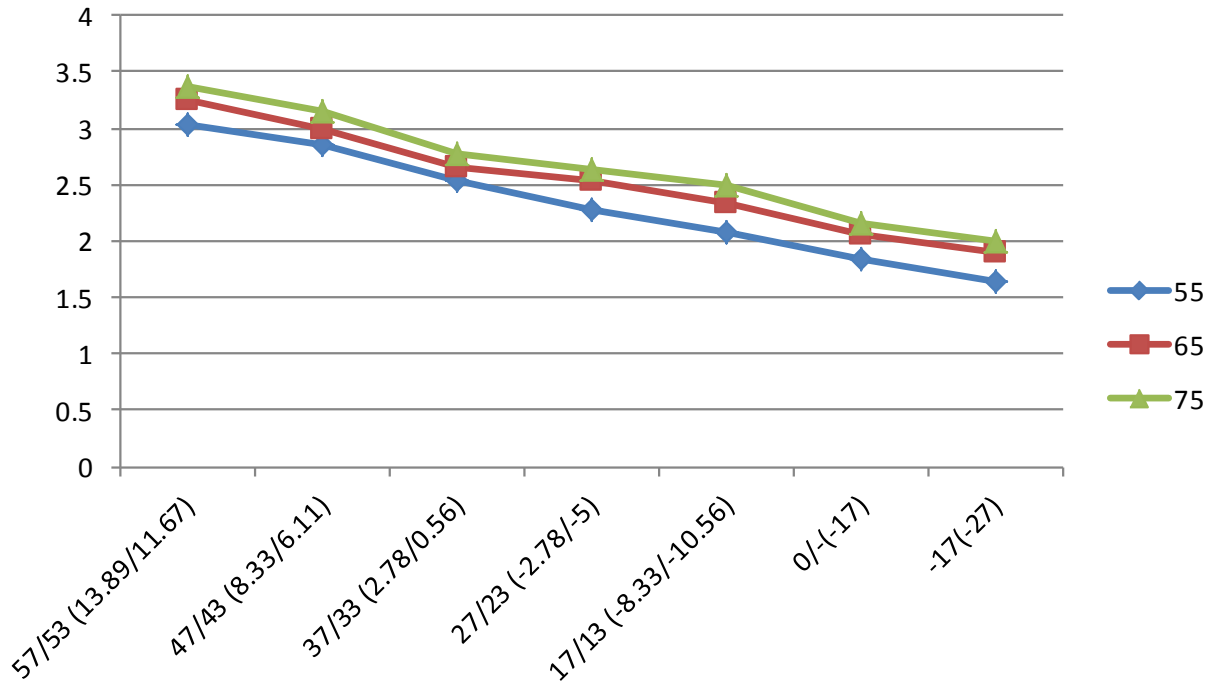

**Cooling chart(R22):**

°F(°C)	ODU(DB)		0(-17)	5(-15)	15(-9.44)	45(7.22)	75(23.89)	85(29.44)	95(35)	105(40.56)	115(46.11)	120(48.89)
	IDU(DB/WB)											
BAR	70/59 (21.11/15)		4.0	4.1	4.6	5.0	5.1	4.9	5.1	5.4	6.3	6.6
	75/63 (23.89/17.22)		4.2	4.3	4.9	5.4	5.4	5.2	5.4	5.7	6.7	7.0
	80/67 (26.67/19.44)		4.4	4.5	5.3	5.9	5.8	5.6	5.7	6.0	7.0	7.4
	90/73 (32.22/22.78)		4.8	4.9	6.0	6.6	6.4	5.9	6.3	6.6	7.8	8.1
PSI	70/59 (21.11/15)		58	59	67	73	74	71	74	78	91	96
	75/63 (23.89/17.22)		61	62	71	78	78	75	78	83	97	102
	80/67 (26.67/19.44)		64	65	77	86	84	81	83	87	102	107
	90/73 (32.22/22.78)		70	71	87	96	93	86	91	96	113	117
MPa	70/59 (21.11/15)		0.40	0.41	0.46	0.50	0.51	0.49	0.51	0.54	0.63	0.66
	75/63 (23.89/17.22)		0.42	0.43	0.49	0.54	0.54	0.52	0.54	0.57	0.67	0.70
	80/67 (26.67/19.44)		0.44	0.45	0.53	0.59	0.58	0.56	0.57	0.60	0.70	0.74
	90/73 (32.22/22.78)		0.48	0.49	0.60	0.66	0.64	0.59	0.63	0.66	0.78	0.81

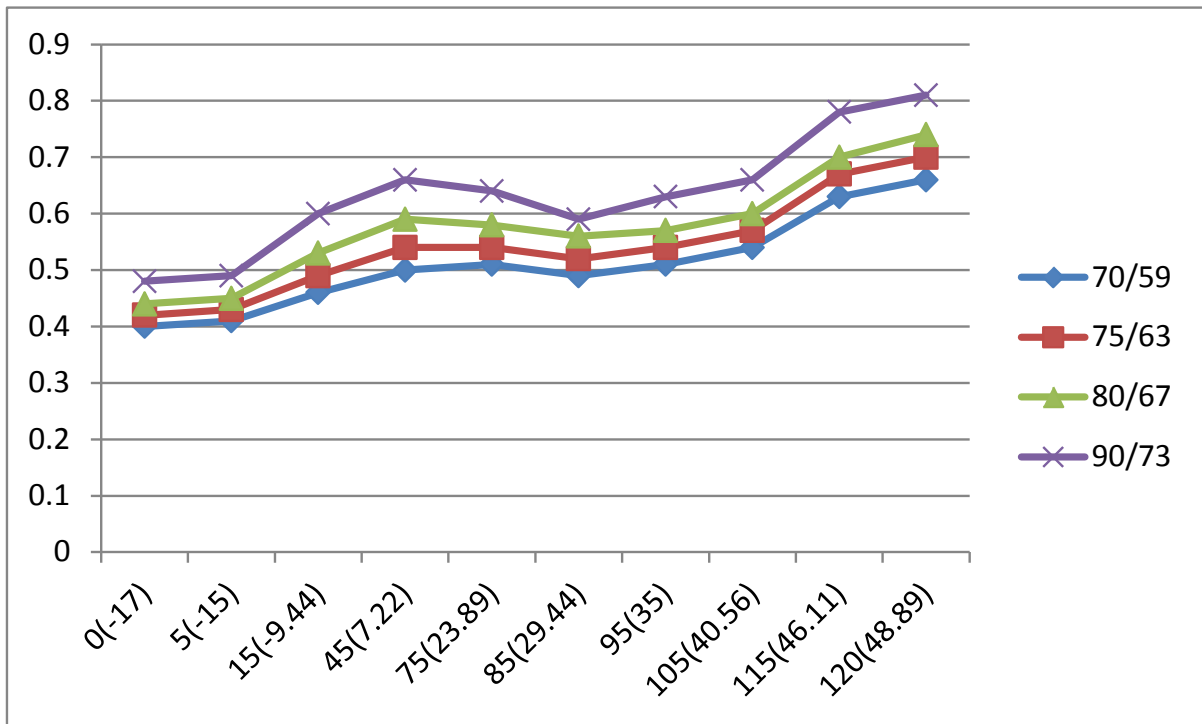

### Heating chart(R22):

°F(°C)	ODU(DB/WB)	57/53 (13.89/11.67)	47/43 (8.33/6.11)	37/33 (2.78/0.56)	27/23 (-2.78/-5)	17/13 (-8.33/ -10.56)	0/-2 (-17/-19)	-17/-18 (-27/-28)
	IDU(DB)							
BAR	55(12.78)	18.9	17.8	15.8	14.3	13.0	11.6	10.3
	65(18.33)	20.3	18.8	16.6	15.9	14.6	12.8	11.9
	75(23.89)	21.1	19.7	17.3	16.4	15.6	13.4	12.5
PSI	55(12.78)	274	258	229	207	189	168	149
	65(18.33)	294	273	241	231	212	186	172.6
	75(23.89)	306	286	251	238	226	194	181
MPa	55(12.78)	1.89	1.78	1.58	1.43	1.30	1.16	1.03
	65(18.33)	2.03	1.88	1.66	1.59	1.46	1.28	1.19
	75(23.89)	2.11	1.97	1.73	1.64	1.56	1.34	1.25

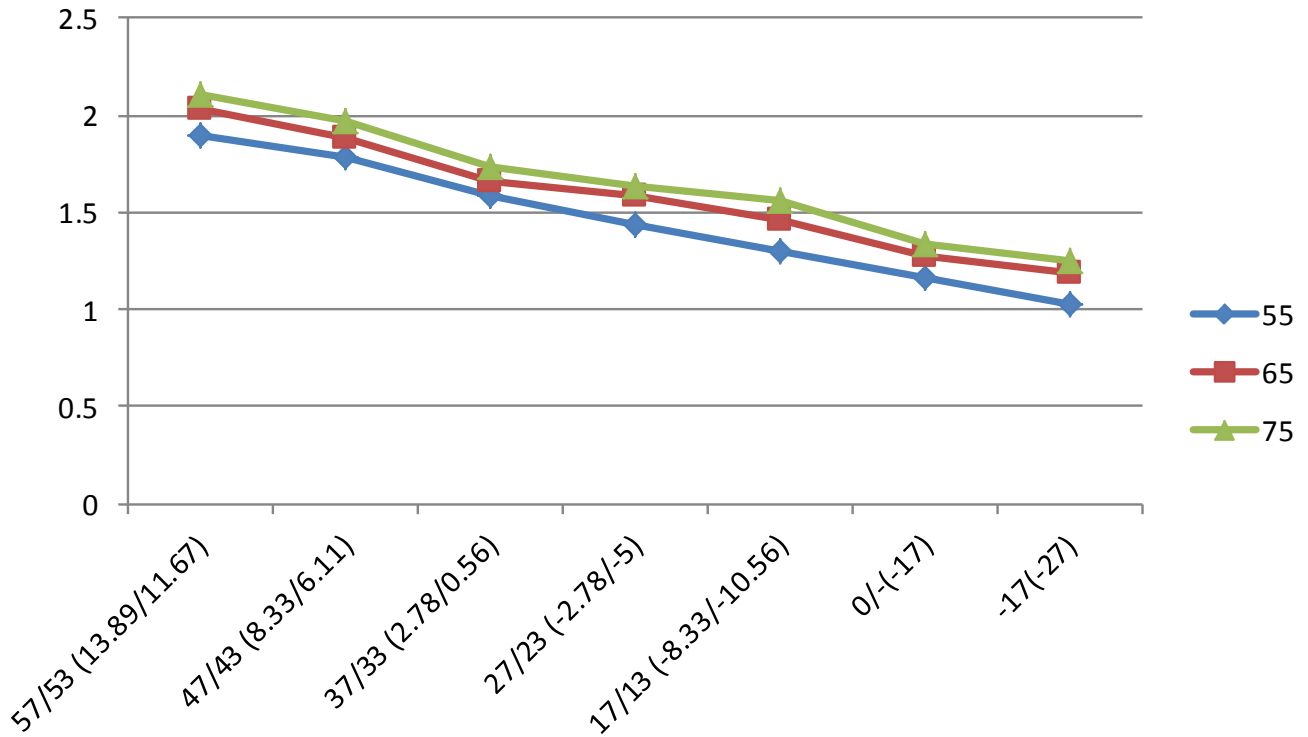

### Cooling chart(R32):

°F(°C)	ODU(DB)		0(-17)	5(-15)	15(-9.44)	45(7.22)	75(23.89)	85(29.44)	95(35)	105(40.56)	115(46.11)	120(48.89)
	IDU(DB/WB)											
BAR	70/59 (21.11/15)		6.5	6.6	7.4	8.2	8.4	8.0	8.3	8.8	10.3	10.8
	75/63 (23.89/17.22)		6.8	6.9	8.1	8.8	8.8	8.5	8.9	9.3	10.9	11.4
	80/67 (26.67/19.44)		7.2	7.3	8.7	9.7	9.5	9.1	9.3	9.8	11.4	12.1
	90/73 (32.22/22.78)		7.9	8.0	9.8	10.7	10.5	9.7	10.2	10.8	12.6	13.3
PSI	70/59 (21.11/15)		95	96	108	118	121	115	119	128	150	157
	75/63 (23.89/17.22)		99	101	117	128	126	122	129	135	158	165
	80/67 (26.67/19.44)		105	106	125	141	138	132	135	143	165	176
	90/73 (32.22/22.78)		114	115	142	155	152	141	148	157	184	193
MPa	70/59 (21.11/15)		0.65	0.66	0.74	0.82	0.84	0.80	0.83	0.88	1.03	1.08
	75/63 (23.89/17.22)		0.68	0.69	0.81	0.88	0.88	0.85	0.89	0.93	1.09	1.14
	80/67 (26.67/19.44)		0.72	0.73	0.87	0.97	0.95	0.91	0.93	0.98	1.14	1.21
	90/73 (32.22/22.78)		0.79	0.80	0.98	1.07	1.05	0.97	1.02	1.08	1.26	1.33

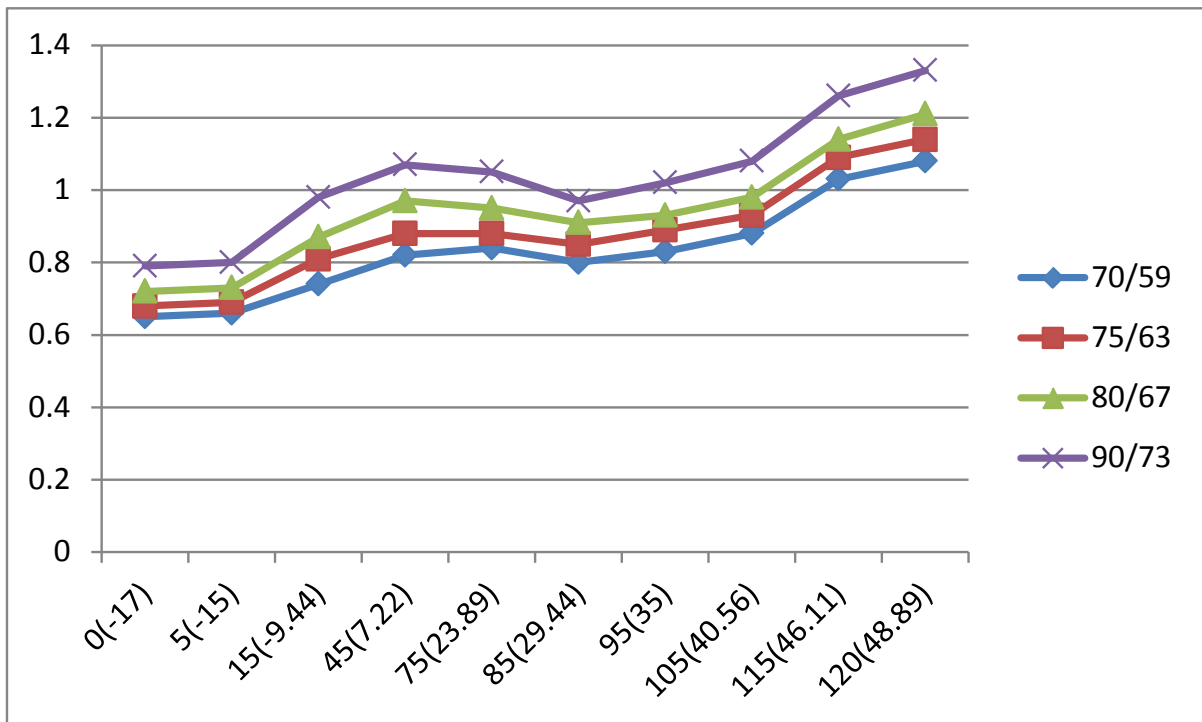

### Heating chart(R32):

°F(°C)	ODU(DB/WB)	57/53 (13.89/11.67)	47/43 (8.33/6.11)	37/33 (2.78/0.56)	27/23 (-2.78/-5)	17/13 (-8.33/- 10.56)	0/-2 (-17/-19)	-17/-18 (-27/-28)
	IDU(DB)							
BAR	55(12.78)	30.9	29.1	25.8	23.3	21.2	18.9	16.8
	65(18.33)	33.2	30.6	27.1	25.9	23.8	20.9	19.4
	75(23.89)	34.5	32.1	28.4	26.8	25.4	21.9	20.4
PSI	55(12.78)	448	421	374	337	308	273	244
	65(18.33)	480	444	394	375	346	303	282
	75(23.89)	499	466	411	389	369	318	296
MPa	55(12.78)	3.09	2.91	2.58	2.33	2.12	1.89	1.68
	65(18.33)	3.32	3.06	2.71	2.59	2.38	2.09	1.94
	75(23.89)	3.45	3.21	2.84	2.68	2.54	2.19	2.04

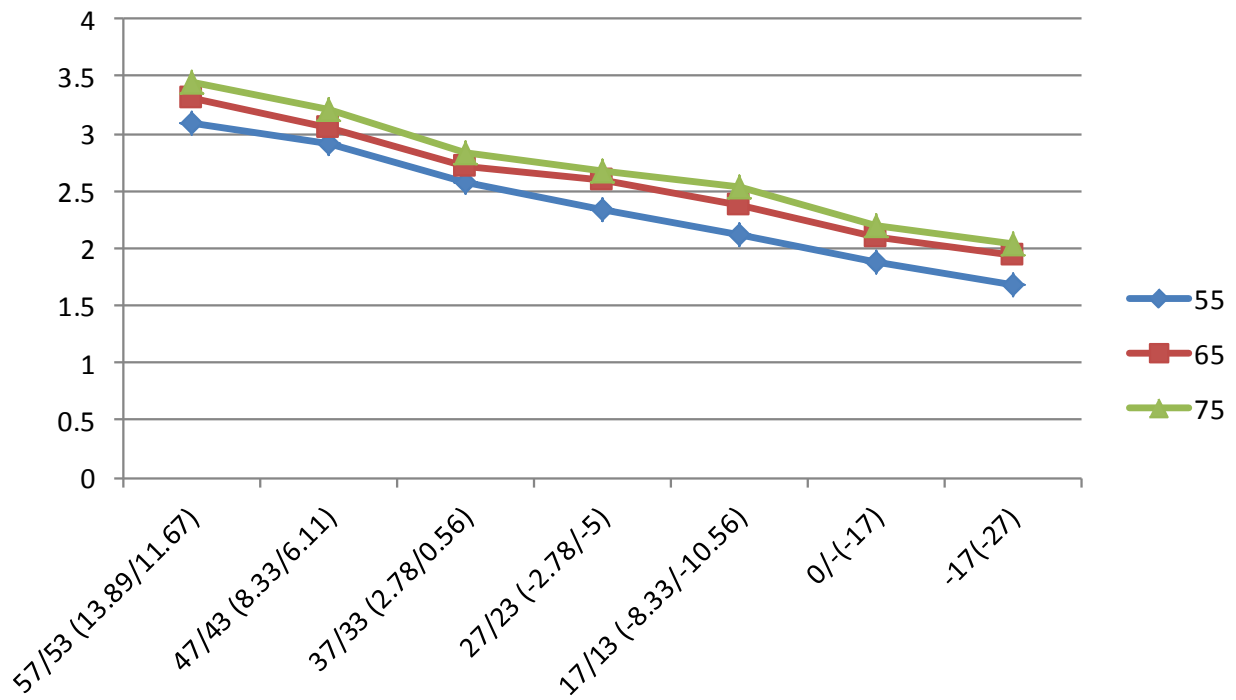

## System Pressure Table-R22

Pressure			Temperature		Pressure			Temperature	
Kpa	bar	PSI	°C	°F	Kpa	bar	PSI	°C	°F
100	1	14.5	-41.091	-41.964	1600	16	232	41.748	107.146
150	1.5	21.75	-32.077	-25.739	1650	16.5	239.25	43.029	109.452
200	2	29	-25.177	-13.319	1700	17	246.5	44.281	111.706
250	2.5	36.25	-19.508	-3.114	1750	17.5	253.75	45.506	113.911
300	3	43.5	-14.654	5.623	1800	18	261	46.706	116.071
350	3.5	50.75	-10.384	13.309	1850	18.5	268.25	47.882	118.188
400	4	58	-6.556	20.199	1900	19	275.5	49.034	120.261
450	4.5	65.25	-3.075	26.464	1950	19.5	282.75	50.164	122.295
500	5	72.5	0.124	32.223	2000	20	290	51.273	124.291
550	5.5	79.75	3.091	37.563	2050	20.5	297.25	52.361	126.250
600	6	87	5.861	42.550	2100	21	304.5	53.43	128.174
650	6.5	94.25	8.464	47.234	2150	21.5	311.75	54.48	130.064
700	7	101.5	10.92	51.656	2200	22	319	55.512	131.922
750	7.5	108.75	13.249	55.848	2250	22.5	326.25	56.527	133.749
800	8	116	15.465	59.837	2300	23	333.5	57.526	135.547
850	8.5	123.25	17.58	63.644	2350	23.5	340.75	58.508	137.314
900	9	130.5	19.604	67.287	2400	24	348	59.475	139.055
950	9.5	137.75	21.547	70.785	2450	24.5	355.25	60.427	140.769
1000	10	145	23.415	74.147	2500	25	362.5	61.364	142.455
1050	10.5	152.25	25.216	77.389	2550	25.5	369.75	62.288	144.118
1100	11	159.5	26.953	80.515	2600	26	377	63.198	145.756
1150	11.5	166.75	28.634	83.541	2650	26.5	384.25	64.095	147.371
1200	12	174	30.261	86.470	2700	27	391.5	64.98	148.964
1250	12.5	181.25	31.839	89.310	2750	27.5	398.75	65.852	150.534
1300	13	188.5	33.371	92.068	2800	28	406	66.712	152.082
1350	13.5	195.75	34.86	94.748	2850	28.5	413.25	67.561	153.610
1400	14	203	36.308	97.354	2900	29	420.5	68.399	155.118
1450	14.5	210.25	37.719	99.894	2950	29.5	427.75	69.226	156.607
1500	15	217.5	39.095	102.371	3000	30	435	70.042	158.076
1550	15.5	224.75	40.437	104.787					

## System Pressure Table-R410A

Pressure			Temperature		Pressure			Temperature	
Kpa	bar	PSI	°C	°F	Kpa	bar	PSI	°C	°F
100	1	14.5	-51.623	-60.921	2350	23.5	340.75	38.817	101.871
150	1.5	21.75	-43.327	-45.989	2400	24	348	39.68	103.424
200	2	29	-36.992	-34.586	2450	24.5	355.25	40.531	104.956
250	2.5	36.25	-31.795	-25.231	2500	25	362.5	41.368	106.462
300	3	43.5	-27.351	-17.232	2550	25.5	369.75	42.192	107.946
350	3.5	50.75	-23.448	-10.206	2600	26	377	43.004	109.407
400	4	58	-19.953	-3.915	2650	26.5	384.25	43.804	110.847
450	4.5	65.25	-16.779	1.798	2700	27	391.5	44.592	112.266
500	5	72.5	-13.863	7.047	2750	27.5	398.75	45.37	113.666
550	5.5	79.75	-11.162	11.908	2800	28	406	46.136	115.045
600	6	87	-8.643	16.444	2850	28.5	413.25	46.892	116.406
650	6.5	94.25	-6.277	20.701	2900	29	420.5	47.638	117.748
700	7	101.5	-4.046	24.716	2950	29.5	427.75	48.374	119.073
750	7.5	108.75	-1.933	28.521	3000	30	435	49.101	120.382
800	8	116	0.076	32.137	3050	30.5	442.25	49.818	121.672
850	8.5	123.25	1.993	35.587	3100	31	449.5	50.525	122.945
900	9	130.5	3.826	38.888	3150	31.5	456.75	51.224	124.203
950	9.5	137.75	5.584	42.052	3200	32	464	51.914	125.445
1000	10	145	7.274	45.093	3250	32.5	471.25	52.596	126.673
1050	10.5	152.25	8.901	48.022	3300	33	478.5	53.27	127.886
1100	11	159.5	10.471	50.848	3350	33.5	485.75	53.935	129.083
1150	11.5	166.75	11.988	53.578	3400	34	493	54.593	130.267
1200	12	174	13.457	56.223	3450	34.5	500.25	55.243	131.437
1250	12.5	181.25	14.879	58.782	3500	35	507.5	55.885	132.593
1300	13	188.5	16.26	61.268	3550	35.5	514.75	56.52	133.736
1350	13.5	195.75	17.602	63.684	3600	36	522	57.148	134.866
1400	14	203	18.906	66.031	3650	36.5	529.25	57.769	135.984
1450	14.5	210.25	20.176	68.317	3700	37	536.5	58.383	137.089
1500	15	217.5	21.414	70.545	3750	37.5	543.75	58.99	138.182
1550	15.5	224.75	22.621	72.718	3800	38	551	59.591	139.264
1600	16	232	23.799	74.838	3850	38.5	558.25	60.185	140.333
1650	16.5	239.25	24.949	76.908	3900	39	565.5	60.773	141.391
1700	17	246.5	26.074	78.933	3950	39.5	572.75	61.355	142.439
1750	17.5	253.75	27.174	80.913	4000	40	580	61.93	143.474
1800	18	261	28.251	82.852	4050	40.5	587.25	62.499	144.498
1850	18.5	268.25	29.305	84.749	4100	41	594.5	63.063	145.513
1900	19	275.5	30.338	86.608	4150	41.5	601.75	63.62	146.516
1950	19.5	282.75	31.351	88.432	4200	42	609	64.172	147.510
2000	20	290	32.344	90.219	4250	42.5	616.25	64.719	148.494
2050	20.5	297.25	33.319	91.974	4300	43	623.5	65.259	149.466
2100	21	304.5	34.276	93.697	4350	43.5	630.75	65.795	150.431
2150	21.5	311.75	35.215	95.387	4400	44	638	66.324	151.383
2200	22	319	36.139	97.050	4450	44.5	645.25	66.849	152.328
2250	22.5	326.25	37.047	98.685	4500	45	652.5	67.368	153.262
2300	23	333.5	37.939	100.290					

## System Pressure Table-R32

Pressure			Temperature		Pressure			Temperature	
Kpa	bar	PSI	°C	°F	Kpa	bar	PSI	°C	°F
100	1	14.5	-51.909	-61.436	1850	18.5	268.25	28.425	83.165
150	1.5	21.75	-43.635	-46.543	1900	19	275.5	29.447	85.005
200	2	29	-37.323	-35.181	1950	19.5	282.75	30.448	86.806
250	2.5	36.25	-32.15	-25.87	2000	20	290	31.431	88.576
300	3	43.5	-27.731	-17.916	2050	20.5	297.25	32.395	90.311
350	3.5	50.75	-23.85	-10.93	2100	21	304.5	33.341	92.014
400	4	58	-20.378	-4.680	2150	21.5	311.75	34.271	93.688
450	4.5	65.25	-17.225	0.995	2200	22	319	35.184	95.331
500	5	72.5	-14.331	6.204	2250	22.5	326.25	36.082	96.948
550	5.5	79.75	-11.65	11.03	2300	23	333.5	36.965	98.537
600	6	87	-9.150	15.529	2350	23.5	340.75	37.834	100.101
650	6.5	94.25	-6.805	19.752	2400	24	348	38.688	101.638
700	7	101.5	-4.593	23.734	2450	24.5	355.25	39.529	103.152
750	7.5	108.75	-2.498	27.505	2500	25	362.5	40.358	104.644
800	8	116	-0.506	31.089	2550	25.5	369.75	41.173	106.111
850	8.5	123.25	1.393	34.507	2600	26	377	41.977	107.559
900	9	130.5	3.209	37.777	2650	26.5	384.25	42.769	108.984
950	9.5	137.75	4.951	40.911	2700	27	391.5	43.55	110.39
1000	10	145	6.624	43.923	2750	27.5	398.75	44.32	111.776
1050	10.5	152.25	8.235	46.823	2800	28	406	45.079	113.142
1100	11	159.5	9.790	49.621	2850	28.5	413.25	45.828	114.490
1150	11.5	166.75	11.291	52.324	2900	29	420.5	46.567	115.821
1200	12	174	12.745	54.941	2950	29.5	427.75	47.296	117.133
1250	12.5	181.25	14.153	57.475	3000	30	435	48.015	118.427
1300	13	188.5	15.52	59.936	3050	30.5	442.25	48.726	119.707
1350	13.5	195.75	16.847	62.325	3100	31	449.5	49.428	120.970
1400	14	203	18.138	64.648	3150	31.5	456.75	50.121	122.218
1450	14.5	210.25	19.395	66.911	3200	32	464	50.806	123.451
1500	15	217.5	20.619	69.114	3250	32.5	471.25	51.482	124.668
1550	15.5	224.75	21.813	71.263	3300	33	478.5	52.15	125.87
1600	16	232	22.978	73.360	3350	33.5	485.75	52.811	127.060
1650	16.5	239.25	24.116	75.409	3400	34	493	53.464	128.235
1700	17	246.5	25.229	77.412	3450	34.5	500.25	54.11	129.398
1750	17.5	253.75	26.317	79.371	3500	35	507.5	54.748	130.546
1800	18	261	27.382	81.288					