



SERVICE MANUAL

Master Model Numbers

DM12HIW42230E4
DM09HIW42230E4
DM09HOS42230E4
DM12HOS42230E4
DM24HOS25230E3A
DM36HOS25230E3

Product code

22022011011639
22022011011638
22022016011279
22022016011280
22022016015920
22023016002671

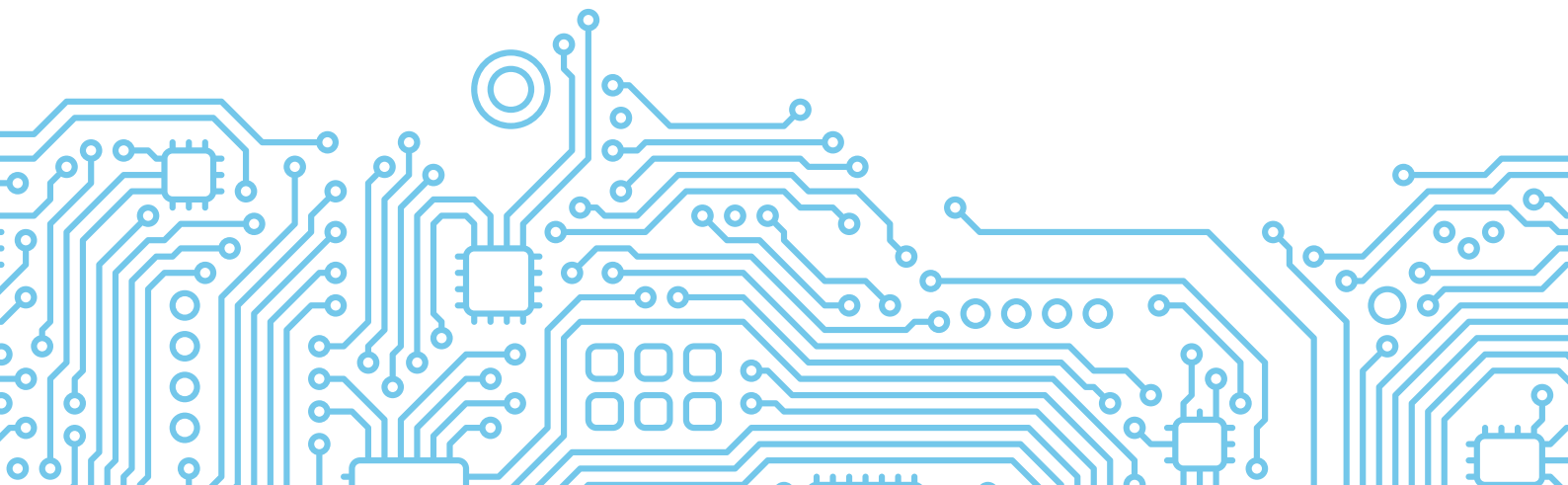
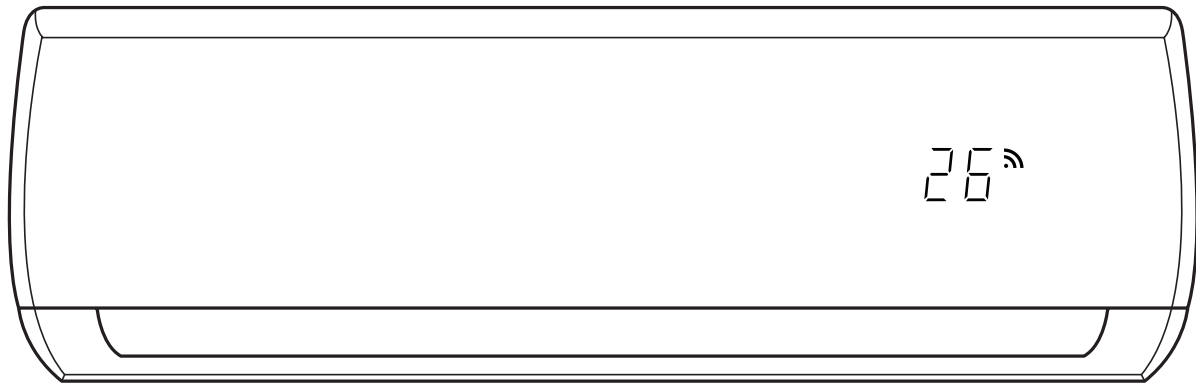

Table of Contents

Page

1. Safety Precautions	1
1. In case of Accidents or Emergency	
2. Pre-Installation and Installation	
3. Operation and Maintenance	
2. Specifications	4
1. Model Reference	
2. Electrical Wiring Diagrams	
3. Product Features	9
1. Operation Modes and Functions	
4. Maintenance and Disassembly	16
1. Maintenance	
2. Disassembly	
5. Troubleshooting	45
1. Safety Caution	
2. General Troubleshooting	
3. Error Diagnosis and Troubleshooting Without Error Code	
4. Quick Maintenance by Error Code	
5. Troubleshooting by Error Code	
Appendix	77
i) Temperature Sensor Resistance Value Table for T1,T2,T3 and T4 (°C – K)	
ii) Temperature Sensor Resistance Value Table for TP (°C – K)	
iii) $\Delta T(^{\circ}F)=(9\Delta T(^{\circ}C))/5+32$	
iv) Pressure On Service Port	
v) Temperature Humidity Characteristics	

Safety Precautions

Contents

1.	In Case of Accidents or Emergency	2
2.	Pre-Installation.....	2
3.	Operation and Maintenance.....	2

To prevent personal injury, or property or unit damage, adhere to all precautionary measures and instructions outlined in this manual. Before servicing a unit, refer to this service manual and its relevant sections.

Failure to adhere to all precautionary measures listed in this section may result in personal injury, damage to the unit or to property, or in extreme cases, death.

 **WARNING** indicates a potentially hazardous situation which if not avoided could result in serious personal injury, or death.

 **CAUTION** indicates a potentially hazardous situation which if not avoided could result in minor or moderate personal injury, or unit damage.

1. In case of Accidents or Emergency

 **WARNING**

- If a gas leak is suspected, immediately turn off the gas and ventilate the area if a gas leak is suspected before turning the unit on.
- If strange sounds or smoke is detected from the unit, turn the breaker off and disconnect the power supply cable.
- If the unit comes into contact with liquid, contact an authorized service center.
- If liquid from the batteries makes contact with skin or clothing, immediately rinse or wash the area well with clean water.
- Do not insert hands or other objects into the air inlet or outlet while the unit is plugged in.
- Do not operate the unit with wet hands.
- Do not use a remote controller that has previously been exposed to battery damage or battery leakage.

 **CAUTION**

- Clean and ventilate the unit at regular intervals when operating it near a stove or near similar devices.
- Do not use the unit during severe weather conditions. If possible, remove the product from the window before such occurrences.

2. Pre-Installation and Installation

 **WARNING**

- Use this unit only on a dedicated circuit.
- Damage to the installation area could cause the unit to fall, potentially resulting in personal injury, property damage, or product failure.
- Only qualified personnel should disassemble, install, remove, or repair the unit.
- Only a qualified electrician should perform electrical work. For more information, contact your dealer, seller, or an authorized service center.

 **CAUTION**

- While unpacking be careful of sharp edges around the unit as well as the edges of the fins on the condenser and evaporator.

3. Operation and Maintenance

 **WARNING**

- Do not use defective or under-rated circuit breakers.
- Ensure the unit is properly grounded and that a dedicated circuit and breaker are installed.
- Do not modify or extend the power cable. Ensure the power cable is secure and not damaged during operation.
- Do not unplug the power supply plug during operation.
- Do not store or use flammable materials near the unit.
- Do not open the inlet grill of the unit during operation.
- Do not touch the electrostatic filter if the unit is equipped with one.
- Do not block the inlet or outlet of air flow to the unit.
- Do not use harsh detergents, solvents, or similar items to clean the unit. Use a soft cloth for cleaning.
- Do not touch the metal parts of the unit when removing the air filter as they are very sharp.
- Do not step on or place anything on the unit or outdoor units.
- Do not drink water drained from the unit
- Avoid direct skin contact with water drained from the unit.
- Use a firm stool or step ladder according to manufacturer procedures when cleaning or maintaining the unit.

 **CAUTION**

- Do not install or operate the unit for an extended period of time in areas of high humidity or in an environment directly exposing it to sea wind or salt spray.
- Do not install the unit on a defective or damaged installation stand, or in an unsecure location.
- Ensure the unit is installed at a level position
- Do not install the unit where noise or air discharge created by the outdoor unit will negatively impact the environment or nearby residences.
- Do not expose skin directly to the air discharged by the unit for prolonged periods of time.
- Ensure the unit operates in areas water or other liquids.
- Ensure the drain hose is installed correctly to ensure proper water drainage.
- When lifting or transporting the unit, it is recommended that two or more people are used for this task.
- When the unit is not to be used for an extended time, disconnect the power supply or turn off the breaker.

Specifications

Contents

1.	Model Reference	4
2.	Electrical Wiring Diagrams	5
2.1	Indoor Unit.....	5
2.2	Outdoor Unit.....	7

- to be surveyed to make sure that there are no flammable

1. Model Reference

Refer to the following table to determine the specific indoor and outdoor unit model number of your purchased

Indoor Unit Model	Master Indoor Unit Model	Product code	Outdoor Unit Model	Master Outdoor Unit Model	Product code	Capacity (Btu)	Power Supply
MSOP1B-09HRFN1-MZA5W	DM09HIW42230E4	22022011011638	MOCA30-09HFN1-MZA5W	DM09HOS42230E4	22022016011279	9k	208-230V~, 60Hz, 1Phase
MSOP1B-12HRFN1-MZ50W	DM12HIW42230E4	22022011011639	MOCA30-12HFN1-MZ50W	DM12HOS42230E4	22022016011280	12k	

2. Electrical Wiring Diagrams

2.1 Indoor unit

Abbreviation	Paraphrase
Y/G	Yellow-Green Conductor
ION	Positive and Negative Ion Generator
CAP	Capacitor
PLASMA	Electronic Dust Collector
L	LIVE
N	NEUTRAL
Heater	The Electric Heating Belt of Indoor Unit
T1	Indoor Room Temperature
T2	Coil Temperature of Indoor Heat Exchanger Middle

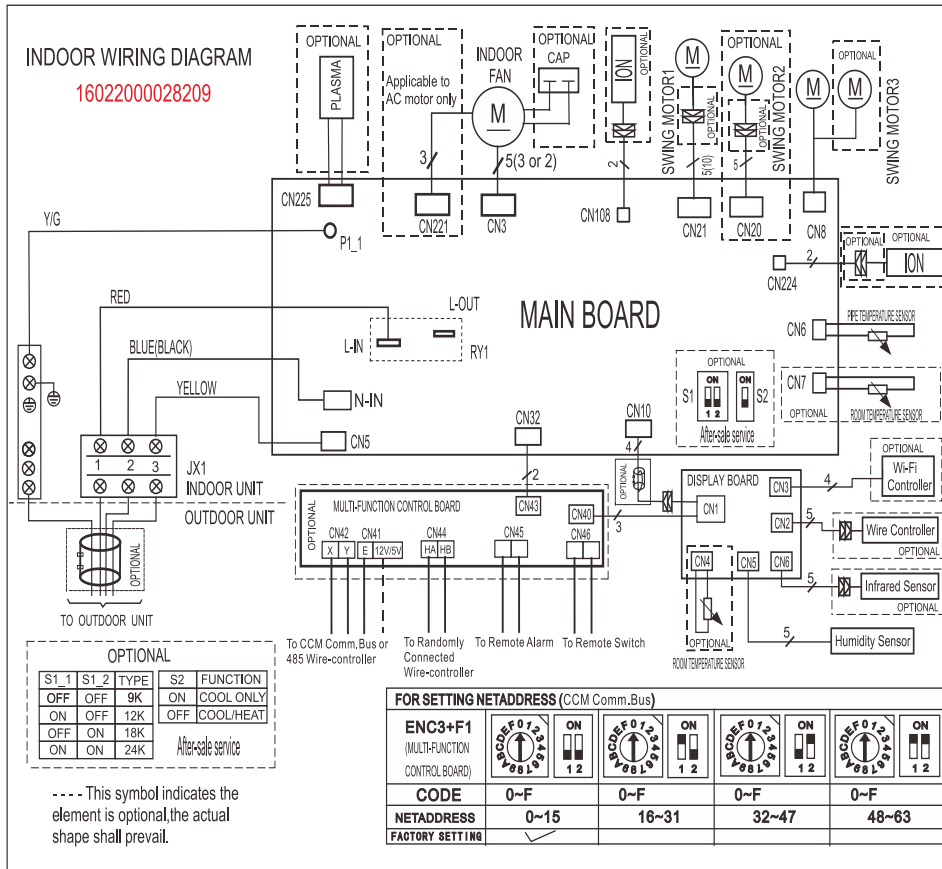

2.2 Outdoor Unit

Abbreviation	Paraphrase
4-WAY	Gas Valve Assembly/4-WAY VALVE
AC-FAN	Alternating Current FAN
DC-FAN	Direct Current FAN
CT1	AC Current Detector
COMP	Compressor
L-PRO	Low Pressure Switch
H-PRO	High Pressure Switch
T3	Coil Temperature of Condenser
T4	Outdoor Ambient Temperature
TH	Compressor Suction Temperature
TP	Compressor Discharge Temperature
EEV	Electronic expansion valve

MOCA30-09HFN1-MZA5W, MOCA30-12HFN1-MZ50W

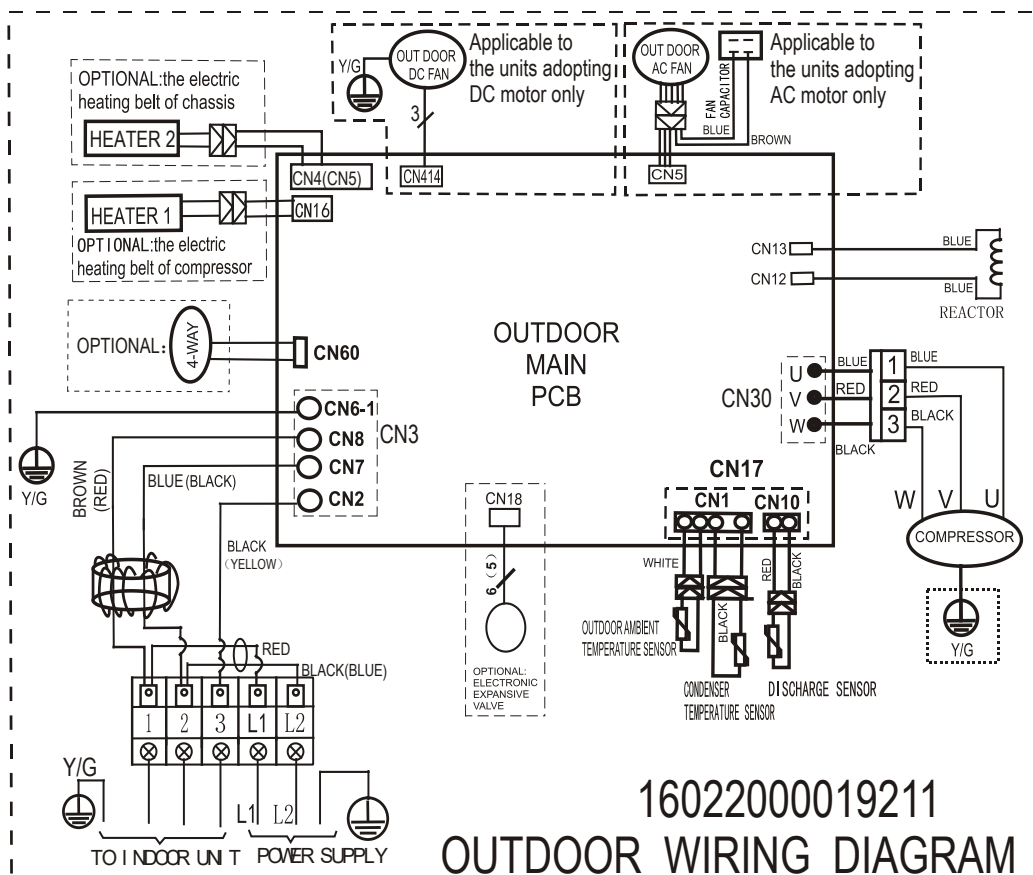

PCB board of MOCA30-09HFN1-MZA5W, MOCA30-12HFN1-MZ50W

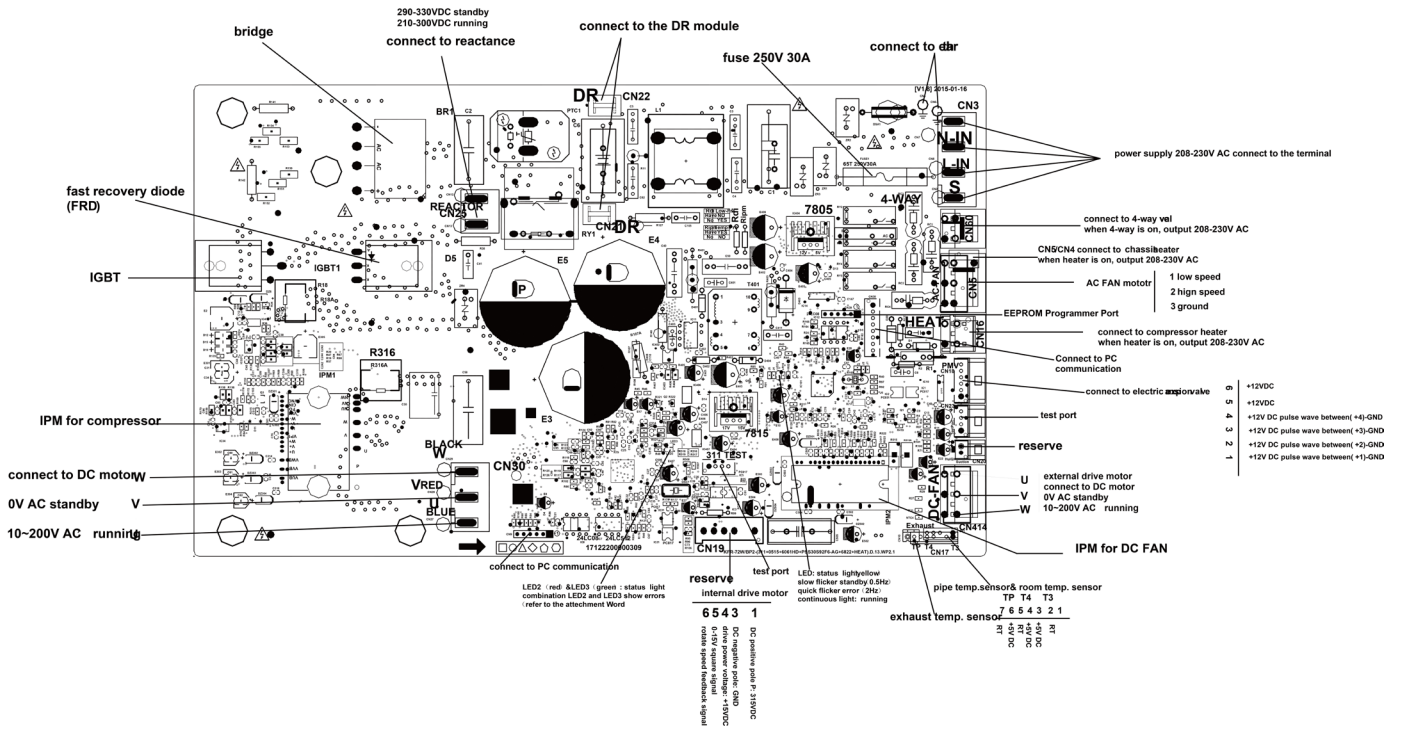

Product Features

Contents

1.	Operation Modes and Functions	10
1.1	Abbreviation.....	10
1.2	Safety Features	10
1.3	Display Function	10
1.4	Fan Mode.....	11
1.5	Cooling Mode	11
1.6	Heating mode	11
1.7	Auto-mode.....	12
1.8	Drying Mode	12
1.9	Forced Operation Function	13
1.10	Timer Function	13
1.11	Sleep Function.....	13
1.12	Auto-Restart Function.....	13
1.13	8°C Heating	13
1.14	ECO Function	13
1.15	Self Clean(Optional).....	14
1.16	Follow Me(Optional)	14
1.17	Silence (Optional).....	14
1.18	Intelligent Eye (Optional).....	14
1.19	Information Inquiry.....	14

1. Operation Modes and Functions

1.1 Abbreviation

Unit element abbreviations

Abbreviation	Element
T1	Indoor room temperature
T2	Coil temperature of evaporator
T3	Coil temperature of condenser
T4	Outdoor ambient temperature
Tsc	Adjusted setting temperature
TP	Compressor discharge temperature

1.2 Safety Features

Compressor three-minute delay at restart

Compressor functions are delayed for up to ten seconds upon the first startup of the unit, and are delayed for up to three minutes upon subsequent unit restarts.

Automatic shutoff based on discharge temperature

If the compressor discharge temperature exceeds 108°C for nine seconds, the compressor ceases operation.

Automatic shutoff based on fan speed

If the indoor fan speed registers below 300RPM or over 1500RPM for an extended period of time, the unit ceases operation and the corresponding error code is displayed on the indoor unit.

Inverter module protection

The inverter module has an automatic shutoff mechanism based on the unit's current, voltage, and temperature. If automatic shutoff is initiated, the corresponding error code is displayed on the indoor unit and the unit ceases operation.

Indoor fan delayed operation

- When the unit starts, the louver is automatically activated and the indoor fan will operate after a period of setting time or the louver is in place.
- If the unit is in heating mode, the indoor fan is regulated by the anti-cold wind function.

Compressor preheating

Preheating is automatically activated when T4 sensor is lower than setting temperature.

Sensor redundancy and automatic shutoff

- If one temperature sensor malfunctions, the air

conditioner continues operation and displays the corresponding error code, allowing for emergency use.

- When more than one temperature sensor is malfunctioning, the air conditioner ceases operation.

1.3 Display Function

Unit display functions



Function	Display
Temperature	Set temperature value
Temperature (fan and Drying mode)	Room temperature
Activation of Timer ON, Fresh, Swing, Turbo, or Silent	ON (3s)
Cancellation of Timer OFF, Fresh, Swing, Turbo, or Silent	OF (3s)
Defrost	df
Warming in heating mode	cf
Self-clean (available on select units only)	SC
Heating in room temperature under 8°C or 12°C	FP
Fresh(available on select units only)	Leaf icon
ECO function (available on select units only)	eco
WiFi control (available on select units only)	WiFi symbol
The current operation power(available on select units only)	kW

1.4 Fan Mode

When fan mode is activated:

- The outdoor fan and compressor are stopped.
- Temperature control is disabled and indoor room temperature is displayed.
- The indoor fan speed can be set to 1%~100%, or auto.
- The louver operations are identical to those in cooling mode.
- Auto fan: In fan-only mode, AC operates the same as auto fan in cooling mode with the temperature set at 24°C.(Tsc =24°C)

1.5 Cooling Mode

1.5.1 Compressor Control

Reach the configured temperature:

- 1) When the compressor runs continuously for less than 120 minutes.
 - If the following conditions are satisfied, the compressor ceases operation.
 - While calculated frequency(fb) is less than minimum limit frequency(FminC).
 - While protective time is more than or equal to ten minutes.
 - While T1 is lower than or equal to (Tsc-CDIFTEMP-0.5°C)
- Note: CDIFTEMP is EEPROM setting parameter. It is 2°C usually.
- 2) When the compressor runs continuously for more than 120 minutes.
 - If the following conditions are satisfied, the compressor ceases operation.
 - When calculated frequency(fb) is less than minimum limit frequency(FminC).
 - When protective time is more than or equal to ten minutes.
 - When T1 is lower than or equal to (Tsc-CDIFTEMP).
- Note: CDIFTEMP is EEPROM setting parameter. It is 2°C usually.
- 3) If one of the following conditions is satisfied, not judge protective time.
 - Compressor running frequency is more than test frequency.
 - When compressor running frequency is equal to test frequency, T4 is more than 15°C or no T4 or T4

fault.

- Change setting temperature.
- Turbo or sleep function on/off
- Various frequency limit shutdown occurs.

Note: CDIFTEMP is EEPROM setting parameter. It is 2°C usually.

1.5.2 Indoor Fan Control

- 1) In cooling mode, the indoor fan operates continuously. The fan speed can be set to 1%-100%, or auto.
- 2) Auto fan
 - Descent curve
 - When T1-Tsc is lower than or equal to 3.5°C, fan speed reduces to 80%;
 - -When T1-Tsc is lower than or equal to 1°C, fan speed reduces to 60%;
 - -When T1-Tsc is lower than or equal to 0.5°C, fan speed reduces to 40%;
 - -When T1-Tsc is lower than or equal to 0°C, fan speed reduces to 20%;
 - -When T1-Tsc is lower than or equal to -0.5°C, fan speed reduces to 1%.
 - Rise curve
 - When T1-Tsc is higher than 0°C, fan speed increases to 20%;
 - -When T1-Tsc is higher than 0.5°C, fan speed increases to 40%;
 - -When T1-Tsc is higher than 1°C, fan speed increases to 60%;
 - -When T1-Tsc is higher than 1.5°C, fan speed increases to 80%;
 - -When T1-Tsc is higher than 4°C, fan speed increases to 100%.

1.5.3 Outdoor Fan Control

- The outdoor unit will be run at different fan speed according to T4 and compressor running frequency..
- For different outdoor units, the fan speeds are different.

1.5.4 Condenser Temperature Protection

When the condenser temperature exceeds a configured value, the compressor ceases operations.

1.5.5 Evaporator Temperature Protection

When evaporator temperature drops below a configured value, the compressor and outdoor fan ceases operations.

1.6 Heating Mode

1.6.1 Compressor Control

- 1) Reach the configured temperature
 - If the following conditions are satisfied, the compressor ceases operation.
 - While calculated frequency(fb) is less than minimum limit frequency(FminC).
 - When protective time is more than or equal to ten minutes.
 - When T1 is higher than or equal to Tsc+ HDIFTEMP2.

Note: HDIFTEMP2 is EEPROM setting parameter. It is 2°C usually.

- If one of the following conditions is satisfied, not judge protective time.
 - Compressor running frequency is more than test frequency.
 - When compressor running frequency is equal to test frequency, T4 is more than 15°C or no T4 or T4 fault.
 - Change setting temperature.
 - Turbo or sleep function on/off.
- 2) When the current is higher than the predefined safe value, surge protection is activated, causing the compressor to cease operations.

1.6.2 Indoor Fan Control:

- 1) In heating mode, the indoor fan operates continuously. The fan speed can be set to 1%-100%, or mute.
- 2) Auto fan
 - Rise curve
 - When T1-Tsc is higher than -1.5°C, fan speed reduces to 80%;
 - -When T1-Tsc is higher than 0°C, fan speed reduces to 60%;
 - -When T1-Tsc is higher than 0.5°C, fan speed reduces to 40%;
 - -When T1-Tsc is higher than 1°C, fan speed reduces to 20%.
 - Descent curve
 - When T1-Tsc is lower than or equal to 0.5°C, fan speed increases to 20%;
 - -When T1-Tsc is lower than or equal to 0°C, fan speed increases to 60%;
 - -When T1-Tsc is lower than or equal to -1.5°C, fan speed increases to 80%;
 - -When T1-Tsc is lower than or equal to -3°C, fan speed increases to 100%.

1.6.3 Outdoor Fan Control:

- The outdoor unit will be run at different fan speed according to T4 and compressor running frequency.
- For different outdoor units, the fan speeds are different.

1.6.4 Defrosting mode

- The unit enters defrosting mode according to changes in the temperature value of T3, T4 as well as the compressor running time.
- In defrosting mode, the compressor continues to run, the indoor and outdoor motor will cease operation, the defrost light of the indoor unit will turn on, and the "df" symbol is displayed.
- If any one of the following conditions is satisfied, defrosting ends and the machine switches to normal heating mode:
 - T3 rises above TCDE1°C.
 - T3 maintained above TCDE2°C for 80 seconds.
 - Unit runs for 15 minutes consecutively in defrosting mode.

1.6.5 Evaporator Temperature Protection

When the evaporator temperature exceeds a preset protection value, the compressor ceases operation.

1.7 Auto-mode

- This mode can be selected with the remote controller and the setting temperature can be changed between 16°C~30°C.
- In auto mode, the machine selects cooling, heating, auto-drying or fan-only mode on the basis of T1, Ts, T4 and relative humidity.
- If the setting temperature is modified, the machine selects a new running function.

1.8 Drying mode

In drying mode, AC operates the same as auto fan in cooling mode.

- 1) Mute function is active.
 - All protections are activated and operate the same as they do that in cooling mode.
- 2) Low Room Temperature Protection
 - If the room temperature is lower than 10°C, the compressor ceases operations and does not resume until room temperature exceeds 12°C.

1.9 Forced operation function

- Forced cooling mode:

The compressor and outdoor fan continue to run and the indoor fan runs at rated speed. After running for 30 minutes, the AC will switch to auto mode with a preset temperature of 24°C.

- Forced auto mode:

Forced auto mode operates the same as normal auto mode with a preset temperature of 24°C.

- The unit exits forced operation when it receives the following signals:
 - Switch on
 - Switch off
 - Timer on
 - Timer off
- Changes in:
 - mode
 - fan speed
 - setting temperature

1.10 Timer function

- Timing range is 24 hours.
- Timer on. The machine will turn on automatically when reaching the setting time.
- Timer off. The machine will turn off automatically when reaching the setting time.
- Timer on/off. The machine will turn on automatically when reaching the setting "on" time, and then turn off automatically when reaching the setting "off" time.
- Timer off/on. The machine will turn off automatically when reaching the setting "off" time, and then turn on automatically when reaching the setting "on" time.
- The timer function will not change the AC current operation mode. Suppose AC is off now, it will not start up firstly after setting the "timer off" function. And when reaching the setting time, the timer LED will be off and the AC running mode has not been changed.
- The setting time is relative time.
- The AC will quit the timer function when it has malfunction

1.11 Sleep function

- The sleep function is available in cooling, heating, or auto mode.
- The operational process for sleep mode is as follows:

- When cooling, the temperature rises 1°C (to not higher than 30°C) every hour. After 2 hours, the temperature stops rising and the indoor fan is fixed at low speed.
- When heating, the temperature decreases 1°C (to not lower than 16°C) every hour. After 2 hours, the temperature stops decreasing and the indoor fan is fixed at low speed. Anti-cold wind function takes priority.
- The operating time for sleep mode is 8 hours, after which, the unit exits this mode and switches off.
- The timer setting is available in this mode.

1.12 Auto-Restart function

- The indoor unit has an auto-restart module that allows the unit to restart automatically. The module automatically stores the current settings and, in the case of a sudden power failure, will restore those setting automatically within 3 minutes after power returns.
- If there is a power failure while the unit is running, the compressor starts 3 minutes after the unit restarts. If the unit was already off before the power failure, the unit stands by.

1.13 8°C Heating

In heating mode, the temperature can be set to as low as 8°C, preventing the indoor area from freezing if unoccupied during severe cold weather.

1.14 ECO function

- Used to enter the energy efficient mode.
 - Under cooling mode, press ECO button, the remote controller will adjust the temperature automatically to 24°C, fan speed of Auto to save energy (but only if the set temperature is less than 24°C). If the set temperature is more than 24°C and 30°C, press the ECO button, the fan speed will change to Auto, the set temperature will remain unchanged.
- When AC receives signals, such as switch off, Turbo operation, Silence operation, Self clean operation, Forced cooling operation, mode setting, Sleeping mode, or adjusting the set temperature to less than 24°C, it will quit the ECO operation.
- Operation time in ECO mode is 8 hours. After 8 hours the AC quits this mode.
- When there's any one temperature sensor in malfunction, the AC will quit ECO mode.
- Indoor fan will run at auto fan when enter into the ECO mode. The setting temperature and setting fan

speed can be changed through remote controller signal.

1.15 Self clean(Optional)

- The indoor unit will run at low fan for 16 minutes, then turn off, if you press "Self Clean" when the unit is in cooling or drying mode.
- Self Clean keeps the indoor unit dry and prevents mold growth.

1.16 Follow me(Optional)

- If you press "Follow Me" on the remote, the indoor unit will beep. This indicates the follow me function is active.
- Once active, the remote control will send a signal every 3 minutes, with no beeps. The unit automatically sets the temperature according to the measurements from the remote control.
- The unit will only change modes if the information from the remote control makes it necessary, not from the unit's temperature setting.
- If the unit does not receive a signal for 7 minutes or you press "Follow Me," the function turns off. The unit regulates temperature based on its own sensor and settings.

1.17 Silence (Optional)

Press "Silence" on the remote control to enable the

SILENCE function. While this function is active, the indoor unit will run at faint breeze(1% fan speed), which reduces noise to the lowest possible level.

1.18 Intelligent Eye (Optional)

With the built-in infrared sensor, the indoor unit detects human movement. If the compressor operates in high frequency, you leave the room for 30 minutes, the compressor operates in lower frequency. Then you don't come back for over 90 minutes, the compressor operates in the lowest frequency. If the compressor operates in medium frequency, you leave the room over 120 minutes, the compressor operates in lowest frequency. The compressor resumes automatically when you come back.

1.19 Information Inquiry

To enter information inquiry status, complete the following procedure within ten seconds:

- Press LED 3 times.
- Press SWING 3 times.
- If you are successful, you will hear beeps for two seconds.
- Use the LED and SWING buttons to cycle through information displayed.
- Pressing LED will display the next code in the sequence. Pressing SWING will show the previous.

The table shows information codes. The screen will display this code for two seconds, then the information for 25 seconds.

Displayed code	Explanation	Additional Notes
T1	T1	T1 temperature
T2	T2	T2 temperature
T3	T3	T3 temperature
T4	T4	T4 temperature
TP	TP	TP temperature
Targeted frequency	FT	Targeted Frequency
Actual frequency	TR	Actual Frequency
Compressor current	DL	N/A
Outdoor AC voltage	UO	N/A
Indoor capacity test	SN	N/A
Reserve	--	Running mode
Outdoor fan speed	PR	Outdoor fan speed
EXV opening angle	LR	EXV opening angle
Indoor fan speed	IR	Indoor fan speed
Indoor humidity	HU	N/A
Adjusted setting temperature	TT	N/A
Indoor dust concentrations	DT	N/A
WIFI signal strength	IF	N/A
GA algorithm frequency	OT	N/A

Maintenance and Disassembly

Contents

1. Maintenance	17
1.1 First Time Installation Check	17
1.2 Refrigerant Recharge	19
1.3 Re-Installation	20
1.3.1 Indoor Unit	20
1.3.2 Outdoor Unit	22
2. Disassembly	24
2.1 Indoor Unit.....	24
2.2 Outdoor Unit.....	35

1. Maintenance

1.1 First Time Installation Check

Air and moisture trapped in the refrigerant system affects the performance of the air conditioner by:

- Increasing pressure in the system.
- Increasing the operating current.
- Decreasing the cooling or heating efficiency.
- Congesting the capillary tubing due to ice build-up in the refrigerant circuit.
- Corroding the refrigerant system.

To prevent air and moisture from affecting the air conditioner's performance, the indoor unit, as well as the pipes between the indoor and outdoor unit, must be leak tested and evacuated.

Leak test (soap water method)

Use a soft brush to apply soapy water or a neutral liquid detergent onto the indoor unit connections and outdoor unit connections. If there is gas leakage, bubbles will form on the connection.

Air purging with vacuum pump

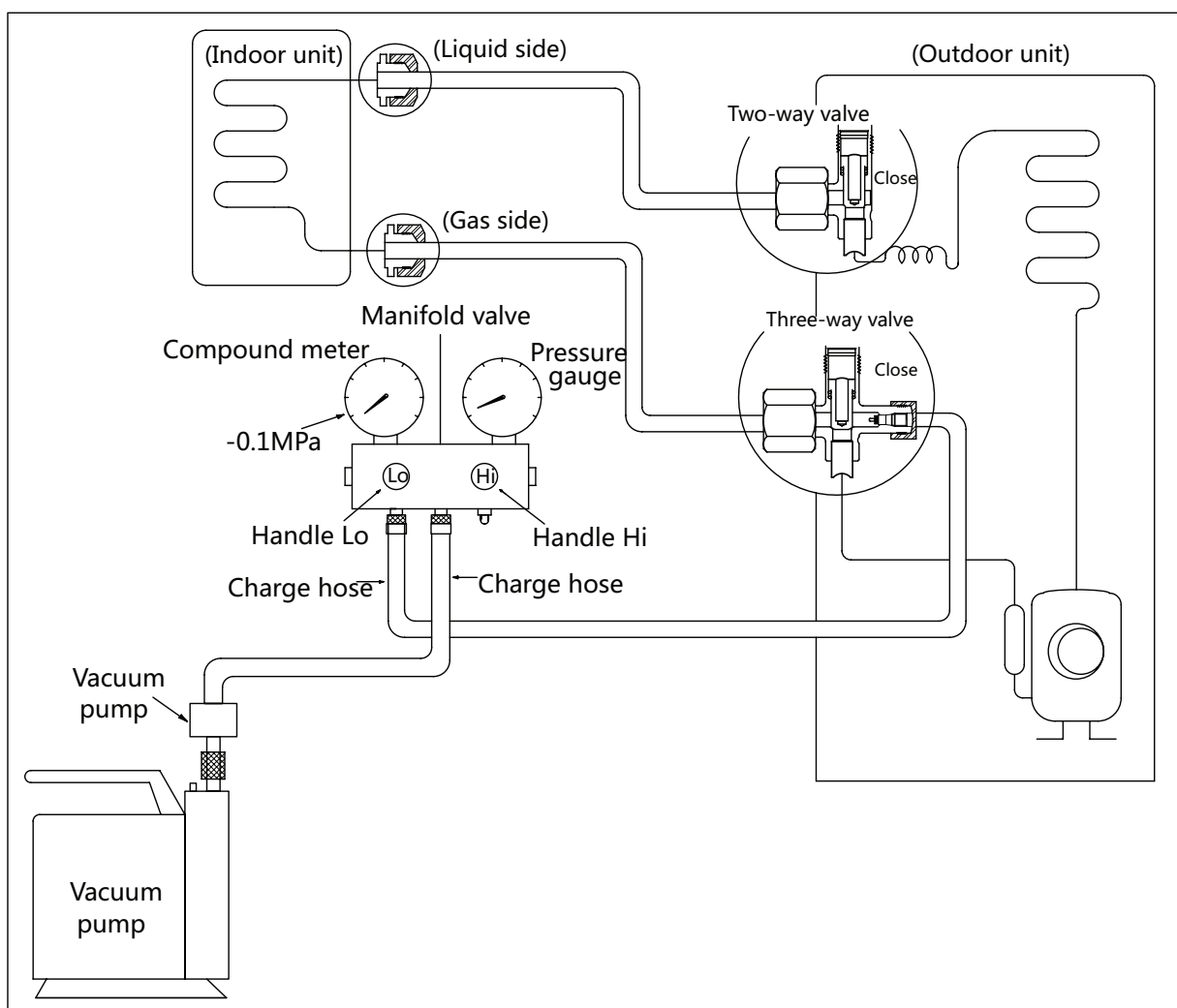

Procedure:

1. Tighten the flare nuts of the indoor and outdoor units, and confirm that both the 2- and 3-way valves are closed.
2. Connect the charge hose with the push pin of Handle Lo to the gas service port of the 3-way valve.
3. Connect another charge hose to the vacuum pump.
4. Fully open the Handle Lo manifold valve.
5. Using the vacuum pump, evacuate the system for 30 minutes.
 - a. Check whether the compound meter indicates -0.1 MPa (14.5 Psi).
 - If the meter does not indicate -0.1 MPa (14.5 Psi) after 30 minutes, continue evacuating for an additional 20 minutes.
 - If the pressure does not achieve -0.1 MPa (14.5 Psi) after 50 minutes, check for leakage.
 - b. If the pressure successfully reaches -0.1 MPa (14.5 Psi), fully close the Handle Lo valve, then cease vacuum pump operations.
6. Wait for 5 minutes then check whether the gauge needle moves after turning off the vacuum pump. If the gauge needle moves backwards, check whether there is gas leakage.
 - a. Loosen the flare nut of the 3-way valve for 6 or 7 seconds and then tighten the flare nut again.
 - a. Confirm the pressure display in the pressure indicator is slightly higher than the atmospheric pressure.
 - b. Remove the charge hose from the 3-way valve.
7. Fully open the 2- and 3-way valves and tighten the cap of the 2- and 3-way valve.

1.2 Refrigerant Recharge

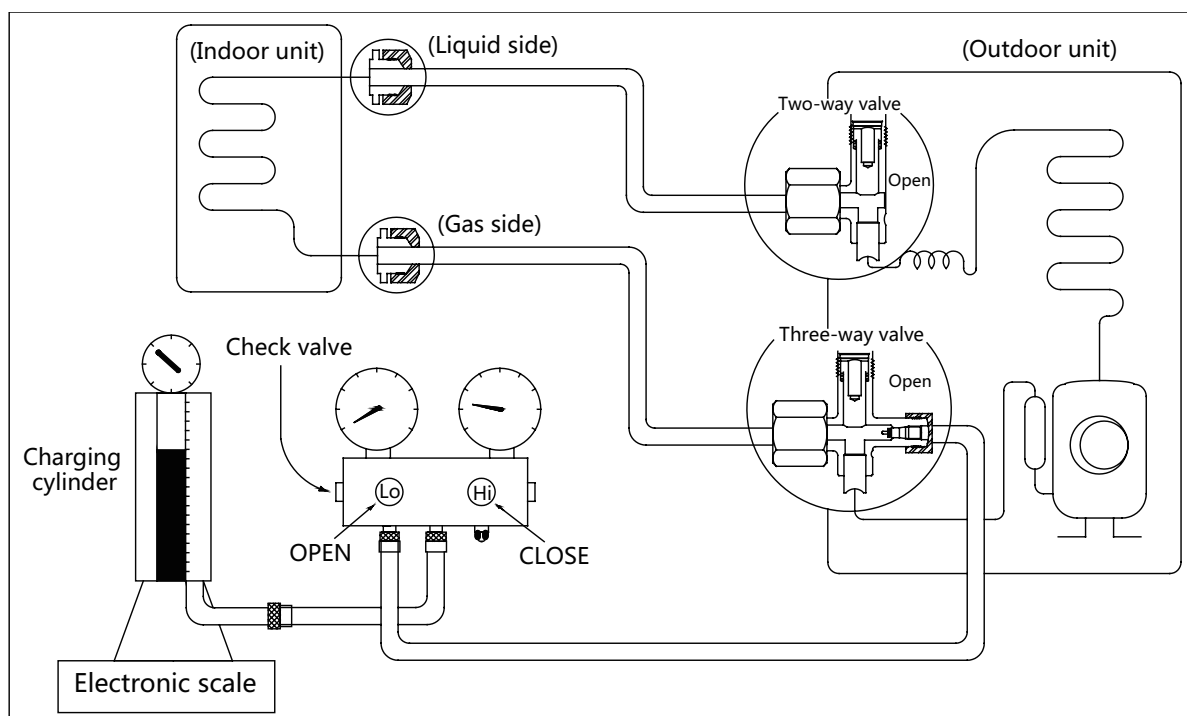

Prior to recharging the refrigerant, confirm the additional amount of refrigerant required using the following table:

Models	Standard length	Max. elevation	Max. length	Additional refrigerant
9k&12k	7.5m (24.6ft)	10m (32.8ft)	25m (82.0ft)	15g/m (0.16oz/ft)

Procedure:

1. Tighten the flare nuts of the indoor and outdoor units, and confirm that both the 2- and 3-way valves are closed.
2. Slightly connect the Handle Lo charge hose to the 3-way service port.
3. Connect the charge hose to the valve at the bottom of the cylinder.
If the refrigerant is R410A, invert the cylinder to ensure a complete liquid charge.
4. Partially open the Handle Lo manifold valve.
5. Open the valve at the bottom of the cylinder for 5 seconds to purge the air in the charge hose, then fully tighten the charge hose with the push pin of Handle Lo to the gas service port of the 3-way valve.
6. Place the charging cylinder onto an electronic scale and record the starting weight.
7. Fully open the Handle Lo manifold valve, 2- and 3-way valves.
8. Operate the air conditioner in cooling mode and charge the system with liquid refrigerant.
9. When the electronic scale displays the correct weight (refer to the gauge and the pressure of the low side to confirm), turn off the air conditioner, then disconnect the charge hose from the 3-way service port immediately..
10. Mount the caps of service port and 2- and 3-way valves.
11. Use a torque wrench to tighten the caps to a torque of 18N.m.
12. Check for gas leakage.

1.3 Re-Installation

1.3.1 Indoor Unit

Collecting the refrigerant into the outdoor unit

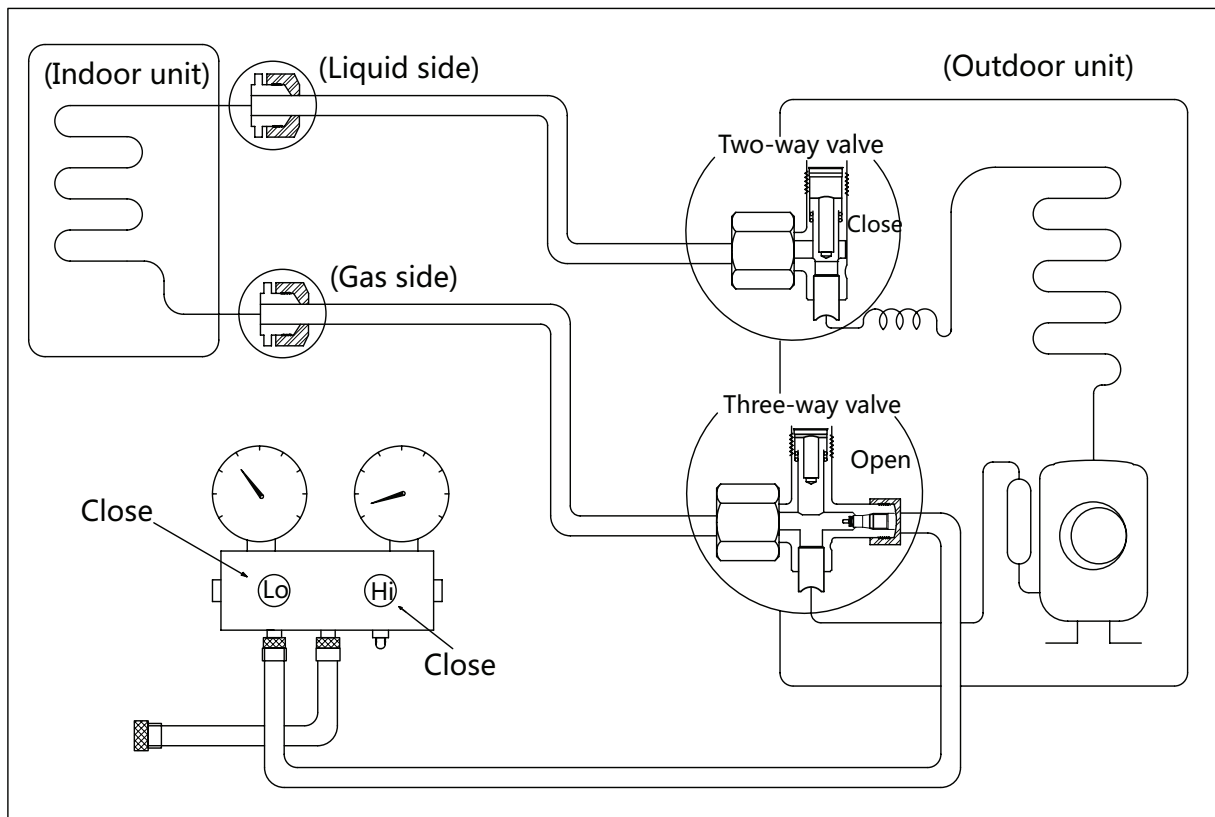

Procedure:

1. Confirm that the 2- and 3-way valves are opened.
2. Connect the charge hose with the push pin of Handle Lo to the 3-way valve's gas service port.
3. Open the Handle Lo manifold valve to purge air from the charge hose for 5 seconds and then close it quickly.
4. Close the 2-way valve.
5. Operate the air conditioner in cooling mode. Cease operations when the gauge reaches 0.1 MPa (14.5 Psi).
6. Close the 3-way valve so that the gauge rests between 0.3 MPa (43.5 Psi) and 0.5 MPa (72.5 Psi).
7. Disconnect the charge set and mount the caps of service port and 2- and 3-way valves.
8. Use a torque wrench to tighten the caps to a torque of 18N.m.
9. Check for gas leakage.

Air purging with vacuum pump

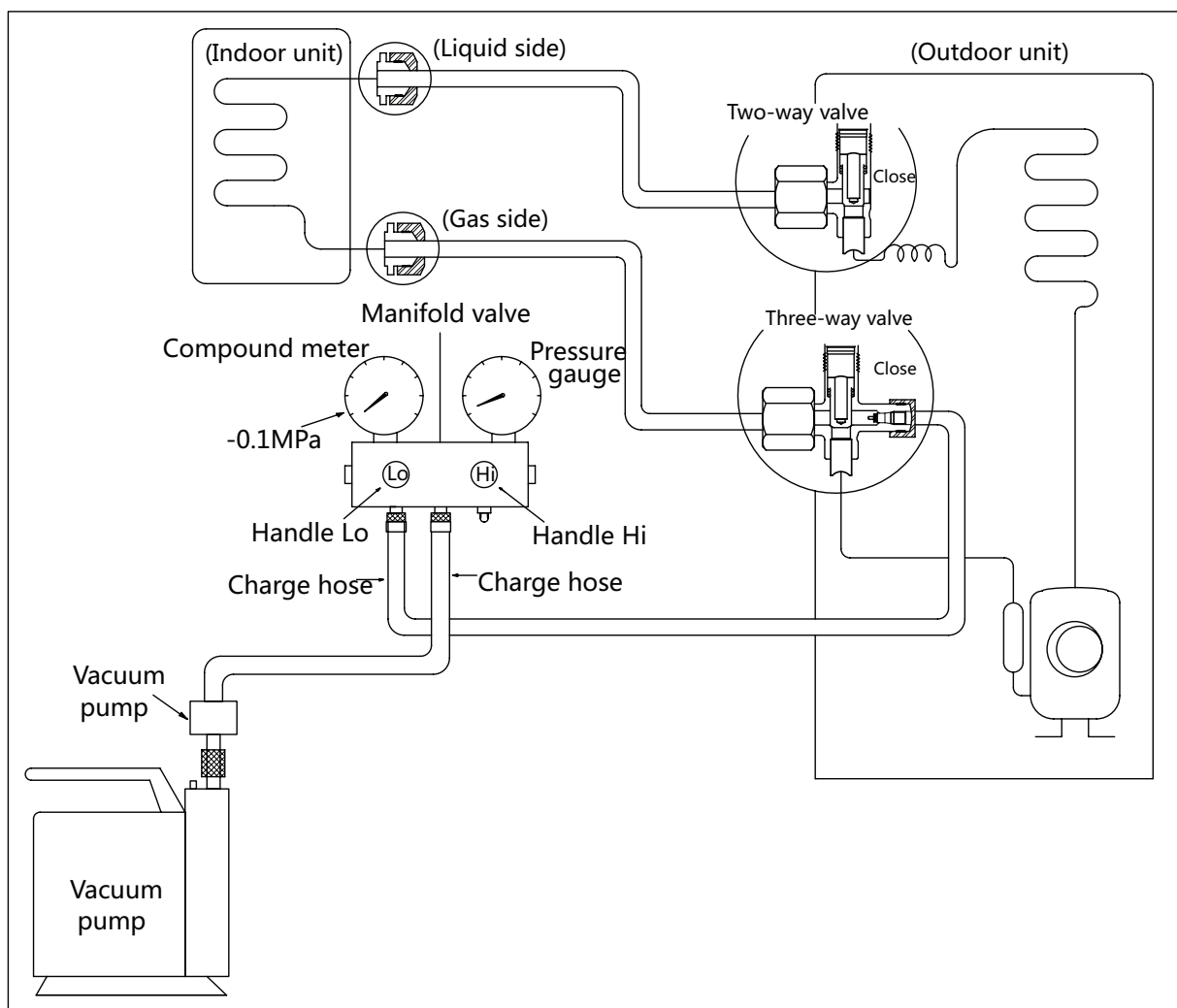

Procedure:

1. Tighten the flare nuts of the indoor and outdoor units, and confirm that both the 2- and 3-way valves are closed.
2. Connect the charge hose with the push pin of Handle Lo to the gas service port of the 3-way valve.
3. Connect another charge hose to the vacuum pump.
4. Fully open the Handle Lo manifold valve.
5. Using the vacuum pump, evacuate the system for 30 minutes.
 - c. Check whether the compound meter indicates -0.1 MPa (14.5 Psi).
 - If the meter does not indicate -0.1 MPa (14.5 Psi) after 30 minutes, continue evacuating for an additional 20 minutes.
 - If the pressure does not achieve -0.1 MPa (14.5 Psi) after 50 minutes, check for leakage.
 - If the pressure successfully reaches -0.1 MPa (14.5 Psi), fully close the Handle Lo valve, then cease vacuum pump operations.
 - d. Wait for 5 minutes then check whether the gauge needle moves after turning off the vacuum pump. If the gauge needle moves backwards, check whether there is gas leakage.
6. Loosen the flare nut of the 3-way valve for 6 or 7 seconds and then tighten the flare nut again.
 - a. Confirm the pressure display in the pressure indicator is slightly higher than the atmospheric pressure.
 - b. Remove the charge hose from the 3-way valve.
7. Fully open the 2- and 3-way valves and tighten the cap of the 2- and 3-way valve.

1.3.2 Outdoor Unit

Evacuation for the whole system

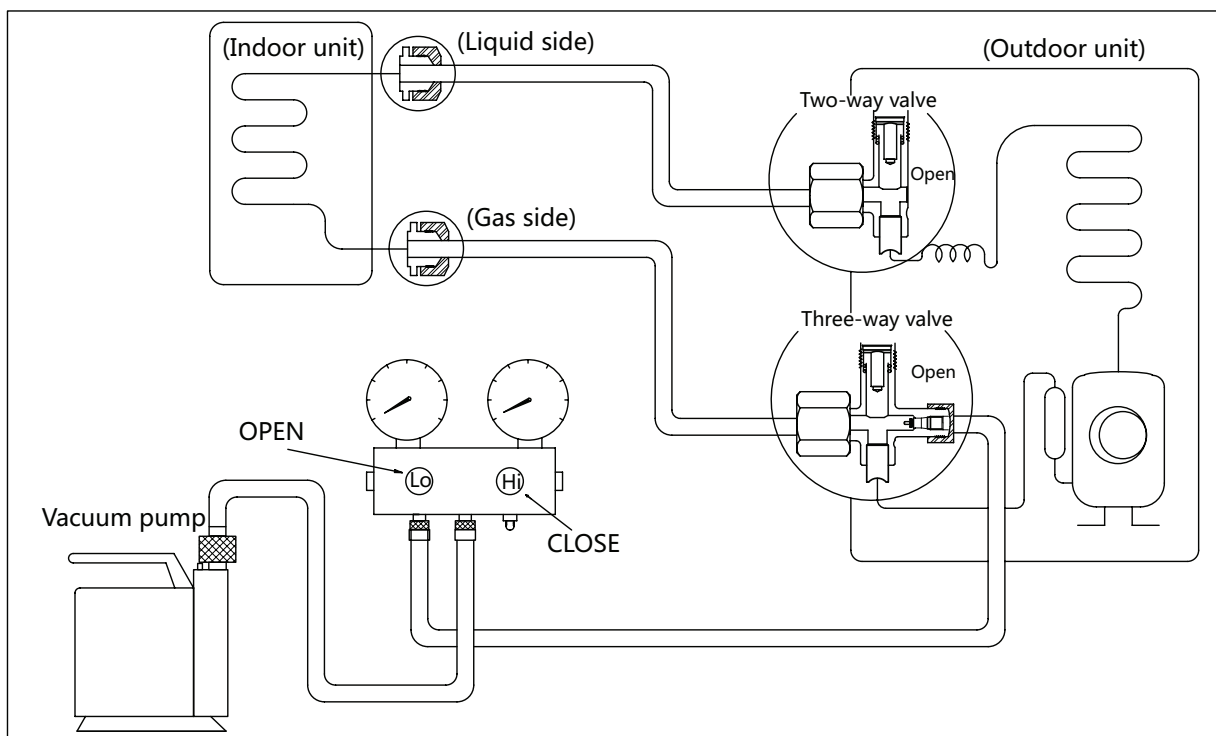

Procedure:

1. Confirm that the 2- and 3-way valves are opened.
2. Connect the vacuum pump to the 3-way valve's service port.
3. Evacuate the system for approximately one hour. Confirm that the compound meter indicates -0.1 MPa (14.5Psi).
4. Close the valve (Low side) on the charge set and turn off the vacuum pump.
5. Wait for five minutes then check whether the gauge needle moves after turning off the vacuum pump. If the gauge needle moves backward, check whether there is gas leakage.
6. Disconnect the charge hose from the vacuum pump.
7. Mount the caps of service port and 2- and 3-way valves.
7. Use a torque wrench to tighten the caps to a torque of 18N.m.

Refrigerant charging

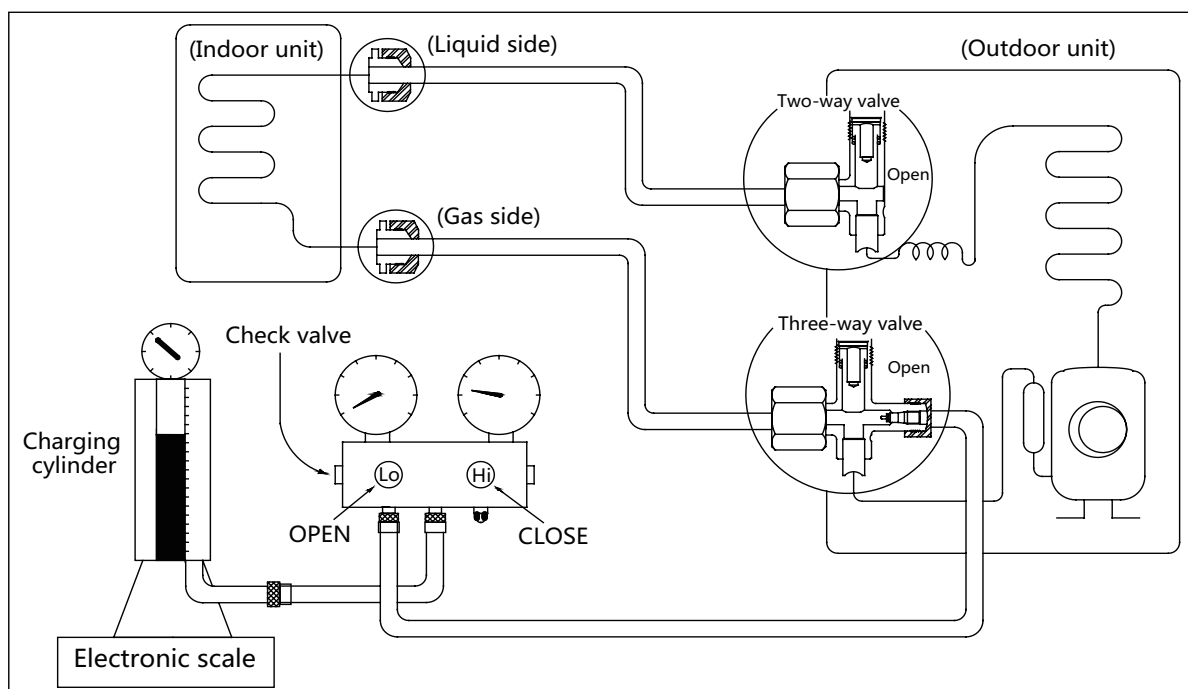

Procedure:

1. Tighten the flare nuts of the indoor and outdoor units, and confirm that both the 2- and 3-way valves are closed.
2. Slightly connect the Handle Lo charge hose to the 3-way service port.
3. Connect the charge hose to the valve at the bottom of the cylinder.
If the refrigerant is R410A, invert the cylinder to ensure a complete liquid charge.
4. Partially open the Handle Lo manifold valve.
5. Open the valve at the bottom of the cylinder for 5 seconds to purge the air in the charge hose, then fully tighten the charge hose with the push pin of Handle Lo to the gas service port of the 3-way valve.
6. Place the charging cylinder onto an electronic scale and record the starting weight.
7. Fully open the Handle Lo manifold valve, 2- and 3-way valves.
8. Operate the air conditioner in cooling mode and charge the system with liquid refrigerant.
9. When the electronic scale displays the correct weight (refer to the gauge and the pressure of the low side to confirm), turn off the air conditioner, then disconnect the charge hose from the 3-way service port immediately.
10. Mount the caps of service port and 2- and 3-way valves.
11. Use a torque wrench to tighten the caps to a torque of 18N.m.
12. Check for gas leakage.

Note: 1. Mechanical connectors used indoors shall comply with local regulations.

2. When mechanical connectors are reused indoors, sealing parts shall be renewed. When flared joints are reused indoors, the flare part shall be re-fabricated.

2. Disassembly

2.1 Indoor unit

1. Front Panel

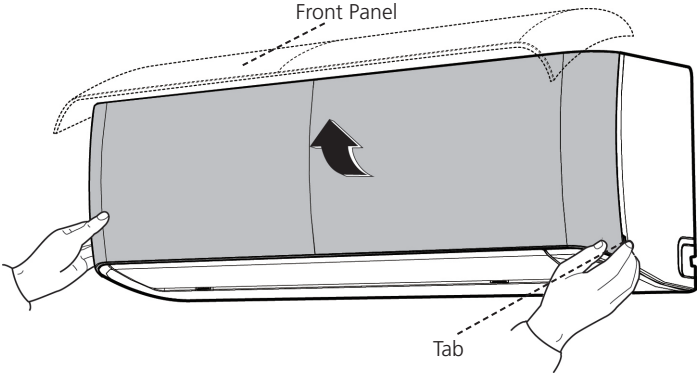
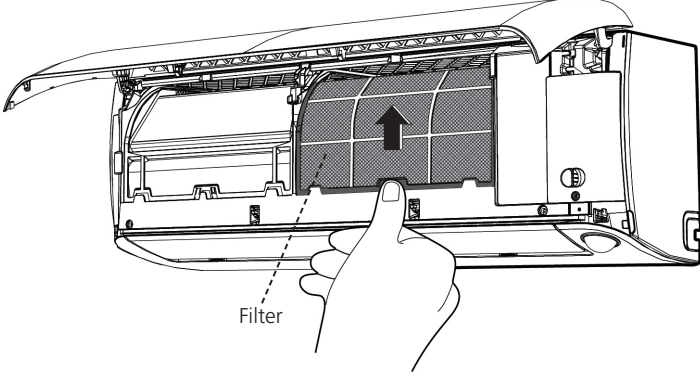
Procedure	Illustration
<p>3) Hold the front panel by the tabs on the both sides and lift it (see CJ_OP_INV_001).</p>	 <p style="text-align: center;">CJ_OP_INV_001</p>
<p>4) Push up the bottom of an air filter while pressing the bottom of the middle parts, and then pull the air filter out downwards (see CJ_OP_INV_002).</p>	 <p style="text-align: center;">CJ_OP_INV_002</p>

Note: This section is for reference only. Actual unit appearance may vary.

Procedure	Illustration
<p>5) Open the horizontal louver and push the hook towards right to open it (see CJ_OP_INV_003).</p>	<p style="text-align: center;">CJ_OP_INV_003</p>
<p>6) Bend the horizontal louver lightly by both hands to loosen the hooks, then remove the horizontal louver (see CJ_OP_INV_004).</p>	<p style="text-align: center;">CJ_OP_INV_004</p>

Note: This section is for reference only. Actual unit appearance may vary.

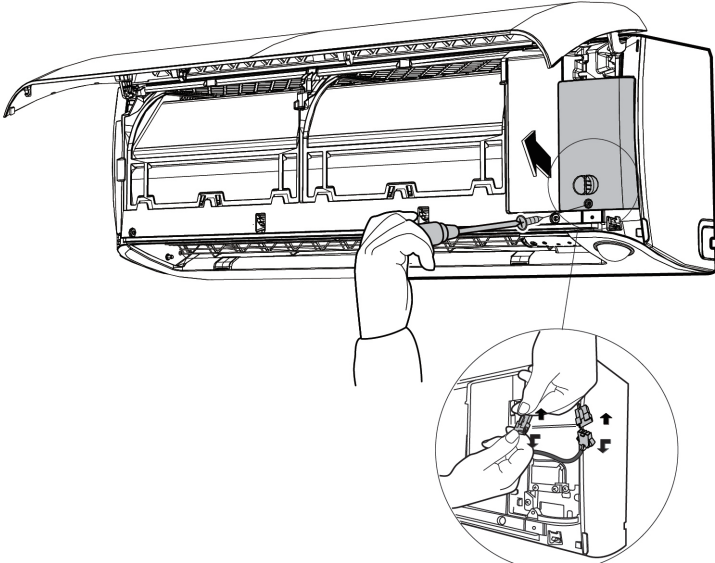
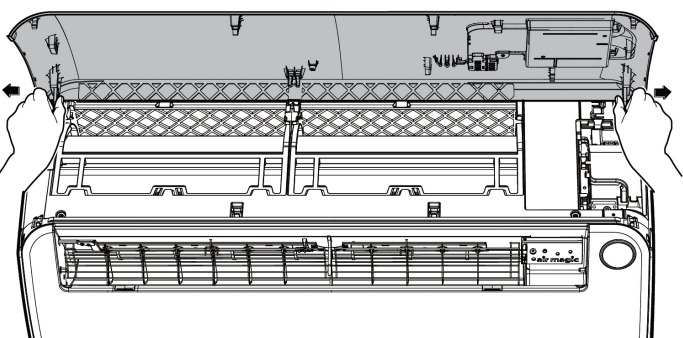
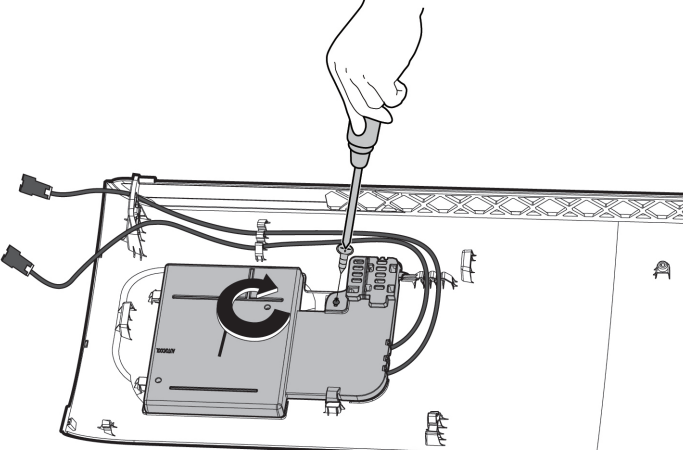
Procedure	Illustration
<p>7) Remove 1 screw and then remove the electrical cover(see CJ_OP_INV_005).</p> <p>8) Disconnect the two connectors for display board(see CJ_OP_INV_005) .</p>	 <p style="text-align: center;">CJ_OP_INV_005</p>
<p>9) Slid the front panel side to side to release each axis (see CJ_OP_INV_006)</p>	 <p style="text-align: center;">CJ_OP_INV_006</p>
<p>10) Remove one screw and rotate the display board clockwise. Then take it out of the clips. (see CJ_OP_INV_007).</p>	 <p style="text-align: center;">CJ_OP_INV_007</p>

Note: This section is for reference only. Actual unit appearance may vary.

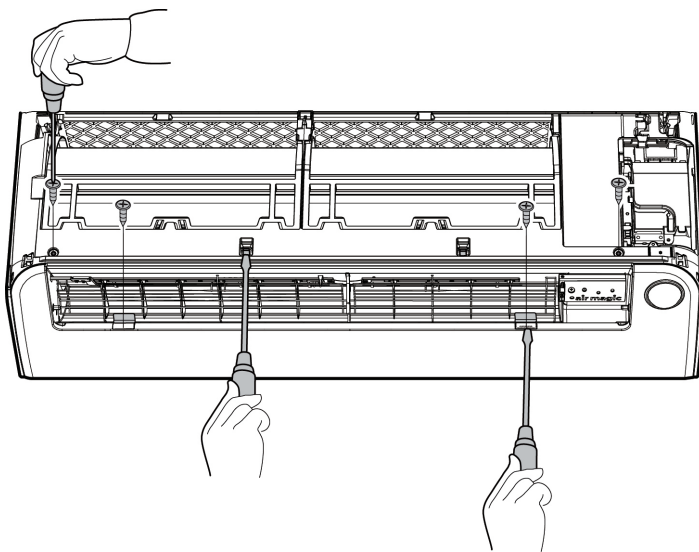
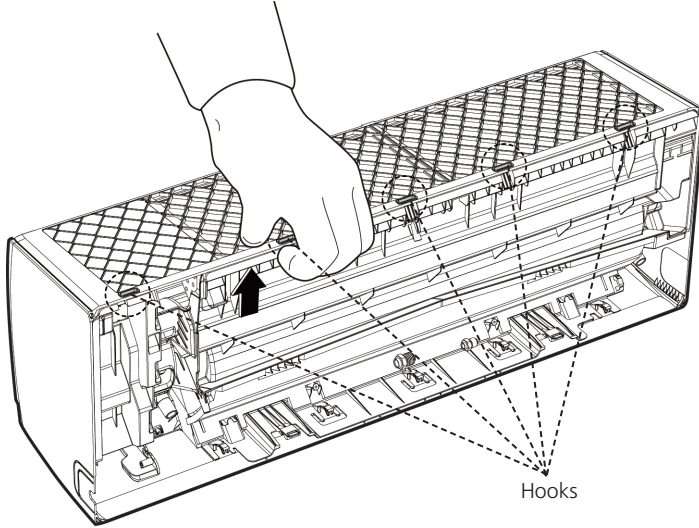
Procedure	Illustration
<p>11) Open the screw caps(2) and then remove the 4 screws (see CJ_OP_INV_008).</p> <p>12) Release the 2 hooks.</p>	 <p style="text-align: center;">CJ_OP_INV_008</p>
<p>13) Release the 5 hooks in the back (see CJ_OP_INV_009).</p> <p>14) Pull out the panel frame from the indoor unit.</p>	 <p style="text-align: center;">CJ_OP_INV_009</p>

Note: This section is for reference only. Actual unit appearance may vary.

2. Electrical parts

Note: Remove the front panel (refer to 1. Front panel) before disassembling electrical parts.

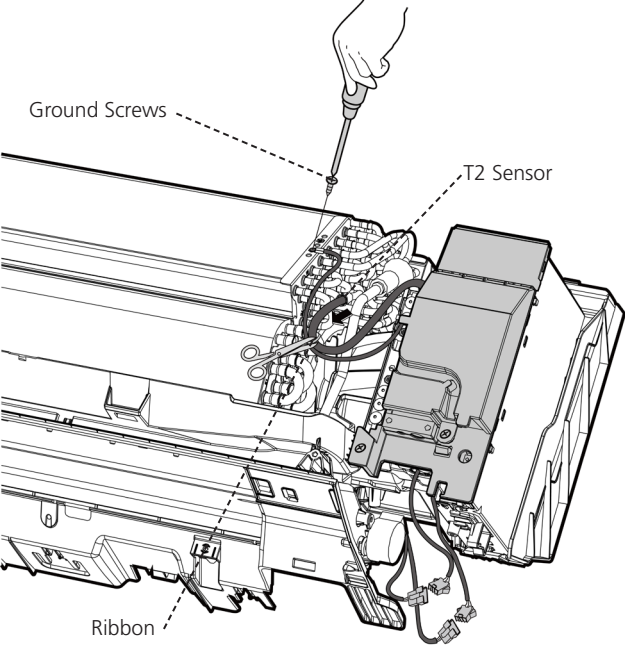
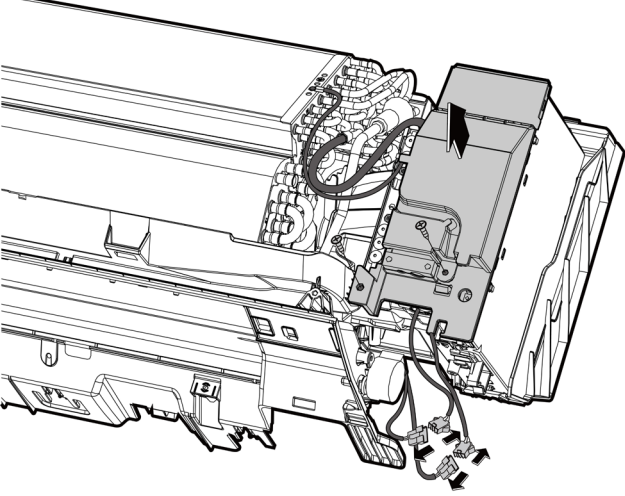
Procedure	Illustration
<p>1) Cut the ribbon by a shear, then pull out the coil temperature sensor (T2) (see CJ_OP_INV_010).</p> <p>2) Remove the two screws used for the ground connection (see CJ_OP_INV_010).</p>	 <p>CJ_OP_INV_010</p>
<p>3) Remove the fixing screws(1 for electronic cover and 1 for terminal cover), and then remove the cover of electronic box and the terminal cover along the direction indicated in right image to remove it.</p> <p>4) Disconnect the connector of fan motor and the step motor (see CJ_OP_INV_011).</p>	 <p>CJ_OP_INV_011</p>

Note: This section is for reference only. Actual unit appearance may vary.

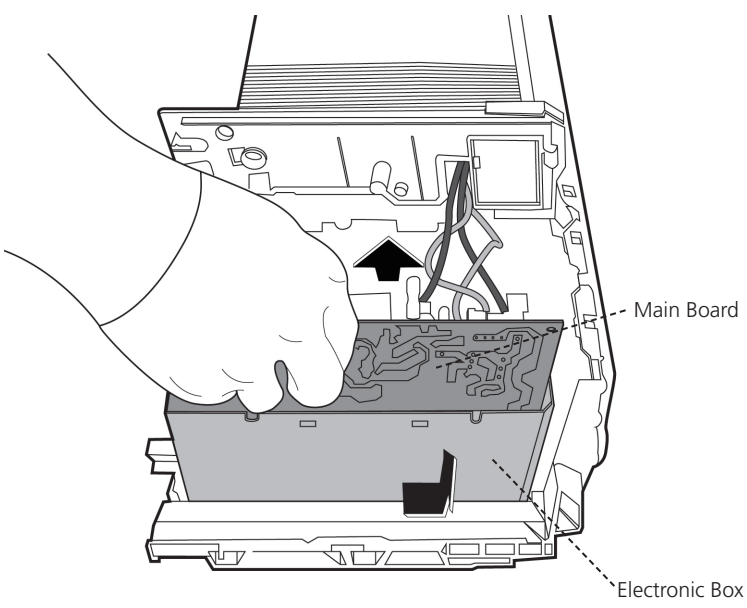
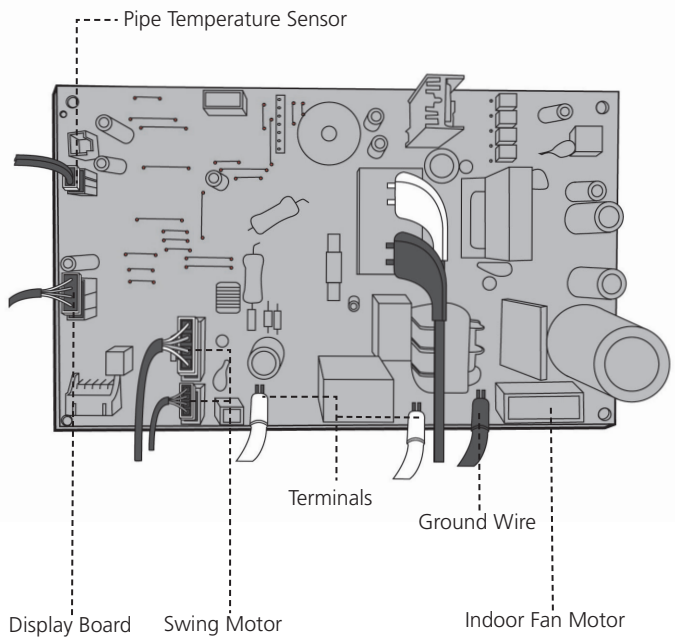
Procedure	Illustration
<p>5) Disconnect the wires. Then remove the electronic main box (CJ_OP_INV_011-2).</p> <p>6) Pull out the Electrical control box along the direction indicated in right image. to remove it (CJ_OP_INV_011-2).</p>	 <p style="text-align: center;">CJ_OP_INV_012</p>
<p>7) The connector of each port is indicated in right image. (CJ_OP_INV_013).</p>	 <p style="text-align: center;">CJ_OP_INV_013</p>

Note: This section is for reference only. Actual unit appearance may vary.

3. Evaporator

Note: Remove the front panel and electrical parts (refer to 1. Front panel and 2. Electrical parts) before disassembling evaporator.

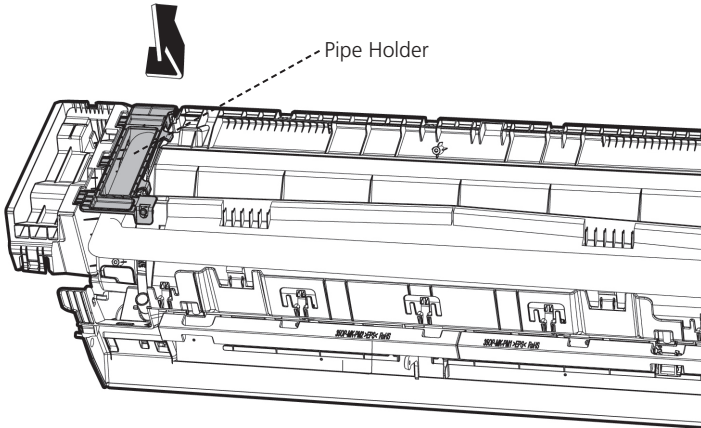
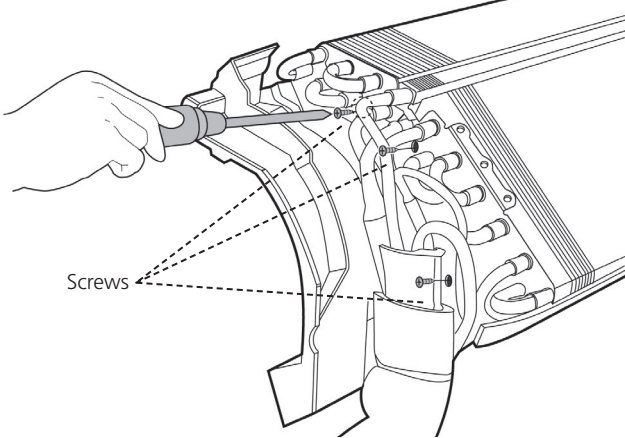
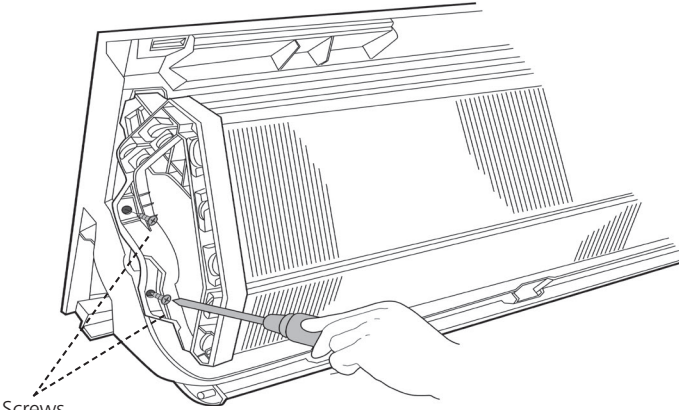
Procedure	Illustration
1) Disassemble the pipe holder located at the rear of the unit (see CJ_OP_INV_014).	 <p style="text-align: center;">CJ_OP_INV_014</p>
2) Remove the 3 screws on the evaporator located at the fixed plate (see CJ_OP_INV_015).	 <p style="text-align: center;">CJ_OP_INV_015</p>
3) Remove the 2 screws on the evaporator located at the base of the bearing side (see CJ_OP_INV_016).	 <p style="text-align: center;">CJ_OP_INV_016</p>

Note: This section is for reference only. Actual unit appearance may vary.

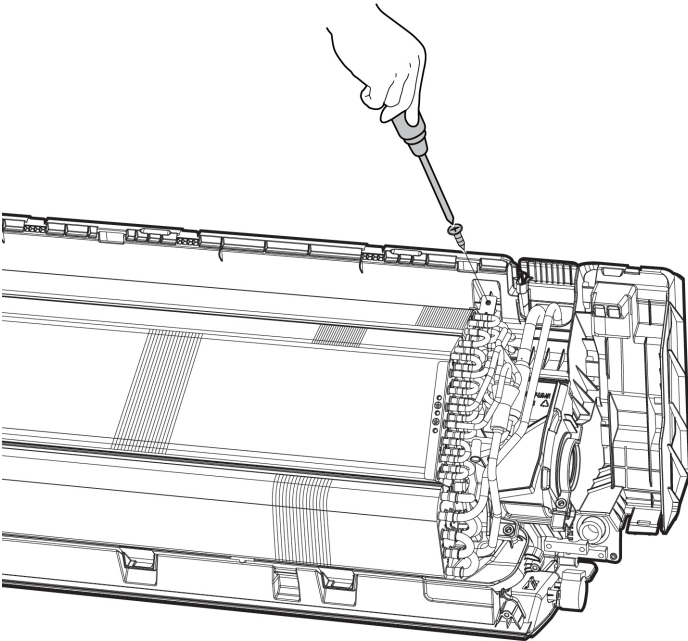
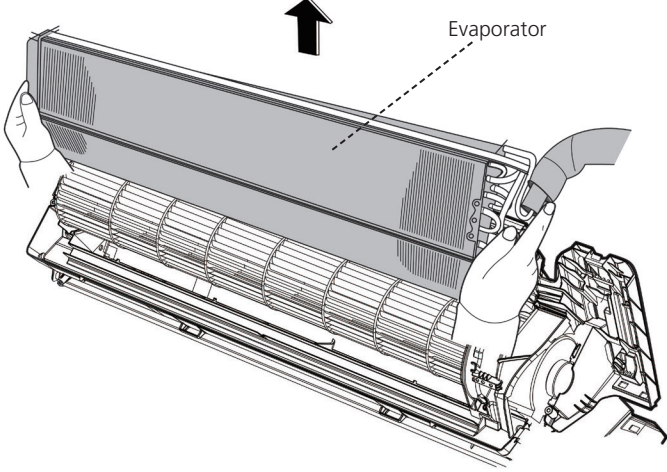
Procedure	Illustration
<p>4) Remove 1 screw on the evaporator located at the top of the evaporator. (see CJ_OP_INV_017).</p>	 <p style="text-align: center;">CJ_OP_INV_017</p>
<p>5) Pull out the evaporator (see CJ_OP_INV_017).</p>	 <p style="text-align: center;">CJ_OP_INV_017</p>

Note: This section is for reference only. Actual unit appearance may vary.

4. Fan motor and fan

Note: Remove the front panel, electrical parts and evaporator (refer to 1. Front panel, 2. Electrical parts, and 3. Evaporator). before disassembling fan motor and fan.

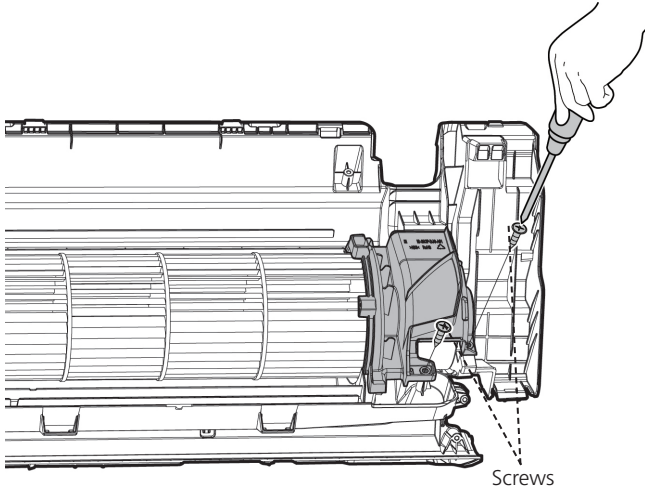
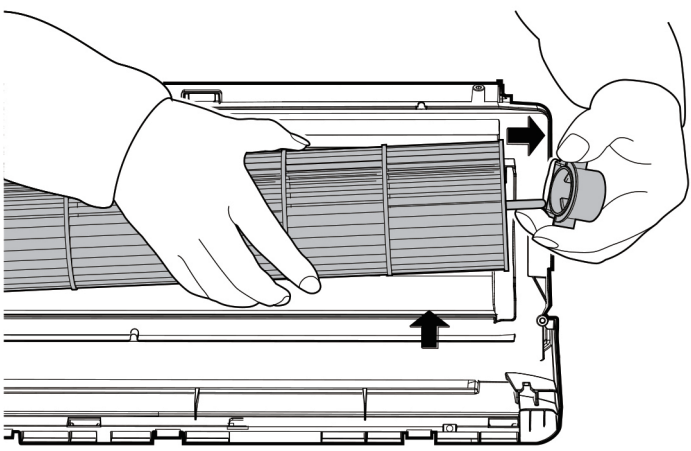
Procedure	Illustration
1) Remove the two screws and remove the fixing board of the fan motor (see CJ_OP_INV_018).	 <p data-bbox="938 1041 1141 1075">CJ_OP_INV_018</p>
2) Remove the bearing sleeve (see CJ_OP_INV_019).	 <p data-bbox="938 1747 1141 1780">CJ_OP_INV_019</p>

Note: This section is for reference only. Actual unit appearance may vary.

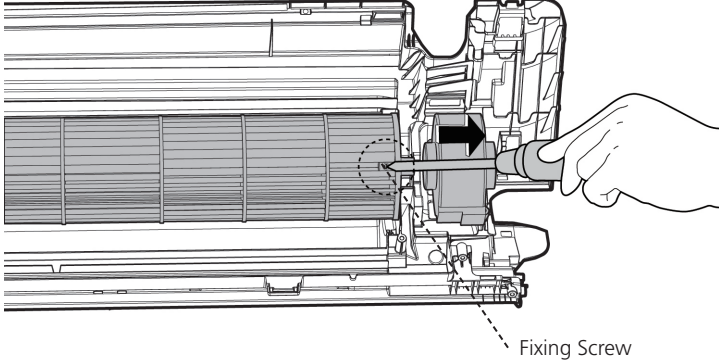
Procedure	Illustration
<p>3) Remove the fixing screw (see CJ_OP_INV_020).</p> <p>4) Pull out the fan motor and fan assembly from the side.</p>	 <p>CJ_OP_INV_021</p>

Note: This section is for reference only. Actual unit appearance may vary.

5. Step motor

Note: Remove the front panel and electrical parts (refer to 1. Front panel, 2. Electrical parts) before disassembling step motor.

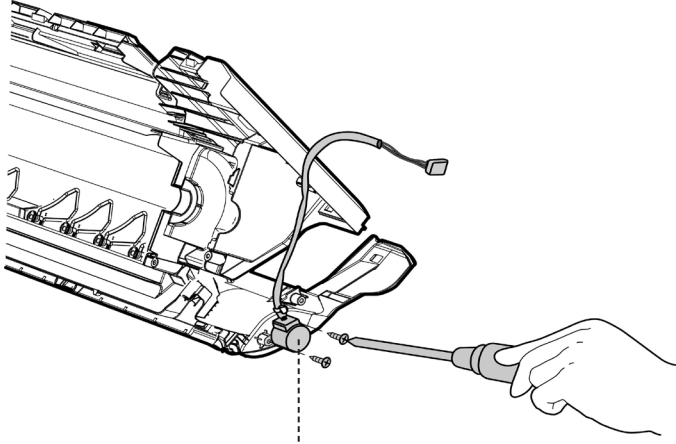
Procedure	Illustration
1) Remove the two screws, then remove the stepping motor (see CJ_OP_INV_021).	 <p data-bbox="932 909 1075 936">Stepping Motor</p> <p data-bbox="938 1005 1139 1032">CJ_OP_INV_021</p>

6. INTELLIGENT EYE

Note: Remove the front panel and electrical parts (refer to 1. Front panel, 2. Electrical parts, 3. Evaporator and 4. Fan motor and fan) before disassembling step motor.

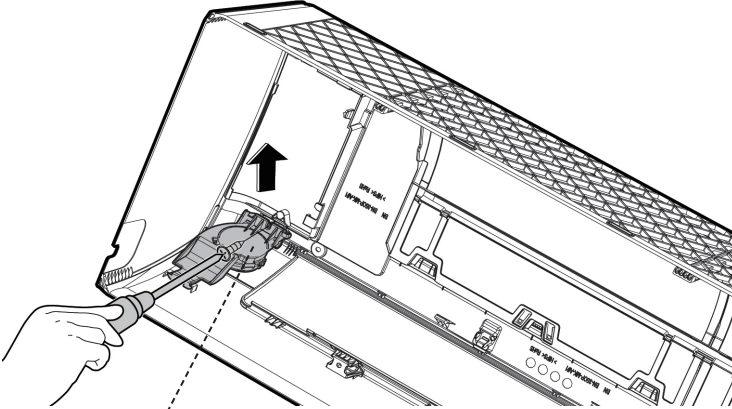
Procedure	Illustration
1) Remove the 1 screw, then remove the intelligent eye. (see CJ_OP_INV_021).	 <p data-bbox="735 1839 863 1865">Intelligent Eye</p> <p data-bbox="938 1839 1139 1865">CJ_OP_INV_021</p>

Note: This section is for reference only. Actual unit appearance may vary.

2.2 Outdoor unit

1. Panel Plate

MOCA30-09HFN1-MZA5W, MOCA30-12HFN1-MZ50W

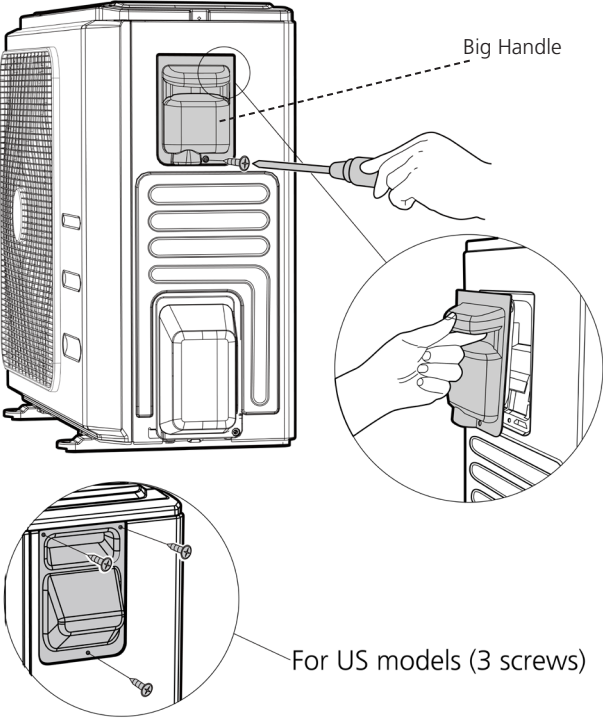
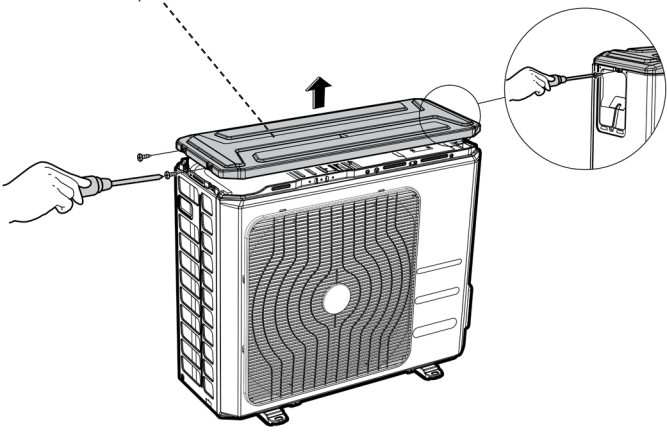
Procedure	Illustration
<p>1) Turn off the air conditioner and the power breaker.</p> <p>2) Remove the screws of the big handle and then remove the big handle (3 screws) (see CJ_CA30_INV_001).</p>	 <p>Big Handle</p> <p>For US models (3 screws)</p> <p>CJ_CA30_INV_001</p>
<p>3) Remove the screws of the top cover and then remove the top cover (3 screws). One of the screws is located underneath the big handle (see CJ_CA30_INV_002).</p>	 <p>Top Cover</p> <p>CJ_CA30_INV_002</p>

Note: This section is for reference only. Actual unit appearance may vary.

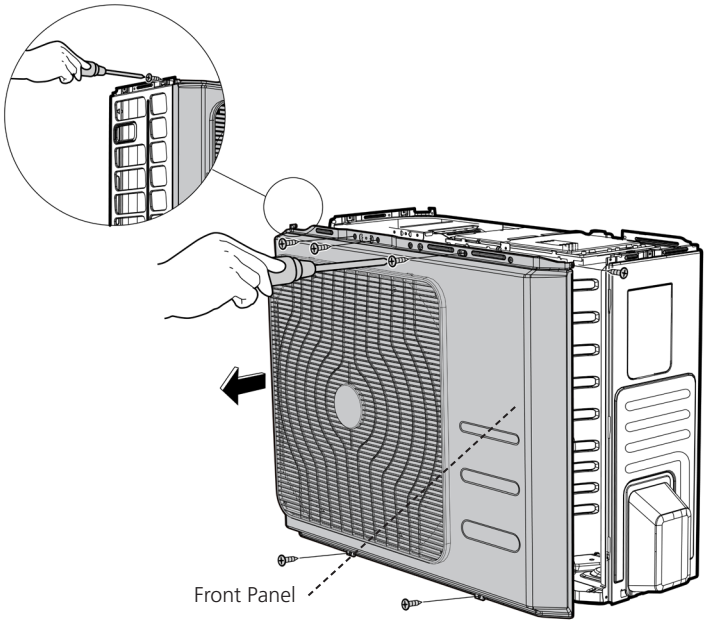
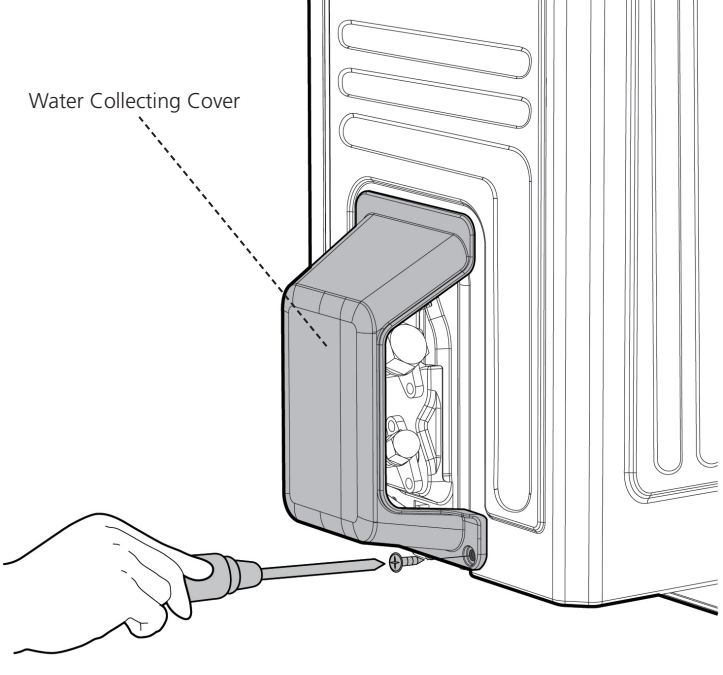
Procedure	Illustration
<p>4) Remove the screws of the front panel and then remove the front panel (7 screws) (see CJ_CA30_INV_003).</p>	 <p>Front Panel</p> <p>CJ_CA30_INV_003</p>
<p>5) Remove the screws of water collecting cover and then remove the water collecting cover (1 screw) (see CJ_CA30_INV_004).</p>	 <p>Water Collecting Cover</p> <p>CJ_CA30_INV_004</p>

Note: This section is for reference only. Actual unit appearance may vary.

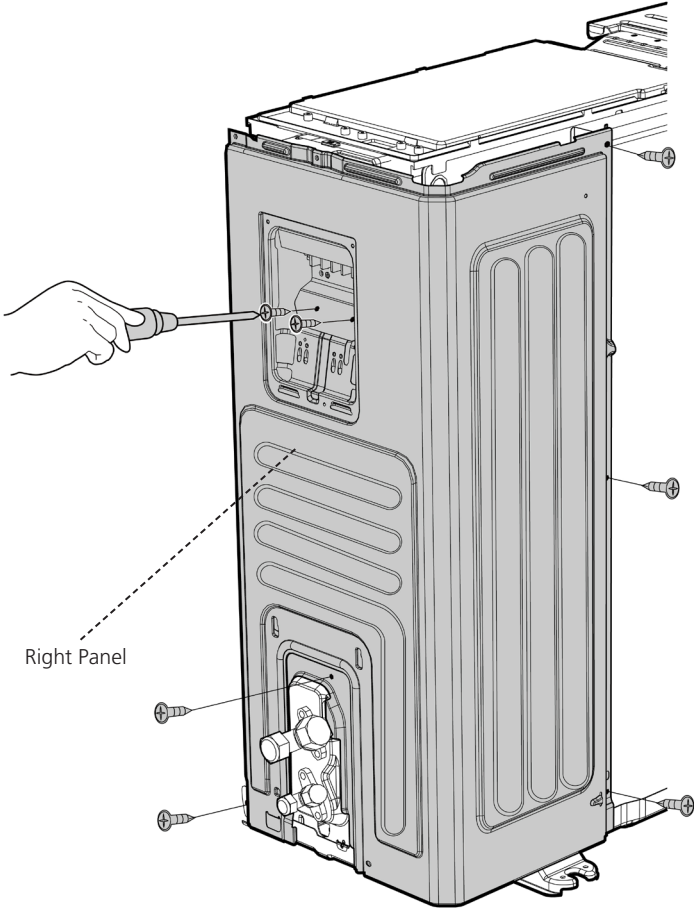
Procedure	Illustration
<p>6) Remove the screws of the right panel and then remove the right panel (6 screws) (see CJ_CA30_INV_005).</p>	 <p>The illustration shows a hand using a screwdriver to remove screws from the right panel of a unit. The unit is shown in a three-quarter view, with the right panel being the focus. A dashed line points to the right panel, which is labeled "Right Panel". The unit has a control panel on the left side and a door on the right side. The right panel is being removed from the back of the unit. The screws are being removed from the top, middle, and bottom of the panel. The unit is labeled "CJ_CA30_INV_005" at the bottom.</p>

Note: This section is for reference only. Actual unit appearance may vary.

2. Fan disassembly

Note: Remove the panel plate and (refer to 1. Panel plate) before disassembling fan.

MOCA30-09HFN1-MZA5W, MOCA30-12HFN1-MZ50W

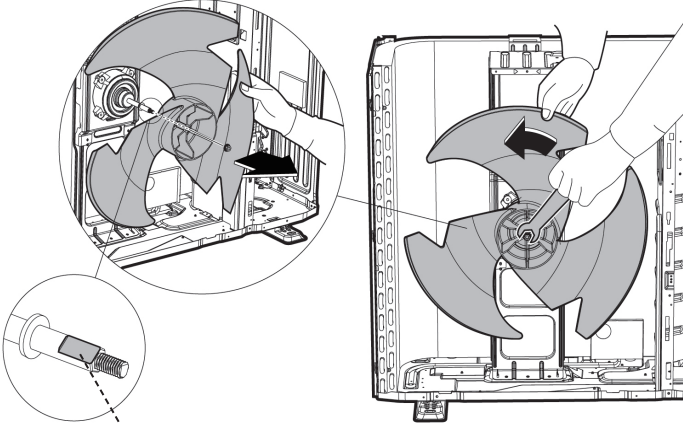
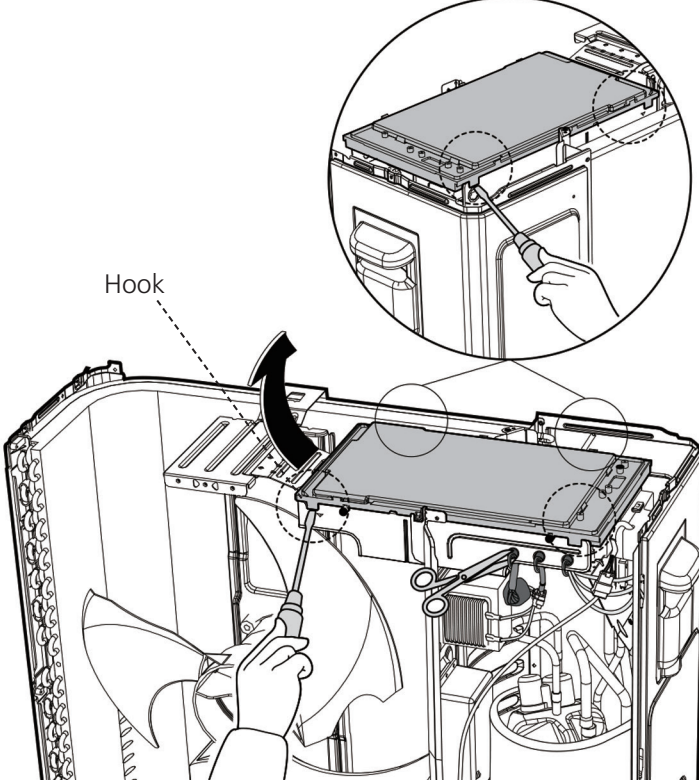
Procedure	Illustration
<p>1) Remove the nut securing the fan with a spanner (see CJ_ODU_INV_001).</p> <p>2) Remove the fan.</p>	 <p style="text-align: center;">CJ_ODU_INV_001</p>
<p>3) Unfix the hooks and then open the electronic control box cover (4 hooks) (see CJ_ODU_INV_002).</p>	 <p style="text-align: center;">CJ_ODU_INV_002</p>

Note: This section is for reference only. Actual unit appearance may vary.

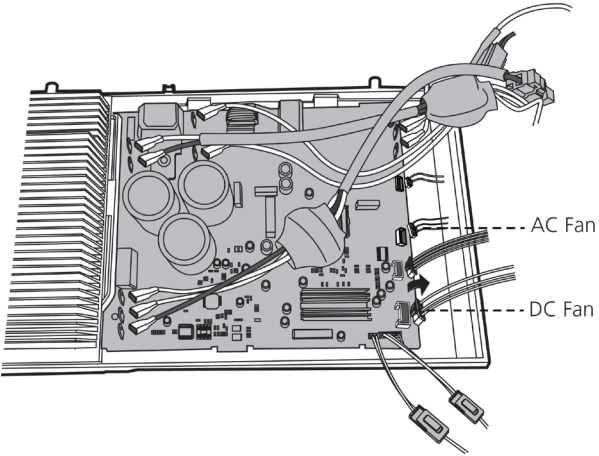
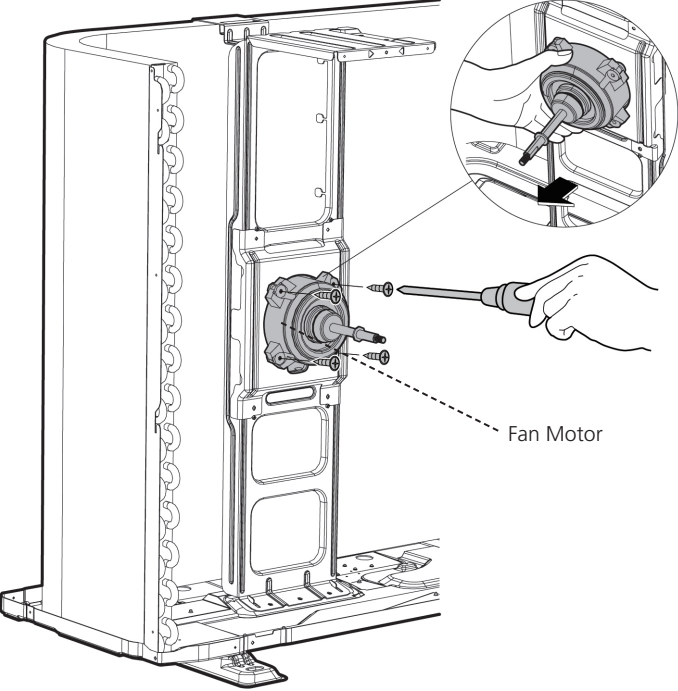
Procedure	Illustration
<p>4) Disconnect the connector for fan motor from the electronic control board (see CJ_ODU_INV_003).</p>	 <p style="text-align: right;">AC Fan DC Fan</p> <p style="text-align: center;">CJ_ODU_INV_003</p>
<p>5) Remove the fixing screws of the fan motor (4 screws) (see CJ_ODU_INV_004).</p> <p>6) Remove the fan motor.</p>	 <p style="text-align: right;">Fan Motor</p> <p style="text-align: center;">CJ_ODU_INV_004</p>

Note: This section is for reference only. Actual unit appearance may vary.

3. Electrical parts

Note: Remove the panel plate and fan assembly (refer to 1. Panel plate and 2. Fan assembly) before disassembling electrical parts.

MOCA30-09HFN1-MZA5W, MOCA30-12HFN1-MZ50W

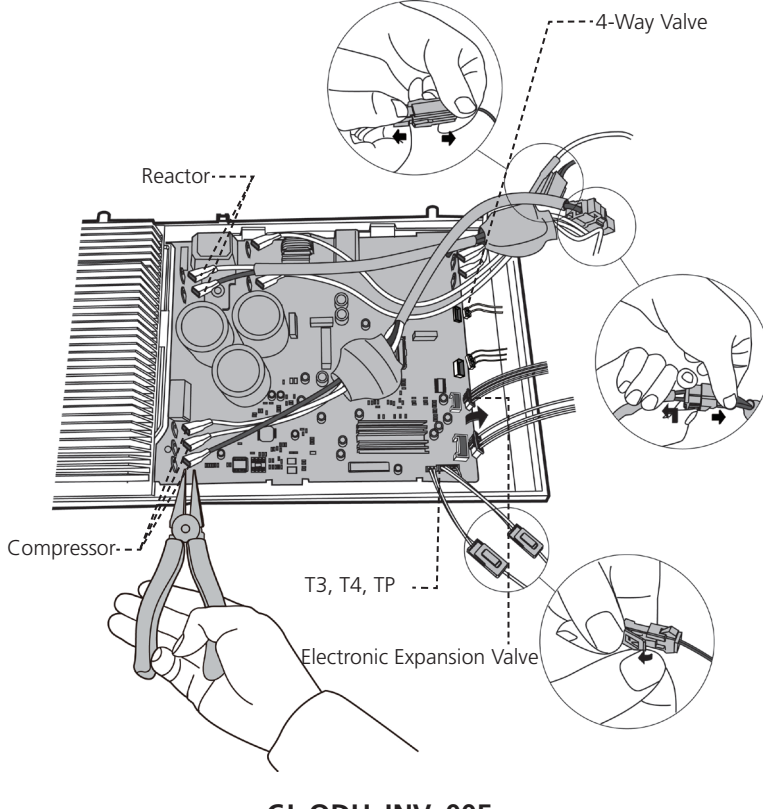
Procedure	Illustration
<ol style="list-style-type: none">1) Remove the connector for the compressor (see CJ_ODU_INV_005).2) Pull out the two blue wires connected with the four way valve (see CJ_ODU_INV_005).3) Pull out connectors of the condenser coil temp. sensor(T3), outdoor ambient temp. sensor(T4) and discharge temp. sensor(T5) (see CJ_ODU_INV_005).4) Disconnect the electronic expansion valve wire (see Fig CJ_ODU_INV_005).5) Remove the connector for electric heaters (see Fig CJ_ODU_INV_005).6) Remove the connector for the reactor (see Fig CJ_ODU_INV_005).7) Then remove the electronic control box (see Fig CJ_ODU_INV_005).	 <p>The illustration shows the internal electrical components of the ODU. A hand is using pliers to disconnect a wire from the compressor. Callouts point to various components: Reactor, Compressor, 4-Way Valve, T3, T4, TP, and Electronic Expansion Valve. The diagram is labeled CJ_ODU_INV_005.</p>

Note: This section is for reference only. Actual unit appearance may vary.

4. Sound blanket

⚠ WARNING: Recover refrigerant from the refrigerant circuit before remove the compressor.

Note: Remove the panel plate, electrical parts, and fan assembly (refer to 1. Panel plate, 2. Electrical parts, and 3. Fan assembly) before disassembling sound blanket.

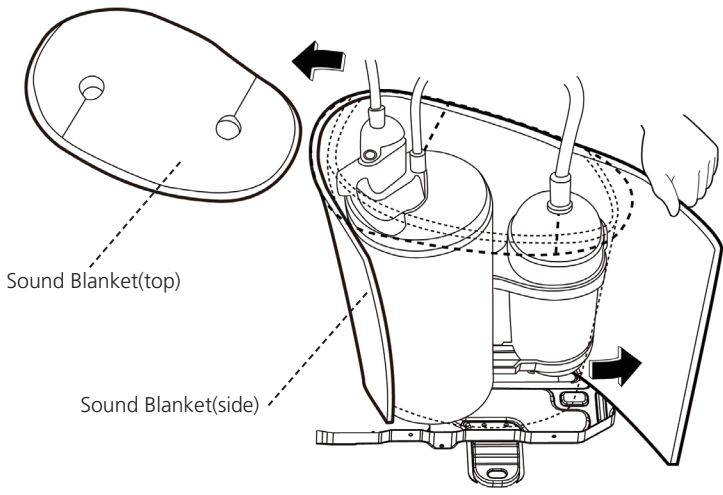
Procedure	Illustration
1) Remove the sound blanket (side and top) (see CJ_ODU_INV_006).	 <p data-bbox="901 1064 1133 1097">CJ_ODU_INV_006</p>

Note: This section is for reference only. Actual unit appearance may vary.

5. Four-way valve

⚠ WARNING: Recover refrigerant from the refrigerant circuit before remove the four-way valve.

Note: Remove the panel plate, electrical parts, and fan assembly (refer to 1. Panel plate, 2. Electrical parts, and 3. Fan assembly) before disassembling four-way valve.

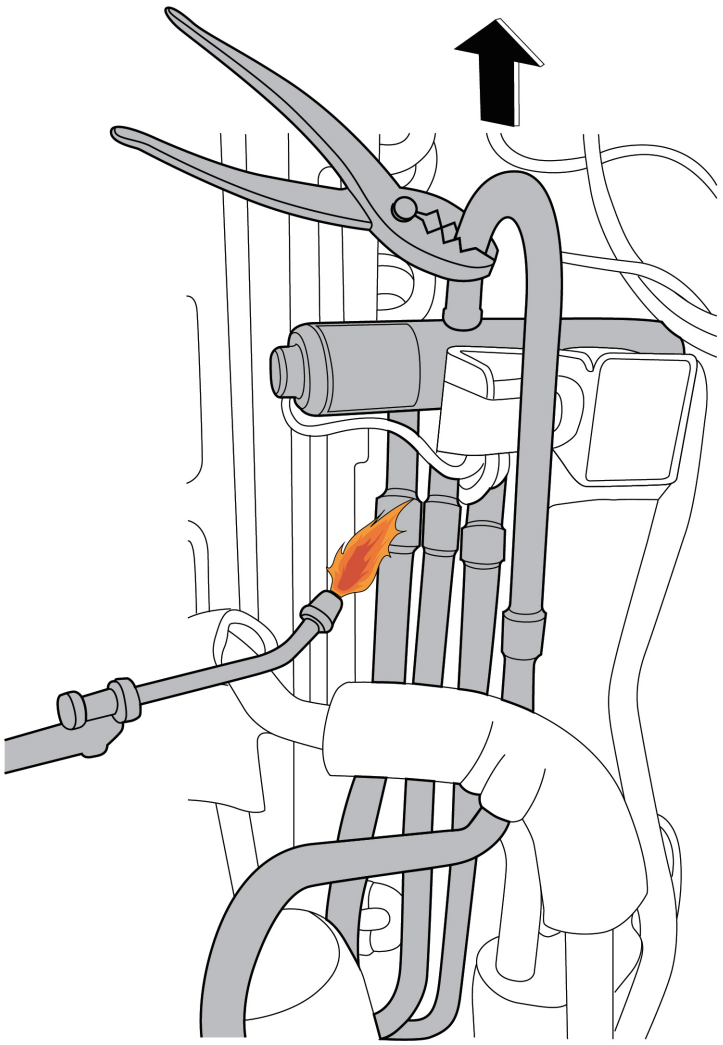
Procedure	Illustration
<ol style="list-style-type: none">1) Heat up the brazed parts and then detach the the four-way valve and the pipe (see CJ_ODU_INV_007).2) Remove the four-way valve assembly with pliers.	 <p>CJ_ODU_INV_007</p>

Note: This section is for reference only. Actual unit appearance may vary.

6. Compressor

⚠ WARNING: Recover refrigerant from the refrigerant circuit before remove the compressor.

Note: Remove the panel plate, electrical parts, and fan assembly (refer to 1. Panel plate, 2. Electrical parts, and 3. Fan assembly) before disassembling compressor.

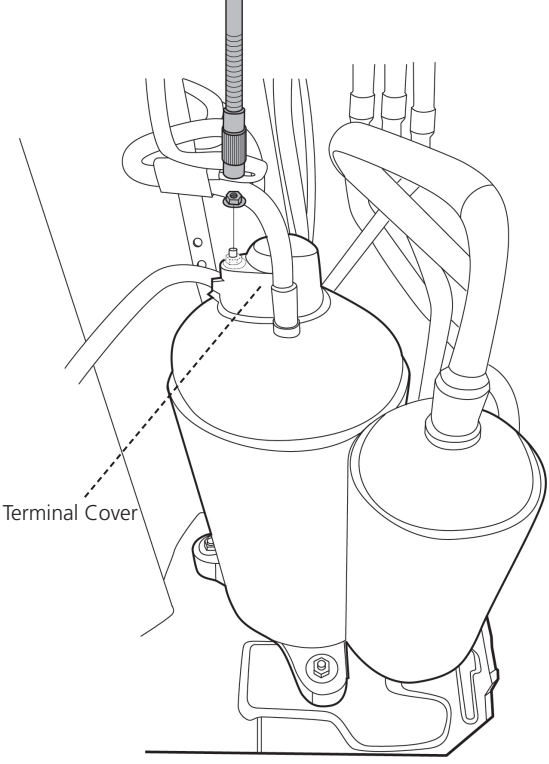
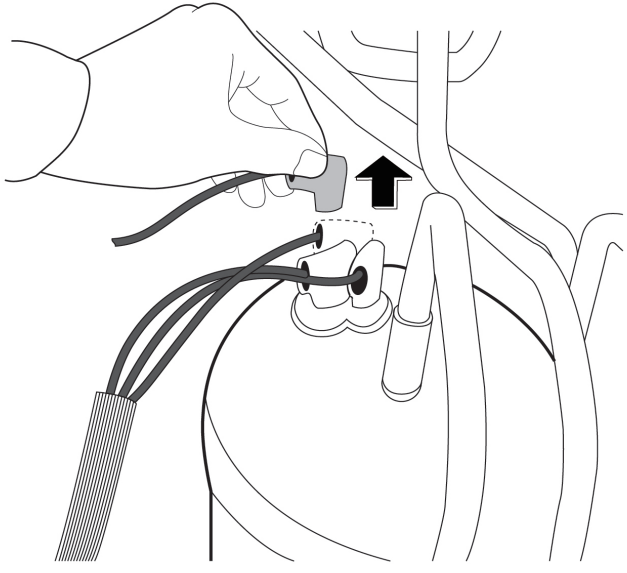
Procedure	Illustration
<p>1) Remove the flange nut of terminal cover and remove the terminal cover (see CJ_ODU_INV_008).</p>	 <p>The diagram shows a top-down view of the compressor assembly. A dashed line points to a terminal cover on the left side of the unit. The cover is being lifted away from the terminal block.</p> <p style="text-align: center;">CJ_ODU_INV_008</p>
<p>2) Disconnect the connectors (see CJ_ODU_INV_009).</p>	 <p>The diagram shows a close-up of a hand using a tool to disconnect a connector from the terminal block. An upward-pointing arrow indicates the direction of the tool's movement.</p> <p style="text-align: center;">CJ_ODU_INV_009</p>

Note: This section is for reference only. Actual unit appearance may vary.

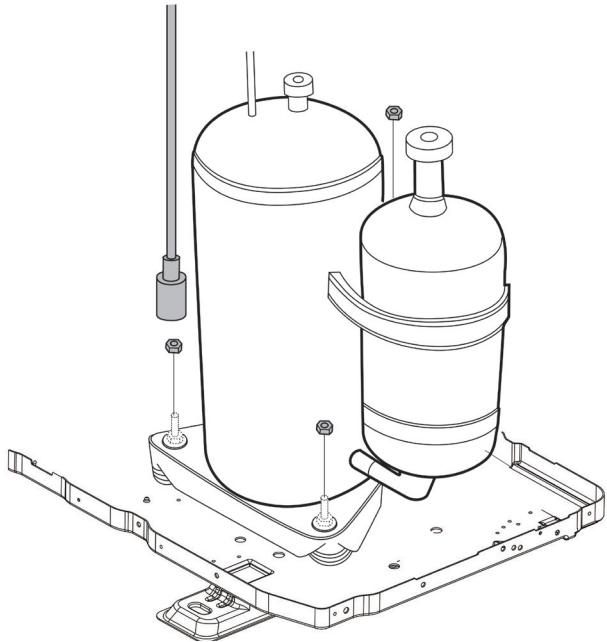
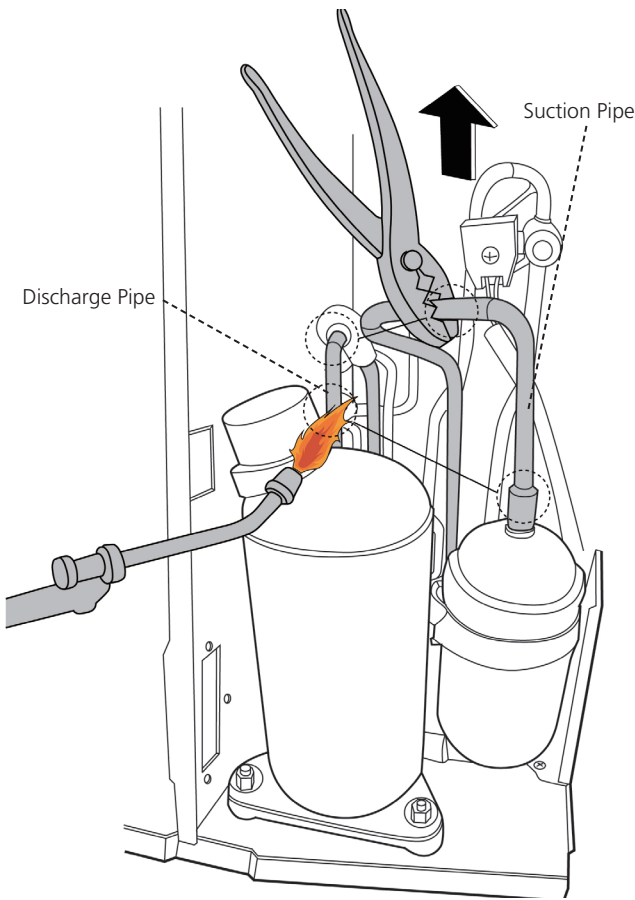
Procedure	Illustration
<p>3) Remove the hex nuts and washers securing the compressor, located on the bottom plate (see CJ_ODU_INV_010).</p>	 <p style="text-align: center;">CJ_ODU_INV_010</p>
<p>4) Heat up the brazed parts and then remove the the discharge pipe and the suction pipe (see CJ_ODU_INV_011).</p> <p>5) Lift the compressor from the base pan assembly with pliers.</p>	 <p style="text-align: center;">CJ_ODU_INV_011</p>

Note: This section is for reference only. Actual unit appearance may vary.

Troubleshooting

Contents

1.	Safety Caution	47
2.	General Troubleshooting	48
3.	Error Diagnosis and Troubleshooting Without Error Code.....	49
	3.1 Remote maintenance.....	49
	3.2 Field maintenance	50
4.	Quick Maintenance by Error Code.....	55
5.	Troubleshooting by Error Code.....	57
	5.1 Common Check Procedures.....	57
	5.2 E0/F4/EA (EEPROM parameter error)	59
	5.3 E1 (Indoor and outdoor unit communication error)	60
	5.4 E3/F5 (Fan speed is operating outside of the normal range)	62
	5.5 EF (Intelligent eye module error diagnosis and solution)	64
	5.6 E4/E5/F1/F2/F3 (Open circuit or short circuit of temperature sensor diagnosis and solution).....	65
	5.7 Eb (Communication error between the indoor PCB and display board).....	66
	5.8 F0(Overload current protection diagnosis and solution)	67
	5.9 P0(IPM malfunction diagnosis and solution)	68
	5.10 P1(Over voltage or too low voltage protection diagnosis and solution).....	69

Troubleshooting

Contents

5.11	P2(High temperature protection of IPM module diagnosis and solution).....	71
5.12	P4(Inverter compressor drive error diagnosis and solution)	72
5.13	Compressor driven chip EEPROM parameter error diagnosis and solution.....	73
5.14	Zero speed protection of compressor/ outdoor fan or lack of phase of compressor or outdoor fan/Compressor speed malfunction diagnosis and solution	74
5.15	Communication error between outdoor main chip and compressor driven chip diagnosis and solution	75
5.16	IGBT over-strong current protection diagnosis and solution).....	76

1. Safety Caution

WARNING

Electricity remains in capacitors even when the power supply is off.
Ensure the capacitors are fully discharged before troubleshooting.

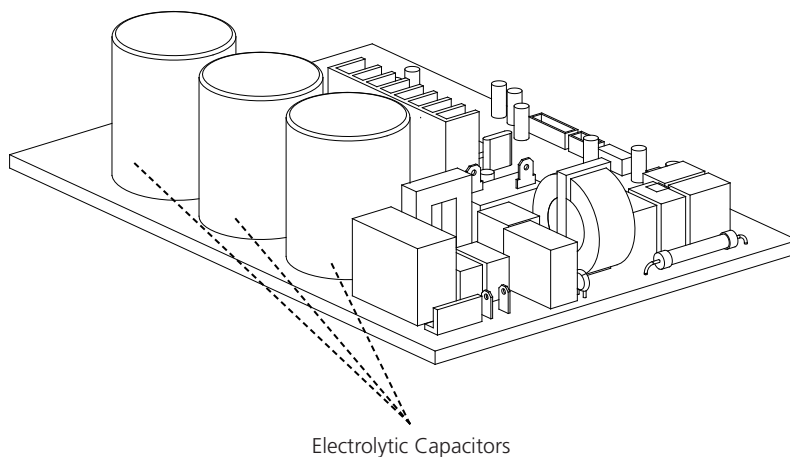

For other models, connect discharge resistance (approx. 100Ω 40W) or a soldering iron plug between the positive and negative terminals of the electrolytic capacitor. The terminals are located on the bottom surface of the outdoor PCB.

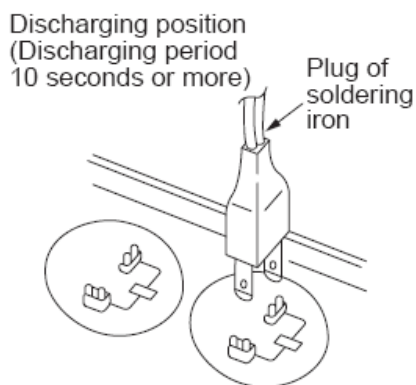

Note: This picture is for reference only. Actual appearances may vary.

2. General Troubleshooting

2.1 Error Display (Indoor Unit)

When the indoor unit encounters a recognized error, and an error code will be displayed. These error codes are described in the following table:

Display	Error Information	Solution
E0/EA	Indoor unit EEPROM parameter error	Page 58
E1	Indoor / outdoor units communication error	Page 59
E3	The indoor fan speed is operating outside of the normal range	Page 61
E4	Indoor room temperature sensor T1 is in open circuit or has short circuited	Page 64
E5	Evaporator coil temperature sensor T2 is in open circuit or has short circuited	Page 64
EB	Communication error between the indoor PCB and display board	Page 65
EF	Intelligent eye module error	Page 63
F0	Overload current protection	Page 66
F1	Outdoor ambient temperature sensor T4 open circuit or short circuit	Page 64
F2	Condenser coil temperature sensor T3 is in open circuit or has short circuited	Page 64
F3	Compressor discharge temperature sensor TP open circuit or short circuit	Page 64
F4	Outdoor unit EEPROM parameter error	Page 58
F5	The outdoor fan speed is operating outside of the normal range	Page 61
P0	IPM malfunction protection	Page 67
P1	Over voltage or over low voltage protection	Page 68
P2	High temperature protection of IPM module	Page 70
P4	Inverter compressor drive error	Page 71
P10	Over low voltage protection	Page 68
P11	Over voltage protection	Page 68

For other errors:

The display board may show a garbled code or a code undefined by the service manual. Ensure that this code is not a temperature reading.

Troubleshooting:

Test the unit using the remote control. If the unit does not respond to the remote, the indoor PCB requires replacement. If the unit responds, the display board requires replacement.

2.2 Error Display (outdoor Unit)

There are three LED on outdoor PCB: LED1(Yellow color), LED2(Red color) and LED3(Green color)

When the unit is standby, LED1 flashes at 0.5Hz. When the unit has some problems, it flashes at 2.5Hz. When operate normally, it is on. When in low ambient cooling mode, it flashes 4 times then stops 4 seconds.

LED2(Red color) and LED3(Green color) refer to the following table:

LED2 (Red)	LED3 (Green)	Error Information	Solution
ON	OFF	Normal operation	Normal
OFF	ON	Normal standby	Normal
FLASH	OFF	Compressor speed malfunction or outdoor fan speed malfunction	Page 61/74
FLASH	ON	Compressor driven chip EEPROM parameter error	Page 73
ON	FLASH	Zero speed protection of compressor/ outdoor fan or lack of phase of compressor or outdoor fan	Page 74
ON	ON	DC voltage too high/too low protection	Page 71
FLASH	FLASH	IGBT strong current protection	Page 76
OFF	FLASH	IPM module protection	Page 67
FLASH	FLASH	Communication error between outdoor main chip and compressor driven chip	Page 75

3. Error Diagnosis and Troubleshooting Without Error Code

WARNING

Be sure to turn off unit before any maintenance to prevent damage or injury.

3.1 Remote maintenance

SUGGESTION: When troubles occur, please check the following points with customers before field maintenance.

	Problem	Solution
1	Unit will not start	Page 52-53
2	The power switch is on but fans will not start	Page 52-53
3	The temperature on the display board cannot be set	Page 52-53
4	Unit is on but the wind is not cold(hot)	Page 52-53
5	Unit runs, but shortly stops	Page 52-53
6	The unit starts up and stops frequently	Page 52-53
7	Unit runs continuously but insufficient cooling(heating)	Page 52-53
8	Cool can not change to heat	Page 52-53
9	Unit is noisy	Page 52-53

3.2 Field maintenance

	Problem	Solution
1	Unit will not start	Page 54-55
2	Compressor will not start but fans run	Page 54-55
3	Compressor and condenser (outdoor) fan will not start	Page 54-55
4	Evaporator (indoor) fan will not start	Page 54-55
5	Condenser (Outdoor) fan will not start	Page 54-55
6	Unit runs, but shortly stops	Page 54-55
7	Compressor short-cycles due to overload	Page 54-55
8	High discharge pressure	Page 54-55
9	Low discharge pressure	Page 54-55
10	High suction pressure	Page 54-55
11	Low suction pressure	Page 54-55
12	Unit runs continuously but insufficient cooling	Page 54-55
13	Too cool	Page 54-55
14	Compressor is noisy	Page 54-55
15	Horizontal louver can not revolve	Page 54-55

1.Remote Maintenance	Electrical Circuit					Refrigerant Circuit								
Possible causes of trouble	Power failure	The main power tripped	Loose connections	Faulty transformer	The voltage is too high or too low	The remote control is powered off	Broken remote control	Dirty air filter	Dirty condenser fins	The setting temperature is higher/lower than the room's (cooling/heating)	The ambient temperature is too high/low when the mode is cooling/heating	Fan mode	SILENCE function is activated (optional function)	Frosting and defrosting frequently
Unit will not start	☆	☆	☆	☆										
The power switch is on but fans will not start			☆	☆	☆									
The temperature on the display board cannot be set						☆	☆							
Unit is on but the wind is not cold(hot)										☆	☆	☆		
Unit runs, but shortly stops					☆					☆	☆			
The unit starts up and stops frequently					☆						☆			☆
Unit runs continuously but insufficient cooling(heating)								☆	☆	☆	☆		☆	
Cool can not change to heat														
Unit is noisy														
Test method / remedy	Test voltage	Close the power switch	Inspect connections - tighten	Change the transformer	Test voltage	Replace the battery of the remote control	Replace the remote control	Clean or replace	Clean	Adjust the setting temperature	Turn the AC later	Adjust to cool mode	Turn off SILENCE function.	Turn the AC later

Others										
Check heat load						☆				Heavy load condition
Tighten bolts or screws	☆									Loosen hold down bolts and / or screws
Close all the windows and doors						☆				Bad airproof
Remove the obstacles						☆				The air inlet or outlet of either unit is blocked
Reconnect the power or press ON/OFF button on remote control to restart									☆	Interference from cell phone towers and remote boosters
Remove them	☆									Shipping plates remain attached

2.Field Maintenance		Electrical Circuit													
Possible causes of trouble															
	Power failure	Blown fuse or varistor	Loose connections	Shorted or broken wires	Safety device opens	Faulty thermostat / room temperature sensor	Wrong setting place of temperature sensor	Faulty transformer	Shorted or open capacitor	Faulty magnetic contactor for compressor	Faulty magnetic contactor for fan	Low voltage	Faulty stepping motor	Shorted or grounded compressor	Shorted or grounded fan motor
Unit will not start	☆	☆	☆	☆	☆			☆							
Compressor will not start but fans run				☆		☆			☆	☆				☆	
Compressor and condenser (outdoor) fan will not start				☆		☆				☆					
Evaporator (indoor) fan will not start				☆					☆		☆				☆
Condenser (Outdoor) fan will not start				☆		☆			☆		☆				☆
Unit runs, but shortly stops										☆		☆			
Compressor short-cycles due to overload										☆		☆			
High discharge pressure															
Low discharge pressure															
High suction pressure															
Low suction pressure															
Unit runs continuously but insufficient cooling															
Too cool						☆	☆								
Compressor is noisy															
Horizontal louver can not revolve			☆	☆									☆		
Test method / remedy															
	Test voltage														
Inspect fuse type & size															
Inspect connections - tighten															
Test circuits with tester															
Test continuity of safety device															
Test continuity of thermostat / sensor & wiring															
Place the temperature sensor at the central of the air inlet grille															
Check control circuit with tester															
Check capacitor with tester															
Test continuity of coil & contacts															
Test continuity of coil & contacts															
Test voltage															
Replace the stepping motor															
Check resistance with multimeter															
Check resistance with multimeter															

Refrigerant Circuit												Others
Replace the compressor												Compressor stuck
Leak test												Shortage of refrigerant
Replace restricted part												Restricted liquid line
Clean or replace												Dirty air filter
Clean coil												Dirty evaporator coil
Check fan												Insufficient air through evaporator coil
Change charged refrigerant volume												Overcharge of refrigerant
Clean condenser or remove obstacle												Dirty or partially blocked condenser
Purge, evacuate and recharge												Air or incompressible gas in refrigerant cycle
Remove obstruction to air flow												Short cycling of condensing air
Remove obstruction in air or water flow												High temperature condensing medium
Remove obstruction in air or water flow												Insufficient condensing medium
Replace compressor												Broken compressor internal parts
Test compressor efficiency												Inefficient compressor
Replace valve												Expansion valve obstructed
Replace valve												Expansion valve or capillary tube closed completely
Replace valve												Leaking power element on expansion valve
Fix feeler bulb												Poor installation of feeler bulb
Check heat load												Heavy load condition
Tighten bolts or screws												Loosen hold down bolts and / or screws
Remove them												Shipping plates remain attached
Choose AC of larger capacity or add the number of AC												Poor choices of capacity
Rectify piping so as not to contact each other or with external plate												Contact of piping with other piping or external plate

4. Quick Maintenance by Error Code

If you do not have the time to test whether specific parts are faulty, you can directly change the required parts according to the error code.

You can find the parts to replace by error code in the following table.

Part requiring replacement	Error Code								
	E0	ER	E1	E3	E4	E5	EB	EF	F0
Indoor PCB	✓	✓	✓	✓	✓	✓	✓	x	x
Outdoor PCB	x	x	✓	x	x	x	x	x	✓
Display Board	x	x	x	x	x	x	✓	x	x
Reactor	x	x	✓	x	x	x	x	x	x
Indoor fan motor	x	x	x	✓	x	x	x	x	x
Outdoor fan motor	x	x	x	x	x	x	x	x	x
Temperature sensor	x	x	x	x	✓	✓	x	x	x
T2 Sensor	x	x	x	x	x	x	x	x	x
Additional refrigerant	x	x	x	x	x	x	x	x	x
Compressor	x	x	x	x	x	x	x	x	✓
IPM board	x	x	x	x	x	x	x	x	x
Outdoor unit	x	x	x	x	x	x	x	x	✓
Intelligent Eye	x	x	x	x	x	x	x	✓	x

Part requiring replacement	Error Code								
	F1	F2	F3	F4	F5	P0	P1	P2	P4
Indoor PCB	x	x	x	x	x	x	x	x	x
Outdoor PCB	✓	✓	✓	✓	✓	✓	✓	✓	✓
Display Board	x	x	x	x	x	x	x	x	x
Reactor	x	x	x	x	x	x	✓	x	x
Indoor fan motor	x	x	x	x	x	x	x	x	x
Outdoor fan motor	x	x	x	x	✓	x	x	x	x
Temperature sensor	✓	✓	✓	x	x	x	x	x	x
T2 Sensor	x	x	x	x	x	x	x	x	x
Additional refrigerant	x	x	x	x	x	x	x	x	x
Compressor	x	x	x	x	x	✓	x	x	✓
IPM board	x	x	x	x	x	✓	✓	x	✓

Outdoor unit	x	x	x	x	x	x	x	x	x
Intelligent Eye	x	x	x	x	x	x	x	x	x

5. Troubleshooting by Error Code

5.1 Common Check Procedures

5.1.1 Temperature Sensor Check

Disconnect the temperature sensor from PCB, measure the resistance value with a tester.

Temperature Sensors.

Room temp.(T1) sensor,

Indoor coil temp.(T2) sensor,

Outdoor coil temp.(T3) sensor,

Outdoor ambient temp.(T4) sensor,

Compressor discharge temp.(Tp) sensor.

Measure the resistance value of each winding by using the multi-meter.

5.1.2 Compressor checking

Measure the resistance value of each winding by using the tester.

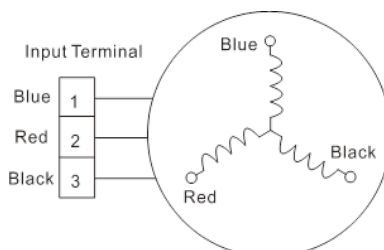

Position	Resistance Value
	ATM115D43UFZ2
Blue - Red	1.87Ω(20°C/68°F)
Blue - Black	
Red - Blue	



5.1.3 IPM Continuity Check

Turn off the power, let the large capacity electrolytic capacitors discharge completely, and dismantle the IPM. Use a digital tester to measure the resistance between P and UVWN; UVW and N.

Digital tester		Normal resistance value	Digital tester		Normal resistance value
(+)Red	(-)Black		(+)Red	(-)Black	
P	N	∞ (Several MΩ)	U	N	∞ (Several MΩ)
	U		V		
	V		W		
	W		(+)Red		

5.2 E0/F4/EA (EEPROM parameter error)

Description: Indoor or outdoor PCB main chip does not receive feedback from EEPROM chip.

Recommended parts to prepare:

- Indoor PCB
- Outdoor PCB

Troubleshooting and repair:

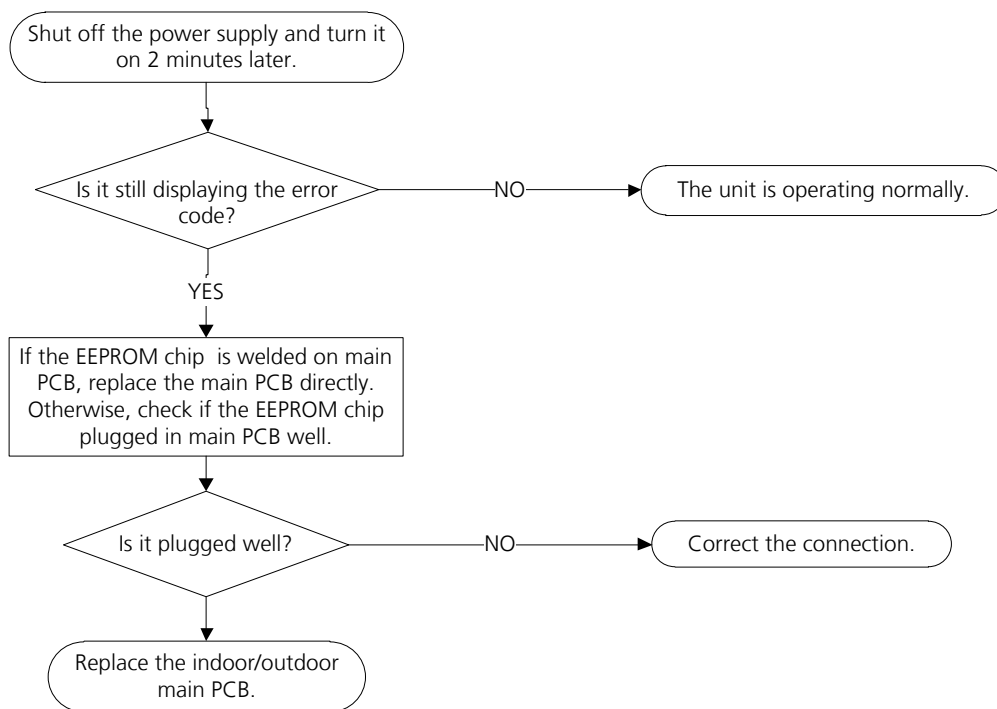

Remarks:

The location of the EEPROM chip on the indoor and outdoor PCB is shown in the following two images:

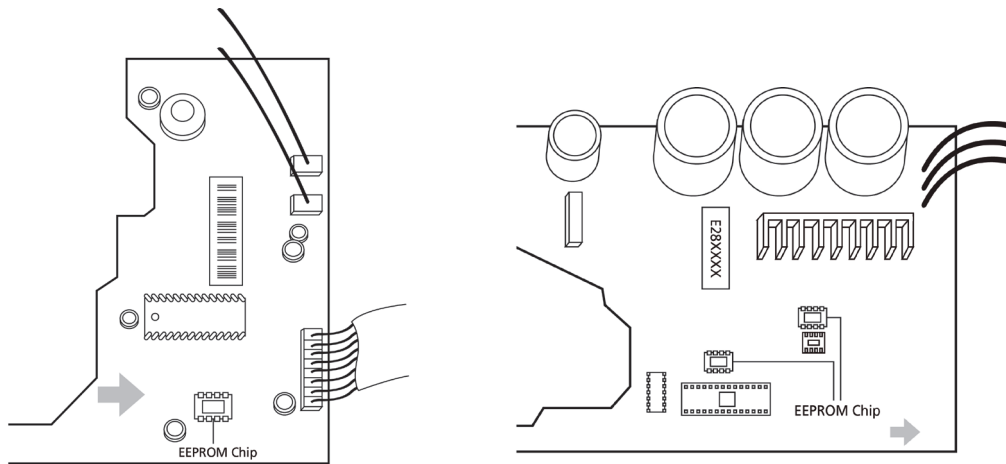

Note: These images are for reference only.

5.3 E1 (Indoor and outdoor unit communication error)

Description: The indoor unit has not received feedback from the outdoor unit for 150 seconds, four consecutive times.

Recommended parts to prepare:

- Indoor PCB
- Outdoor PCB
- Reactor

Troubleshooting and repair:

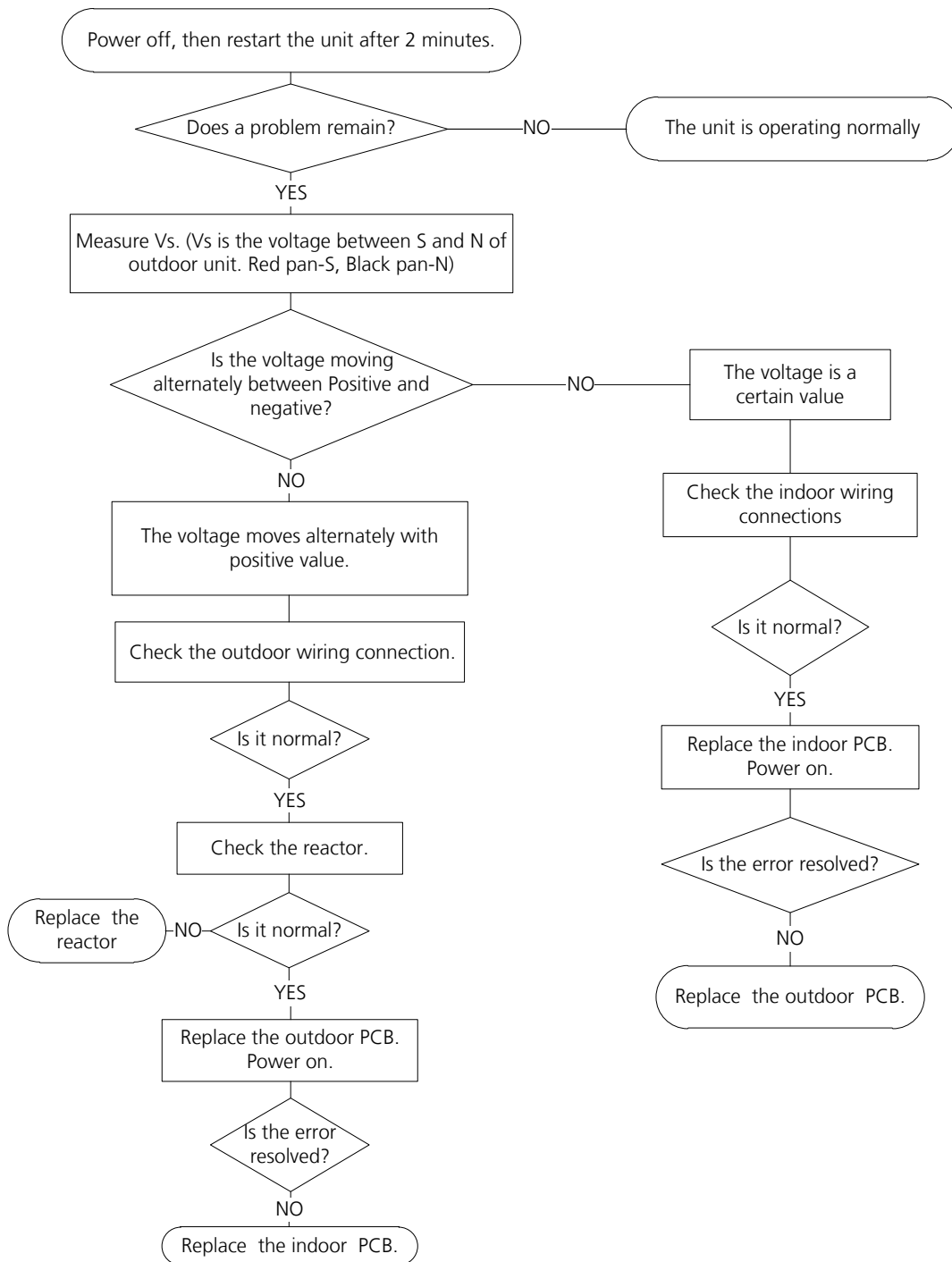

Remarks:

- Use a multimeter to test the DC voltage between 2 port and 3 port of outdoor unit. The red pin of multimeter connects with 2 port while the black pin is for 3 port.
- When AC is normal running, the voltage is moving alternately as positive values and negative values.
- If the outdoor unit has malfunction, the voltage has always been the positive value.
- While if the indoor unit has malfunction, the voltage is a fixed value.

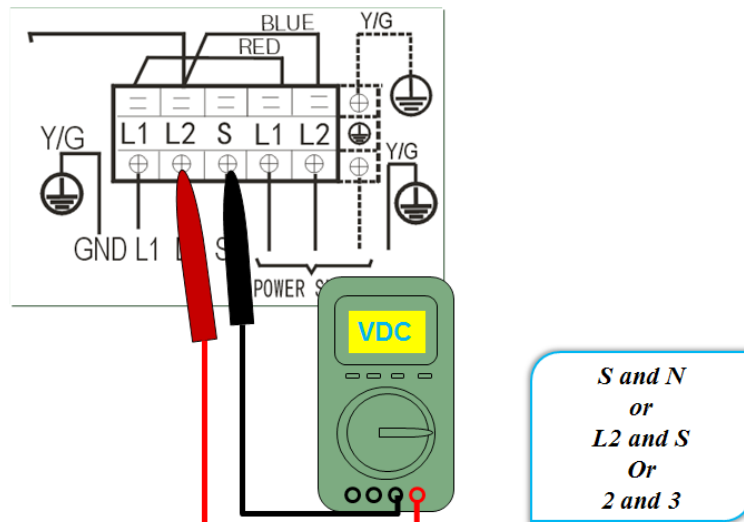

- Use a multimeter to test the resistance of the reactor which does not connect with capacitor.
- The normal value should be around zero ohm. Otherwise, the reactor must have malfunction.



5.4 E3/F5(Fan speed is operating outside of the normal range)

Description: When the indoor fan speed keeps too low (300RPM) or too high (1500RPM) for certain time, the unit will stop and the LED will display the failure(E3). When the outdoor fan speed registers below 200RPM or over 1500RPM for an extended period of time, the unit will stop and the LED will display the failure(F5).

Recommended parts to prepare:

- Wiring mistake
- Faulty fan assembly
- Faulty fan motor
- Faulty PCB

Troubleshooting and repair:

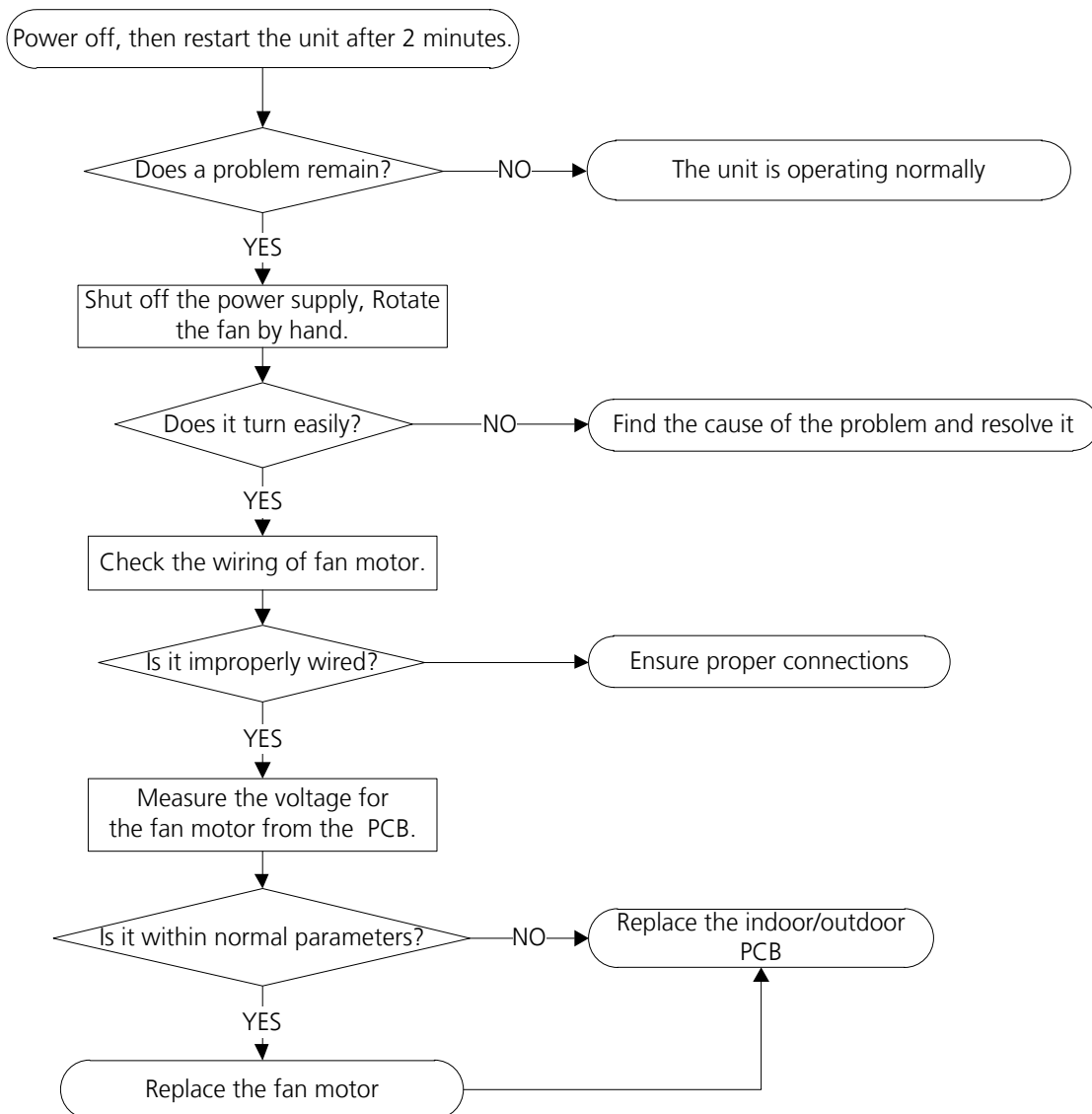

Index:

1. Indoor or Outdoor DC Fan Motor(control chip is in fan motor)

Power on and when the unit is in standby, measure the voltage of pin1-pin3, pin4-pin3 in fan motor connector. If the value of the voltage is not in the range showing in below table, the PCB must has problems and need to be replaced.

- DC motor voltage input and output (voltage: 220-240V~):

No.	Color	Signal	Voltage
1	Red	Vs/Vm	280V~380V
2	---	---	---
3	Black	GND	0V
4	White	Vcc	14-18.5V
5	Yellow	Vsp	0~5.6V
6	Blue	FG	14-18.5V

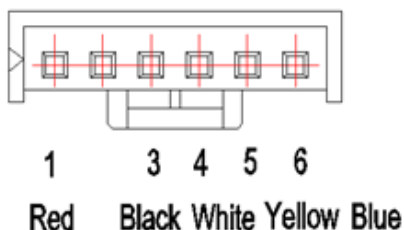

2. Outdoor DC Fan Motor (control chip is in outdoor PCB)

Power on ,and check if the fan can run normally, if the fan can run normally, the PCB must has problems and need to be replaced, If the fan can't run normally, measure the resistance of each two pins. If the resistance is not equal to each other, the fan motor must have problems and need to be replaced, otherwise the PCB must has problems and need to be replaced.

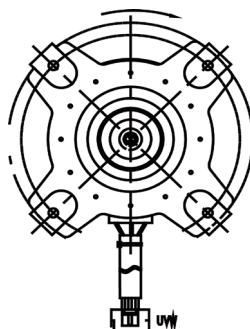

3. Indoor AC Fan Motor

Power on and set the unit running in fan mode at high fan speed. After running for 15 seconds, measure the voltage of pin1 and pin2. If the value of the voltage is less than 100V(208~240V power supply) or 50V(115V power supply), the PCB must has problems and need to be replaced.

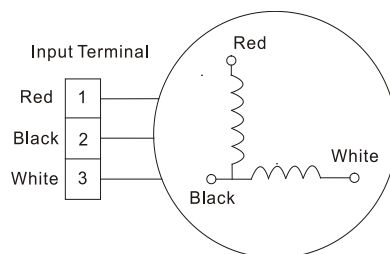

5.5 EF (Intelligent eye module error diagnosis and solution)

Description: If the intelligent eye module malfunctions, the LED will display the failure.

Recommended parts to prepare:

- Intelligent eye

Troubleshooting and repair:

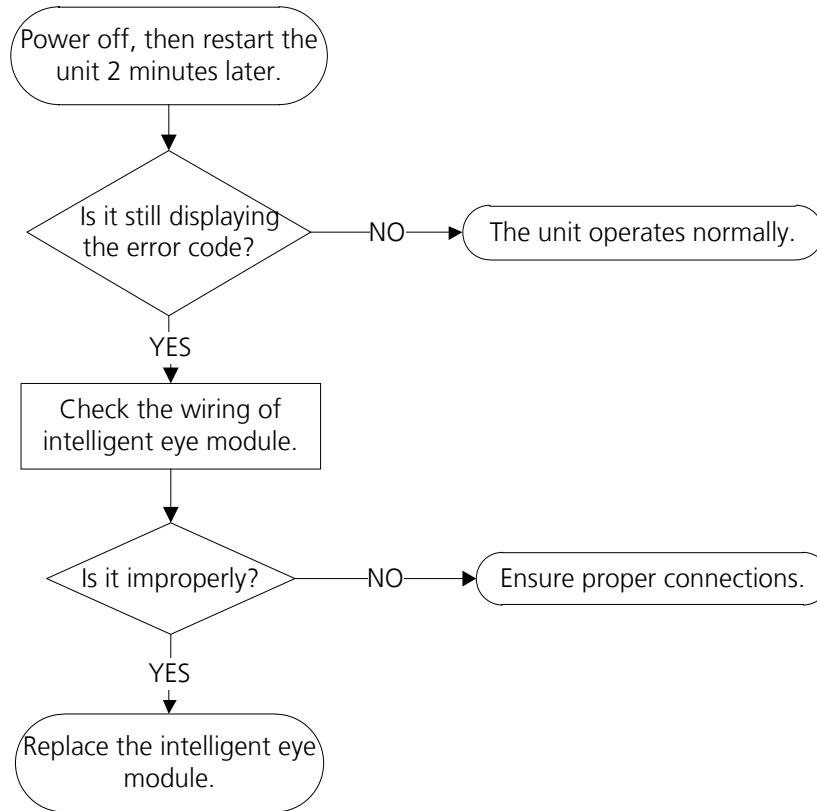

5.6 E4/E5/F1/F2/F3 (Open circuit or short circuit of temperature sensor diagnosis and solution)

Description: If the sampling voltage is lower than 0.06V or higher than 4.94V, the LED will display the failure.

Recommended parts to prepare:

- Wiring mistake
- Faulty sensor
- Faulty PCB

Troubleshooting and repair:

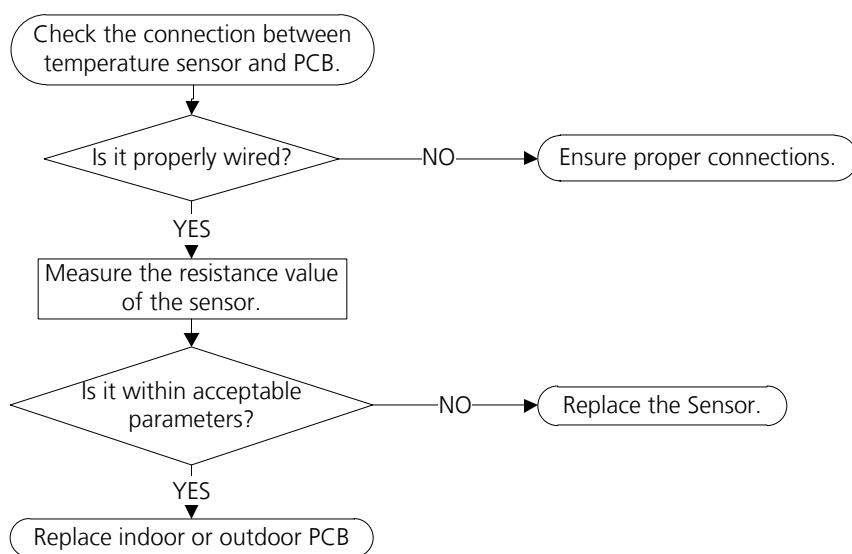

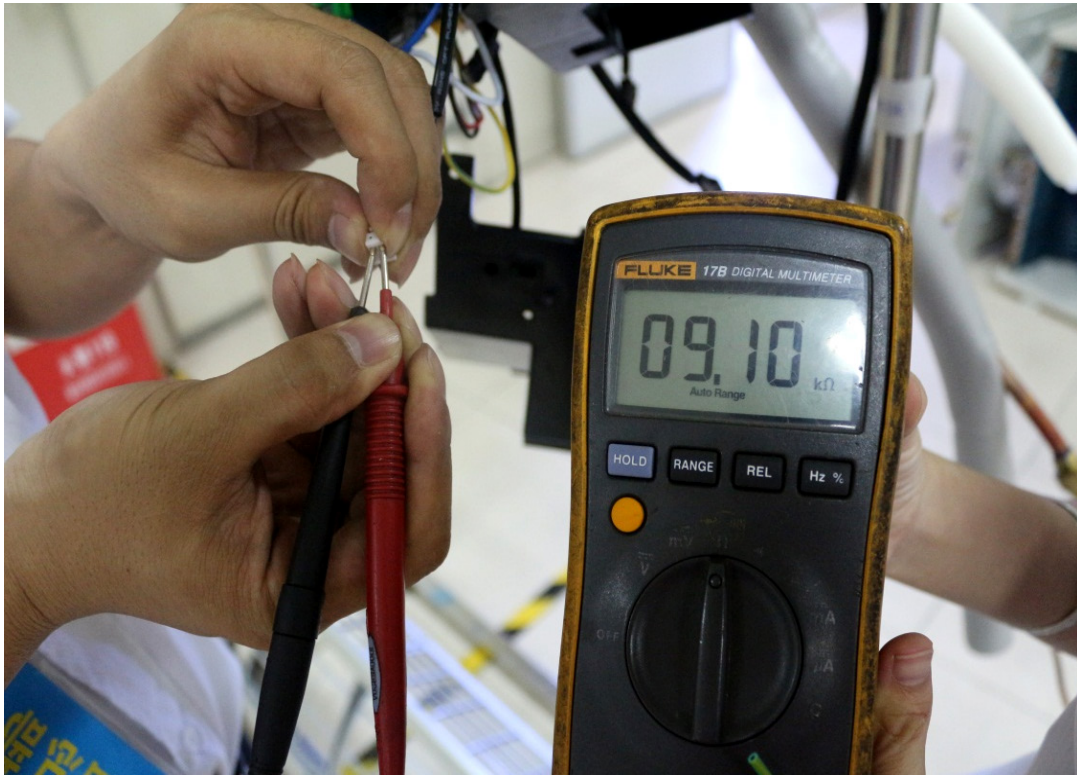

5.7 Eb (Communication error between the indoor PCB and display board)

Description: Indoor PCB does not receive feedback from Display board.

Recommended parts to prepare:

- Wiring mistake
- PCB faulty
- Display board malfunction

Troubleshooting and repair:

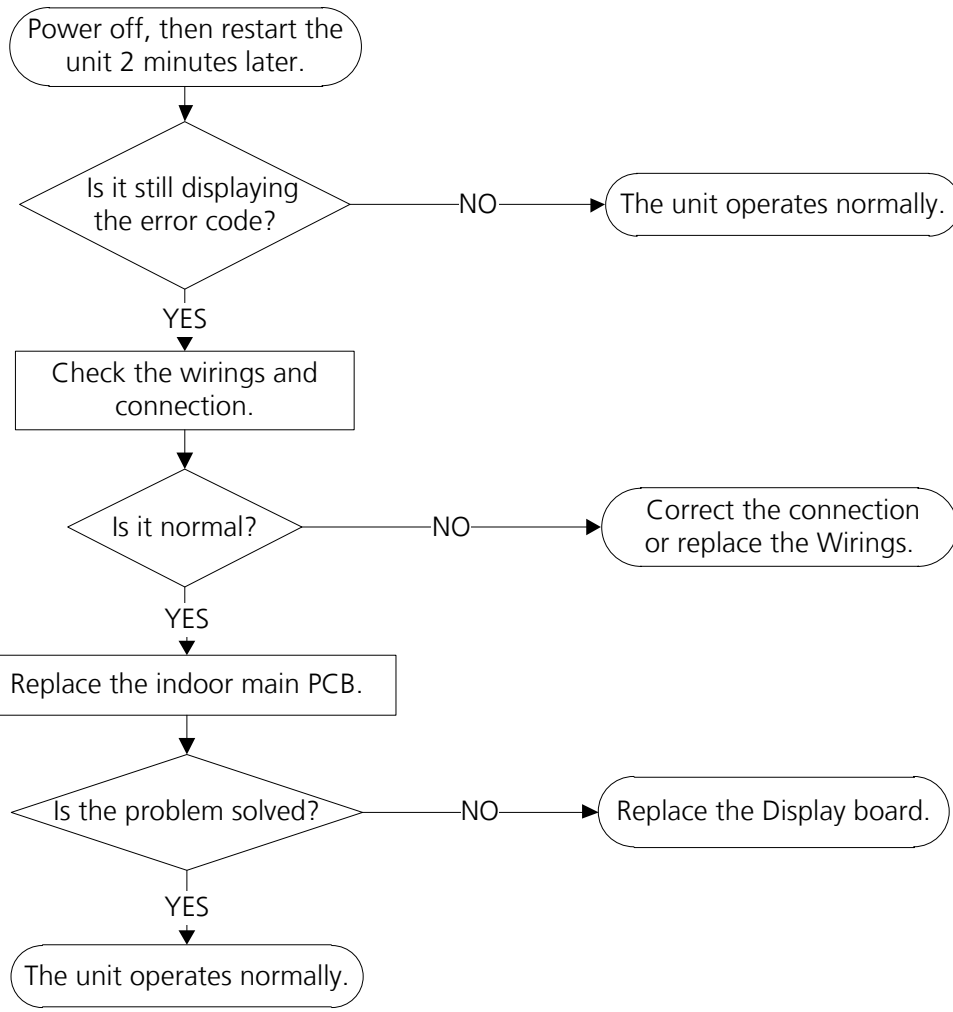

5.8 F0(Overload current protection diagnosis and solution)

Description: An abnormal current rise is detected by checking the specified current detection circuit.

Recommended parts to prepare:

- Power supply problems.
- System blockage
- Faulty PCB
- Wiring mistake
- Compressor malfunction

Troubleshooting and repair:

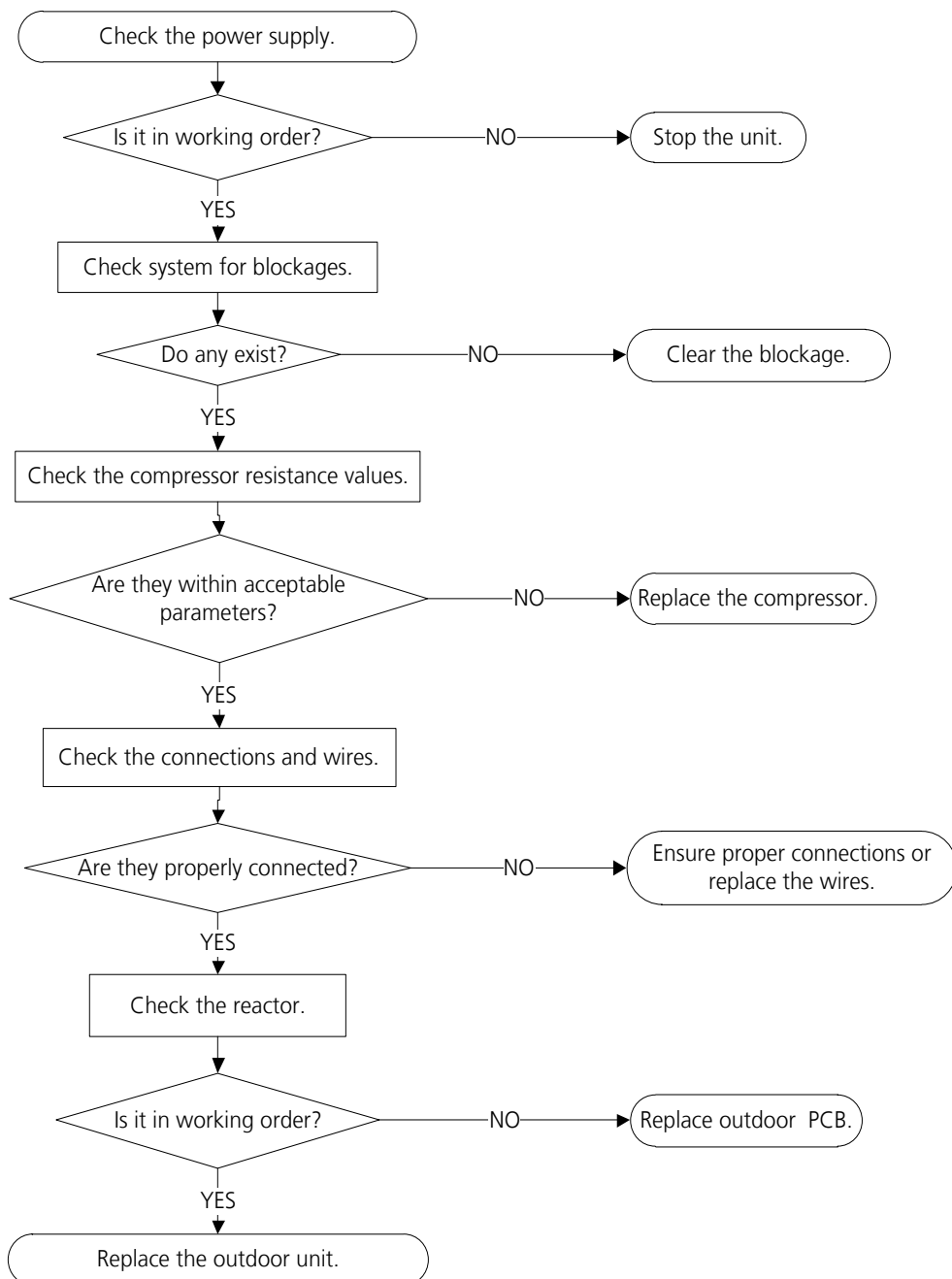

5.9 P0(IPM malfunction or IGBT over-strong current protection diagnosis and solution)

Description: When the voltage signal the IPM sends to the compressor drive chip is abnormal, the display LED shows “P0” and the AC turn off.

Recommended parts to prepare:

- Wiring mistake
- IPM malfunction
- Faulty outdoor fan assembly
- Compressor malfunction
- Faulty outdoor PCB

Troubleshooting and repair:

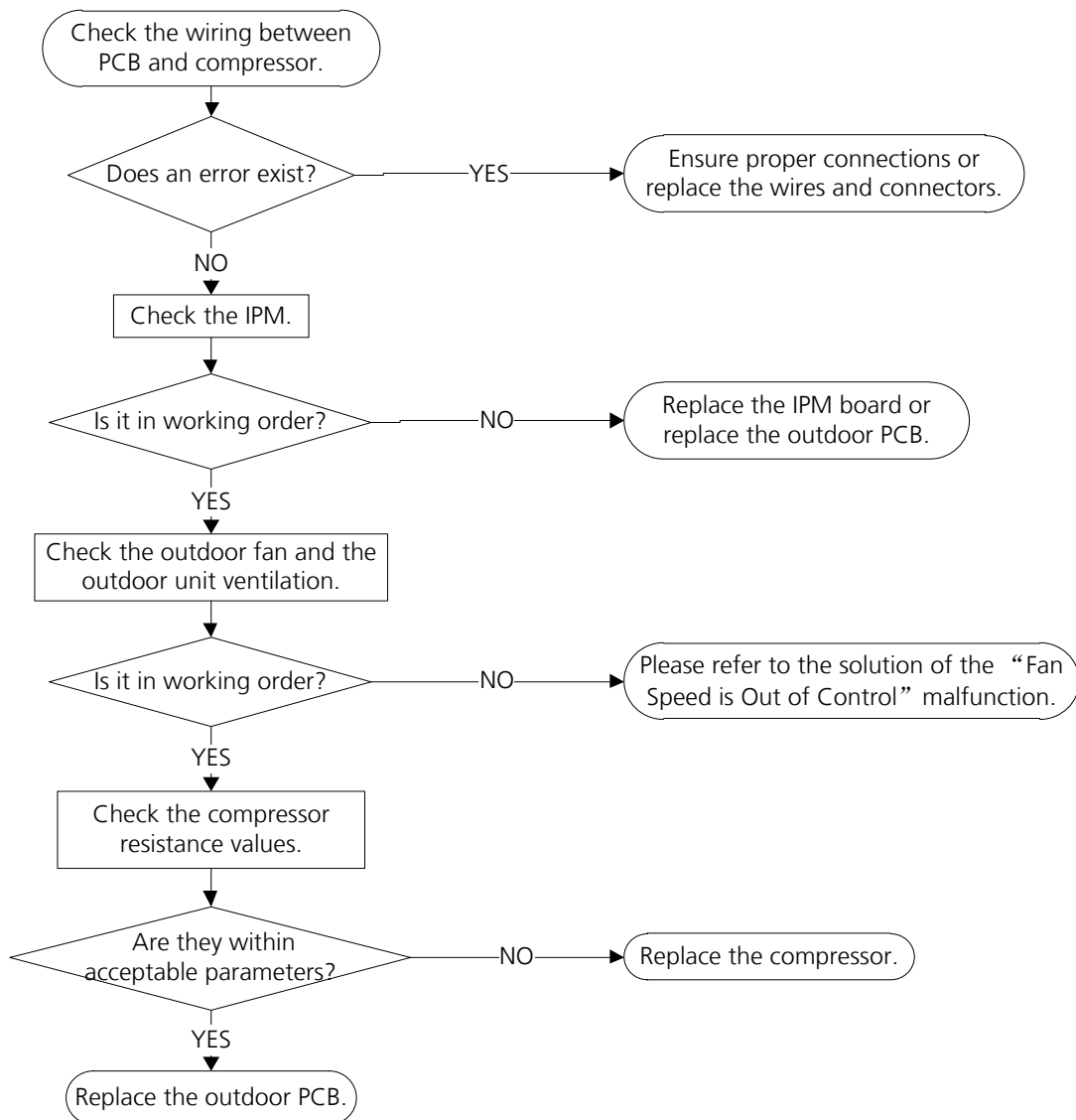

5.10 P1(Over voltage or too low voltage protection diagnosis and solution)

Description: Abnormal increases or decreases in voltage are detected by checking the specified voltage detection circuit.

Recommended parts to prepare:

- Power supply issues
- System leakage or blockage
- Faulty PCB

Troubleshooting and repair:

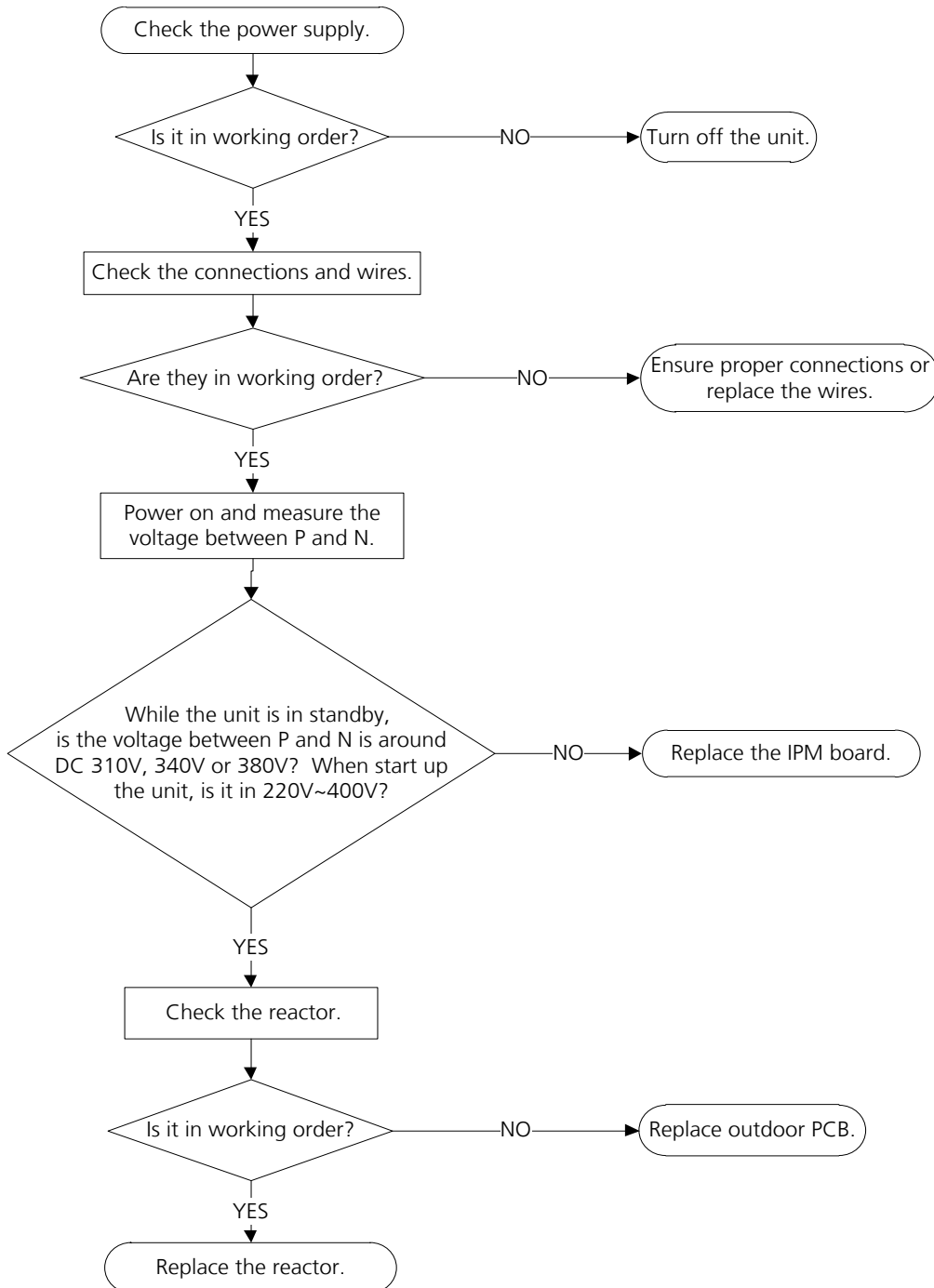

Remark:

- Measure the DC voltage between P and N port. The normal value should be around 310V.

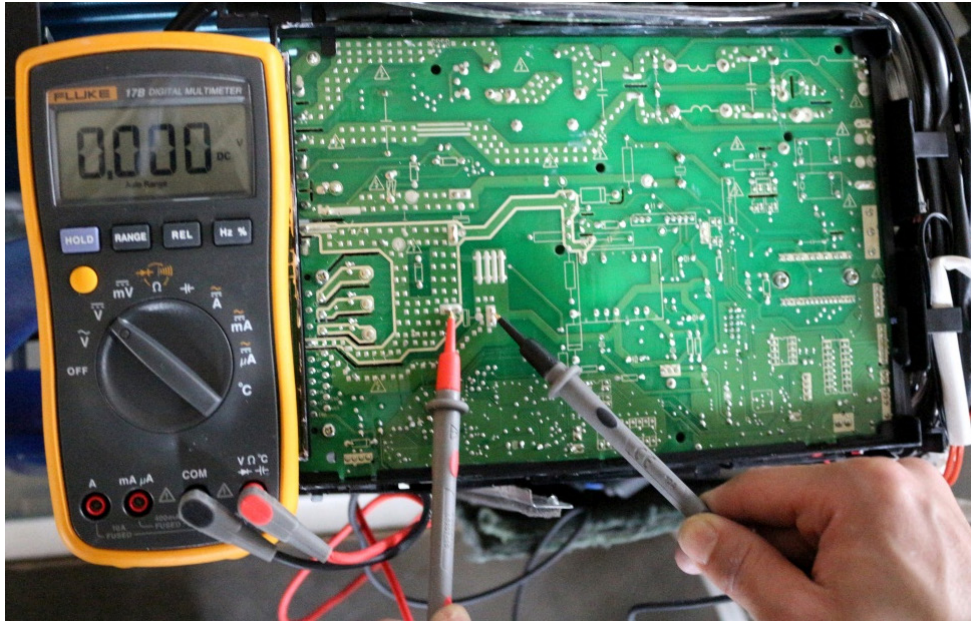

5.13 Compressor driven chip EEPROM parameter error diagnosis and solution

Description: Outdoor PCB main chip does not receive feedback from compressor driven EEPROM chip.

Recommended parts to prepare:

- Outdoor PCB

Troubleshooting and repair:

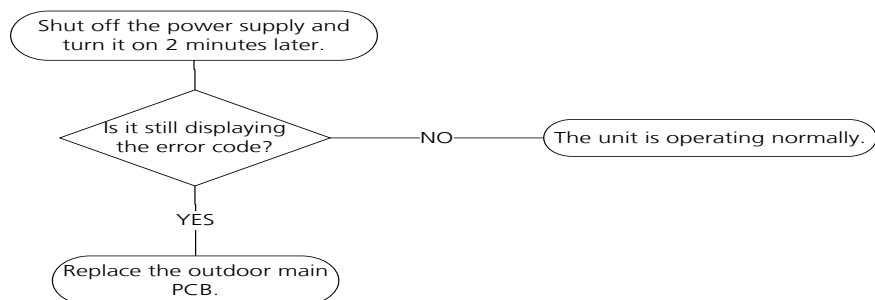

5.14 Zero speed protection of compressor/ outdoor fan or lack of phase of compressor or outdoor fan/Compressor speed malfunction diagnosis and solution

Recommended parts to prepare:

- Wiring mistake
- Faulty fan assembly faulty
- Faulty fan motor
- Faulty PCB
- Faulty compressor

Troubleshooting and repair:

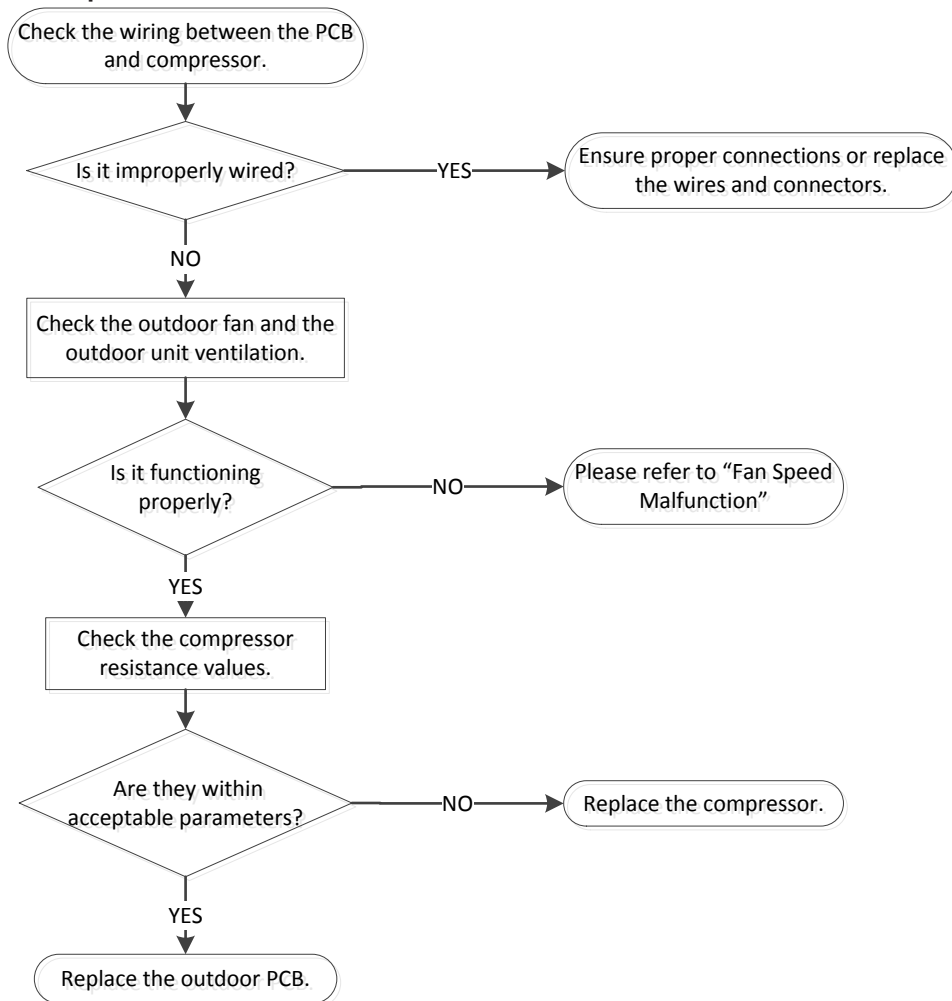

5.15 Communication error between outdoor main chip and compressor driven chip diagnosis and solution

Recommended parts to prepare:

- Faulty PCB

Troubleshooting and repair:

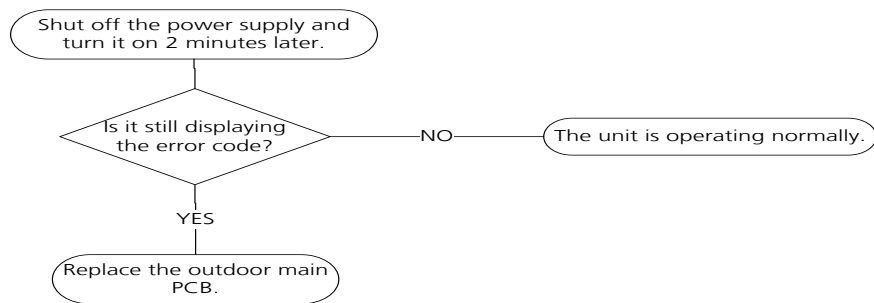

5.16 IGBT over-strong current protection diagnosis and solution

Recommended parts to prepare:

- Faulty IGBT
- Faulty outdoor PCB

Troubleshooting and repair:

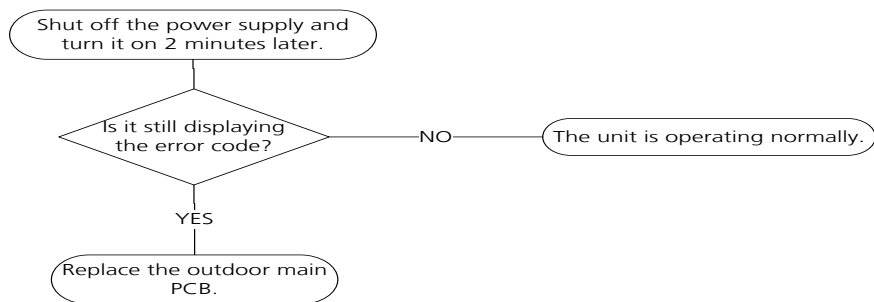

Appendix

Contents

i)	Temperature Sensor Resistance Value Table for T1, T2, T3, and T4 (°C – K)	78
ii)	Temperature Sensor Resistance Value Table for TP (°C – K).....	79
iii)	$\Delta T(^{\circ}F)=(9\Delta T(^{\circ}C))/5+32$	80
iv)	Pressure On Service Port	81
v)	Temperature Humidity Characteristics	83

5.11 P2(High temperature protection of IPM module diagnosis and solution)

Description: If the temperature of IPM module is higher than limited value, the LED displays this failure code.

Recommended parts to prepare:

- Faulty PCB
- Connection problems

Troubleshooting and repair:

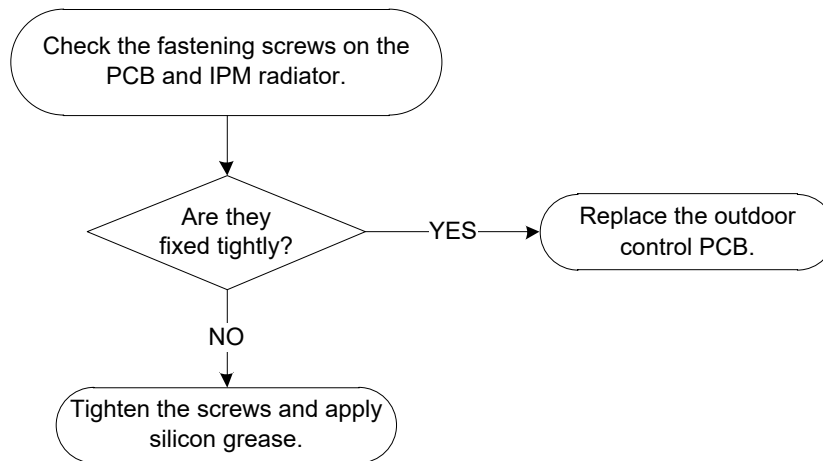

5.12 P4(Inverter compressor drive error diagnosis and solution)

Description: An abnormal inverter compressor drive is detected by a special detection circuit, including communication signal detection, voltage detection, compressor rotation speed signal detection and so on.

Recommended parts to prepare:

- Wiring mistake
- IPM malfunction
- Faulty outdoor fan assembly
- Compressor malfunction
- Faulty outdoor PCB

Troubleshooting and repair:

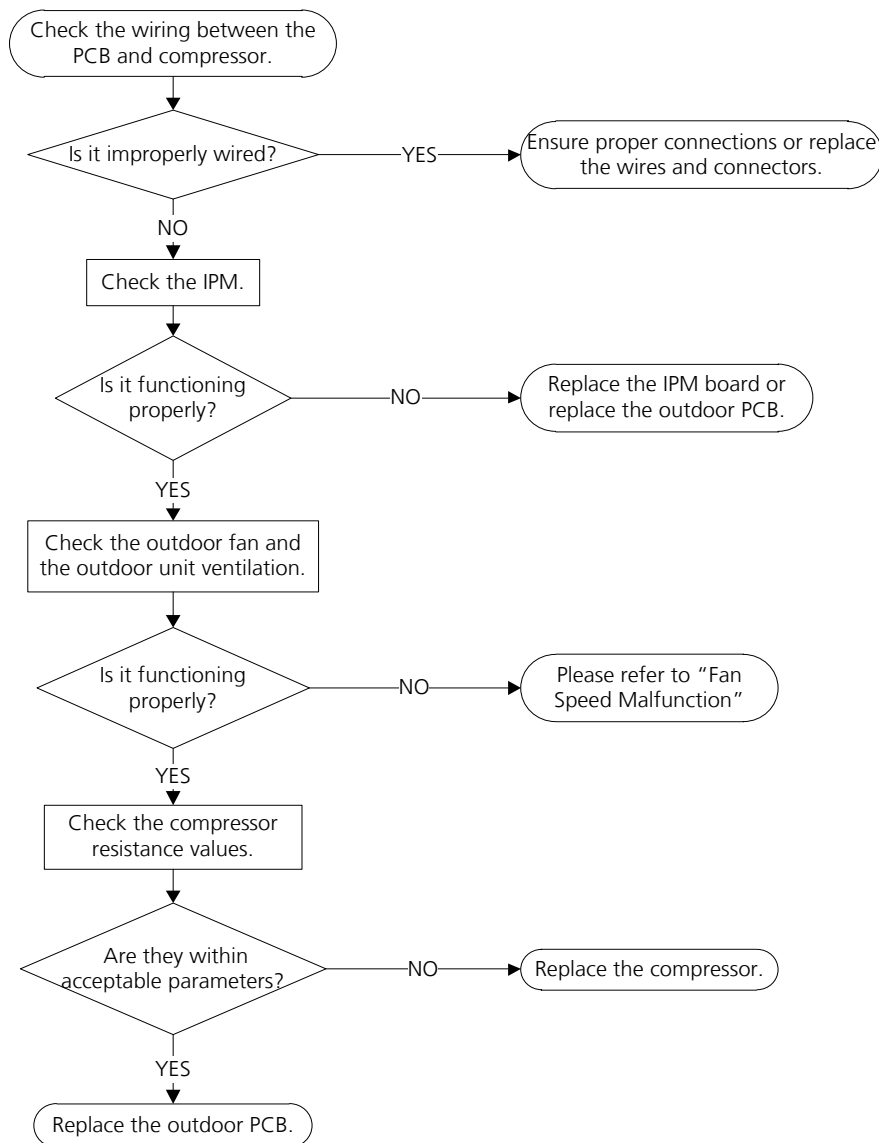

iii) $\Delta T(^{\circ}\text{F}) = (9\Delta T(^{\circ}\text{C}))/5 + 32$

$^{\circ}\text{C}$	$^{\circ}\text{F}$	$^{\circ}\text{C}$	$^{\circ}\text{F}$	$^{\circ}\text{C}$	$^{\circ}\text{F}$	$^{\circ}\text{C}$	$^{\circ}\text{F}$	$^{\circ}\text{C}$	$^{\circ}\text{F}$
-5	23	21	69.8	51	123.8	82	179.6	113	235.4
-4	24.8	22	71.6	52	125.6	83	181.4	114	237.2
-3	26.6	23	73.4	53	127.4	84	183.2	115	239
-2	28.4	24	75.2	54	129.2	85	185	116	240.8
-1	30.2	25	77	55	131	86	186.8	117	242.6
0	32	25.5	77.9	56	132.8	87	188.6	118	244.4
0.5	32.9	26	78.8	57	134.6	88	190.4	119	246.2
1	33.8	27	80.6	58	136.4	89	192.2	120	248
1.5	34.7	28	82.4	59	138.2	90	194	121	249.8
2	35.6	29	84.2	60	140	91	195.8	122	251.6
2.5	36.5	30	86	61	141.8	92	197.6	123	253.4
3	37.4	31	87.8	62	143.6	93	199.4	124	255.2
3.5	38.3	32	89.6	63	145.4	94	201.2	125	257
4	39.2	33	91.4	64	147.2	95	203	126	258.8
4.5	40.1	34	93.2	65	149	96	204.8	127	260.6
5	41	35	95	66	150.8	97	206.6	128	262.4
6	42.8	36	96.8	67	152.6	98	208.4	129	264.2
7	44.6	37	98.6	68	154.4	99	210.2	130	266
8	46.4	38	100.4	69	156.2	100	212	131	267.8
9	48.2	39	102.2	70	158	101	213.8	132	269.6
10	50	40	104	71	159.8	102	215.6	133	271.4
11	51.8	41	105.8	72	161.6	103	217.4	134	273.2
12	53.6	42	107.6	73	163.4	104	219.2	135	275
13	55.4	43	109.4	74	165.2	105	221	136	276.8
14	57.2	44	111.2	75	167	106	222.8	137	278.6
15	59	45	113	76	168.8	107	224.6	138	280.4
16	60.8	46	114.8	77	170.6	108	226.4	139	282.2
17	62.6	47	116.6	78	172.4	109	228.2	140	284
18	64.4	48	118.4	79	174.2	110	230	141	285.8
19	66.2	49	120.2	80	176	111	231.8	142	287.6
20	68	50	122	81	177.8	112	233.6	143	289.4

iv) Pressure On Service Port

Cooling chart(R410A):

°F(°C)	ODU(DB)		0(-17)	5(-15)	15 (9.44)	45 (7.22)	75 (23.89)	85 (29.44)	95 (35)	105 (40.56)	115 (46.11)	120 (48.89)
	IDU(DB/WB)											
BAR	70/59 (21.11/15)		6.4	6.5	7.3	8.0	8.2	7.8	8.1	8.6	10.1	10.6
	75/63 (23.89/17.22)		6.7	6.8	7.9	8.6	8.6	8.3	8.7	9.1	10.7	11.2
	80/67 (26.67/19.44)		7.1	7.2	8.5	9.5	9.3	8.9	9.1	9.6	11.2	11.9
	90/73 (32.22/22.78)		7.7	7.8	9.6	10.5	10.3	9.5	10.0	10.6	12.4	13.0
PSI	70/59 (21.11/15)		93	94	106	116	119	113	117	125	147	154
	75/63 (23.89/17.22)		97	99	115	125	124	120	126	132	155	162
	80/67 (26.67/19.44)		103	104	123	138	135	129	132	140	162	173
	90/73 (32.22/22.78)		112	113	139	152	149	138	145	154	180	189
MPa	70/59 (21.11/15)		0.64	0.65	0.73	0.8	0.82	0.78	0.81	0.86	1.01	1.06
	75/63 (23.89/17.22)		0.67	0.68	0.79	0.86	0.86	0.83	0.87	0.91	1.07	1.12
	80/67 (26.67/19.44)		0.71	0.72	0.85	0.95	0.93	0.89	0.91	0.96	1.12	1.19
	90/73 (32.22/22.78)		0.77	0.78	0.96	1.05	1.03	0.95	1	1.06	1.24	1.3

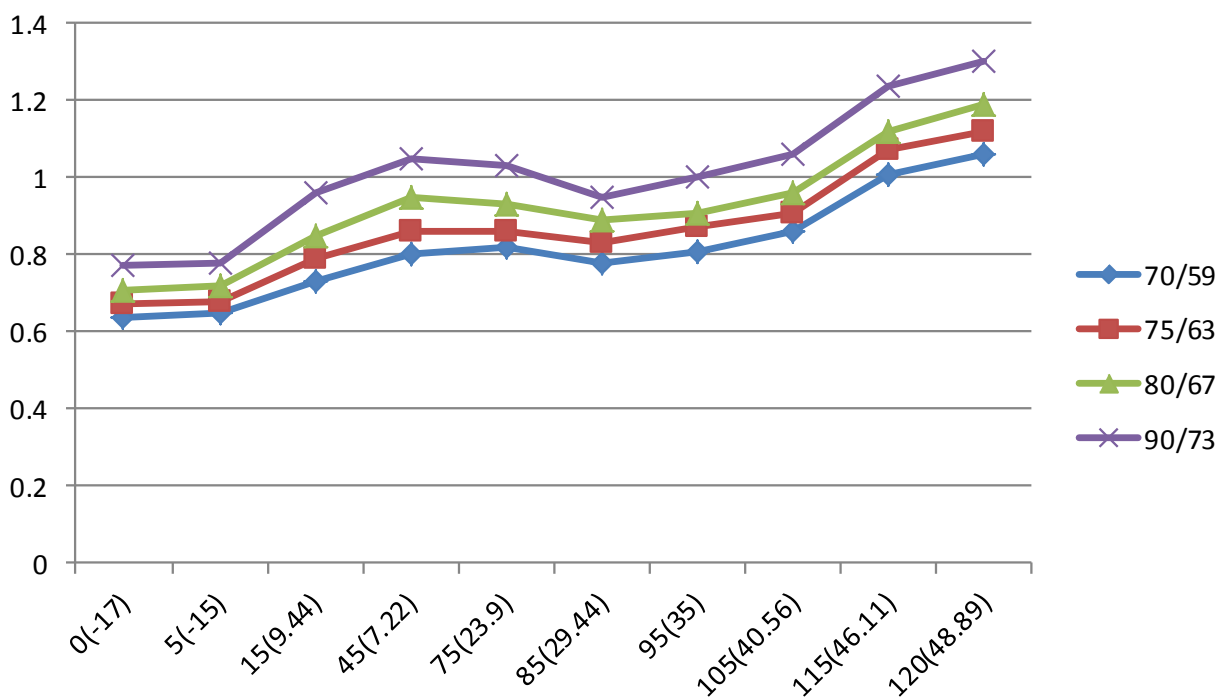

Heating chart(R410A):

°F(°C)	ODU(DB/WB)	57/53 (13.89/11.67)	47/43 (8.33/6.11)	37/33 (2.78/0.56)	27/23 (-2.78/-5)	17/13 (-8.33/ -10.56)	0/-2 (-17/-19)	-17/-18 (-27/-28)
	IDU(DB)							
BAR	55(12.78)	30.3	28.5	25.3	22.8	20.8	18.5	16.5
	65(18.33)	32.5	30.0	26.6	25.4	23.3	20.5	19.0
	75(23.89)	33.8	31.5	27.8	26.3	24.9	21.5	20.0
PSI	55(12.78)	439	413	367	330	302	268	239
	65(18.33)	471	435	386	368	339	297	276
	75(23.89)	489	457	403	381	362	312	290
MPa	55(12.78)	3.03	2.85	2.53	2.28	2.08	1.85	1.65
	65(18.33)	3.25	3.00	2.66	2.54	2.33	2.05	1.90
	75(23.89)	3.38	3.15	2.78	2.63	2.49	2.15	2.00

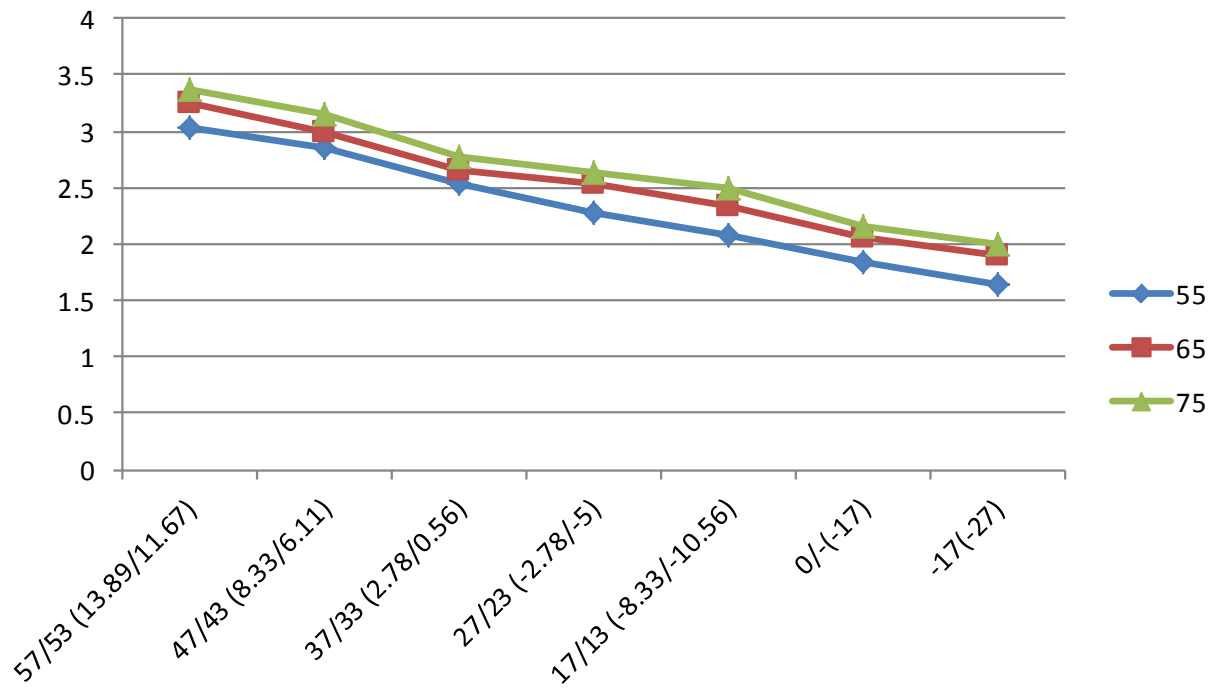

v) Temperature Humidity Characteristics

Unit:kOhm

Temp. °C(°F)	Relative Humidity(%RH)									
	10	20	30	40	50	60	70	80	90	95
0(32)	13,000,000	128,688	7,854	1198.7	315.2	104.59	41.05	17.81	7.73	5.28
5(41)	6,000,000	68,057	4,915	824	218.5	72.27	28.15	12.09	5.35	3.77
10(50)	2,910,000	35,993	3,076	566.4	151.4	49.94	19.3	8.21	3.7	2.72
15(59)	1,340,000	19,368	1,906	375.3	99.1	33.47	13.36	5.7	2.7	1.98
20(68)	638,000	10,780	1,130	240	68	22.7	9.6	4.33	2.08	1.55
25(77)	308,531	5,916	694	149.9	45.8	16	7	3.28	1.68	1.24
30(86)	149,710	3,450	420	94.6	31	11.3	5.2	2.6	1.42	1.06
35(95)	72,507	2,053	268	60.6	21.2	8.05	3.83	2.08	1.2	0.92
40(104)	34,261	1,235	172	41.8	15	6.11	3	1.71	1.05	0.83
45(113)	16,222	740	115	30.2	11	4.76	2.43	1.46	0.93	0.75
50(122)	7,688	446	79	22.7	8.3	3.78	2.03	1.28	0.84	0.67

