



SERVICE MANUAL

Master Model Number
FM24HIAHUU230X6

Product code
22023111000231

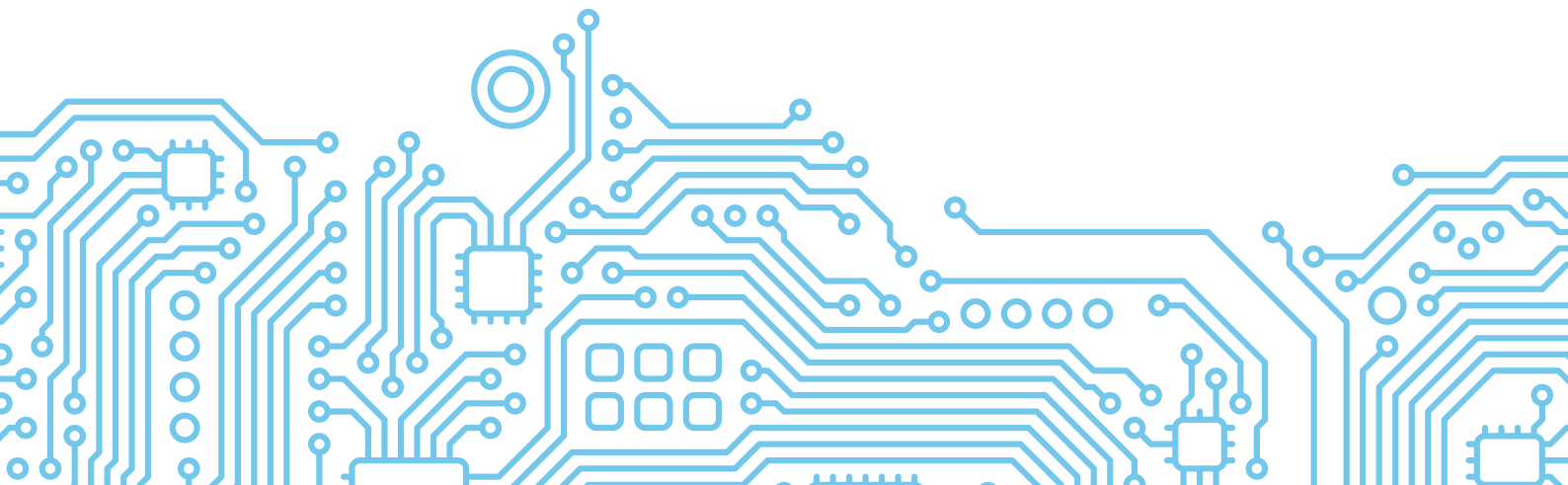

Table of Contents

§. Safety Precautions

1. Precautions
2. Information servicing

§. Model Reference & External Appearance

1. Model Reference
2. External Appearance

§. Indoor Unit

1. Indoor Unit - Air Handler Type

§. Outdoor Unit

1. Dimensional Drawings
2. Service Space
3. Capacity Correction Factor for Height Difference
4. Noise Criterion Curves
5. Refrigerant Cycle Diagrams
6. Electrical Wiring Diagrams

§. Installation

§. Maintenance

§. Product Features

Table of Contents

§. Troubleshooting

1. Safety Caution
2. General Troubleshooting
3. Outdoor Unit Point Check Function
4. Complain Record Form
5. Information Inquiry
6. Error Diagnosis and Troubleshooting Without Error Code
7. Quick Maintenance by Error Code
8. Troubleshooting by Error Code
9. Check Procedures

§. Indoor Unit Disassembly

1. Indoor Unit - Air Handler Type

§. Outdoor Unit Disassembly

Appendix

- i) Temperature Sensor Resistance Value Table for T1,T2,T3 and T4 (°C – K)
- ii) Temperature Sensor Resistance Value Table for TP(for some units) (°C – K)
- iii) Pressure On Service Port

Safety Precautions

Contents

1.	Precautions.....	2
2.	Information servicing(For flammable materials).....	3

1. Precautions

To prevent personal injury, or property or unit damage, adhere to all precautionary measures and instructions outlined in this manual. Before servicing a unit, refer to this service manual and its relevant sections.

Failure to adhere to all precautionary measures listed in this section may result in personal injury, damage to the unit or to property, or in extreme cases, death.

 **WARNING** indicates a potentially hazardous situation which if not avoided could result in serious personal injury, or death.

 **CAUTION** indicates a potentially hazardous situation which if not avoided could result in minor or moderate personal injury, or unit damage.

1.1 In case of Accidents or Emergency

 **WARNING**

- If a gas leak is suspected, immediately turn off the gas and ventilate the area if a gas leak is suspected before turning the unit on.
- If strange sounds or smoke is detected from the unit, turn the breaker off and disconnect the power supply cable.
- If the unit comes into contact with liquid, contact an authorized service center.
- If liquid from the batteries makes contact with skin or clothing, immediately rinse or wash the area well with clean water.
- Do not insert hands or other objects into the air inlet or outlet while the unit is plugged in.
- Do not operate the unit with wet hands.
- Do not use a remote controller that has previously been exposed to battery damage or battery leakage.

 **CAUTION**

- Clean and ventilate the unit at regular intervals when operating it near a stove or near similar devices.
- Do not use the unit during severe weather conditions. If possible, remove the product from the window before such occurrences.

1.2 Pre-Installation and Installation

 **WARNING**

- Use this unit only on a dedicated circuit.
- Damage to the installation area could cause the unit to fall, potentially resulting in personal injury, property damage, or product failure.
- Only qualified personnel should disassemble, install, remove, or repair the unit.
- Only a qualified electrician should perform electrical work. For more information, contact your dealer, seller, or an authorized service center.

 **CAUTION**

- While unpacking be careful of sharp edges around the unit as well as the edges of the fins on the condenser and evaporator.

1.3 Operation and Maintenance

 **WARNING**

- Do not use defective or under-rated circuit breakers.
- Ensure the unit is properly grounded and that a dedicated circuit and breaker are installed.
- Do not modify or extend the power cable. Ensure the power cable is secure and not damaged during operation.
- Do not unplug the power supply plug during operation.
- Do not store or use flammable materials near the unit.
- Do not open the inlet grill of the unit during operation.
- Do not touch the electrostatic filter if the unit is equipped with one.
- Do not block the inlet or outlet of air flow to the unit.
- Do not use harsh detergents, solvents, or similar items to clean the unit. Use a soft cloth for cleaning.
- Do not touch the metal parts of the unit when removing the air filter as they are very sharp.
- Do not step on or place anything on the unit or outdoor units.
- Do not drink water drained from the unit
- Avoid direct skin contact with water drained from the unit.
- Use a firm stool or step ladder according to manufacturer procedures when cleaning or maintaining the unit.

 **CAUTION**

- Do not install or operate the unit for an extended period of time in areas of high humidity or in an environment directly exposing it to sea wind or salt spray.
- Do not install the unit on a defective or damaged installation stand, or in an unsecure location.
- Ensure the unit is installed at a level position
- Do not install the unit where noise or air discharge created by the outdoor unit will negatively impact the environment or nearby residences.
- Do not expose skin directly to the air discharged by the unit for prolonged periods of time.
- Ensure the unit operates in areas water or other liquids.
- Ensure the drain hose is installed correctly to ensure proper water drainage.
- When lifting or transporting the unit, it is recommended that two or more people are used for this task.
- When the unit is not to be used for an extended time, disconnect the power supply or turn off the breaker.

2. Information servicing(For flammable materials)

2.1 Checks to the area

- Prior to beginning work on systems containing flammable refrigerants, safety checks are necessary to ensure that the risk of ignition is minimized.
- For repair to the refrigerating system, the following precautions shall be complied with prior to conducting work on the system.

2.2 Work procedure

- Work shall be undertaken under a controlled procedure so as to minimise the risk of a flammable gas or vapour being present while the work is being performed.

2.3 Work procedure

- All maintenance staff and others working in the local area shall be instructed on the nature of work being carried out.
- Work in confined spaces shall be avoided.
- The area around the work space shall be sectioned off. Ensure that the conditions within the area have been made safe by control of flammable material.

2.4 Checking for presence of refrigerant

- The area shall be checked with an appropriate refrigerant detector prior to and during work, to ensure the technician is aware of potentially flammable atmospheres.
- Ensure that the leak detection equipment being used is suitable for use with flammable refrigerants, i.e. no sparking, adequately sealed or intrinsically safe.

2.5 Presence of fire extinguisher

- If any hot work is to be conducted on the refrigeration equipment or any associated parts, appropriate fire extinguishing equipment shall be available to hand.
- Have a dry powder or CO₂ fire extinguisher adjacent to the charging area.

2.6 No ignition sources

- No person carrying out work in relation to a refrigeration system which involves exposing any pipe work that contains or has contained flammable refrigerant shall use any sources of ignition in such a manner that it may lead to the risk of fire or explosion.
- All possible ignition sources, including cigarette smoking, should be kept sufficiently far away from the site of installation, repairing, removing and disposal, during which flammable refrigerant can possibly be released to the surrounding space.

- Prior to work taking place, the area around the equipment is to be surveyed to make sure that there are no flammable hazards or ignition risks.
- NO SMOKING signs shall be displayed.

2.7 Ventilated area

- Ensure that the area is in the open or that it is adequately ventilated before breaking into the system or conducting any hot work. A degree of ventilation shall continue during the period that the work is carried out. The ventilation should safely disperse any released refrigerant and preferably expel it externally into the atmosphere.

2.8 Checks to the refrigeration equipment

- Where electrical components are being changed, they shall be fit for the purpose and to the correct specification. At all times the manufacturer's maintenance and service guidelines shall be followed. If in doubt consult the manufacturer's technical department for assistance. The following checks shall be applied to installations using flammable refrigerants:
 - the charge size is in accordance with the room size within which the refrigerant containing parts are installed;
 - the ventilation machinery and outlets are operating adequately and are not obstructed;
 - if an indirect refrigerating circuit is being used, the secondary circuit shall be checked for the presence of refrigerant; marking to the equipment continues to be visible and legible.
 - markings and signs that are illegible shall be corrected;
 - refrigeration pipe or components are installed in a position where they are unlikely to be exposed to any substance which may corrode refrigerant containing components, unless the components are constructed of materials which are inherently resistant to being corroded or are suitably protected against being so corroded.

2.9 Checks to electrical devices

- Repair and maintenance to electrical components shall include initial safety checks and component inspection procedures. If a fault exists that could compromise safety, then no electrical supply shall be connected to the circuit until it is satisfactorily dealt with. If the fault cannot be corrected immediately but it is necessary to continue operation, an adequate temporary solution shall be used. This shall be reported to the owner of the equipment so all parties are advised. Initial safety checks shall include:

- that capacitors are discharged: this shall be done in a safe manner to avoid possibility of sparking;
- that there no live electrical components and wiring are exposed while charging, recovering or purging the system;
- that there is continuity of earth bonding.

2.10 Repairs to sealed components

- During repairs to sealed components, all electrical supplies shall be disconnected from the equipment being worked upon prior to any removal of sealed covers, etc. If it is absolutely necessary to have an electrical supply to equipment during servicing, then a permanently operating form of leak detection shall be located at the most critical point to warn of a potentially hazardous situation.
- Particular attention shall be paid to the following to ensure that by working on electrical components, the casing is not altered in such a way that the level of protection is affected. This shall include damage to cables, excessive number of connections, terminals not made to original specification, damage to seals, incorrect fitting of glands, etc.
 - Ensure that apparatus is mounted securely.
 - Ensure that seals or sealing materials have not degraded such that they no longer serve the purpose of preventing the ingress of flammable atmospheres. Replacement parts shall be in accordance with the manufacturer's specifications.

NOTE: The use of silicon sealant may inhibit the effectiveness of some types of leak detection equipment. Intrinsically safe components do not have to be isolated prior to working on them.

2.11 Repair to intrinsically safe components

- Do not apply any permanent inductive or capacitance loads to the circuit without ensuring that this will not exceed the permissible voltage and current permitted for the equipment in use. Intrinsically safe components are the only types that can be worked on while live in the presence of a flammable atmosphere. The test apparatus shall be at the correct rating.
- Replace components only with parts specified by the manufacturer. Other parts may result in the ignition of refrigerant in the atmosphere from a leak.

2.12 Cabling

- Check that cabling will not be subject to wear, corrosion, excessive pressure, vibration, sharp edges or any other adverse environmental effects. The check

shall also take into account the effects of aging or continual vibration from sources such as compressors or fans.

2.13 Detection of flammable refrigerants

- Under no circumstances shall potential sources of ignition be used in the searching for or detection of refrigerant leaks. A halide torch (or any other detector using a naked flame) shall not be used.

2.14 Leak detection methods

- The following leak detection methods are deemed acceptable for systems containing flammable refrigerants. Electronic leak detectors shall be used to detect flammable refrigerants, but the sensitivity may not be adequate, or may need re-calibration. (Detection equipment shall be calibrated in a refrigerant-free area.) Ensure that the detector is not a potential source of ignition and is suitable for the refrigerant used. Leak detection equipment shall be set at a percentage of the LFL of the refrigerant and shall be calibrated to the refrigerant employed and the appropriate percentage of gas (25 % maximum) is confirmed. Leak detection fluids are suitable for use with most refrigerants but the use of detergents containing chlorine shall be avoided as the chlorine may react with the refrigerant and corrode the copper pipe-work.
 - If a leak is suspected, all naked flames shall be removed or extinguished.
 - If a leakage of refrigerant is found which requires brazing, all of the refrigerant shall be recovered from the system, or isolated (by means of shut off valves) in a part of the system remote from the leak. Oxygen free nitrogen (OFN) shall then be purged through the system both before and during the brazing process.

2.15 Removal and evacuation

- When breaking into the refrigerant circuit to make repairs or for any other purpose, conventional procedures shall be used. However, it is important that best practice is followed since flammability is a consideration.
- The following procedure shall be adhered to:
 - remove refrigerant;
 - purge the circuit with inert gas;
 - evacuate;
 - purge again with inert gas;
 - open the circuit by cutting or brazing.

- The refrigerant charge shall be recovered into the correct recovery cylinders. The system shall be flushed with OFN to render the unit safe. This process may need to be repeated several times. Compressed air or oxygen shall not be used for this task. Flushing shall be achieved by breaking the vacuum in the system with OFN and continuing to fill until the working pressure is achieved, then venting to atmosphere, and finally pulling down to a vacuum. This process shall be repeated until no refrigerant is within the system. When the final OFN charge is used, the system shall be vented down to atmospheric pressure to enable work to take place. This operation is absolutely vital if brazing operations on the pipe-work are to take place.
- Ensure that the outlet for the vacuum pump is not close to any ignition sources and there is ventilation available.

2.16 Charging procedures

- In addition to conventional charging procedures, the following requirements shall be followed:
 - Ensure that contamination of different refrigerants does not occur when using charging equipment. Hoses or lines shall be as short as possible to minimize the amount of refrigerant contained in them.
 - Cylinders shall be kept upright.
 - Ensure that the refrigeration system is earthed prior to charging the system with refrigerant.
 - Label the system when charging is complete (if not already).
 - Extreme care shall be taken not to overfill the refrigeration system.
 - Prior to recharging the system it shall be pressure tested with OFN. The system shall be leak tested on completion of charging but prior to commissioning. A follow up leak test shall be carried out prior to leaving the site.

2.17 Decommissioning

Before carrying out this procedure, it is essential that the technician is completely familiar with the equipment and all its detail. It is recommended good practice that all refrigerants are recovered safely. Prior to the task being carried out, an oil and refrigerant sample shall be taken.

In case analysis is required prior to re-use of reclaimed refrigerant. It is essential that electrical power is available before the task is commenced.

- Become familiar with the equipment and its operation.
- Isolate system electrically.

- Before attempting the procedure ensure that:
 - mechanical handling equipment is available, if required, for handling refrigerant cylinders;
 - all personal protective equipment is available and being used correctly;
 - the recovery process is supervised at all times by a competent person;
 - recovery equipment and cylinders conform to the appropriate standards.
- Pump down refrigerant system, if possible.
- If a vacuum is not possible, make a manifold so that refrigerant can be removed from various parts of the system.
- Make sure that cylinder is situated on the scales before recovery takes place.
- Start the recovery machine and operate in accordance with manufacturer's instructions.
- Do not overfill cylinders. (No more than 80 % volume liquid charge).
- Do not exceed the maximum working pressure of the cylinder, even temporarily.
- When the cylinders have been filled correctly and the process completed, make sure that the cylinders and the equipment are removed from site promptly and all isolation valves on the equipment are closed off.
- Recovered refrigerant shall not be charged into another refrigeration system unless it has been cleaned and checked.

2.18 Labelling

- Equipment shall be labelled stating that it has been decommissioned and emptied of
- refrigerant. The label shall be dated and signed. Ensure that there are labels on the equipment stating the equipment contains flammable refrigerant.

2.19 Recovery

- When removing refrigerant from a system, either for servicing or decommissioning, it is recommended good practice that all refrigerants are removed safely.
- When transferring refrigerant into cylinders, ensure that only appropriate refrigerant recovery cylinders are employed. Ensure that the correct numbers of cylinders for holding the total system charge are available. All cylinders to be used are designated for the recovered refrigerant and labelled for that refrigerant (i.e. special cylinders for the recovery of refrigerant). Cylinders shall be complete with pressure relief valve and associated shut-off valves in good working order.

-
- Empty recovery cylinders are evacuated and, if possible, cooled before recovery occurs.
 - The recovery equipment shall be in good working order with a set of instructions concerning the equipment that is at hand and shall be suitable for the recovery of flammable refrigerants. In addition, a set of calibrated weighing scales shall be available and in good working order.
 - Hoses shall be complete with leak-free disconnect couplings and in good condition. Before using the recovery machine, check that it is in satisfactory working order, has been properly maintained and that any associated electrical components are sealed to prevent ignition in the event of a refrigerant release. Consult manufacturer if in doubt.
 - The recovered refrigerant shall be returned to the refrigerant supplier in the correct recovery cylinder, and the relevant Waste Transfer Note arranged. Do not mix refrigerants in recovery units and especially not in cylinders.
 - If compressors or compressor oils are to be removed, ensure that they have been evacuated to an acceptable level to make certain that flammable refrigerant does not remain within the lubricant. The evacuation process shall be carried out prior to returning the compressor to the suppliers. Only electric heating to the compressor body shall be employed to accelerate this process. When oil is drained from a system, it shall be carried out safely.

Model Reference

Contents

1.	Model Reference.....	2
2	External Appearance.....	3

1. Model Reference

Refer to the following table to determine the specific indoor and outdoor unit model number of your purchased equipment.

Indoor Unit Model		Master Indoor Unit Model	Product code	Outdoor Unit Model	Master Outdoor Unit Model	Product code	Capacity (Btu/h)	Power Supply
AHU	MVB-24HWFN1-M	FM24HIAHUU230X6	22023111000231	MOD31-24HFN1-MT0W	DM24HOS23230E2	22022016005121	24k	1Φ, 208-230V~, 60Hz
				MOD30U-36HFN1-M	DM36HOS18230E5	22022516000402	36k	
				MOE30U-48HFN1-M	DM48HOS18230E5 DM48HOS25230E3	22022516000702	48k	

2. External Appearance

2.1 Indoor Unit



2.2 Outdoor Unit

Single Fan Outdoor Unit



Double Fan Outdoor Unit



Indoor Unit-Air Handler

Contents

1.	Feature.....	2
2.	Dimensional Drawings	3
3.	Part names	4
4.	Service Place.....	4
5.	Accessories	4
6	Static Pressure Selection	5
7	Fan Performance.....	6
8.	Capacity Tables	12
9.	Noise Criterion Curves.....	28
10.	Electrical Characteristics.....	30
11.	Electrical Wiring Diagrams.....	30

1. Feature

1.1 Full Multi-position installation

- This AHU is capable of upflow, downflow, horizontal left, or horizontal right configurations.



1.2 Auto Airflow Volume Match

- Auto AFV Match technology provides most comfortable body sense and lower noise. It ensures the airflow volume can be exactly aligned with demands of ducting. Automatic adjustment beats manual calculation as always.

1.3 Installation Convenience

- It simplifies the airflow volume adjustment process and saves lots of installation efforts. The traditional adjustment method needs the installers to manually set the motor speed, according to the installation instruction and ducting design. It takes lots of time if this thing doesn't go well and decreases the marginal profits.

2. Dimensional Drawings

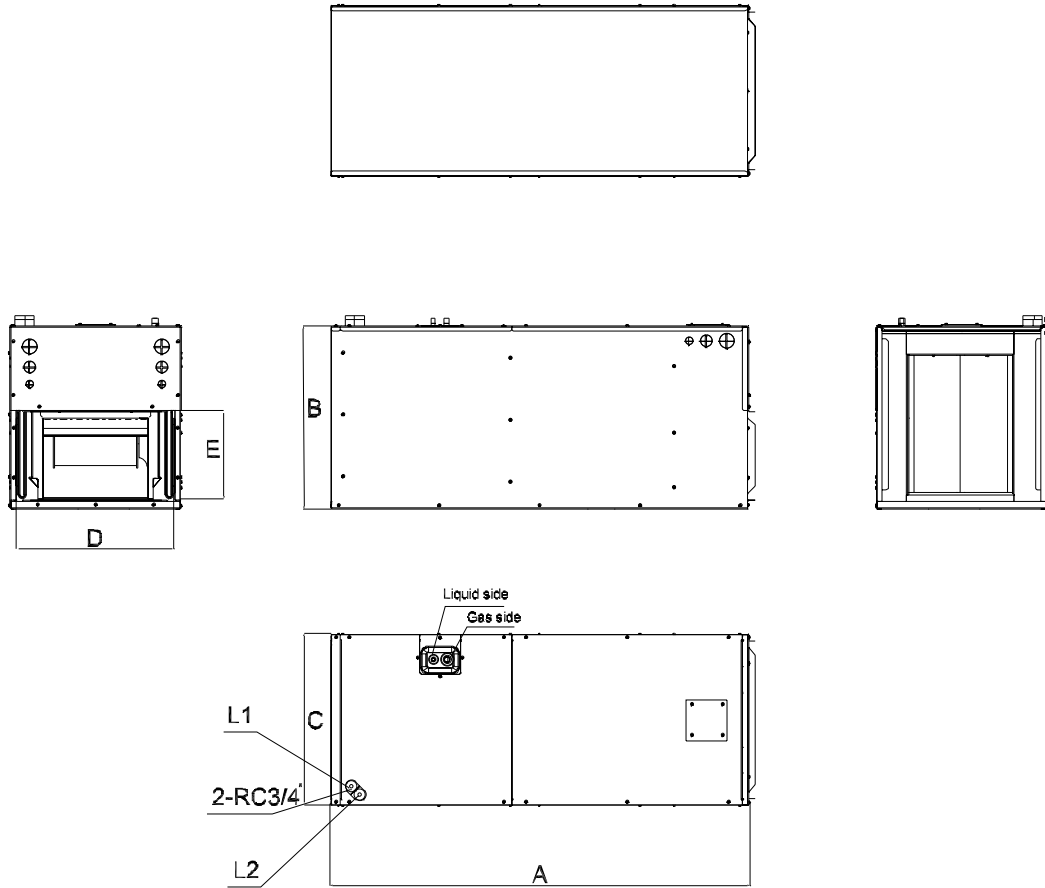

Model	Unit	Dimensions(mm)					Drain hole	
		A	B	C	D	E	L1	L2
24K~48K	mm	1224	533	498	461	261	Primary drain(for upflow)	Primary drain(for horizon)
	inch	48.2	21	19.6	18.2	10.3		

3. Part names

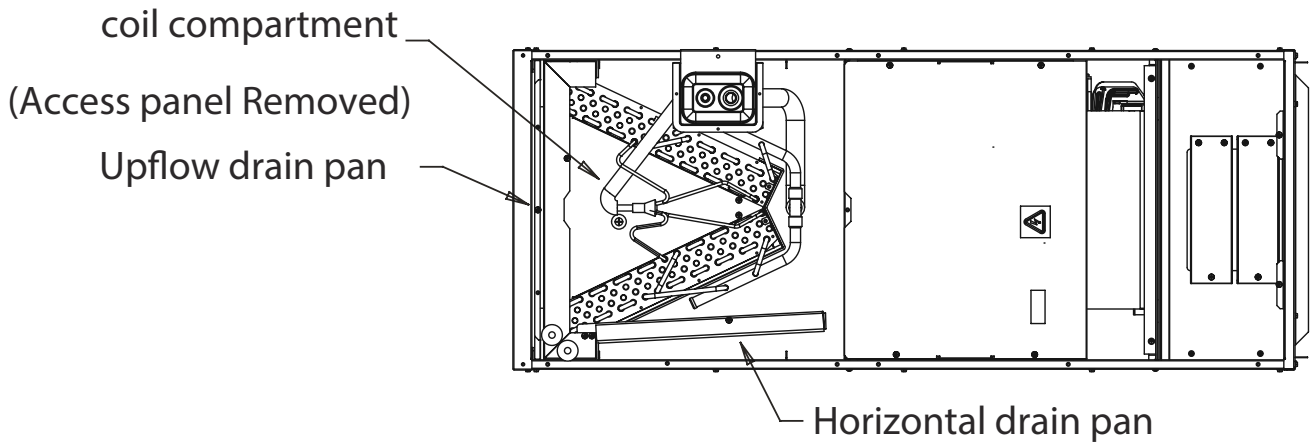

4. Service Place

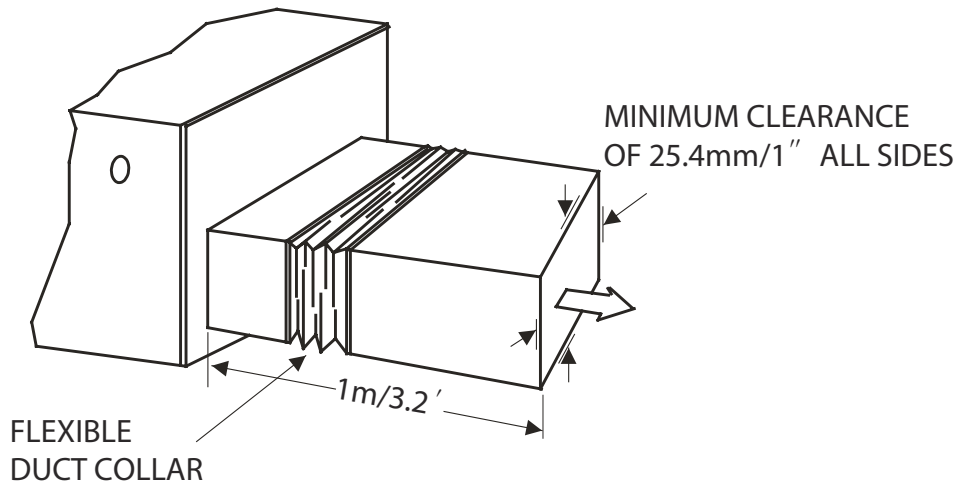

5. Accessories

The air conditioning system comes with the following accessories. Use all of the installation parts and accessories to install the air conditioner. Improper installation may result in water leakage, electrical shock and fire, or equipment failure.

Name	Shape	Quantity
Owner's manual&Installation manual		1

6. Static Pressure Selection(For RG57 Remote Controller)

- The indoor unit should be operated within 10 minutes after recharging. The unit should be powered on and turned off.
- During the first 30 seconds after power on, press and hold the three keys of MODE, FAN and TIMER ON or the two keys of MODE and TIMER ON for 5 seconds, the remote controller will become the function modification remote controller, and F1 will be displayed.

Step 1: Press "△" or "▽" to select the E9.

Step 2: Press "MODE" to set the airflow rate in the range of 1~4.

"1"~"4": Airflow increase progressively

Step 3: Press "MODE" to confirm, then Press "TIMER ON" to finish the airflow setting.

Step 4: Remove the remote controller battery, and then assemble the battery after the remote controller screen is not displayed. The remote controller exits the modification mode. After power off, power on again, the machine will keep the setting value.

NOTE:

1. This function is only suitable for debugging the machine with the RG57 remote controller. Changing the commissioning only allows professional installers to operate.
2. During the static pressure test, it is necessary to assemble the upper cover to the machine, otherwise there may be deviations in the calculated data.
3. The remote controller is only allowed for static pressure debugging and static pressure test functions.

7. Fan Performance

24K

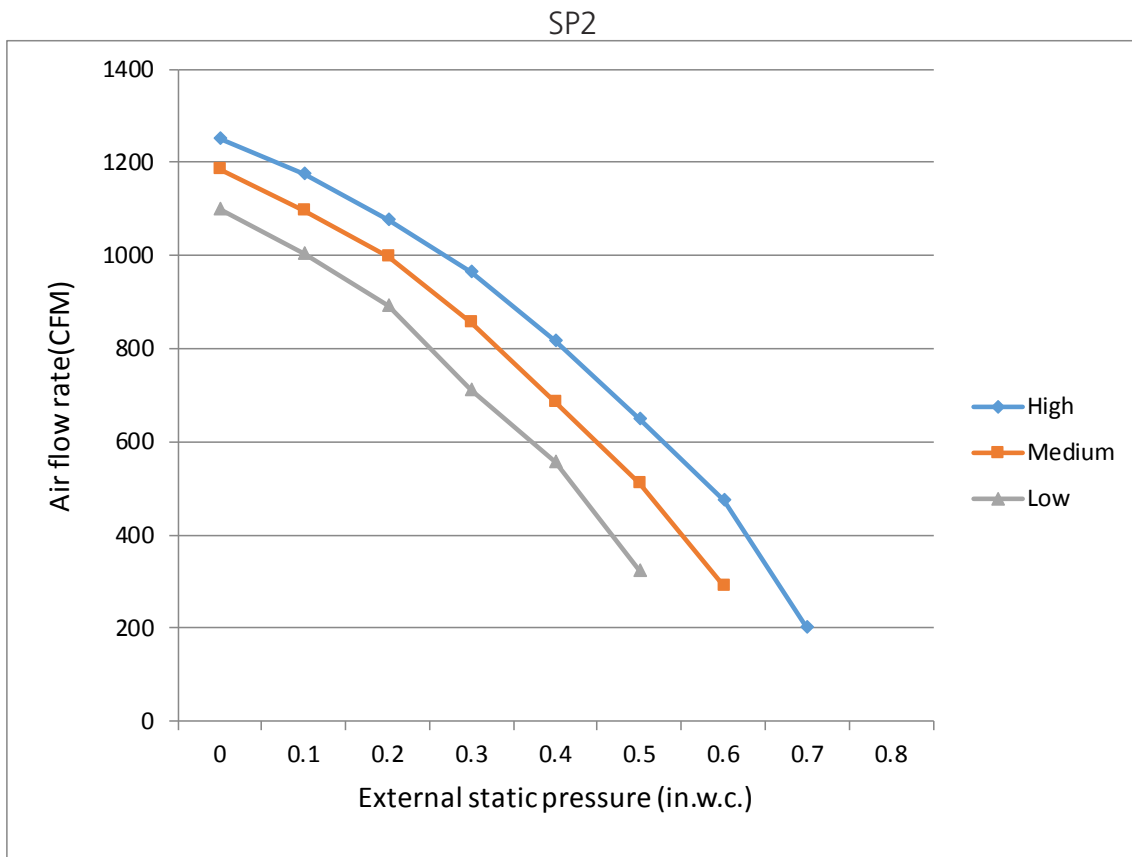
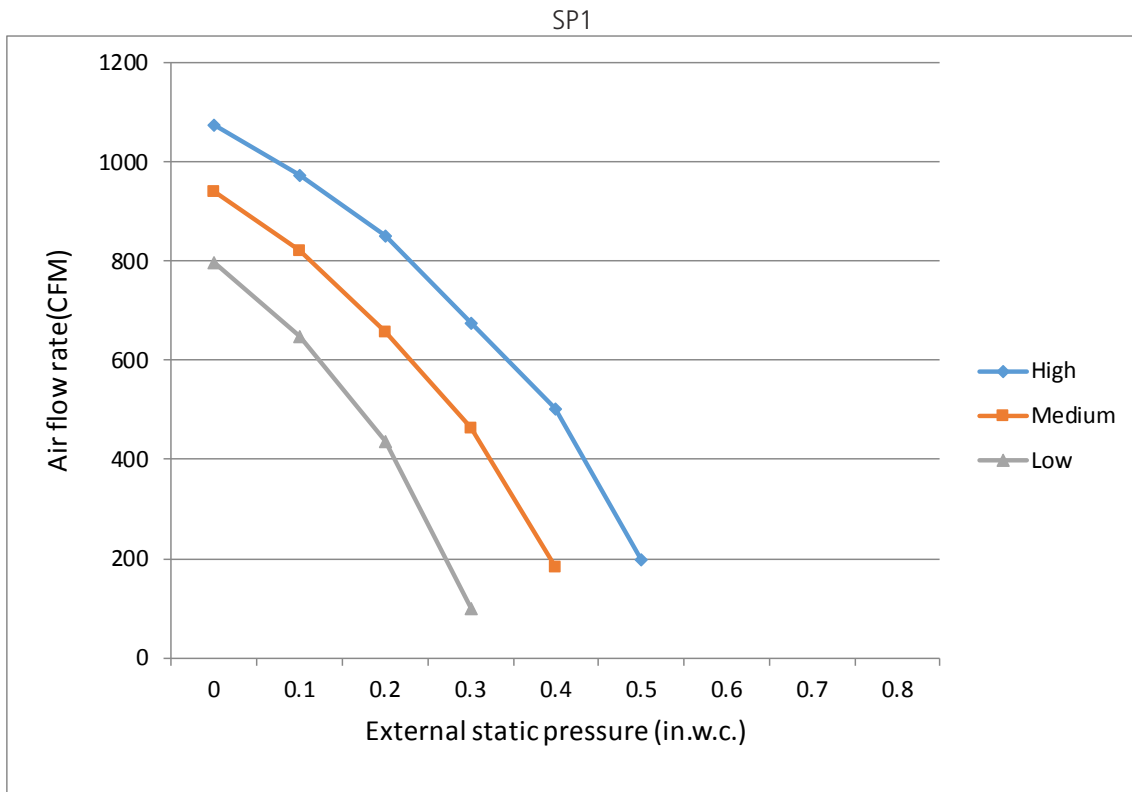

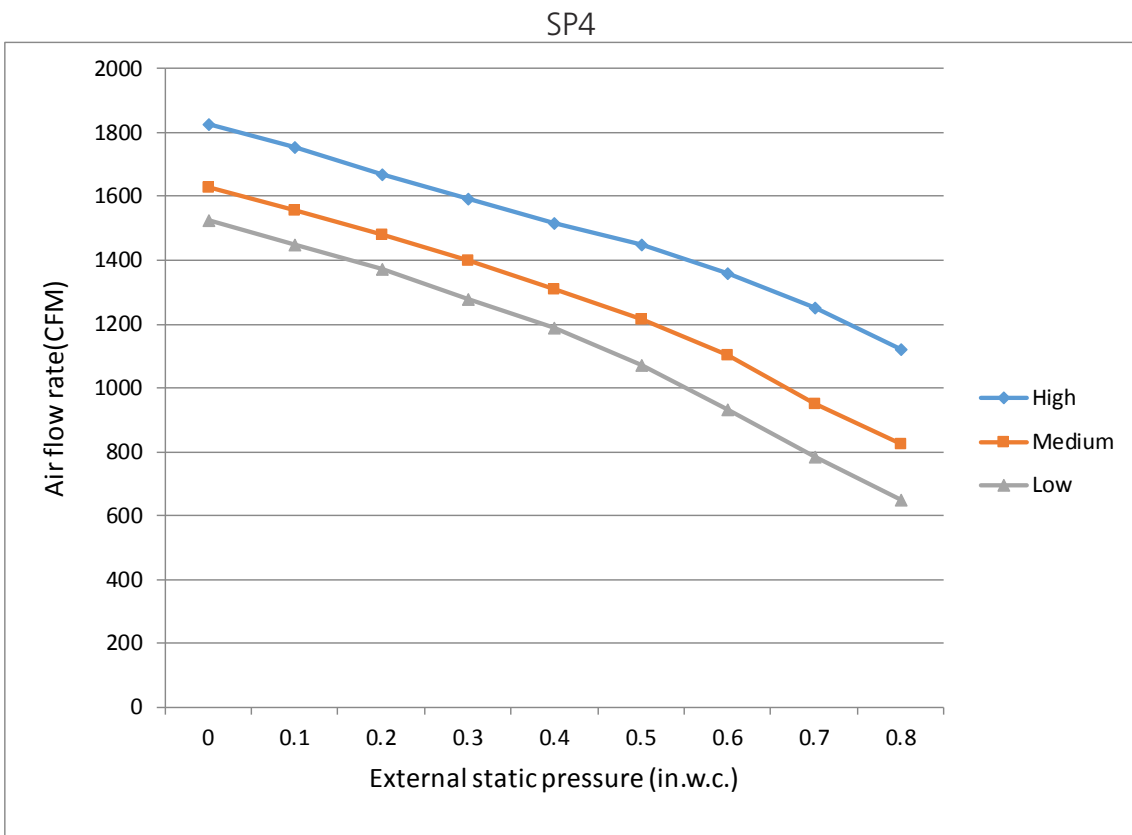
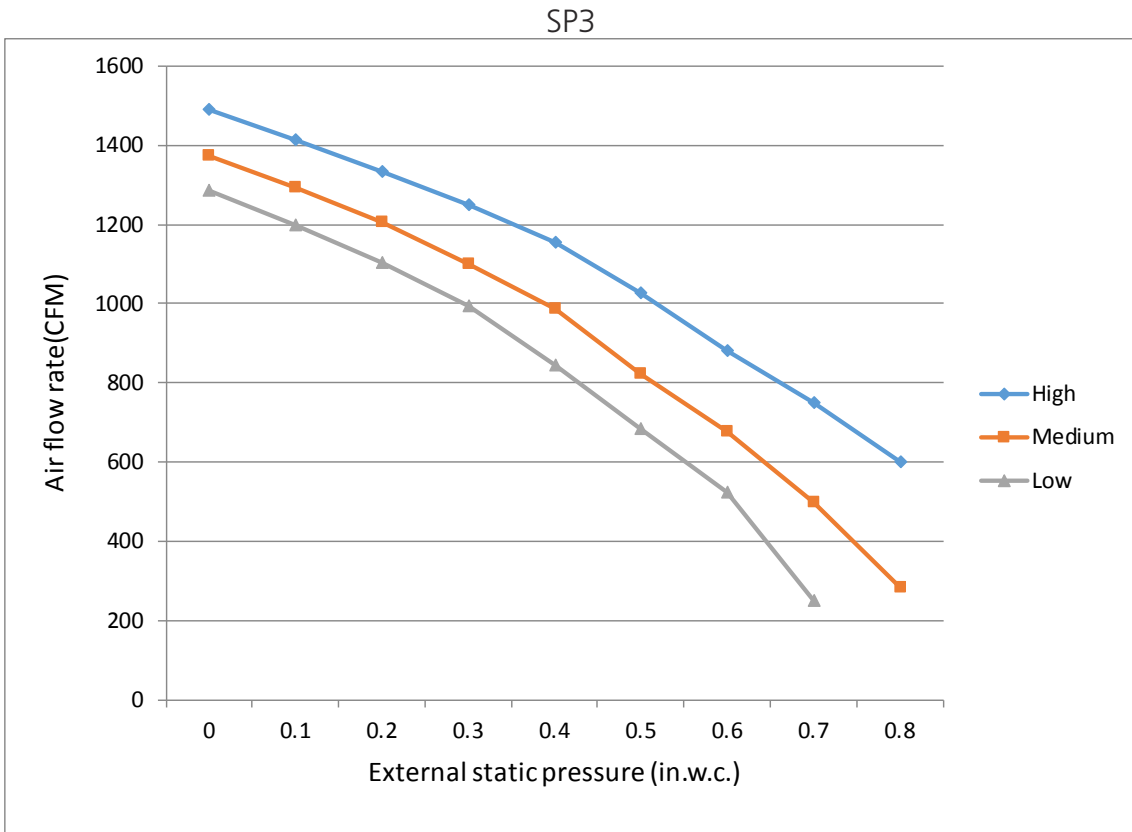

Note:

1. Fan flow rate tests in condition of dry coil without filter or electric heat.
2. The factory setting is SP1.

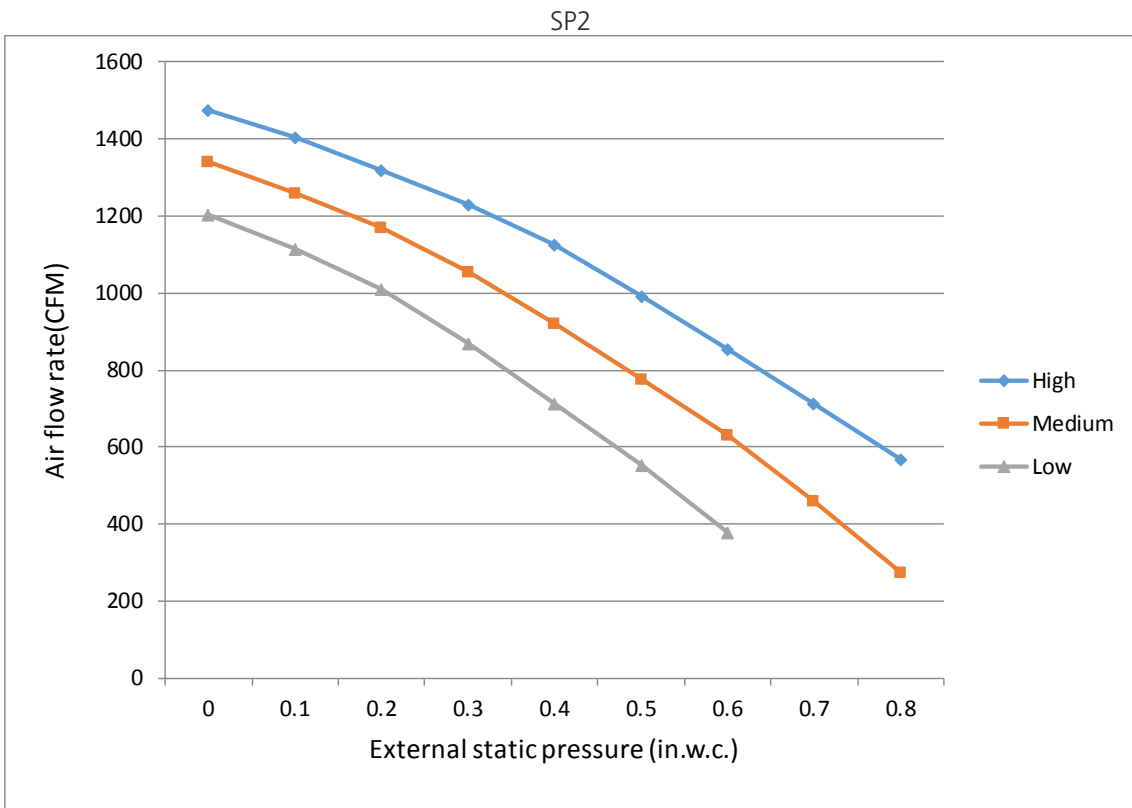
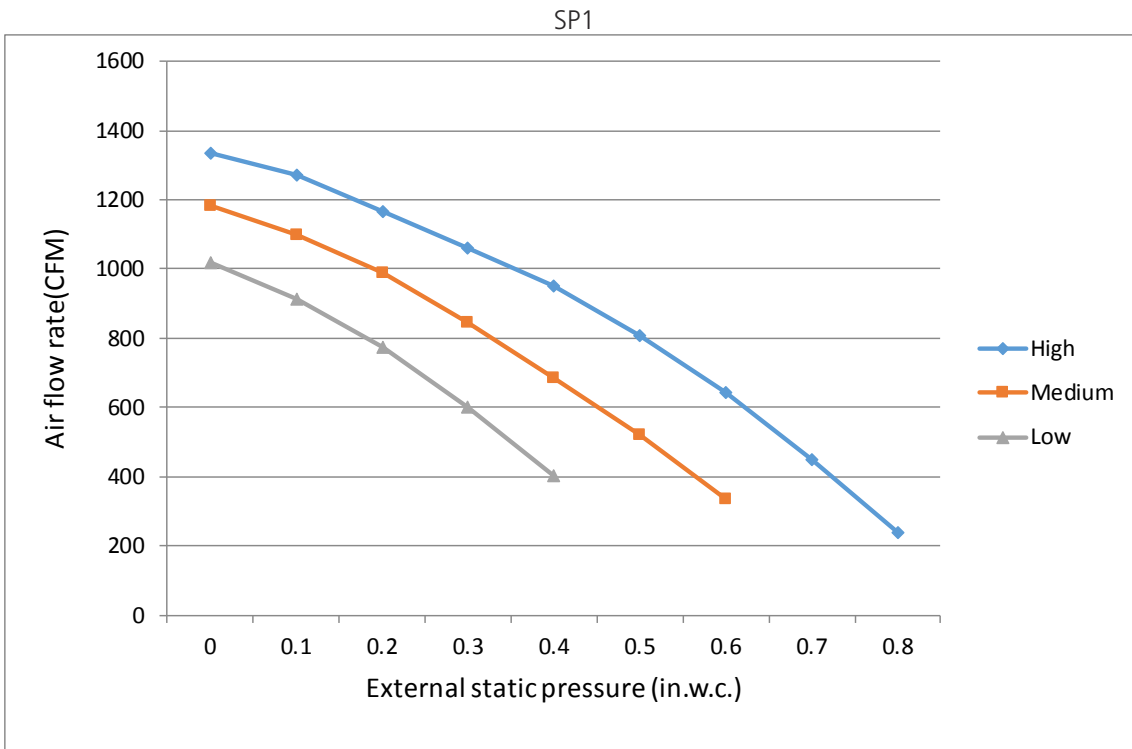

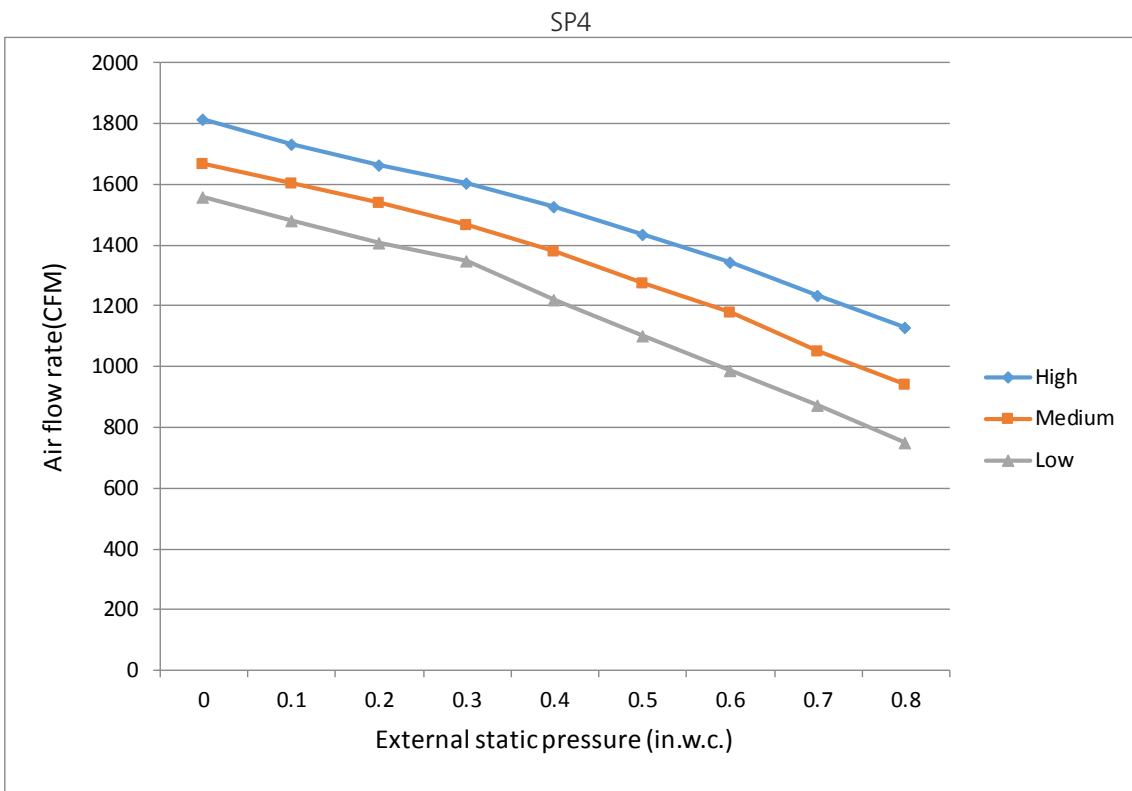
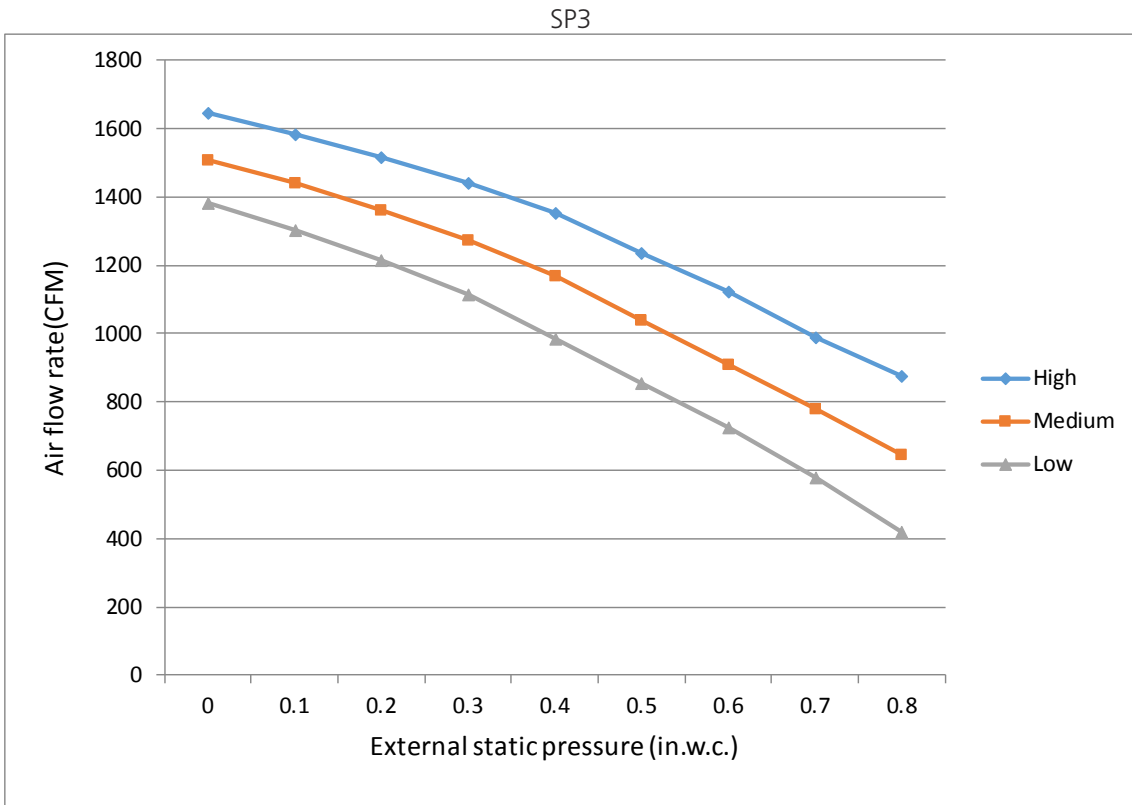

Note:

1. Fan flow rate tests in condition of dry coil without filter or electric heat.
2. The factory setting is SP1.

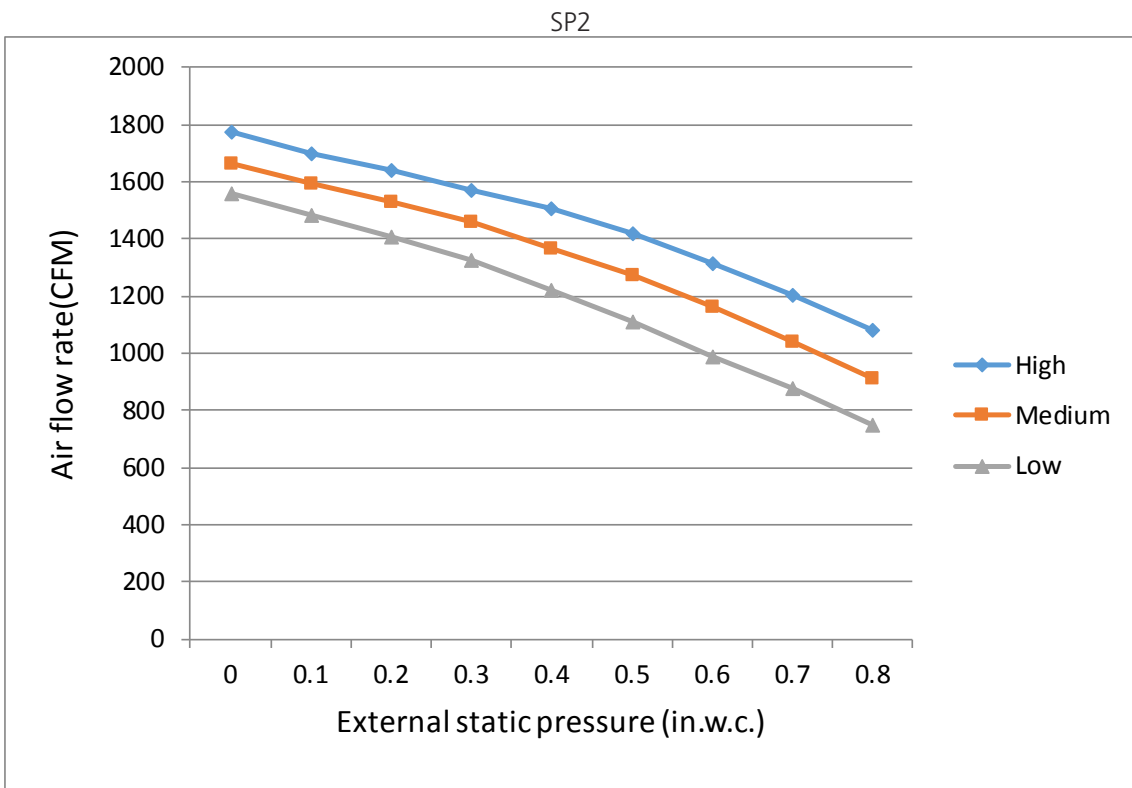
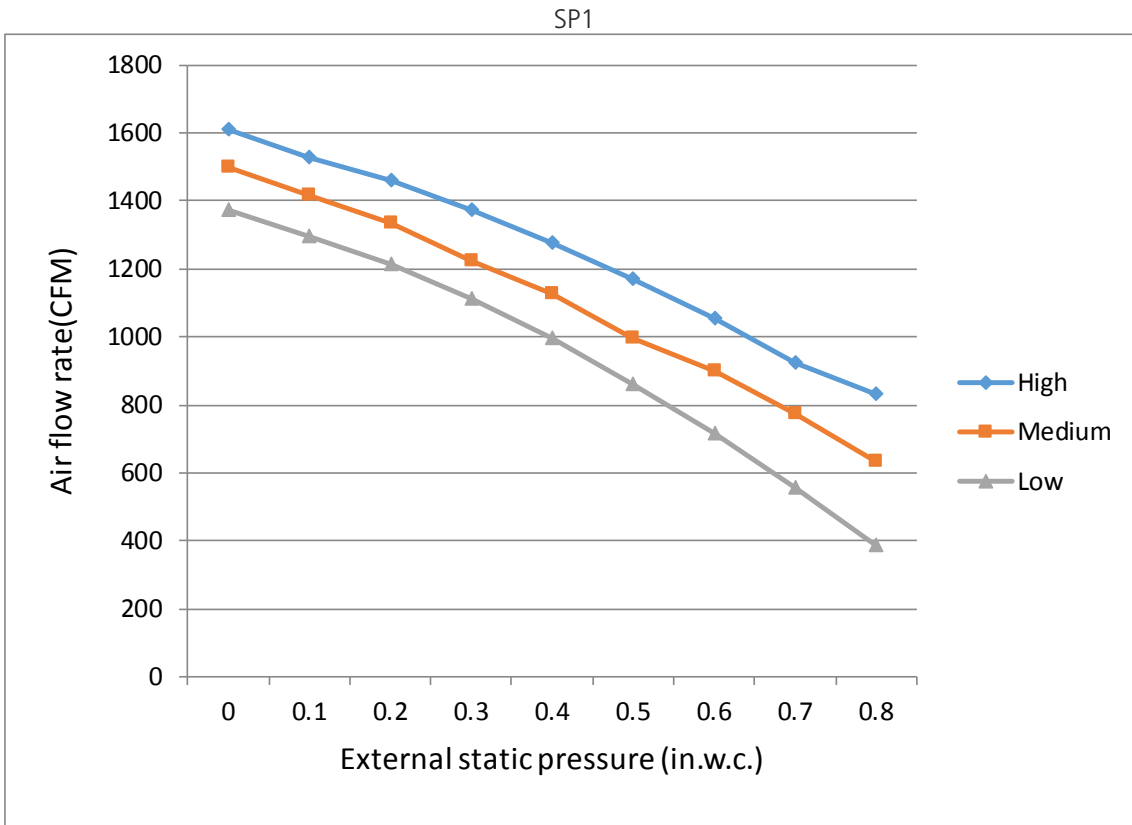

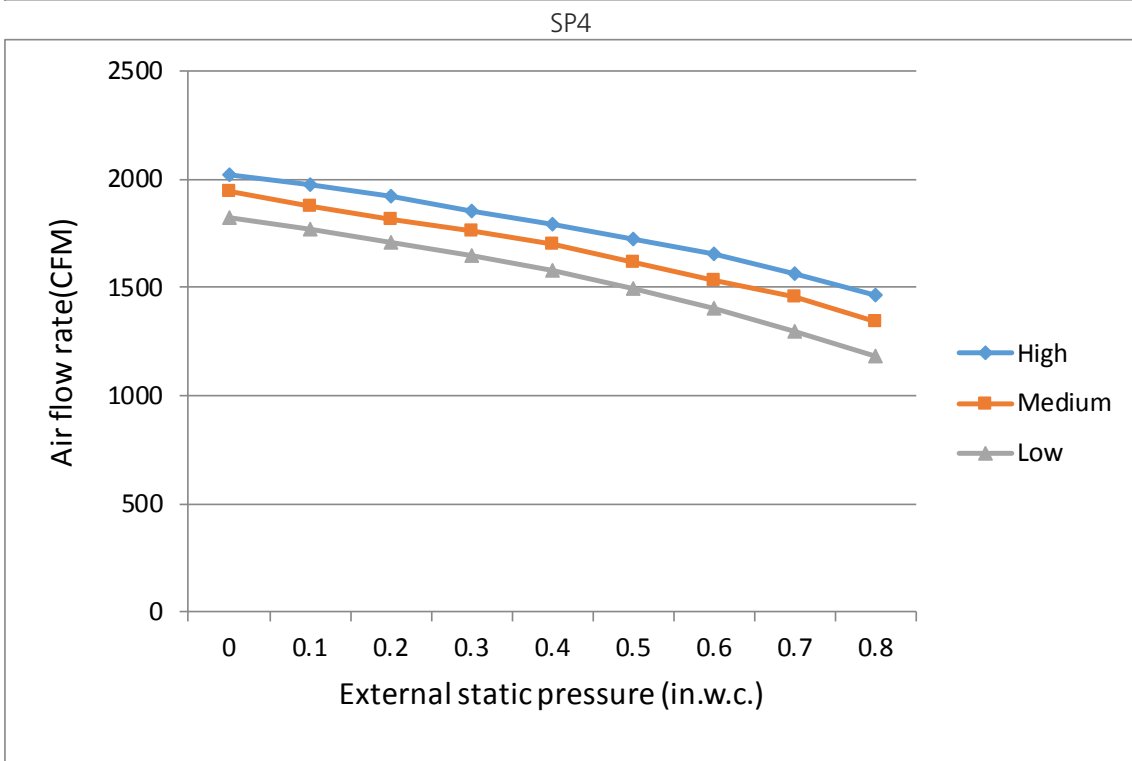
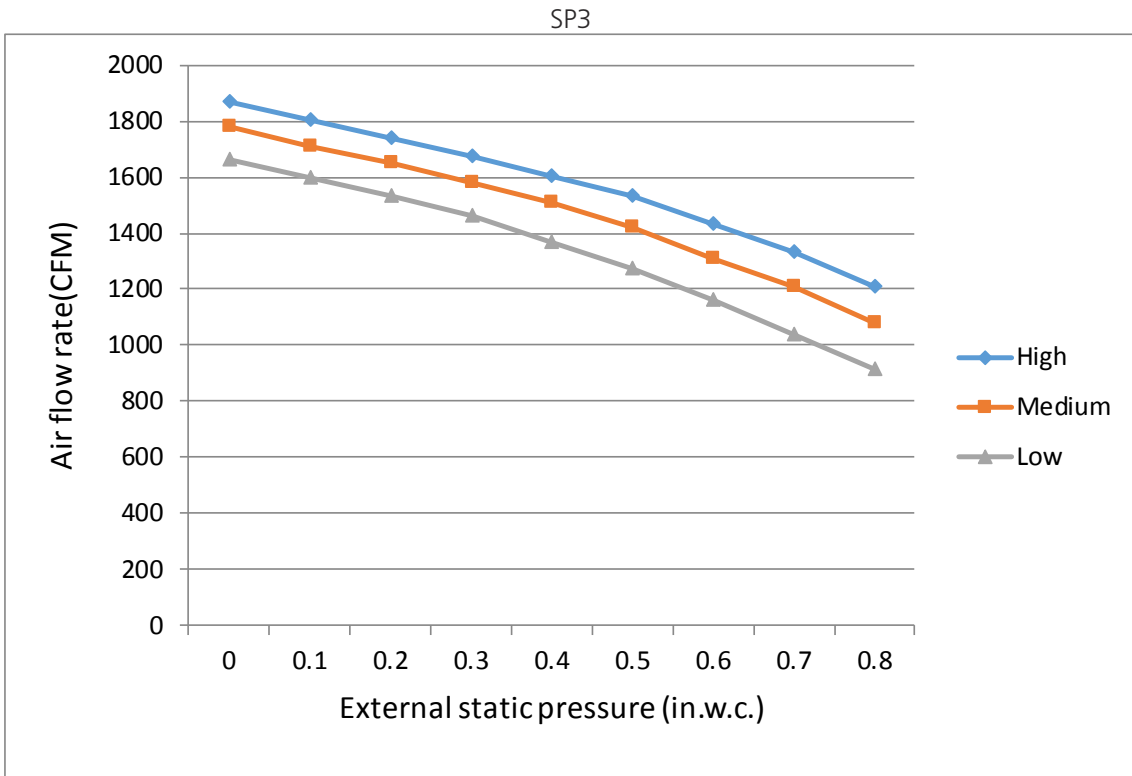

Note:

1. Fan flow rate tests in condition of dry coil without filter or electric heat.
2. The factory setting is SP1.

8. Capacity Tables

8.1 Cooling

		MVB-24HWFN1-M+MOD31-24HFN1-MTOW																
INDOOR AIR FLOW (CFM)	OUTDOOR DB(°F)	ID WB (°F)	60.8				64.4				66.2				71.6			
		ID DB (°F)	73.4	77.0	80.6	84.2	73.4	77.0	80.6	84.2	73.4	77.0	80.6	84.2	73.4	77.0	80.6	84.2
589	5	TC	6.77	6.79	6.85	6.91	7.12	7.24	7.30	7.36	7.30	7.30	7.30	7.30	7.74	7.74	7.74	7.74
		S/T	0.73	0.83	0.93	0.97	0.58	0.67	0.76	0.86	0.50	0.60	0.69	0.78	0.34	0.42	0.51	0.60
		PI	1.17	1.16	1.16	1.17	1.17	1.17	1.17	1.17	1.17	1.17	1.17	1.17	1.17	1.16	1.16	1.16
	14	TC	6.73	6.75	6.81	6.87	7.08	7.20	7.26	7.32	7.26	7.26	7.26	7.26	7.72	7.72	7.72	7.72
		S/T	0.74	0.83	0.93	0.97	0.58	0.68	0.77	0.86	0.50	0.60	0.69	0.79	0.34	0.43	0.51	0.60
		PI	1.16	1.16	1.16	1.16	1.16	1.16	1.16	1.16	1.16	1.16	1.16	1.16	1.16	1.16	1.16	1.16
	23	TC	6.69	6.71	6.77	6.83	7.06	7.18	7.24	7.29	7.24	7.24	7.24	7.24	7.70	7.70	7.70	7.70
		S/T	0.74	0.84	0.94	0.98	0.59	0.68	0.77	0.87	0.51	0.60	0.69	0.79	0.34	0.43	0.52	0.60
		PI	1.16	1.16	1.16	1.16	1.16	1.16	1.16	1.16	1.16	1.16	1.16	1.16	1.16	1.16	1.16	1.16
	32	TC	6.66	6.68	6.74	6.79	7.03	7.15	7.21	7.27	7.22	7.22	7.22	7.22	7.69	7.69	7.69	7.69
		S/T	0.74	0.84	0.94	0.98	0.59	0.68	0.77	0.87	0.51	0.61	0.70	0.79	0.34	0.43	0.52	0.61
		PI	1.17	1.16	1.16	1.16	1.17	1.17	1.17	1.17	1.17	1.17	1.17	1.17	1.17	1.17	1.17	1.17
	41	TC	6.63	6.64	6.70	6.76	7.00	7.12	7.18	7.24	7.19	7.19	7.19	7.19	7.69	7.69	7.69	7.69
		S/T	0.75	0.85	0.95	0.99	0.59	0.69	0.78	0.88	0.51	0.61	0.70	0.80	0.34	0.43	0.52	0.61
		PI	1.18	1.17	1.17	1.18	1.18	1.18	1.18	1.18	1.18	1.18	1.18	1.18	1.18	1.18	1.18	1.18
	50	TC	6.59	6.60	6.66	6.72	6.97	7.09	7.15	7.21	7.16	7.16	7.16	7.16	7.67	7.67	7.67	7.67
		S/T	0.75	0.85	0.95	0.99	0.59	0.69	0.78	0.88	0.51	0.61	0.70	0.80	0.35	0.44	0.52	0.61
		PI	1.20	1.19	1.19	1.20	1.19	1.19	1.19	1.19	1.20	1.20	1.20	1.20	1.19	1.19	1.19	1.19
	59	TC	6.53	6.55	6.61	6.66	6.92	7.04	7.10	7.16	7.12	7.12	7.12	7.12	7.63	7.63	7.63	7.63
		S/T	0.76	0.86	0.96	1.00	0.60	0.69	0.79	0.89	0.52	0.62	0.71	0.81	0.35	0.44	0.53	0.62
		PI	1.22	1.22	1.22	1.22	1.22	1.22	1.22	1.22	1.22	1.22	1.22	1.22	1.22	1.22	1.22	1.22
	68	TC	6.46	6.47	6.53	6.59	6.85	6.85	6.85	6.91	7.05	7.05	7.05	7.05	7.57	7.57	7.57	7.57
		S/T	0.76	0.86	0.96	1.00	0.60	0.70	0.79	0.89	0.52	0.62	0.71	0.81	0.35	0.44	0.53	0.62
		PI	1.27	1.26	1.26	1.27	1.26	1.26	1.26	1.26	1.26	1.26	1.26	1.26	1.25	1.25	1.25	1.25
	77	TC	6.16	6.16	6.22	6.27	6.53	6.53	6.53	6.59	6.73	6.73	6.73	6.73	7.25	7.25	7.25	7.25
		S/T	0.77	0.88	0.99	1.00	0.60	0.71	0.81	0.91	0.53	0.63	0.73	0.83	0.35	0.44	0.53	0.62
		PI	1.40	1.40	1.40	1.40	1.40	1.40	1.40	1.40	1.40	1.40	1.40	1.40	1.40	1.40	1.40	1.40
	86	TC	5.87	5.93	5.99	6.04	6.24	6.24	6.24	6.30	6.45	6.45	6.45	6.45	6.93	6.93	6.93	6.93
		S/T	0.79	0.90	1.00	1.00	0.61	0.72	0.83	0.93	0.53	0.63	0.74	0.84	0.34	0.44	0.54	0.63
		PI	1.53	1.53	1.53	1.53	1.54	1.54	1.54	1.54	1.54	1.54	1.54	1.54	1.54	1.54	1.54	1.54
	95	TC	5.58	5.64	5.70	5.76	5.93	5.93	5.93	5.99	6.13	6.13	6.22	6.13	6.59	6.59	6.59	6.59
		S/T	0.80	0.92	1.00	1.00	0.62	0.73	0.85	0.95	0.53	0.64	0.75	0.86	0.34	0.44	0.54	0.65
		PI	1.67	1.67	1.67	1.67	1.67	1.67	1.67	1.67	1.68	1.68	1.68	1.68	1.69	1.69	1.69	1.69
	104	TC	5.19	5.24	5.30	5.36	5.52	5.52	5.54	5.60	5.70	5.70	5.75	5.73	6.16	6.16	6.16	6.16
		S/T	0.83	0.96	1.00	1.00	0.63	0.76	0.88	1.00	0.54	0.66	0.78	0.90	0.33	0.45	0.56	0.67
		PI	1.84	1.84	1.84	1.84	1.85	1.85	1.85	1.85	1.85	1.85	1.85	1.85	1.87	1.87	1.87	1.87
	114.8	TC	4.80	4.86	4.91	4.97	5.11	5.11	5.17	5.23	5.28	5.28	5.28	5.34	5.74	5.74	5.74	5.74
		S/T	0.85	0.98	1.00	1.00	0.64	0.77	0.90	1.00	0.55	0.67	0.80	0.92	0.33	0.45	0.56	0.68
		PI	2.05	2.05	2.05	2.05	2.06	2.06	2.06	2.06	2.06	2.06	2.06	2.06	2.08	2.08	2.08	2.08
	122	TC	4.52	4.57	4.63	4.69	4.83	4.83	4.89	4.94	4.97	4.97	4.97	5.03	5.40	5.40	5.40	5.40
		S/T	0.87	1.00	1.00	1.00	0.65	0.79	0.92	1.00	0.56	0.69	0.82	0.95	0.33	0.45	0.57	0.70
		PI	2.22	2.22	2.22	2.22	2.23	2.23	2.23	2.23	2.24	2.24	2.24	2.24	2.25	2.25	2.25	2.25

765	5	TC	6.91	6.97	7.03	7.09	7.24	7.24	7.30	7.36	7.45	7.45	7.45	7.54	7.89	7.89	7.89	7.89
		S/T	0.80	0.93	0.98	1.00	0.62	0.73	0.85	0.97	0.52	0.65	0.76	0.87	0.32	0.43	0.54	0.65
		PI	1.19	1.19	1.19	1.19	1.20	1.20	1.20	1.20	1.19	1.19	1.19	1.19	1.19	1.19	1.19	1.19
	14	TC	6.87	6.93	6.99	7.05	7.20	7.20	7.26	7.32	7.41	7.41	7.41	7.50	7.87	7.87	7.87	7.87
		S/T	0.81	0.93	0.99	1.00	0.62	0.74	0.85	0.97	0.52	0.65	0.77	0.87	0.32	0.44	0.54	0.65
		PI	1.19	1.19	1.19	1.19	1.19	1.19	1.19	1.19	1.19	1.19	1.19	1.19	1.19	1.19	1.19	1.19
	23	TC	6.83	6.89	6.95	7.01	7.18	7.18	7.24	7.29	7.39	7.39	7.39	7.48	7.85	7.85	7.85	7.85
		S/T	0.81	0.94	0.99	1.00	0.62	0.74	0.86	0.98	0.53	0.65	0.77	0.88	0.32	0.44	0.55	0.65
		PI	1.19	1.19	1.19	1.19	1.19	1.19	1.19	1.19	1.19	1.19	1.19	1.19	1.19	1.19	1.19	1.19
	32	TC	6.80	6.86	6.92	6.97	7.15	7.15	7.21	7.27	7.37	7.37	7.37	7.45	7.84	7.84	7.84	7.84
		S/T	0.81	0.94	1.00	1.00	0.63	0.74	0.86	0.98	0.53	0.66	0.77	0.88	0.32	0.44	0.55	0.66
		PI	1.19	1.19	1.19	1.19	1.20	1.20	1.20	1.20	1.19	1.19	1.19	1.19	1.20	1.20	1.20	1.20
	41	TC	6.76	6.82	6.88	6.94	7.12	7.12	7.18	7.24	7.34	7.34	7.34	7.43	7.83	7.83	7.83	7.83
		S/T	0.82	0.95	1.00	1.00	0.63	0.75	0.87	0.99	0.53	0.66	0.78	0.89	0.33	0.44	0.55	0.66
		PI	1.20	1.20	1.20	1.20	1.21	1.21	1.21	1.21	1.20	1.20	1.20	1.20	1.21	1.21	1.21	1.21
	50	TC	6.72	6.78	6.84	6.90	7.09	7.09	7.15	7.21	7.31	7.31	7.31	7.40	7.81	7.81	7.81	7.81
		S/T	0.82	0.95	1.00	1.00	0.63	0.75	0.87	0.99	0.53	0.66	0.78	0.89	0.33	0.45	0.55	0.66
		PI	1.22	1.22	1.22	1.22	1.22	1.22	1.22	1.22	1.22	1.22	1.22	1.22	1.22	1.22	1.22	1.22
59	TC	6.67	6.73	6.78	6.84	7.04	7.04	7.10	7.16	7.27	7.27	7.27	7.35	7.78	7.78	7.78	7.78	
	S/T	0.83	0.96	1.00	1.00	0.64	0.76	0.88	1.00	0.54	0.67	0.79	0.90	0.33	0.45	0.56	0.67	
	PI	1.25	1.25	1.25	1.25	1.25	1.25	1.25	1.25	1.24	1.24	1.24	1.24	1.25	1.25	1.25	1.25	1.25
68	TC	6.59	6.65	6.71	6.76	6.97	6.97	7.02	7.08	7.20	7.20	7.20	7.28	7.71	7.71	7.71	7.71	
	S/T	0.83	0.96	1.00	1.00	0.64	0.76	0.88	1.00	0.54	0.67	0.79	0.90	0.33	0.45	0.56	0.67	
	PI	1.30	1.30	1.30	1.30	1.30	1.30	1.30	1.30	1.29	1.29	1.29	1.29	1.29	1.29	1.29	1.29	1.29
77	TC	6.28	6.33	6.39	6.45	6.68	6.68	6.74	6.79	6.88	6.88	6.88	6.94	7.40	7.40	7.40	7.40	
	S/T	0.85	0.98	1.00	1.00	0.64	0.77	0.90	1.00	0.55	0.68	0.80	0.93	0.33	0.45	0.57	0.69	
	PI	1.43	1.43	1.43	1.43	1.43	1.43	1.43	1.43	1.43	1.43	1.43	1.43	1.43	1.43	1.43	1.43	1.43
86	TC	5.99	6.04	6.10	6.16	6.36	6.36	6.42	6.48	6.56	6.56	6.56	6.62	7.05	7.05	7.05	7.05	
	S/T	0.87	1.00	1.00	1.00	0.65	0.79	0.92	1.00	0.55	0.69	0.82	0.95	0.33	0.45	0.58	0.70	
	PI	1.57	1.57	1.57	1.57	1.57	1.57	1.57	1.57	1.57	1.57	1.57	1.57	1.58	1.58	1.58	1.58	1.58
95	TC	5.67	5.73	5.79	5.84	6.04	6.04	6.10	6.16	6.25	6.25	6.33	6.39	6.74	6.74	6.74	6.74	
	S/T	0.89	1.00	1.00	1.00	0.66	0.81	0.95	1.00	0.56	0.70	0.84	0.97	0.33	0.46	0.58	0.72	
	PI	1.71	1.71	1.71	1.71	1.72	1.72	1.72	1.72	1.72	1.72	1.72	1.72	1.72	1.72	1.72	1.72	1.72
104	TC	5.36	5.42	5.47	5.53	5.72	5.72	5.78	5.84	5.91	5.91	5.98	6.04	6.37	6.37	6.37	6.37	
	S/T	0.93	1.00	1.00	1.00	0.69	0.85	1.00	1.00	0.57	0.73	0.88	1.00	0.32	0.46	0.60	0.75	
	PI	1.89	1.89	1.89	1.89	1.90	1.90	1.90	1.90	1.90	1.90	1.90	1.90	1.91	1.91	1.91	1.91	1.91
114.8	TC	4.96	5.02	5.08	5.14	5.31	5.31	5.37	5.43	5.48	5.48	5.54	5.60	5.92	5.92	5.92	5.92	
	S/T	0.95	1.00	1.00	1.00	0.70	0.86	1.00	1.00	0.58	0.74	0.90	1.00	0.32	0.47	0.61	0.76	
	PI	2.10	2.10	2.10	2.10	2.11	2.11	2.11	2.11	2.12	2.12	2.12	2.12	2.13	2.13	2.13	2.13	2.13
122	TC	4.65	4.70	4.76	4.82	4.99	5.05	5.11	5.17	5.14	5.14	5.20	5.25	5.57	5.57	5.57	5.57	
	S/T	0.99	1.00	1.00	1.00	0.72	0.89	1.00	1.00	0.59	0.76	0.93	1.00	0.31	0.47	0.63	0.91	
	PI	2.28	2.28	2.28	2.28	2.29	2.29	2.29	2.29	2.29	2.29	2.29	2.29	2.31	2.31	2.31	2.31	2.31
883	5	TC	7.03	7.09	7.15	7.21	7.39	7.39	7.45	7.51	7.57	7.57	7.57	7.66	8.04	8.04	8.04	8.04
		S/T	0.85	0.97	1.00	1.00	0.64	0.77	0.91	0.98	0.54	0.68	0.81	0.94	0.32	0.43	0.56	0.69
		PI	1.22	1.22	1.22	1.22	1.21	1.21	1.21	1.21	1.21	1.21	1.21	1.21	1.21	1.21	1.21	1.21
	14	TC	6.99	7.05	7.11	7.17	7.35	7.35	7.41	7.47	7.53	7.53	7.53	7.62	8.01	8.01	8.01	8.01
		S/T	0.85	0.97	1.00	1.00	0.64	0.78	0.91	0.98	0.54	0.68	0.82	0.94	0.32	0.44	0.56	0.69
		PI	1.21	1.21	1.21	1.21	1.21	1.21	1.21	1.21	1.21	1.21	1.21	1.21	1.21	1.21	1.21	1.21
	23	TC	6.95	7.01	7.07	7.13	7.32	7.32	7.38	7.44	7.50	7.50	7.50	7.59	7.99	7.99	7.99	7.99
		S/T	0.86	0.98	1.00	1.00	0.64	0.78	0.92	0.99	0.55	0.68	0.82	0.95	0.32	0.44	0.57	0.69
		PI	1.21	1.21	1.21	1.21	1.21	1.21	1.21	1.21	1.21	1.21	1.21	1.21	1.21	1.21	1.21	1.21
	32	TC	6.92	6.97	7.03	7.09	7.30	7.30	7.36	7.41	7.48	7.48	7.48	7.57	7.99	7.99	7.99	7.99
		S/T	0.86	0.98	1.00	1.00	0.65	0.78	0.92	0.99	0.55	0.69	0.82	0.95	0.32	0.44	0.57	0.70
		PI	1.22	1.22	1.22	1.22	1.21	1.21	1.21	1.21	1.22	1.22	1.22	1.22	1.22	1.22	1.22	1.22
	41	TC	6.88	6.94	7.00	7.06	7.27	7.27	7.33	7.39	7.46	7.46	7.46	7.55	7.98	7.98	7.98	7.98
		S/T	0.87	0.99	1.00	1.00	0.65	0.79	0.93	1.00	0.55	0.69	0.83	0.96	0.33	0.44	0.57	0.70
		PI	1.23	1.23	1.23	1.23	1.22	1.22	1.22	1.22	1.23	1.23	1.23	1.23	1.22	1.22	1.22	1.22
	50	TC	6.84	6.90	6.96	7.02	7.23	7.23	7.29	7.35	7.43	7.43	7.43	7.52	7.96	7.96	7.96	7.96
		S/T	0.87	0.99	1.00	1.00	0.65	0.79	0.93	1.00	0.55	0.69	0.83	0.96	0.33	0.45	0.57	0.70
		PI	1.25	1.25	1.25	1.25	1.24	1.24	1.24	1.24	1.25	1.25	1.25	1.25	1.24	1.24	1.24	1.24
59	TC	6.78	6.84	6.90	6.96	7.19	7.19	7.24	7.30	7.38	7.38	7.38	7.47	7.93	7.93	7.93	7.93	
	S/T	0.88	1.00	1.00	1.00	0.66	0.80	0.94	1.00	0.56	0.70	0.84	0.97	0.33	0.45	0.58	0.71	
	PI	1.28	1.28	1.28	1.28	1.27	1.27	1.27	1.27	1.27	1.27	1.27	1.27	1.27	1.27	1.27	1.27	1.27
68	TC	6.71	6.76	6.82	6.88	7.11	7.11	7.17	7.23	7.31	7.31	7.31	7.40	7.86	7.86	7.86	7.86	
	S/T	0.88	1.00	1.00	1.00	0.66	0.80	0.94	1.00	0.56	0.70	0.84	0.97	0.33	0.45	0.58	0.71	
	PI	1.33	1.33	1.33	1.33	1.32	1.32	1.32	1.32	1.32	1.32	1.32	1.32	1.31	1.31	1.31	1.31	1.31
77	TC	6.39	6.45	6.51	6.56	6.79	6.79	6.85	6.91	6.99	6.99	6.99	7.05	7.51	7.51	7.51	7.51	
	S/T	0.90	1.00	1.00	1.00	0.67	0.82	0.96	1.00	0.57	0.71	0.85	0.99	0.32	0.46	0.59	0.73	
	PI	1.45	1.45	1.45	1.45	1.45	1.45	1.45	1.45	1.45	1.45	1.45	1.45	1.45	1.45	1.45	1.45	1.45
86	TC	6.10	6.16	6.22	6.28	6.48	6.48	6.53	6.59	6.68	6.68	6.68	6.74	7.20	7.20	7.20	7.20	
	S/T	0.92	1.00	1.00	1.00	0.68	0.84	0.99	1.00	0.57	0.72	0.87	1.00	0.32	0.46	0.60	0.74	
	PI	1.60	1.60	1.60	1.60	1.60	1.60	1.60	1.60	1.60	1.60	1.60	1.60	1.61	1.61	1.61	1.61	1.61
95	TC	5.79	5.84	5.90	5.96	6.16	6.16	6.22	6.28	6.36	6.36	6.45	6.51	6.85	6.85	6.85	6.85	
	S/T	0.95	1.00	1.00	1.00	0.70	0.86	1.00	1.00	0.58	0.74	0.89	1.00	0.32	0.47	0.61	0.76	
	PI	1.75	1.75	1.75	1.75	1.75	1.75	1.75	1.75	1.76	1.76	1.76	1.76	1.77	1.77	1.77	1.77	1.77
104	TC	5.46	5.52	5.58	5.63	5.82	5.85	5.91	5.96	6.01	6.01	6.08	6.14	6.49	6.49	6.49	6.49	
	S/T	0.99	1.00	1.00	1.0													

MVB-24HWFN1-M+MOD01-23HFN1-MTOW or MOD30-24HFN1-MTOW																			
INDOOR AIR FLOW (CFM)	OUTDOOR DB(°F)	ID WB (°F)	60.8				64.4				66.2				71.6				
			ID DB (°F)	73.4	77.0	80.6	84.2	73.4	77.0	80.6	84.2	73.4	77.0	80.6	84.2	73.4	77.0	80.6	84.2
589	5	TC	6.39	6.39	6.45	6.51	6.72	6.85	6.91	6.97	6.88	6.88	6.88	6.88	7.32	7.32	7.32	7.32	
		S/T	0.74	0.85	0.96	0.97	0.59	0.68	0.78	0.88	0.51	0.61	0.70	0.80	0.34	0.42	0.51	0.61	
		PI	1.11	1.11	1.11	1.11	1.11	1.11	1.11	1.11	1.11	1.11	1.11	1.11	1.10	1.10	1.10	1.10	
	14	TC	6.35	6.35	6.41	6.47	6.68	6.81	6.87	6.93	6.84	6.84	6.84	6.84	7.30	7.30	7.30	7.30	
		S/T	0.75	0.85	0.96	0.97	0.59	0.69	0.79	0.88	0.51	0.61	0.71	0.81	0.34	0.43	0.51	0.61	
		PI	1.10	1.11	1.11	1.10	1.10	1.10	1.10	1.10	1.10	1.10	1.10	1.10	1.10	1.10	1.10	1.10	
	23	TC	6.31	6.31	6.37	6.43	6.66	6.78	6.84	6.90	6.82	6.82	6.82	6.82	7.28	7.28	7.28	7.28	
		S/T	0.75	0.86	0.97	0.98	0.59	0.69	0.79	0.89	0.52	0.61	0.71	0.81	0.34	0.43	0.52	0.61	
		PI	1.10	1.11	1.11	1.10	1.10	1.10	1.10	1.10	1.10	1.10	1.10	1.10	1.10	1.10	1.10	1.10	
	32	TC	6.28	6.28	6.34	6.40	6.63	6.76	6.82	6.88	6.80	6.80	6.80	6.80	7.28	7.28	7.28	7.28	
		S/T	0.75	0.86	0.97	0.98	0.60	0.69	0.79	0.89	0.52	0.62	0.72	0.81	0.34	0.43	0.52	0.62	
		PI	1.11	1.11	1.11	1.11	1.11	1.11	1.11	1.11	1.11	1.11	1.11	1.11	1.11	1.11	1.11	1.11	
	41	TC	6.25	6.25	6.31	6.37	6.61	6.73	6.79	6.85	6.77	6.77	6.77	6.77	7.27	7.27	7.27	7.27	
		S/T	0.76	0.87	0.98	0.99	0.60	0.70	0.80	0.90	0.52	0.62	0.72	0.82	0.34	0.43	0.52	0.62	
		PI	1.12	1.12	1.12	1.12	1.11	1.11	1.11	1.11	1.12	1.12	1.12	1.12	1.11	1.11	1.11	1.11	
	50	TC	6.21	6.21	6.27	6.33	6.58	6.70	6.76	6.82	6.75	6.75	6.75	6.75	7.25	7.25	7.25	7.25	
		S/T	0.76	0.87	0.98	0.99	0.60	0.70	0.80	0.90	0.52	0.62	0.72	0.82	0.35	0.44	0.52	0.62	
		PI	1.14	1.14	1.14	1.14	1.13	1.13	1.13	1.13	1.13	1.13	1.13	1.13	1.13	1.13	1.13	1.13	
	59	TC	6.16	6.16	6.22	6.28	6.53	6.66	6.71	6.77	6.71	6.71	6.71	6.71	7.22	7.22	7.22	7.22	
		S/T	0.77	0.88	0.99	1.00	0.61	0.71	0.81	0.91	0.53	0.63	0.73	0.83	0.35	0.44	0.53	0.63	
		PI	1.16	1.17	1.17	1.16	1.16	1.16	1.16	1.16	1.16	1.16	1.16	1.16	1.15	1.15	1.15	1.15	
	68	TC	6.09	6.09	6.15	6.21	6.46	6.47	6.47	6.53	6.64	6.64	6.64	6.64	7.16	7.16	7.16	7.16	
		S/T	0.77	0.88	0.99	1.00	0.61	0.71	0.81	0.91	0.53	0.63	0.73	0.83	0.35	0.44	0.53	0.63	
		PI	1.20	1.21	1.21	1.20	1.20	1.20	1.20	1.20	1.20	1.20	1.20	1.20	1.19	1.19	1.19	1.19	
	77	TC	5.81	5.86	5.92	5.98	6.18	6.18	6.18	6.24	6.35	6.35	6.35	6.35	6.84	6.84	6.84	6.84	
		S/T	0.79	0.90	1.00	1.00	0.61	0.72	0.83	0.93	0.53	0.64	0.74	0.85	0.34	0.44	0.54	0.64	
		PI	1.33	1.33	1.33	1.33	1.33	1.33	1.33	1.33	1.33	1.33	1.33	1.33	1.33	1.33	1.33	1.33	
	86	TC	5.55	5.61	5.66	5.72	5.89	5.89	5.89	5.95	6.07	6.07	6.07	6.07	6.53	6.53	6.53	6.53	
		S/T	0.80	0.92	1.00	1.00	0.62	0.73	0.85	0.96	0.53	0.64	0.76	0.87	0.34	0.44	0.55	0.65	
		PI	1.45	1.45	1.45	1.45	1.45	1.45	1.45	1.45	1.45	1.45	1.45	1.45	1.46	1.46	1.46	1.46	
	95	TC	5.26	5.32	5.38	5.43	5.61	5.61	5.61	5.66	5.78	5.78	5.78	5.78	6.24	6.24	6.24	6.24	
		S/T	0.82	0.94	1.00	1.00	0.63	0.75	0.87	0.98	0.54	0.66	0.77	0.88	0.34	0.44	0.55	0.66	
		PI	1.59	1.59	1.59	1.59	1.59	1.59	1.59	1.59	1.60	1.60	1.60	1.60	1.61	1.61	1.61	1.61	
	104	TC	4.92	4.98	5.03	5.09	5.24	5.24	5.26	5.32	5.41	5.41	5.45	5.51	5.84	5.84	5.84	5.84	
		S/T	0.85	0.99	1.00	1.00	0.65	0.78	0.90	1.00	0.55	0.68	0.80	0.93	0.33	0.45	0.57	0.69	
		PI	1.75	1.75	1.75	1.75	1.76	1.76	1.76	1.76	1.76	1.76	1.76	1.76	1.78	1.78	1.78	1.78	
	114.8	TC	4.56	4.62	4.68	4.73	4.85	4.85	4.90	4.96	5.02	5.02	5.02	5.07	5.42	5.42	5.42	5.42	
		S/T	0.87	1.00	1.00	1.00	0.65	0.79	0.92	1.00	0.55	0.69	0.82	0.95	0.33	0.45	0.57	0.70	
		PI	1.95	1.95	1.95	1.95	1.96	1.96	1.96	1.96	1.96	1.96	1.96	1.96	1.98	1.98	1.98	1.98	
	122	TC	4.28	4.33	4.39	4.45	4.56	4.56	4.62	4.68	4.70	4.70	4.76	4.76	5.10	5.10	5.10	5.10	
		S/T	0.89	1.00	1.00	1.00	0.67	0.81	0.95	1.00	0.56	0.70	0.85	0.98	0.33	0.46	0.59	0.72	
		PI	2.11	2.11	2.11	2.11	2.12	2.12	2.12	2.12	2.13	2.13	2.13	2.13	2.14	2.14	2.14	2.14	
	765	5	TC	6.51	6.57	6.63	6.69	6.85	6.85	6.91	6.97	7.03	7.03	7.03	7.09	7.45	7.45	7.45	7.45
			S/T	0.82	0.96	0.98	1.00	0.63	0.75	0.88	0.97	0.53	0.66	0.78	0.90	0.32	0.43	0.55	0.67
			PI	1.13	1.13	1.13	1.13	1.12	1.12	1.12	1.12	1.12	1.12	1.12	1.12	1.13	1.13	1.13	1.13
		14	TC	6.48	6.54	6.59	6.65	6.81	6.81	6.87	6.93	6.99	6.99	6.99	7.05	7.42	7.42	7.42	7.42
			S/T	0.82	0.96	0.99	1.00	0.63	0.76	0.88	0.97	0.53	0.66	0.79	0.90	0.32	0.44	0.55	0.67
			PI	1.13	1.13	1.13	1.13	1.12	1.12	1.12	1.12	1.12	1.12	1.12	1.12	1.13	1.13	1.13	1.13
23		TC	6.44	6.50	6.56	6.62	6.78	6.78	6.84	6.90	6.97	6.97	6.97	7.02	7.40	7.40	7.40	7.40	
		S/T	0.83	0.97	0.99	1.00	0.63	0.76	0.89	0.98	0.54	0.66	0.79	0.91	0.32	0.44	0.56	0.67	
		PI	1.12	1.12	1.12	1.12	1.12	1.12	1.12	1.12	1.12	1.12	1.12	1.12	1.13	1.13	1.13	1.13	
32		TC	6.40	6.46	6.52	6.58	6.76	6.76	6.82	6.88	6.95	6.95	6.95	7.01	7.39	7.39	7.39	7.39	
		S/T	0.83	0.97	1.00	1.00	0.64	0.76	0.89	0.98	0.54	0.67	0.79	0.91	0.32	0.44	0.56	0.68	
		PI	1.13	1.13	1.13	1.13	1.12	1.12	1.12	1.12	1.13	1.13	1.13	1.13	1.13	1.13	1.13	1.13	
41		TC	6.37	6.43	6.49	6.55	6.73	6.73	6.79	6.85	6.92	6.92	6.92	6.98	7.39	7.39	7.39	7.39	
		S/T	0.84	0.98	1.00	1.00	0.64	0.77	0.90	0.99	0.54	0.67	0.80	0.92	0.33	0.44	0.56	0.68	
		PI	1.14	1.14	1.14	1.14	1.13	1.13	1.13	1.13	1.14	1.14	1.14	1.14	1.14	1.14	1.14	1.14	
50		TC	6.33	6.39	6.45	6.51	6.70	6.70	6.76	6.82	6.90	6.90	6.90	6.95	7.37	7.37	7.37	7.37	
		S/T	0.84	0.98	1.00	1.00	0.64	0.77	0.90	0.99	0.54	0.67	0.80	0.92	0.33	0.45	0.56	0.68	
		PI	1.16	1.16	1.16	1.16	1.15	1.15	1.15	1.15	1.15	1.15	1.15	1.15	1.16	1.16	1.16	1.16	
59		TC	6.28	6.34	6.40	6.46	6.66	6.66	6.71	6.77	6.85	6.85	6.85	6.91	7.34	7.34	7.34	7.34	
		S/T	0.85	0.99	1.00	1.00	0.65	0.78	0.91	1.00	0.55	0.68	0.81	0.93	0.33	0.45	0.57	0.69	
		PI	1.19	1.19	1.19	1.19	1.18	1.18	1.18	1.18	1.18	1.18	1.18	1.18	1.18	1.18	1.18	1.18	
68		TC	6.21	6.27	6.33	6.38	6.58	6.58	6.64	6.70	6.79	6.79	6.84	7.28	7.28	7.28	7.28		
		S/T	0.85	0.99	1.00	1.00	0.65	0.78	0.91	1.00	0.55	0.68	0.81	0.93	0.33	0.45	0.57	0.69	
		PI	1.23	1.23	1.23	1.23	1.22	1.22	1.22	1.22	1.22	1.22	1.22	1.22	1.22	1.22	1.22	1.22	
77		TC	5.92	5.98	6.04	6.10	6.30	6.30	6.35	6.41	6.50	6.50	6.50	6.56	6.99	6.99	6.99	6.99	
		S/T	0.87	1.00	1.00	1.00	0.66	0.79											

883	5	TC	6.63	6.69	6.75	6.82	7.00	7.00	7.06	7.12	7.15	7.15	7.15	7.21	7.59	7.59	7.59	7.59
		S/T	0.87	0.97	1.00	1.00	0.65	0.79	0.94	0.98	0.55	0.69	0.83	0.97	0.31	0.44	0.57	0.70
		PI	1.15	1.15	1.15	1.15	1.15	1.15	1.15	1.15	1.14	1.14	1.14	1.14	1.15	1.15	1.15	1.15
	14	TC	6.59	6.65	6.71	6.77	6.96	6.96	7.02	7.08	7.11	7.11	7.11	7.17	7.57	7.57	7.57	7.57
		S/T	0.87	0.97	1.00	1.00	0.65	0.80	0.94	0.98	0.55	0.69	0.83	0.97	0.31	0.45	0.57	0.71
		PI	1.14	1.14	1.14	1.14	1.15	1.15	1.15	1.15	1.14	1.14	1.14	1.14	1.15	1.15	1.15	1.15
	23	TC	6.56	6.62	6.67	6.73	6.93	6.93	6.99	7.05	7.08	7.08	7.08	7.14	7.55	7.55	7.55	7.55
		S/T	0.88	0.98	1.00	1.00	0.65	0.80	0.95	0.99	0.56	0.69	0.84	0.98	0.31	0.45	0.58	0.71
		PI	1.14	1.14	1.14	1.14	1.15	1.15	1.15	1.15	1.14	1.14	1.14	1.14	1.15	1.15	1.15	1.15
	32	TC	6.52	6.58	6.64	6.70	6.91	6.91	6.96	7.02	7.06	7.06	7.06	7.12	7.54	7.54	7.54	7.54
		S/T	0.88	0.98	1.00	1.00	0.66	0.80	0.95	0.99	0.56	0.70	0.84	0.98	0.31	0.45	0.58	0.72
		PI	1.15	1.15	1.15	1.15	1.15	1.15	1.15	1.15	1.15	1.15	1.15	1.15	1.15	1.15	1.15	1.15
	41	TC	6.49	6.55	6.61	6.67	6.88	6.88	6.94	7.00	7.04	7.04	7.04	7.10	7.53	7.53	7.53	7.53
		S/T	0.89	0.99	1.00	1.00	0.66	0.81	0.96	1.00	0.56	0.70	0.85	0.99	0.32	0.45	0.58	0.72
		PI	1.16	1.16	1.16	1.16	1.16	1.16	1.16	1.16	1.15	1.15	1.15	1.15	1.16	1.16	1.16	1.16
	50	TC	6.45	6.51	6.57	6.63	6.85	6.85	6.91	6.96	7.01	7.01	7.01	7.07	7.52	7.52	7.52	7.52
		S/T	0.89	0.99	1.00	1.00	0.66	0.81	0.96	1.00	0.56	0.70	0.85	0.99	0.32	0.46	0.58	0.72
		PI	1.18	1.18	1.18	1.18	1.18	1.18	1.18	1.18	1.17	1.17	1.17	1.17	1.18	1.18	1.18	1.18
	59	TC	6.40	6.46	6.51	6.57	6.80	6.80	6.86	6.92	6.97	6.97	6.97	7.03	7.48	7.48	7.48	7.48
		S/T	0.90	1.00	1.00	1.00	0.67	0.82	0.97	1.00	0.57	0.71	0.86	1.00	0.32	0.46	0.59	0.73
		PI	1.21	1.21	1.21	1.21	1.21	1.21	1.21	1.21	1.20	1.20	1.20	1.20	1.20	1.20	1.20	1.20
	68	TC	6.33	6.38	6.44	6.50	6.73	6.73	6.79	6.84	6.90	6.90	6.90	6.96	7.42	7.42	7.42	7.42
		S/T	0.90	1.00	1.00	1.00	0.67	0.82	0.97	1.00	0.57	0.71	0.86	1.00	0.32	0.46	0.59	0.73
		PI	1.25	1.25	1.25	1.25	1.25	1.25	1.25	1.25	1.24	1.24	1.24	1.24	1.24	1.24	1.24	1.24
	77	TC	6.04	6.10	6.15	6.21	6.41	6.41	6.47	6.53	6.61	6.61	6.61	6.67	7.10	7.10	7.10	7.10
		S/T	0.92	1.00	1.00	1.00	0.69	0.84	0.99	1.00	0.57	0.73	0.88	1.00	0.32	0.46	0.60	0.75
		PI	1.38	1.38	1.38	1.38	1.38	1.38	1.38	1.38	1.38	1.38	1.38	1.38	1.38	1.38	1.38	1.38
	86	TC	5.75	5.81	5.87	5.92	6.12	6.12	6.18	6.24	6.30	6.30	6.35	6.41	6.79	6.79	6.79	6.79
		S/T	0.95	1.00	1.00	1.00	0.70	0.86	1.00	1.00	0.58	0.74	0.90	1.00	0.32	0.47	0.61	0.76
		PI	1.50	1.50	1.50	1.50	1.51	1.51	1.51	1.51	1.51	1.51	1.51	1.51	1.52	1.52	1.52	1.52
	95	TC	5.46	5.52	5.58	5.64	5.81	5.87	5.92	5.98	6.01	6.01	6.10	6.15	6.47	6.47	6.47	6.47
		S/T	0.97	1.00	1.00	1.00	0.71	0.88	1.00	1.00	0.59	0.76	0.92	1.00	0.31	0.47	0.63	0.78
		PI	1.65	1.65	1.65	1.65	1.65	1.65	1.65	1.65	1.66	1.66	1.66	1.66	1.67	1.67	1.67	1.67
	104	TC	5.14	5.19	5.25	5.31	5.47	5.53	5.58	5.64	5.66	5.66	5.73	5.79	6.10	6.10	6.10	6.10
		S/T	1.00	1.00	1.00	1.00	0.74	0.92	1.00	1.00	0.61	0.79	0.97	1.00	0.31	0.48	0.65	0.90
		PI	1.83	1.83	1.83	1.83	1.83	1.83	1.83	1.83	1.84	1.84	1.84	1.84	1.85	1.85	1.85	1.85
	114.8	TC	4.76	4.82	4.88	4.93	5.08	5.13	5.19	5.25	5.25	5.25	5.31	5.36	5.68	5.68	5.68	5.68
		S/T	1.00	1.00	1.00	1.00	0.75	0.94	1.00	1.00	0.62	0.81	0.99	1.00	0.31	0.48	0.66	0.92
		PI	2.03	2.03	2.03	2.03	2.04	2.04	2.04	2.04	2.04	2.04	2.04	2.04	2.06	2.06	2.06	2.06
	122	TC	4.47	4.53	4.59	4.65	4.76	4.82	4.88	4.93	4.93	4.93	4.99	5.05	5.33	5.33	5.33	5.33
		S/T	1.00	1.00	1.00	1.00	0.77	0.98	1.00	1.00	0.63	0.83	1.00	1.00	0.30	0.49	0.68	0.97
		PI	2.20	2.20	2.20	2.20	2.21	2.21	2.21	2.21	2.22	2.22	2.22	2.22	2.23	2.23	2.23	2.23

TC:Total Cooling Capacity (kW)

S/T:Sensible Cooling Capacity Ratio

PI:Power Input(kW)

Note: The table shows the case where the operation frequency of a compressor is fixed.

MVB-24HWFN1-M+MOD30-24HFN1-MU0W																			
INDOOR AIR FLOW (CFM)	OUTDOOR DB(°F)	ID WB (°F)	60.8				64.4				66.2				71.6				
			ID DB (°F)	73.4	77.0	80.6	84.2	73.4	77.0	80.6	84.2	73.4	77.0	80.6	84.2	73.4	77.0	80.6	84.2
589	5	TC	6.77	6.79	6.85	6.91	7.12	7.24	7.30	7.36	7.30	7.30	7.30	7.30	7.74	7.74	7.74	7.74	
		S/T	0.73	0.83	0.93	0.97	0.58	0.67	0.76	0.86	0.50	0.60	0.69	0.78	0.34	0.42	0.51	0.60	
		PI	1.17	1.16	1.16	1.17	1.16	1.16	1.16	1.16	1.16	1.16	1.16	1.16	1.16	1.16	1.16	1.16	1.16
	14	TC	6.73	6.75	6.81	6.87	7.08	7.20	7.26	7.32	7.26	7.26	7.26	7.26	7.72	7.72	7.72	7.72	
		S/T	0.74	0.83	0.93	0.97	0.58	0.68	0.77	0.86	0.50	0.60	0.69	0.79	0.34	0.43	0.51	0.60	
		PI	1.16	1.16	1.16	1.16	1.16	1.16	1.16	1.16	1.16	1.16	1.16	1.16	1.16	1.16	1.16	1.16	1.16
	23	TC	6.69	6.71	6.77	6.83	7.06	7.18	7.24	7.29	7.24	7.24	7.24	7.24	7.70	7.70	7.70	7.70	
		S/T	0.74	0.84	0.94	0.98	0.59	0.68	0.77	0.87	0.51	0.60	0.69	0.79	0.34	0.43	0.52	0.60	
		PI	1.16	1.15	1.15	1.16	1.16	1.16	1.16	1.16	1.16	1.16	1.16	1.16	1.16	1.16	1.16	1.16	1.16
	32	TC	6.66	6.68	6.74	6.79	7.03	7.15	7.21	7.27	7.22	7.22	7.22	7.22	7.69	7.69	7.69	7.69	
		S/T	0.74	0.84	0.94	0.98	0.59	0.68	0.77	0.87	0.51	0.61	0.70	0.79	0.34	0.43	0.52	0.61	
		PI	1.16	1.16	1.16	1.16	1.16	1.16	1.16	1.16	1.17	1.17	1.17	1.17	1.17	1.17	1.17	1.17	1.17
	41	TC	6.63	6.64	6.70	6.76	7.00	7.12	7.18	7.24	7.19	7.19	7.19	7.19	7.69	7.69	7.69	7.69	
		S/T	0.75	0.85	0.95	0.99	0.59	0.69	0.78	0.88	0.51	0.61	0.70	0.80	0.34	0.43	0.52	0.61	
		PI	1.17	1.17	1.17	1.17	1.17	1.17	1.17	1.17	1.18	1.18	1.18	1.18	1.17	1.17	1.17	1.17	1.17
	50	TC	6.59	6.60	6.66	6.72	6.97	7.09	7.15	7.21	7.16	7.16	7.16	7.16	7.67	7.67	7.67	7.67	
		S/T	0.75	0.85	0.95	0.99	0.59	0.69	0.78	0.88	0.51	0.61	0.70	0.80	0.35	0.44	0.52	0.61	
		PI	1.19	1.19	1.19	1.19	1.19	1.19	1.19	1.19	1.19	1.19	1.19	1.19	1.19	1.19	1.19	1.19	1.19
	59	TC	6.53	6.55	6.61	6.66	6.92	7.04	7.10	7.16	7.12	7.12	7.12	7.12	7.63	7.63	7.63	7.63	
		S/T	0.76	0.86	0.96	1.00	0.60	0.69	0.79	0.89	0.52	0.62	0.71	0.81	0.35	0.44	0.53	0.62	
		PI	1.22	1.22	1.22	1.22	1.22	1.22	1.22	1.22	1.22	1.22	1.22	1.22	1.21	1.21	1.21	1.21	
	68	TC	6.46	6.47	6.53	6.59	6.85	6.85	6.85	6.91	7.05	7.05	7.05	7.05	7.57	7.57	7.57	7.57	
		S/T	0.76	0.86	0.96	1.00	0.60	0.70	0.79	0.89	0.52	0.62	0.71	0.81	0.35	0.44	0.53	0.62	
		PI	1.27	1.26	1.26	1.27	1.26	1.26	1.26	1.26	1.26	1.26	1.26	1.26	1.25	1.25	1.25	1.25	
	77	TC	6.16	6.16	6.22	6.27	6.53	6.53	6.53	6.59	6.73	6.73	6.73	6.73	7.25	7.25	7.25	7.25	
		S/T	0.77	0.88	0.99	1.00	0.60	0.71	0.81	0.91	0.53	0.63	0.73	0.83	0.35	0.44	0.53	0.62	
		PI	1.40	1.40	1.40	1.40	1.40	1.40	1.40	1.40	1.40	1.40	1.40	1.40	1.40	1.40	1.40	1.40	
	86	TC	5.87	5.93	5.99	6.04	6.24	6.24	6.24	6.30	6.45	6.45	6.45	6.45	6.93	6.93	6.93	6.93	
		S/T	0.79	0.90	1.00	1.00	0.61	0.72	0.83	0.93	0.53	0.63	0.74	0.84	0.34	0.44	0.54	0.63	
		PI	1.52	1.52	1.52	1.52	1.53	1.53	1.53	1.53	1.53	1.53	1.53	1.53	1.53	1.53	1.53	1.53	1.53
	95	TC	5.58	5.64	5.70	5.76	5.93	5.93	5.93	5.99	6.13	6.13	6.22	6.13	6.59	6.59	6.59	6.59	
		S/T	0.80	0.92	1.00	1.00	0.62	0.73	0.85	0.95	0.53	0.64	0.75	0.86	0.34	0.44	0.54	0.65	
		PI	1.67	1.67	1.67	1.67	1.67	1.67	1.67	1.67	1.68	1.68	1.68	1.68	1.69	1.69	1.69	1.69	
	104	TC	5.19	5.24	5.30	5.36	5.52	5.52	5.54	5.60	5.70	5.70	5.75	5.73	6.16	6.16	6.16	6.16	
		S/T	0.83	0.96	1.00	1.00	0.63	0.76	0.88	1.00	0.54	0.66	0.78	0.90	0.33	0.45	0.56	0.67	
		PI	1.84	1.84	1.84	1.84	1.85	1.85	1.85	1.85	1.85	1.85	1.85	1.85	1.87	1.87	1.87	1.87	
	114.8	TC	4.80	4.86	4.91	4.97	5.11	5.11	5.17	5.23	5.28	5.28	5.28	5.34	5.74	5.74	5.74	5.74	
		S/T	0.85	0.98	1.00	1.00	0.64	0.77	0.90	1.00	0.55	0.67	0.80	0.92	0.33	0.45	0.56	0.68	
		PI	2.05	2.05	2.05	2.05	2.06	2.06	2.06	2.06	2.06	2.06	2.06	2.06	2.08	2.08	2.08	2.08	
	122	TC	4.52	4.57	4.63	4.69	4.83	4.83	4.89	4.94	4.97	4.97	4.97	5.03	5.40	5.40	5.40	5.40	
		S/T	0.87	1.00	1.00	1.00	0.65	0.79	0.92	1.00	0.56	0.69	0.82	0.95	0.33	0.45	0.57	0.70	
		PI	2.22	2.22	2.22	2.22	2.23	2.23	2.23	2.23	2.24	2.24	2.24	2.24	2.25	2.25	2.25	2.25	
	765	5	TC	6.91	6.97	7.03	7.09	7.24	7.24	7.30	7.36	7.45	7.45	7.45	7.54	7.89	7.89	7.89	7.89
			S/T	0.80	0.93	0.98	1.00	0.62	0.73	0.85	0.97	0.52	0.65	0.76	0.87	0.32	0.43	0.54	0.65
			PI	1.19	1.19	1.19	1.19	1.19	1.19	1.19	1.19	1.19	1.19	1.19	1.19	1.19	1.19	1.19	1.19
		14	TC	6.87	6.93	6.99	7.05	7.20	7.20	7.26	7.32	7.41	7.41	7.41	7.50	7.87	7.87	7.87	7.87
			S/T	0.81	0.93	0.99	1.00	0.62	0.74	0.85	0.97	0.52	0.65	0.77	0.87	0.32	0.44	0.54	0.65
			PI	1.18	1.18	1.18	1.18	1.19	1.19	1.19	1.19	1.19	1.19	1.19	1.19	1.19	1.19	1.19	1.19
23		TC	6.83	6.89	6.95	7.01	7.18	7.18	7.24	7.29	7.39	7.39	7.39	7.48	7.85	7.85	7.85	7.85	
		S/T	0.81	0.94	0.99	1.00	0.62	0.74	0.86	0.98	0.53	0.65	0.77	0.88	0.32	0.44	0.55	0.65	
		PI	1.18	1.18	1.18	1.18	1.19	1.19	1.19	1.19	1.19	1.19	1.19	1.19	1.19	1.19	1.19	1.19	
32		TC	6.80	6.86	6.92	6.97	7.15	7.15	7.21	7.27	7.37	7.37	7.37	7.45	7.84	7.84	7.84	7.84	
		S/T	0.81	0.94	1.00	1.00	0.63	0.74	0.86	0.98	0.53	0.66	0.77	0.88	0.32	0.44	0.55	0.66	
		PI	1.19	1.19	1.19	1.19	1.19	1.19	1.19	1.19	1.19	1.19	1.19	1.19	1.19	1.19	1.19	1.19	
41		TC	6.76	6.82	6.88	6.94	7.12	7.12	7.18	7.24	7.34	7.34	7.34	7.43	7.83	7.83	7.83	7.83	
		S/T	0.82	0.95	1.00	1.00	0.63	0.75	0.87	0.99	0.53	0.66	0.78	0.89	0.33	0.44	0.55	0.66	
		PI	1.20	1.20	1.20	1.20	1.20	1.20	1.20	1.20	1.20	1.20	1.20	1.20	1.20	1.20	1.20	1.20	
50		TC	6.72	6.78	6.84	6.90	7.09	7.09	7.15	7.21	7.31	7.31	7.31	7.40	7.81	7.81	7.81	7.81	
		S/T	0.82	0.95	1.00	1.00	0.63	0.75	0.87	0.99	0.53	0.66	0.78	0.89	0.33	0.45	0.55	0.66	
		PI	1.22	1.22	1.22	1.22	1.22	1.22	1.22	1.22	1.22	1.22	1.22	1.22	1.22	1.22	1.22	1.22	
59		TC	6.67	6.73	6.78	6.84	7.04	7.04	7.10	7.16	7.27	7.27	7.27	7.35	7.78	7.78	7.78	7.78	
		S/T	0.83	0.96	1.00	1.00	0.64	0.76	0.88	1.00	0.54	0.67	0.79	0.90	0.33	0.45	0.56	0.67	
		PI	1.25	1.25	1.25	1.25	1.25	1.25	1.25	1.25	1.25	1.25	1.25	1.25	1.24	1.24	1.24	1.24	
68		TC	6.59	6.65	6.71	6.76	6.97	6.97	7.02	7.08	7.20	7.20	7.20	7.28	7.71	7.71	7.71	7.71	
		S/T	0.83	0.96	1.00	1.00	0.64	0.76	0.88	1.00	0.54	0.67	0.79	0.90	0.33	0.45	0.56	0.67	
		PI	1.29	1.29	1.29	1.29	1.29	1.29	1.29	1.29	1.29	1.29	1.29	1.29	1.28	1.28	1.28	1.28	
77		TC	6.28	6.33	6.39	6.45	6.68	6.68	6.74	6.79	6.88	6.88	6.88	6.94	7.40	7.40	7.40	7.40	

883	5	TC	7.03	7.09	7.15	7.21	7.39	7.39	7.45	7.51	7.57	7.57	7.57	7.66	8.04	8.04	8.04	8.04
		S/T	0.85	0.97	1.00	1.00	0.64	0.77	0.91	0.98	0.54	0.68	0.81	0.94	0.32	0.43	0.56	0.69
		PI	1.22	1.22	1.22	1.22	1.22	1.22	1.22	1.22	1.22	1.22	1.22	1.22	1.22	1.21	1.21	1.21
	14	TC	6.99	7.05	7.11	7.17	7.35	7.35	7.41	7.47	7.53	7.53	7.53	7.62	8.01	8.01	8.01	8.01
		S/T	0.85	0.97	1.00	1.00	0.64	0.78	0.91	0.98	0.54	0.68	0.82	0.94	0.32	0.44	0.56	0.69
		PI	1.21	1.21	1.21	1.21	1.21	1.21	1.21	1.21	1.22	1.22	1.22	1.22	1.21	1.21	1.21	1.21
	23	TC	6.95	7.01	7.07	7.13	7.32	7.32	7.38	7.44	7.50	7.50	7.50	7.59	7.99	7.99	7.99	7.99
		S/T	0.86	0.98	1.00	1.00	0.64	0.78	0.92	0.99	0.55	0.68	0.82	0.95	0.32	0.44	0.57	0.69
		PI	1.21	1.21	1.21	1.21	1.21	1.21	1.21	1.21	1.22	1.22	1.22	1.22	1.22	1.22	1.22	1.22
	32	TC	6.92	6.97	7.03	7.09	7.30	7.30	7.36	7.41	7.48	7.48	7.48	7.57	7.99	7.99	7.99	7.99
		S/T	0.86	0.98	1.00	1.00	0.65	0.78	0.92	0.99	0.55	0.69	0.82	0.95	0.32	0.44	0.57	0.70
		PI	1.21	1.21	1.21	1.21	1.22	1.22	1.22	1.22	1.22	1.22	1.22	1.22	1.22	1.22	1.22	1.22
	41	TC	6.88	6.94	7.00	7.06	7.27	7.27	7.33	7.39	7.46	7.46	7.46	7.55	7.98	7.98	7.98	7.98
		S/T	0.87	0.99	1.00	1.00	0.65	0.79	0.93	1.00	0.55	0.69	0.83	0.96	0.33	0.44	0.57	0.70
		PI	1.22	1.22	1.22	1.22	1.23	1.23	1.23	1.23	1.23	1.23	1.23	1.23	1.23	1.23	1.23	1.23
	50	TC	6.84	6.90	6.96	7.02	7.23	7.23	7.29	7.35	7.43	7.43	7.43	7.52	7.96	7.96	7.96	7.96
		S/T	0.87	0.99	1.00	1.00	0.65	0.79	0.93	1.00	0.55	0.69	0.83	0.96	0.33	0.45	0.57	0.70
		PI	1.25	1.25	1.25	1.25	1.25	1.25	1.25	1.25	1.25	1.25	1.25	1.25	1.25	1.25	1.25	1.25
	59	TC	6.78	6.84	6.90	6.96	7.19	7.19	7.24	7.30	7.38	7.38	7.38	7.47	7.93	7.93	7.93	7.93
		S/T	0.88	1.00	1.00	1.00	0.66	0.80	0.94	1.00	0.56	0.70	0.84	0.97	0.33	0.45	0.58	0.71
		PI	1.28	1.28	1.28	1.28	1.28	1.28	1.28	1.28	1.28	1.28	1.28	1.28	1.27	1.27	1.27	1.27
	68	TC	6.71	6.76	6.82	6.88	7.11	7.11	7.17	7.23	7.31	7.31	7.31	7.40	7.86	7.86	7.86	7.86
		S/T	0.88	1.00	1.00	1.00	0.66	0.80	0.94	1.00	0.56	0.70	0.84	0.97	0.33	0.45	0.58	0.71
		PI	1.32	1.32	1.32	1.32	1.32	1.32	1.32	1.32	1.32	1.32	1.32	1.32	1.31	1.31	1.31	1.31
	77	TC	6.39	6.45	6.51	6.56	6.79	6.79	6.85	6.91	6.99	6.99	6.99	7.05	7.51	7.51	7.51	7.51
		S/T	0.90	1.00	1.00	1.00	0.67	0.82	0.96	1.00	0.57	0.71	0.85	0.99	0.32	0.46	0.59	0.73
		PI	1.46	1.46	1.46	1.46	1.46	1.46	1.46	1.46	1.46	1.46	1.46	1.46	1.46	1.46	1.46	1.46
	86	TC	6.10	6.16	6.22	6.28	6.48	6.48	6.53	6.59	6.68	6.68	6.68	6.74	7.20	7.20	7.20	7.20
		S/T	0.92	1.00	1.00	1.00	0.68	0.84	0.99	1.00	0.57	0.72	0.87	1.00	0.32	0.46	0.60	0.74
		PI	1.59	1.59	1.59	1.59	1.60	1.60	1.60	1.60	1.60	1.60	1.60	1.60	1.61	1.61	1.61	1.61
	95	TC	5.79	5.84	5.90	5.96	6.16	6.16	6.22	6.28	6.36	6.36	6.45	6.51	6.85	6.85	6.85	6.85
		S/T	0.95	1.00	1.00	1.00	0.70	0.86	1.00	1.00	0.58	0.74	0.89	1.00	0.32	0.47	0.61	0.76
		PI	1.75	1.75	1.75	1.75	1.75	1.75	1.75	1.75	1.76	1.76	1.76	1.76	1.77	1.77	1.77	1.77
	104	TC	5.46	5.52	5.58	5.63	5.82	5.85	5.91	5.96	6.01	6.01	6.08	6.14	6.49	6.49	6.49	6.49
		S/T	0.99	1.00	1.00	1.00	0.72	0.90	1.00	1.00	0.60	0.77	0.94	1.00	0.31	0.47	0.63	0.90
		PI	1.93	1.93	1.93	1.93	1.93	1.93	1.93	1.93	1.94	1.94	1.94	1.94	1.96	1.96	1.96	1.96
	114.8	TC	5.05	5.11	5.17	5.22	5.40	5.45	5.51	5.57	5.57	5.57	5.63	5.69	6.03	6.03	6.03	6.03
		S/T	1.00	1.00	1.00	1.00	0.73	0.92	1.00	1.00	0.60	0.79	0.96	1.00	0.31	0.48	0.65	0.92
		PI	2.14	2.14	2.14	2.14	2.15	2.15	2.15	2.15	2.16	2.16	2.16	2.16	2.18	2.18	2.18	2.18
	122	TC	4.73	4.79	4.85	4.91	5.08	5.14	5.20	5.25	5.25	5.25	5.31	5.37	5.69	5.69	5.69	5.69
		S/T	1.00	1.00	1.00	1.00	0.75	0.95	1.00	1.00	0.62	0.81	1.00	1.00	0.31	0.48	0.66	0.97
		PI	2.33	2.33	2.33	2.33	2.34	2.34	2.34	2.34	2.34	2.34	2.34	2.34	2.36	2.36	2.36	2.36

TC:Total Cooling Capacity (kW)

S/T:Sensible Cooling Capacity Ratio

PI:Power Input(kW)

Note: The table shows the case where the operation frequency of a compressor is fixed.

MVB-36HWFN1-M																			
INDOOR AIR FLOW (CFM)	OUTDOOR DB(°F)	ID WB (°F)	60.8				64.4				66.2				71.6				
			ID DB (°F)	73.4	77.0	80.6	84.2	73.4	77.0	80.6	84.2	73.4	77.0	80.6	84.2	73.4	77.0	80.6	84.2
		824	5	TC	11.05	11.06	11.18	11.30	11.63	11.87	11.87	11.99	11.90	11.90	11.90	11.90	12.65	12.65	12.65
S/T	0.70			0.78	0.87	0.95	0.56	0.64	0.72	0.80	0.50	0.58	0.66	0.73	0.35	0.42	0.49	0.57	
PI	2.89			2.90	2.90	2.89	2.88	2.88	2.88	2.88	2.88	2.88	2.88	2.88	2.87	2.87	2.87	2.87	
14	TC		10.99	11.00	11.11	11.23	11.56	11.80	11.80	11.92	11.84	11.84	11.84	11.84	12.60	12.60	12.60	12.60	
	S/T		0.71	0.79	0.87	0.95	0.56	0.65	0.73	0.81	0.50	0.58	0.66	0.74	0.35	0.43	0.49	0.57	
	PI		2.88	2.88	2.88	2.88	2.87	2.87	2.87	2.87	2.88	2.88	2.88	2.88	2.88	2.88	2.88	2.88	
23	TC		10.92	10.93	11.05	11.17	11.52	11.76	11.76	11.88	11.80	11.80	11.80	11.80	12.57	12.57	12.57	12.57	
	S/T		0.71	0.79	0.88	0.96	0.57	0.65	0.73	0.81	0.51	0.59	0.66	0.74	0.35	0.43	0.50	0.58	
	PI		2.87	2.88	2.88	2.88	2.87	2.87	2.87	2.87	2.88	2.88	2.88	2.88	2.88	2.88	2.88	2.88	
32	TC		10.87	10.87	10.99	11.11	11.47	11.71	11.71	11.83	11.77	11.77	11.77	11.77	12.56	12.56	12.56	12.56	
	S/T		0.72	0.79	0.88	0.96	0.57	0.65	0.74	0.81	0.51	0.59	0.67	0.74	0.35	0.43	0.50	0.58	
	PI		2.89	2.89	2.89	2.89	2.88	2.88	2.88	2.88	2.89	2.89	2.89	2.89	2.89	2.89	2.89	2.89	
41	TC		10.81	10.82	10.94	11.06	11.43	11.67	11.67	11.79	11.73	11.73	11.73	11.73	12.55	12.55	12.55	12.55	
	S/T		0.72	0.80	0.89	0.97	0.57	0.66	0.74	0.82	0.51	0.59	0.67	0.75	0.35	0.43	0.50	0.58	
	PI		2.91	2.92	2.92	2.91	2.91	2.91	2.91	2.91	2.91	2.91	2.91	2.91	2.91	2.91	2.91	2.91	
50	TC		10.75	10.75	10.87	10.99	11.38	11.61	11.61	11.73	11.68	11.68	11.68	11.68	12.52	12.52	12.52	12.52	
	S/T		0.72	0.80	0.89	0.97	0.57	0.66	0.74	0.82	0.51	0.59	0.67	0.75	0.36	0.44	0.50	0.58	
	PI		2.96	2.97	2.97	2.96	2.95	2.95	2.95	2.95	2.96	2.96	2.96	2.96	2.95	2.95	2.95	2.95	
59	TC		10.66	10.67	10.78	10.90	11.30	11.54	11.54	11.65	11.61	11.61	11.61	11.61	12.46	12.46	12.46	12.46	
	S/T		0.73	0.81	0.90	0.98	0.58	0.66	0.75	0.83	0.52	0.60	0.68	0.76	0.36	0.44	0.51	0.59	
	PI		3.03	3.04	3.04	3.03	3.02	3.02	3.02	3.02	3.02	3.02	3.02	3.02	3.01	3.01	3.01	3.01	
68	TC		10.54	10.55	10.66	10.78	11.18	11.41	11.41	11.50	11.50	11.50	11.50	11.50	12.36	12.36	12.36	12.36	
	S/T		0.73	0.81	0.90	0.98	0.58	0.67	0.75	0.83	0.52	0.60	0.68	0.76	0.36	0.44	0.51	0.59	
	PI		3.14	3.14	3.14	3.14	3.12	3.12	3.12	3.12	3.12	3.12	3.12	3.12	3.10	3.10	3.10	3.10	
77	TC		10.06	10.06	10.17	10.29	10.69	10.69	10.69	10.69	11.01	11.01	11.01	11.01	11.84	11.84	11.84	11.84	
	S/T		0.74	0.83	0.92	1.00	0.59	0.67	0.76	0.85	0.52	0.60	0.69	0.77	0.36	0.44	0.52	0.59	
	PI		3.46	3.46	3.46	3.46	3.46	3.46	3.46	3.46	3.46	3.46	3.46	3.46	3.46	3.46	3.46	3.46	
86	TC		9.57	9.57	9.66	9.74	10.20	10.20	10.20	10.20	10.49	10.49	10.49	10.49	11.32	11.32	11.32	11.32	
	S/T		0.75	0.84	0.94	1.00	0.59	0.68	0.77	0.87	0.52	0.61	0.70	0.79	0.35	0.44	0.52	0.60	
	PI		3.79	3.79	3.79	3.79	3.80	3.80	3.80	3.80	3.80	3.80	3.80	3.80	3.82	3.82	3.82	3.82	
95	TC		9.11	9.11	9.20	9.28	9.68	9.68	9.68	9.77	10.00	10.00	10.14	10.00	10.78	10.78	10.78	10.78	
	S/T		0.76	0.86	0.96	1.00	0.60	0.69	0.79	0.88	0.52	0.62	0.71	0.80	0.35	0.44	0.52	0.61	
	PI		4.14	4.14	4.14	4.14	4.16	4.16	4.16	4.16	4.16	4.16	4.17	4.16	4.19	4.19	4.19	4.19	
104	TC		8.49	8.53	8.62	8.70	9.05	9.05	9.05	9.13	9.34	9.34	9.41	9.34	10.08	10.08	10.08	10.08	
	S/T		0.78	0.89	1.00	1.00	0.61	0.72	0.82	0.92	0.53	0.63	0.73	0.84	0.34	0.44	0.53	0.63	
	PI		4.57	4.57	4.57	4.57	4.59	4.59	4.59	4.59	4.60	4.60	4.60	4.60	4.63	4.63	4.63	4.63	
114.8	TC		7.86	7.94	8.03	8.11	8.40	8.40	8.40	8.48	8.65	8.65	8.65	8.65	9.37	9.37	9.37	9.37	
	S/T		0.80	0.91	1.00	1.00	0.61	0.73	0.84	0.94	0.53	0.64	0.75	0.85	0.34	0.44	0.54	0.64	
	PI		5.08	5.08	5.08	5.08	5.11	5.11	5.11	5.11	5.12	5.12	5.12	5.12	5.16	5.16	5.16	5.16	
122	TC		7.37	7.46	7.54	7.63	7.88	7.88	7.88	7.97	8.14	8.14	8.14	8.14	8.82	8.82	8.82	8.82	
	S/T		0.82	0.94	1.00	1.00	0.62	0.74	0.86	0.97	0.54	0.65	0.77	0.88	0.34	0.44	0.55	0.65	
	PI		5.50	5.50	5.50	5.50	5.53	5.53	5.53	5.53	5.54	5.54	5.54	5.54	5.59	5.59	5.59	5.59	
1001	5		TC	11.28	11.28	11.40	11.52	11.87	11.87	11.87	11.99	12.15	12.15	12.15	12.15	12.92	12.92	12.92	12.92
			S/T	0.73	0.84	0.98	1.00	0.58	0.68	0.77	0.87	0.50	0.60	0.70	0.79	0.34	0.42	0.51	0.60
			PI	2.95	2.95	2.95	2.95	2.95	2.95	2.95	2.95	2.94	2.94	2.94	2.94	2.94	2.94	2.94	2.94
	14		TC	11.21	11.21	11.33	11.45	11.80	11.80	11.80	11.92	12.08	12.08	12.08	12.08	12.87	12.87	12.87	12.87
			S/T	0.74	0.84	0.99	1.00	0.58	0.68	0.78	0.87	0.50	0.60	0.70	0.80	0.34	0.43	0.51	0.60
			PI	2.94	2.94	2.94	2.94	2.94	2.94	2.94	2.94	2.93	2.93	2.93	2.93	2.94	2.94	2.94	2.94
	23	TC	11.14	11.14	11.26	11.38	11.76	11.76	11.76	11.88	12.04	12.04	12.04	12.04	12.84	12.84	12.84	12.84	
		S/T	0.74	0.85	0.99	1.00	0.59	0.68	0.78	0.88	0.51	0.60	0.70	0.80	0.34	0.43	0.52	0.60	
		PI	2.93	2.93	2.93	2.93	2.94	2.94	2.94	2.94	2.93	2.93	2.93	2.93	2.95	2.95	2.95	2.95	
	32	TC	11.09	11.09	11.21	11.32	11.71	11.71	11.71	11.83	12.01	12.01	12.01	12.01	12.83	12.83	12.83	12.83	
		S/T	0.74	0.85	1.00	1.00	0.59	0.69	0.78	0.88	0.51	0.61	0.71	0.80	0.34	0.43	0.52	0.61	
		PI	2.95	2.95	2.95	2.95	2.95	2.95	2.95	2.95	2.95	2.95	2.95	2.95	2.96	2.96	2.96	2.96	
	41	TC	11.03	11.03	11.15	11.27	11.67	11.67	11.67	11.79	11.97	11.97	11.97	11.97	12.82	12.82	12.82	12.82	
		S/T	0.75	0.86	1.00	1.00	0.59	0.69	0.79	0.89	0.51	0.61	0.71	0.81	0.34	0.43	0.52	0.61	
		PI	2.97	2.97	2.97	2.97	2.97	2.97	2.97	2.97	2.97	2.97	2.97	2.97	2.98	2.98	2.98	2.98	
	50	TC	10.96	10.96	11.08	11.20	11.61	11.61	11.61	11.73	11.92	11.92	11.92	11.92	12.78	12.78	12.78	12.78	
		S/T	0.75	0.86	1.00	1.00	0.59	0.69	0.79	0.89	0.51	0.61	0.71	0.81	0.35	0.44	0.52	0.61	
		PI	3.02	3.02	3.02	3.02	3.02	3.02	3.02	3.02	3.01	3.01	3.01	3.01	3.02	3.02	3.02	3.02	
	59	TC	10.87	10.87	10.99	11.11	11.54	11.54	11.54	11.65	11.85	11.85	11.85	11.85	12.73	12.73	12.73	12.73	
		S/T	0.76	0.87	0.97	1.00	0.60	0.70	0.80	0.90	0.52	0.62	0.72	0.82	0.35	0.44	0.53	0.62	
		PI	3.10	3.10	3.10	3.10	3.09	3.09	3.09	3.09	3.08	3.08	3.08	3.08	3.08	3.08	3.08	3.08	
	68	TC	10.75	10.75	10.87	10.98	11.41	11.41	11.41	11.53	11.73	11.73	11.73	11.73	12.62	12.62	12.62	12.62	
		S/T	0.76	0.87	0.97	1.00	0.60	0.70	0.80	0.90	0.52	0.62	0.72	0.82	0.35	0.44	0.53	0.62	
		PI	3.20	3.20	3.20	3.20	3.19	3.19	3.19	3.19	3.18	3.18	3.18	3.18	3.17	3.17	3.17	3.17	
	77	TC	10.26	10.38	10.49	10.61	10.90	10.90	10.90	11.01	11.21	11.21	11.21	11.21	12.07	12.07	12.07	12.07	
		S/T	0.78	0.88	0.99	1.00	0.61	0.71	0.82	0.92	0.53	0.63	0.73	0.83	0.34	0.44	0.53	0.63	
		PI	3.54	3.54	3.54	3.54	3.54	3.54	3.54	3.54	3.53	3.53	3.53	3.53	3.54	3.54	3.54	3.54	
	86	TC	9.77	9.86	9.95	10.03	10.41	10.41	10.41	10.52	10.72	10.72	10.72	10.72	11.53	11.53	11.53	11.53	
		S/T	0.79	0.90	1.00	1.00	0.61	0.72	0.83	0.94	0.53	0.64	0.74	0.85	0.34	0.44	0.54	0.64	
		PI	3.87	3.87	3.87	3.87	3.88	3.88	3.88	3.88	3.88	3.88	3.88	3.88	3.90	3.90	3.90	3.90	
	95	TC	9.29	9															

1177	5	TC	11.49	11.61	11.73	11.85	12.08	12.08	12.08	12.20	12.38	12.38	12.38	12.38	13.15	13.15	13.15	13.15
		S/T	0.78	0.89	1.00	1.00	0.60	0.71	0.82	0.98	0.52	0.63	0.73	0.84	0.33	0.42	0.53	0.63
		PI	3.02	3.02	3.02	3.02	3.01	3.01	3.01	3.01	3.00	3.00	3.00	3.00	3.00	3.00	3.00	3.00
	14	TC	11.42	11.54	11.66	11.78	12.01	12.01	12.01	12.13	12.32	12.32	12.32	12.32	13.11	13.11	13.11	13.11
		S/T	0.79	0.89	1.00	1.00	0.60	0.72	0.82	0.98	0.52	0.63	0.74	0.84	0.33	0.43	0.53	0.63
		PI	3.00	3.00	3.00	3.00	3.00	3.00	3.00	3.00	3.00	3.00	3.00	3.00	3.01	3.01	3.01	3.01
	23	TC	11.35	11.47	11.59	11.71	11.97	11.97	11.97	12.08	12.28	12.28	12.28	12.28	13.07	13.07	13.07	13.07
		S/T	0.79	0.90	1.00	1.00	0.60	0.72	0.83	0.99	0.53	0.63	0.74	0.85	0.33	0.43	0.54	0.63
		PI	3.00	3.00	3.00	3.00	3.00	3.00	3.00	3.00	3.00	3.00	3.00	3.00	3.01	3.01	3.01	3.01
	32	TC	11.29	11.41	11.53	11.65	11.92	11.92	11.92	12.04	12.24	12.24	12.24	12.24	13.06	13.06	13.06	13.06
		S/T	0.79	0.90	1.00	1.00	0.61	0.73	0.83	0.99	0.53	0.64	0.74	0.85	0.33	0.43	0.54	0.64
		PI	3.01	3.01	3.01	3.01	3.01	3.01	3.01	3.01	3.01	3.01	3.01	3.01	3.02	3.02	3.02	3.02
	41	TC	11.24	11.36	11.47	11.59	11.87	11.87	11.87	11.99	12.20	12.20	12.20	12.20	13.05	13.05	13.05	13.05
		S/T	0.80	0.91	1.00	1.00	0.61	0.73	0.84	1.00	0.53	0.64	0.75	0.86	0.33	0.43	0.54	0.64
		PI	3.04	3.04	3.04	3.04	3.04	3.04	3.04	3.04	3.03	3.03	3.03	3.03	3.04	3.04	3.04	3.04
	50	TC	11.17	11.29	11.40	11.52	11.82	11.82	11.82	11.94	12.15	12.15	12.15	12.15	13.02	13.02	13.02	13.02
		S/T	0.80	0.91	1.00	1.00	0.61	0.73	0.84	1.00	0.53	0.64	0.75	0.86	0.34	0.44	0.54	0.64
		PI	3.09	3.09	3.09	3.09	3.08	3.08	3.08	3.08	3.08	3.08	3.08	3.08	3.08	3.08	3.08	3.08
	59	TC	11.08	11.19	11.31	11.43	11.74	11.74	11.74	11.86	12.08	12.08	12.08	12.08	12.96	12.96	12.96	12.96
		S/T	0.81	0.92	1.00	1.00	0.62	0.74	0.85	0.96	0.54	0.65	0.76	0.87	0.34	0.44	0.55	0.65
		PI	3.16	3.16	3.16	3.16	3.16	3.16	3.16	3.16	3.15	3.15	3.15	3.15	3.15	3.15	3.15	3.15
	68	TC	10.95	11.07	11.18	11.30	11.61	11.61	11.61	11.73	11.96	11.96	11.96	11.96	12.85	12.85	12.85	12.85
		S/T	0.81	0.92	1.00	1.00	0.62	0.74	0.85	0.96	0.54	0.65	0.76	0.87	0.34	0.44	0.55	0.65
		PI	3.27	3.27	3.27	3.27	3.26	3.26	3.26	3.26	3.25	3.25	3.25	3.25	3.24	3.24	3.24	3.24
	77	TC	10.46	10.58	10.69	10.81	11.10	11.10	11.10	11.21	11.44	11.44	11.44	11.56	12.30	12.30	12.30	12.30
		S/T	0.82	0.94	1.00	1.00	0.63	0.75	0.87	0.99	0.54	0.66	0.77	0.89	0.34	0.44	0.55	0.66
		PI	3.61	3.61	3.61	3.61	3.61	3.61	3.61	3.61	3.61	3.61	3.61	3.61	3.61	3.61	3.61	3.61
	86	TC	9.98	10.06	10.18	10.29	10.61	10.61	10.72	10.84	10.92	10.92	10.92	11.04	11.76	11.76	11.76	11.76
		S/T	0.84	0.97	1.00	1.00	0.64	0.76	0.89	1.00	0.55	0.67	0.79	0.91	0.33	0.45	0.56	0.68
		PI	3.95	3.95	3.95	3.95	3.96	3.96	3.96	3.96	3.96	3.96	3.96	3.96	3.98	3.98	3.98	3.98
	95	TC	9.46	9.54	9.63	9.72	10.06	10.06	10.18	10.29	10.38	10.38	10.55	10.67	11.21	11.21	11.21	11.21
		S/T	0.86	0.99	1.00	1.00	0.65	0.78	0.91	1.00	0.55	0.68	0.80	0.93	0.33	0.45	0.57	0.69
		PI	4.32	4.32	4.32	4.32	4.33	4.33	4.33	4.33	4.34	4.34	4.35	4.34	4.37	4.37	4.37	4.37
	104	TC	8.91	9.00	9.08	9.17	9.49	9.49	9.59	9.69	9.79	9.79	9.89	9.99	10.60	10.60	10.60	10.60
		S/T	0.90	1.00	1.00	1.00	0.67	0.81	0.96	1.00	0.56	0.70	0.85	0.98	0.32	0.46	0.59	0.90
		PI	4.77	4.77	4.77	4.77	4.79	4.79	4.79	4.79	4.79	4.79	4.80	4.79	4.83	4.83	4.83	4.83
	114.8	TC	8.25	8.34	8.43	8.51	8.80	8.80	8.89	8.97	9.09	9.09	9.09	9.17	9.86	9.86	9.86	9.86
		S/T	0.91	1.00	1.00	1.00	0.68	0.83	0.98	1.00	0.57	0.72	0.87	1.00	0.32	0.46	0.60	0.92
		PI	5.30	5.30	5.30	5.30	5.33	5.33	5.33	5.33	5.34	5.34	5.34	5.34	5.38	5.38	5.38	5.38
	122	TC	7.74	7.82	7.91	7.99	8.28	8.28	8.37	8.45	8.57	8.57	8.57	8.66	8.74	9.29	9.29	9.29
		S/T	0.94	1.00	1.00	1.00	0.69	0.86	1.00	1.00	0.58	0.74	0.89	1.00	0.32	0.46	0.61	0.97
		PI	5.74	5.74	5.74	5.74	5.77	5.77	5.77	5.77	5.78	5.78	5.78	5.78	5.83	5.83	5.83	5.83

TC:Total Cooling Capacity (kW)

S/T:Sensible Cooling Capacity Ratio

PI:Power Input(kW)

Note: The table shows the case where the operation frequency of a compressor is fixed.

MVB-48HWFN1-M																		
INDOOR AIR FLOW (CFM)	OUTDOOR DB(°F)	ID WB (°F)	60.8				64.4				66.2				71.6			
			ID DB (°F)	73.4	77.0	80.6	84.2	73.4	77.0	80.6	84.2	73.4	77.0	80.6	84.2	73.4	77.0	80.6
1177	5	TC	14.70	14.69	14.84	14.99	15.46	15.79	15.79	15.94	15.84	15.84	15.84	15.84	16.83	16.83	16.83	16.83
		S/T	0.71	0.81	0.90	0.97	0.57	0.66	0.74	0.83	0.50	0.59	0.67	0.75	0.35	0.42	0.50	0.58
		PI	3.99	3.99	3.99	3.99	3.98	3.98	3.98	3.98	3.98	3.98	3.98	3.98	3.98	3.97	3.97	3.97
	14	TC	14.61	14.60	14.75	14.90	15.37	15.71	15.71	15.85	15.76	15.76	15.76	15.76	16.77	16.77	16.77	16.77
		S/T	0.72	0.82	0.90	0.97	0.57	0.66	0.75	0.83	0.50	0.59	0.67	0.76	0.35	0.43	0.50	0.58
		PI	3.97	3.97	3.97	3.97	3.97	3.97	3.97	3.97	3.97	3.97	3.97	3.97	3.97	3.97	3.97	3.97
	23	TC	14.52	14.51	14.66	14.81	15.31	15.65	15.65	15.79	15.70	15.70	15.70	15.70	16.73	16.73	16.73	16.73
		S/T	0.72	0.82	0.91	0.98	0.58	0.66	0.75	0.84	0.51	0.59	0.67	0.76	0.35	0.43	0.51	0.59
		PI	3.97	3.97	3.97	3.97	3.97	3.97	3.97	3.97	3.97	3.97	3.97	3.97	3.98	3.98	3.98	3.98
	32	TC	14.45	14.44	14.59	14.74	15.26	15.59	15.59	15.73	15.66	15.66	15.66	15.66	16.71	16.71	16.71	16.71
		S/T	0.73	0.82	0.91	0.98	0.58	0.67	0.75	0.84	0.51	0.60	0.68	0.76	0.35	0.43	0.51	0.59
		PI	3.98	3.98	3.98	3.98	3.98	3.98	3.98	3.98	3.98	3.98	3.98	3.98	3.99	3.99	3.99	3.99
	41	TC	14.38	14.37	14.51	14.66	15.20	15.53	15.53	15.67	15.61	15.61	15.61	15.61	16.70	16.70	16.70	16.70
		S/T	0.73	0.83	0.92	0.99	0.58	0.67	0.76	0.85	0.51	0.60	0.68	0.77	0.35	0.43	0.51	0.59
		PI	4.02	4.02	4.02	4.02	4.02	4.02	4.02	4.02	4.02	4.02	4.02	4.02	4.02	4.02	4.02	4.02
	50	TC	14.29	14.28	14.43	14.57	15.13	15.45	15.45	15.60	15.54	15.54	15.54	15.54	16.66	16.66	16.66	16.66
		S/T	0.73	0.83	0.92	0.99	0.58	0.67	0.76	0.85	0.51	0.60	0.68	0.77	0.36	0.44	0.51	0.59
		PI	4.09	4.09	4.09	4.09	4.08	4.08	4.08	4.08	4.08	4.08	4.08	4.08	4.07	4.07	4.07	4.07
	59	TC	14.18	14.16	14.31	14.45	15.02	15.35	15.35	15.50	15.45	15.45	15.45	15.45	16.59	16.59	16.59	16.59
		S/T	0.74	0.84	0.93	1.00	0.59	0.68	0.77	0.86	0.52	0.61	0.69	0.78	0.36	0.44	0.52	0.60
		PI	4.19	4.19	4.19	4.19	4.17	4.17	4.17	4.17	4.17	4.17	4.17	4.17	4.16	4.16	4.16	4.16
	68	TC	14.02	14.00	14.15	14.29	14.87	14.87	14.87	14.87	15.30	15.30	15.30	15.30	16.44	16.44	16.44	16.44
		S/T	0.74	0.84	0.93	1.00	0.59	0.68	0.77	0.86	0.52	0.61	0.69	0.78	0.36	0.44	0.52	0.60
		PI	4.33	4.33	4.33	4.33	4.31	4.31	4.31	4.31	4.30	4.30	4.30	4.30	4.29	4.29	4.29	4.29
77	TC	13.37	13.37	13.52	13.66	14.21	14.21	14.21	14.21	14.64	14.64	14.64	14.64	15.73	15.73	15.73	15.73	
	S/T	0.75	0.85	0.95	1.00	0.59	0.69	0.78	0.88	0.52	0.61	0.70	0.79	0.35	0.44	0.52	0.61	
	PI	4.78	4.78	4.78	4.78	4.77	4.77	4.77	4.77	4.77	4.77	4.77	4.77	4.78	4.78	4.78	4.78	
86	TC	12.74	12.74	12.86	12.97	13.55	13.55	13.55	13.69	13.95	13.95	13.95	13.95	15.04	15.04	15.04	15.04	
	S/T	0.76	0.87	0.97	1.00	0.60	0.70	0.80	0.89	0.52	0.62	0.72	0.81	0.35	0.44	0.53	0.62	
	PI	5.23	5.23	5.23	5.23	5.24	5.24	5.24	5.24	5.25	5.25	5.25	5.25	5.27	5.27	5.27	5.27	
95	TC	12.11	12.23	12.34	12.45	12.89	12.89	12.89	13.00	13.29	13.29	13.29	13.29	14.32	14.32	14.32	14.32	
	S/T	0.78	0.88	0.99	1.00	0.61	0.71	0.81	0.91	0.53	0.63	0.72	0.83	0.35	0.44	0.53	0.63	
	PI	5.72	5.72	5.72	5.72	5.74	5.74	5.74	5.74	5.75	5.75	5.75	5.75	5.79	5.79	5.79	5.79	
104	TC	11.29	11.40	11.51	11.63	12.01	12.01	12.01	12.13	12.40	12.40	12.40	12.40	13.40	13.40	13.40	13.40	
	S/T	0.80	0.92	1.00	1.00	0.62	0.73	0.85	0.96	0.53	0.64	0.76	0.87	0.34	0.44	0.54	0.65	
	PI	6.31	6.31	6.31	6.31	6.34	6.34	6.34	6.34	6.35	6.35	6.35	6.35	6.39	6.39	6.39	6.39	
114.8	TC	10.45	10.56	10.68	10.79	11.13	11.13	11.13	11.25	11.50	11.50	11.50	11.50	12.47	12.47	12.47	12.47	
	S/T	0.82	0.94	1.00	1.00	0.63	0.75	0.86	0.98	0.54	0.65	0.77	0.88	0.34	0.44	0.55	0.66	
	PI	7.01	7.01	7.01	7.01	7.05	7.05	7.05	7.05	7.07	7.07	7.07	7.07	7.12	7.12	7.12	7.12	
122	TC	9.80	9.88	9.97	10.08	10.48	10.48	10.59	10.71	10.82	10.82	10.82	10.93	11.73	11.73	11.73	11.73	
	S/T	0.84	0.97	1.00	1.00	0.64	0.76	0.89	1.00	0.54	0.67	0.79	0.91	0.33	0.45	0.56	0.67	
	PI	7.60	7.60	7.60	7.60	7.63	7.63	7.63	7.63	7.65	7.65	7.65	7.65	7.71	7.71	7.71	7.71	
1295	5	TC	15.02	15.02	15.17	15.33	15.79	15.79	15.94	16.17	16.17	16.17	16.17	16.17	17.19	17.19	17.19	17.19
		S/T	0.73	0.83	0.98	1.00	0.58	0.67	0.76	0.85	0.50	0.60	0.69	0.78	0.34	0.42	0.51	0.59
		PI	4.07	4.07	4.07	4.07	4.06	4.06	4.06	4.06	4.05	4.05	4.05	4.05	4.05	4.05	4.05	4.05
	14	TC	14.94	14.94	15.08	15.23	15.71	15.71	15.71	15.85	16.09	16.09	16.09	16.09	17.13	17.13	17.13	17.13
		S/T	0.74	0.83	0.99	1.00	0.58	0.67	0.77	0.85	0.50	0.60	0.69	0.79	0.34	0.43	0.51	0.59
		PI	4.05	4.05	4.05	4.05	4.05	4.05	4.05	4.05	4.05	4.05	4.05	4.05	4.05	4.05	4.05	4.05
	23	TC	14.85	14.85	14.99	15.14	15.65	15.65	15.65	15.79	16.03	16.03	16.03	16.03	17.09	17.09	17.09	17.09
		S/T	0.74	0.84	0.99	1.00	0.59	0.67	0.77	0.86	0.51	0.60	0.69	0.79	0.34	0.43	0.52	0.59
		PI	4.05	4.05	4.05	4.05	4.04	4.04	4.04	4.04	4.05	4.05	4.05	4.05	4.06	4.06	4.06	4.06
	32	TC	14.77	14.77	14.92	15.07	15.59	15.59	15.59	15.73	15.99	15.99	15.99	15.99	17.07	17.07	17.07	17.07
		S/T	0.74	0.84	1.00	1.00	0.59	0.68	0.77	0.86	0.51	0.61	0.70	0.79	0.34	0.43	0.52	0.60
		PI	4.06	4.06	4.06	4.06	4.06	4.06	4.06	4.06	4.06	4.06	4.06	4.06	4.07	4.07	4.07	4.07
	41	TC	14.70	14.70	14.84	14.99	15.53	15.53	15.53	15.67	15.94	15.94	15.94	15.94	17.06	17.06	17.06	17.06
		S/T	0.75	0.85	1.00	1.00	0.59	0.68	0.78	0.87	0.51	0.61	0.70	0.80	0.34	0.43	0.52	0.60
		PI	4.10	4.10	4.10	4.10	4.09	4.09	4.09	4.09	4.09	4.09	4.09	4.09	4.10	4.10	4.10	4.10
	50	TC	14.61	14.61	14.75	14.90	15.45	15.45	15.45	15.60	15.87	15.87	15.87	15.87	17.01	17.01	17.01	17.01
		S/T	0.75	0.85	1.00	1.00	0.59	0.68	0.78	0.87	0.51	0.61	0.70	0.80	0.35	0.44	0.52	0.60
		PI	4.17	4.17	4.17	4.17	4.16	4.16	4.16	4.16	4.15	4.15	4.15	4.15	4.15	4.15	4.15	4.15
	59	TC	14.49	14.49	14.63	14.78	15.35	15.35	15.35	15.50	15.77	15.77	15.77	15.77	16.94	16.94	16.94	16.94
		S/T	0.76	0.86	0.96	1.00	0.60	0.69	0.79	0.88	0.52	0.62	0.71	0.81	0.35	0.44	0.53	0.61
		PI	4.27	4.27	4.27	4.27	4.25	4.25	4.25	4.25	4.25	4.25	4.25	4.25	4.24	4.24	4.24	4.24
	68	TC	14.33	14.33	14.47	14.61	15.19	15.19	15.19	15.33	15.62	15.62	15.62	15.62	16.80	16.80	16.80	16.80
		S/T	0.76	0.86	0.96	1.00	0.60	0.69	0.79	0.88	0.52	0.62	0.71	0.81	0.35	0.44	0.53	0.61
		PI	4.42	4.42	4.42	4.42	4.40	4.40	4.4									

1413	5	TC	15.33	15.33	15.48	15.63	16.12	16.12	16.12	16.27	16.53	16.53	16.53	16.53	17.54	17.54	17.54	17.54
		S/T	0.74	0.85	1.00	1.00	0.59	0.69	0.78	0.98	0.51	0.61	0.70	0.80	0.34	0.42	0.51	0.61
		PI	4.15	4.15	4.15	4.15	4.14	4.14	4.14	4.14	4.13	4.13	4.13	4.13	4.13	4.13	4.13	4.13
	14	TC	15.23	15.23	15.38	15.53	16.03	16.03	16.03	16.18	16.45	16.45	16.45	16.45	17.48	17.48	17.48	17.48
		S/T	0.75	0.85	1.00	1.00	0.59	0.69	0.79	0.98	0.51	0.61	0.71	0.81	0.34	0.43	0.51	0.61
		PI	4.13	4.13	4.13	4.13	4.13	4.13	4.13	4.13	4.13	4.13	4.13	4.13	4.13	4.13	4.13	4.13
	23	TC	15.14	15.14	15.29	15.44	15.97	15.97	15.97	16.12	16.38	16.38	16.38	16.38	17.44	17.44	17.44	17.44
		S/T	0.75	0.86	1.00	1.00	0.59	0.69	0.79	0.99	0.52	0.61	0.71	0.81	0.34	0.43	0.52	0.61
		PI	4.13	4.13	4.13	4.13	4.12	4.12	4.12	4.12	4.13	4.13	4.13	4.13	4.14	4.14	4.14	4.14
	32	TC	15.07	15.07	15.22	15.36	15.91	15.91	15.91	16.06	16.34	16.34	16.34	16.34	17.42	17.42	17.42	17.42
		S/T	0.75	0.86	1.00	1.00	0.60	0.70	0.79	0.99	0.52	0.62	0.72	0.81	0.34	0.43	0.52	0.62
		PI	4.14	4.14	4.14	4.14	4.14	4.14	4.14	4.14	4.14	4.14	4.14	4.14	4.15	4.15	4.15	4.15
	41	TC	14.99	14.99	15.14	15.29	15.85	15.85	15.85	16.00	16.29	16.29	16.29	16.29	17.41	17.41	17.41	17.41
		S/T	0.76	0.87	1.00	1.00	0.60	0.70	0.80	1.00	0.52	0.62	0.72	0.82	0.34	0.43	0.52	0.62
		PI	4.18	4.18	4.18	4.18	4.18	4.18	4.18	4.18	4.18	4.18	4.18	4.18	4.18	4.18	4.18	4.18
	50	TC	14.90	14.90	15.05	15.19	15.78	15.78	15.78	15.92	16.22	16.22	16.22	16.22	17.36	17.36	17.36	17.36
		S/T	0.76	0.87	1.00	1.00	0.60	0.70	0.80	1.00	0.52	0.62	0.72	0.82	0.35	0.44	0.52	0.62
		PI	4.25	4.25	4.25	4.25	4.24	4.24	4.24	4.24	4.24	4.24	4.24	4.24	4.24	4.24	4.24	4.24
	59	TC	14.78	14.78	14.93	15.07	15.67	15.67	15.67	15.81	16.12	16.12	16.12	16.12	17.29	17.29	17.29	17.29
		S/T	0.77	0.88	0.99	1.00	0.61	0.71	0.81	0.91	0.53	0.63	0.73	0.83	0.35	0.44	0.53	0.63
PI		4.35	4.35	4.35	4.35	4.34	4.34	4.34	4.34	4.33	4.33	4.33	4.33	4.33	4.33	4.33	4.33	4.33
68	TC	14.61	14.61	14.76	14.90	15.50	15.50	15.50	15.65	15.96	15.96	15.96	15.96	17.14	17.14	17.14	17.14	
	S/T	0.77	0.88	0.99	1.00	0.61	0.71	0.81	0.91	0.53	0.63	0.73	0.83	0.35	0.44	0.53	0.63	
	PI	4.51	4.51	4.51	4.51	4.49	4.49	4.49	4.49	4.48	4.48	4.48	4.48	4.46	4.46	4.46	4.46	4.46
77	TC	13.95	14.10	14.24	14.38	14.81	14.81	14.81	14.96	15.25	15.25	15.25	15.25	16.42	16.42	16.42	16.42	
	S/T	0.79	0.90	1.00	1.00	0.61	0.72	0.83	0.93	0.53	0.64	0.74	0.85	0.34	0.44	0.54	0.64	
	PI	4.97	4.97	4.97	4.97	4.96	4.96	4.96	4.96	4.96	4.96	4.96	4.96	4.96	4.97	4.97	4.97	4.97
86	TC	13.29	13.44	13.58	13.72	14.13	14.13	14.13	14.27	14.56	14.56	14.56	14.56	15.68	15.68	15.68	15.68	
	S/T	0.80	0.92	1.00	1.00	0.62	0.73	0.85	0.96	0.53	0.64	0.76	0.87	0.34	0.44	0.54	0.65	
	PI	5.44	5.44	5.44	5.44	5.45	5.45	5.45	5.45	5.46	5.46	5.46	5.46	5.48	5.48	5.48	5.48	5.48
95	TC	12.63	12.75	12.86	12.98	13.44	13.44	13.44	13.58	13.87	13.87	13.87	14.07	14.21	14.96	14.96	14.96	14.96
	S/T	0.82	0.94	1.00	1.00	0.63	0.75	0.87	0.98	0.54	0.65	0.77	0.88	0.34	0.44	0.55	0.66	
	PI	5.95	5.95	5.95	5.95	5.97	5.97	5.97	5.97	5.98	5.98	5.98	5.99	5.98	6.02	6.02	6.02	6.02
104	TC	11.91	12.02	12.14	12.25	12.69	12.69	12.74	12.87	13.09	13.09	13.20	13.33	14.15	14.15	14.15	14.15	14.15
	S/T	0.85	0.99	1.00	1.00	0.64	0.78	0.90	1.00	0.55	0.68	0.80	0.93	0.33	0.45	0.57	0.90	
	PI	6.56	6.56	6.56	6.56	6.59	6.59	6.59	6.59	6.60	6.60	6.61	6.60	6.65	6.65	6.65	6.65	6.65
114.8	TC	11.01	11.13	11.24	11.36	11.76	11.76	11.88	11.99	12.14	12.14	12.14	12.14	12.25	13.14	13.14	13.14	13.14
	S/T	0.87	1.00	1.00	1.00	0.65	0.79	0.92	1.00	0.55	0.69	0.82	0.95	0.33	0.45	0.57	0.92	
	PI	7.30	7.30	7.30	7.30	7.33	7.33	7.33	7.33	7.35	7.35	7.35	7.35	7.41	7.41	7.41	7.41	7.41
122	TC	10.35	10.47	10.58	10.70	11.07	11.07	11.19	11.30	11.42	11.42	11.42	11.53	12.39	12.39	12.39	12.39	12.39
	S/T	0.89	1.00	1.00	1.00	0.67	0.81	0.95	1.00	0.56	0.70	0.85	0.98	0.33	0.46	0.59	0.97	
	PI	7.90	7.90	7.90	7.90	7.94	7.94	7.94	7.94	7.96	7.96	7.96	7.96	8.02	8.02	8.02	8.02	8.02

TC:Total Cooling Capacity (kW)

S/T:Sensible Cooling Capacity Ratio

PI:Power Input(kW)

Note: The table shows the case where the operation frequency of a compressor is fixed.

8.2 Heating

MVB-24HWFN1-M+MOD31-24HFN1-MTOW								[SI_Unit]	
INDOOR AIRFLOW (CFM)	HEATING PERFORMANCE AT INDOOR DRY BULB TEMPERATURE								
	OUTDOOR DB(°F)	TC:TOTAL CAPACITY IN KILOWATTS (KW)				PI:TOTAL POWER IN KILOWATTS (KW)			
		Indoor Conditions (DB °F)				Indoor Conditions (DB °F)			
		60.8	68.0	71.6	75.2	60.8	68.0	71.6	75.2
589	5.0	4.69	4.61	4.59	4.56	2.37	2.45	2.42	2.42
	17.0	5.01	4.93	4.90	4.87	2.53	2.61	2.58	2.59
	19.4	5.24	5.16	5.13	5.11	2.69	2.78	2.74	2.75
	22.0	5.48	5.39	5.36	5.34	2.62	2.65	2.67	2.68
	27.0	5.71	5.62	5.60	5.57	2.51	2.53	2.55	2.56
	32.0	5.86	5.77	5.74	5.71	2.40	2.42	2.43	2.44
	37.0	6.23	6.15	6.12	6.06	2.30	2.32	2.33	2.34
	42.0	6.84	6.76	6.70	6.67	2.21	2.22	2.23	2.24
	44.6	7.48	7.39	7.19	7.13	2.18	2.14	2.19	2.20
	52.0	7.88	7.79	7.74	7.68	2.03	2.03	2.03	2.03
	57.0	8.29	8.17	8.11	8.05	1.93	1.92	1.92	1.92
	62.0	8.66	8.55	8.49	8.43	1.82	1.82	1.81	1.81
64.4	8.84	8.72	8.66	8.61	1.78	1.77	1.76	1.76	
765	5.0	4.79	4.72	4.69	4.67	2.39	2.47	2.43	2.45
	17.0	5.12	5.04	5.01	4.98	2.55	2.64	2.60	2.61
	19.4	5.36	5.28	5.25	5.22	2.71	2.80	2.76	2.78
	22.0	5.60	5.51	5.48	5.45	2.65	2.68	2.69	2.71
	27.0	5.83	5.74	5.71	5.68	2.53	2.56	2.57	2.58
	32.0	5.97	5.91	5.86	5.83	2.42	2.44	2.45	2.46
	37.0	6.38	6.29	6.23	6.20	2.32	2.34	2.35	2.36
	42.0	6.99	6.87	6.84	6.78	2.23	2.24	2.25	2.25
	44.6	7.66	7.53	7.33	7.27	2.20	2.15	2.21	2.22
	52.0	8.05	7.94	7.88	7.82	2.05	2.05	2.05	2.05
	57.0	8.43	8.32	8.26	8.20	1.94	1.94	1.94	1.93
	62.0	8.81	8.69	8.63	8.58	1.84	1.83	1.83	1.82
64.4	9.01	8.87	8.81	8.75	1.79	1.78	1.77	1.77	
883	5.0	4.82	4.77	4.72	4.70	2.42	2.50	2.46	2.48
	17.0	5.15	5.09	5.04	5.01	2.58	2.67	2.62	2.64
	19.4	5.39	5.34	5.28	5.25	2.74	2.84	2.79	2.81
	22.0	5.65	5.60	5.54	5.51	2.68	2.71	2.72	2.74
	27.0	5.89	5.83	5.77	5.74	2.56	2.59	2.60	2.61
	32.0	6.06	5.97	5.91	5.89	2.45	2.47	2.48	2.49
	37.0	6.44	6.35	6.32	6.26	2.35	2.37	2.37	2.38
	42.0	7.05	6.96	6.93	6.87	2.26	2.27	2.27	2.28
	44.6	7.72	7.62	7.42	7.36	2.22	2.18	2.24	2.24
	52.0	8.14	8.03	7.97	7.91	2.07	2.07	2.07	2.07
	57.0	8.52	8.40	8.34	8.29	1.96	1.96	1.96	1.95
	62.0	8.92	8.81	8.75	8.66	1.86	1.85	1.84	1.84
64.4	9.10	8.98	8.92	8.87	1.81	1.79	1.79	1.78	

Note: The table shows the case where the operation frequency of a compressor is fixed.

MVB-24HWFN1-M+MOD01-23HFN1-MTOW								[SI_Unit]	
INDOOR AIRFLOW (CFM)	HEATING PERFORMANCE AT INDOOR DRY BULB TEMPERATURE								
	OUTDOOR DB(°F)	TC:TOTAL CAPACITY IN KILOWATTS (KW)				PI:TOTAL POWER IN KILOWATTS (KW)			
		Indoor Conditions (DB °F)				Indoor Conditions (DB °F)			
		60.8	68.0	71.6	75.2	60.8	68.0	71.6	75.2
589	5.0	6.61	6.53	6.50	6.48	3.36	3.48	3.38	3.38
	17.0	7.06	6.97	6.95	6.92	3.59	3.72	3.60	3.60
	19.4	7.39	7.31	7.28	7.25	3.81	3.95	3.83	3.83
	22.0	7.39	7.31	7.28	7.25	3.67	3.67	3.68	3.68
	27.0	7.39	7.31	7.28	7.22	3.41	3.40	3.40	3.40
	32.0	7.31	7.22	7.16	7.13	3.16	3.14	3.14	3.13
	37.0	7.48	7.36	7.33	7.28	2.92	2.90	2.88	2.87
	42.0	7.88	7.77	7.74	7.68	2.69	2.65	2.63	2.61
	44.6	8.36	8.24	8.15	8.09	2.58	2.40	2.52	2.49
	52.0	8.53	8.41	8.35	8.30	2.22	2.16	2.12	2.09
	57.0	8.70	8.59	8.53	8.47	1.97	1.90	1.86	1.83
	62.0	8.88	8.73	8.67	8.62	1.73	1.65	1.61	1.56
64.4	8.96	8.82	8.76	8.67	1.62	1.52	1.48	1.43	
765	5.0	6.72	6.66	6.61	6.59	3.39	3.52	3.40	3.41
	17.0	7.17	7.12	7.06	7.03	3.61	3.75	3.63	3.64
	19.4	7.51	7.45	7.40	7.37	3.84	3.98	3.86	3.87
	22.0	7.54	7.48	7.42	7.39	3.70	3.71	3.71	3.72
	27.0	7.54	7.45	7.42	7.39	3.44	3.43	3.43	3.43
	32.0	7.45	7.36	7.33	7.28	3.19	3.17	3.16	3.16
	37.0	7.62	7.54	7.48	7.42	2.95	2.92	2.91	2.89
	42.0	8.03	7.94	7.88	7.83	2.71	2.67	2.65	2.63
	44.6	8.50	8.41	8.33	8.27	2.61	2.42	2.54	2.51
	52.0	8.73	8.62	8.56	8.50	2.24	2.17	2.14	2.11
	57.0	8.91	8.76	8.70	8.64	1.99	1.91	1.87	1.84
	62.0	9.05	8.93	8.85	8.79	1.75	1.66	1.62	1.57
64.4	9.14	8.99	8.93	8.88	1.63	1.53	1.49	1.44	
883	5.0	6.82	6.74	6.71	6.69	3.42	3.55	3.44	3.45
	17.0	7.28	7.19	7.17	7.14	3.65	3.79	3.67	3.68
	19.4	7.62	7.54	7.51	7.48	3.88	4.03	3.90	3.91
	22.0	7.62	7.54	7.51	7.48	3.74	3.75	3.75	3.75
	27.0	7.62	7.54	7.51	7.45	3.48	3.47	3.47	3.46
	32.0	7.54	7.45	7.39	7.36	3.22	3.20	3.19	3.19
	37.0	7.71	7.59	7.57	7.51	2.98	2.95	2.94	2.92
	42.0	8.12	8.03	7.97	7.91	2.74	2.70	2.68	2.66
	44.6	8.59	8.50	8.41	8.35	2.63	2.44	2.56	2.54
	52.0	8.82	8.70	8.64	8.59	2.25	2.19	2.16	2.13
	57.0	8.99	8.85	8.79	8.73	2.00	1.92	1.89	1.85
	62.0	9.14	9.02	8.93	8.88	1.76	1.67	1.63	1.58
64.4	9.22	9.08	9.02	8.96	1.64	1.54	1.50	1.45	

Note: The table shows the case where the operation frequency of a compressor is fixed.

MVB-24HWFN1-M+MOD30-24HFN1-MTOW								[SI_Unit]	
INDOOR AIRFLOW (CFM)	HEATING PERFORMANCE AT INDOOR DRY BULB TEMPERATURE								
	OUTDOOR DB(°F)	TC:TOTAL CAPACITY IN KILOWATTS (KW)				PI:TOTAL POWER IN KILOWATTS (KW)			
		Indoor Conditions (DB °F)				Indoor Conditions (DB °F)			
		60.8	68.0	71.6	75.2	60.8	68.0	71.6	75.2
589	5.0	5.95	5.90	5.84	5.82	3.05	3.17	3.09	3.10
	17.0	6.35	6.29	6.24	6.21	3.26	3.38	3.30	3.31
	19.4	6.65	6.59	6.54	6.51	3.46	3.59	3.50	3.51
	22.0	6.80	6.74	6.68	6.65	3.35	3.37	3.38	3.39
	27.0	6.91	6.83	6.80	6.77	3.16	3.17	3.17	3.18
	32.0	6.94	6.86	6.83	6.77	2.96	2.96	2.96	2.96
	37.0	7.23	7.15	7.09	7.06	2.78	2.77	2.77	2.76
	42.0	7.79	7.67	7.61	7.58	2.60	2.58	2.58	2.57
	44.6	8.36	8.24	8.09	8.04	2.52	2.40	2.49	2.48
	52.0	8.67	8.56	8.50	8.44	2.24	2.21	2.19	2.17
	57.0	8.93	8.82	8.76	8.70	2.05	2.01	1.99	1.97
	62.0	9.22	9.11	9.02	8.96	1.86	1.82	1.79	1.77
64.4	9.37	9.22	9.17	9.11	1.78	1.72	1.70	1.67	
765	5.0	6.07	6.02	5.97	5.95	3.09	3.20	3.12	3.13
	17.0	6.49	6.43	6.38	6.35	3.30	3.42	3.33	3.34
	19.4	6.80	6.74	6.68	6.65	3.50	3.63	3.54	3.55
	22.0	6.94	6.89	6.83	6.80	3.39	3.41	3.42	3.43
	27.0	7.06	6.97	6.94	6.91	3.19	3.20	3.21	3.21
	32.0	7.12	7.03	6.97	6.91	2.99	2.99	2.99	2.99
	37.0	7.41	7.29	7.26	7.20	2.81	2.80	2.79	2.79
	42.0	7.93	7.84	7.79	7.73	2.63	2.61	2.60	2.59
	44.6	8.51	8.41	8.27	8.21	2.55	2.42	2.51	2.50
	52.0	8.85	8.73	8.67	8.62	2.26	2.22	2.21	2.19
	57.0	9.14	9.02	8.93	8.88	2.07	2.02	2.00	1.98
	62.0	9.43	9.28	9.22	9.17	1.87	1.83	1.80	1.78
64.4	9.57	9.43	9.37	9.28	1.79	1.73	1.70	1.67	
883	5.0	6.13	6.08	6.03	6.00	3.12	3.24	3.16	3.17
	17.0	6.54	6.49	6.43	6.41	3.33	3.45	3.37	3.38
	19.4	6.85	6.80	6.74	6.71	3.54	3.67	3.58	3.59
	22.0	7.00	6.94	6.89	6.86	3.43	3.44	3.45	3.46
	27.0	7.15	7.06	7.00	6.97	3.22	3.23	3.23	3.24
	32.0	7.18	7.09	7.03	7.00	3.02	3.02	3.02	3.02
	37.0	7.47	7.38	7.32	7.26	2.83	2.82	2.82	2.82
	42.0	8.02	7.90	7.87	7.81	2.65	2.63	2.62	2.61
	44.6	8.62	8.50	8.33	8.30	2.57	2.44	2.53	2.52
	52.0	8.93	8.82	8.76	8.70	2.28	2.24	2.22	2.21
	57.0	9.22	9.11	9.05	8.96	2.08	2.04	2.01	1.99
	62.0	9.51	9.40	9.31	9.25	1.89	1.83	1.81	1.79
64.4	9.66	9.54	9.46	9.40	1.80	1.74	1.71	1.68	

Note: The table shows the case where the operation frequency of a compressor is fixed.

MVB-24HWFN1-M+MOD30-24HFN1-MU0W								[SI_Unit]	
INDOOR AIRFLOW (CFM)	HEATING PERFORMANCE AT INDOOR DRY BULB TEMPERATURE								
	OUTDOOR DB(°F)	TC:TOTAL CAPACITY IN KILOWATTS (KW)				PI:TOTAL POWER IN KILOWATTS (KW)			
		Indoor Conditions (DB °F)				Indoor Conditions (DB °F)			
		60.8	68.0	71.6	75.2	60.8	68.0	71.6	75.2
589	5.0	6.80	6.75	6.72	6.69	2.90	3.01	2.91	2.92
	17.0	7.26	7.20	7.18	7.15	3.09	3.21	3.10	3.11
	19.4	7.61	7.55	7.52	7.49	3.29	3.41	3.30	3.31
	22.0	7.49	7.43	7.40	7.37	3.17	3.17	3.17	3.18
	27.0	7.37	7.31	7.29	7.23	2.94	2.94	2.93	2.93
	32.0	7.17	7.11	7.05	7.02	2.72	2.70	2.70	2.69
	37.0	7.23	7.14	7.08	7.05	2.51	2.49	2.48	2.48
	42.0	7.49	7.37	7.34	7.29	2.32	2.29	2.27	2.25
	44.6	7.80	7.68	7.65	7.59	2.22	2.06	2.16	2.14
	52.0	7.86	7.74	7.68	7.62	1.90	1.85	1.82	1.79
	57.0	7.88	7.77	7.71	7.65	1.69	1.62	1.59	1.57
	62.0	7.91	7.80	7.74	7.65	1.48	1.41	1.37	1.34
64.4	7.91	7.80	7.74	7.68	1.38	1.30	1.26	1.22	
765	5.0	6.97	6.89	6.86	6.83	2.93	3.04	2.94	2.94
	17.0	7.44	7.35	7.33	7.30	3.12	3.24	3.14	3.14
	19.4	7.79	7.70	7.67	7.65	3.32	3.44	3.34	3.34
	22.0	7.66	7.58	7.55	7.52	3.20	3.20	3.21	3.21
	27.0	7.52	7.46	7.43	7.37	2.97	2.97	2.96	2.96
	32.0	7.31	7.26	7.20	7.17	2.74	2.73	2.72	2.72
	37.0	7.37	7.26	7.23	7.17	2.54	2.51	2.50	2.49
	42.0	7.63	7.52	7.49	7.43	2.34	2.31	2.29	2.27
	44.6	7.95	7.83	7.80	7.74	2.24	2.08	2.18	2.16
	52.0	8.00	7.88	7.83	7.77	1.92	1.87	1.84	1.81
	57.0	8.03	7.91	7.86	7.80	1.70	1.64	1.61	1.58
	62.0	8.06	7.91	7.86	7.80	1.50	1.42	1.39	1.35
64.4	8.06	7.94	7.88	7.80	1.39	1.31	1.27	1.23	
883	5.0	7.01	6.95	6.93	6.90	2.95	3.07	2.97	2.98
	17.0	7.48	7.43	7.40	7.37	3.15	3.27	3.17	3.18
	19.4	7.84	7.78	7.75	7.72	3.35	3.48	3.37	3.38
	22.0	7.72	7.66	7.63	7.60	3.23	3.24	3.24	3.24
	27.0	7.60	7.52	7.49	7.46	3.00	3.00	2.99	2.99
	32.0	7.40	7.31	7.29	7.23	2.77	2.76	2.75	2.74
	37.0	7.43	7.34	7.31	7.26	2.56	2.54	2.53	2.51
	42.0	7.72	7.60	7.55	7.52	2.37	2.33	2.31	2.30
	44.6	8.03	7.91	7.88	7.83	2.26	2.10	2.20	2.18
	52.0	8.09	7.97	7.91	7.86	1.94	1.88	1.86	1.83
	57.0	8.12	8.00	7.94	7.88	1.72	1.65	1.62	1.59
	62.0	8.15	8.03	7.97	7.88	1.51	1.44	1.40	1.36
64.4	8.17	8.03	7.97	7.91	1.41	1.33	1.29	1.25	

Note: The table shows the case where the operation frequency of a compressor is fixed.

MVB-36HWFN1-M								[SI_Unit]	
INDOOR AIRFLOW (CFM)	HEATING PERFORMANCE AT INDOOR DRY BULB TEMPERATURE								
	OUTDOOR DB(°F)	TC:TOTAL CAPACITY IN KILOWATTS (KW)				PI:TOTAL POWER IN KILOWATTS (KW)			
		Indoor Conditions (DB °F)				Indoor Conditions (DB °F)			
		60.8	68.0	71.6	75.2	60.8	68.0	71.6	75.2
824	5.0	6.64	6.56	6.51	6.46	2.50	2.57	2.64	2.68
	17.0	7.09	7.01	6.95	6.90	2.67	2.75	2.81	2.86
	19.4	7.42	7.34	7.29	7.23	2.84	2.92	2.99	3.04
	22.0	7.86	7.78	7.72	7.66	2.87	2.97	3.02	3.07
	27.0	8.27	8.18	8.12	8.07	2.94	3.05	3.10	3.16
	32.0	8.59	8.47	8.41	8.36	3.02	3.13	3.17	3.23
	37.0	9.23	9.08	9.02	8.97	3.12	3.23	3.29	3.34
	42.0	10.18	10.07	9.98	9.92	3.22	3.34	3.40	3.46
	44.6	11.21	11.08	10.76	10.68	3.29	3.49	3.47	3.53
	52.0	11.89	11.75	11.66	11.60	3.42	3.55	3.62	3.68
	57.0	12.53	12.39	12.30	12.21	3.51	3.65	3.71	3.78
	62.0	13.17	13.00	12.91	12.82	3.61	3.74	3.81	3.88
64.4	13.49	13.32	13.20	13.11	3.65	3.79	3.86	3.93	
1001	5.0	6.80	6.70	6.68	6.63	2.52	2.60	2.66	2.71
	17.0	7.26	7.16	7.13	7.08	2.69	2.77	2.84	2.89
	19.4	7.61	7.50	7.47	7.41	2.86	2.94	3.02	3.07
	22.0	8.04	7.92	7.89	7.83	2.90	3.00	3.05	3.10
	27.0	8.44	8.36	8.30	8.24	2.97	3.08	3.13	3.18
	32.0	8.76	8.65	8.59	8.53	3.05	3.16	3.20	3.26
	37.0	9.43	9.28	9.23	9.17	3.16	3.26	3.32	3.38
	42.0	10.42	10.27	10.18	10.13	3.26	3.38	3.44	3.50
	44.6	11.47	11.31	10.97	10.91	3.32	3.53	3.51	3.57
	52.0	12.16	11.98	11.92	11.84	3.46	3.59	3.66	3.72
	57.0	12.79	12.65	12.56	12.47	3.56	3.69	3.76	3.82
	62.0	13.46	13.29	13.17	13.08	3.65	3.79	3.86	3.93
64.4	13.78	13.58	13.49	13.40	3.69	3.83	3.91	3.98	
1177	5.0	6.87	6.77	6.74	6.70	2.56	2.63	2.69	2.73
	17.0	7.33	7.23	7.20	7.15	2.73	2.80	2.87	2.91
	19.4	7.68	7.57	7.54	7.49	2.90	2.98	3.05	3.10
	22.0	8.12	8.01	7.98	7.92	2.93	3.03	3.09	3.14
	27.0	8.53	8.44	8.38	8.33	3.00	3.11	3.16	3.21
	32.0	8.85	8.73	8.67	8.62	3.08	3.18	3.24	3.30
	37.0	9.52	9.37	9.31	9.26	3.18	3.30	3.36	3.42
	42.0	10.50	10.36	10.30	10.24	3.30	3.42	3.48	3.54
	44.6	11.59	11.43	11.08	11.02	3.36	3.57	3.55	3.61
	52.0	12.27	12.13	12.04	11.95	3.50	3.63	3.70	3.76
	57.0	12.94	12.76	12.68	12.59	3.60	3.73	3.80	3.87
	62.0	13.61	13.40	13.32	13.23	3.69	3.83	3.90	3.97
64.4	13.90	13.72	13.64	13.52	3.74	3.88	3.95	4.02	

Note: The table shows the case where the operation frequency of a compressor is fixed.

MVB-48HWFN1-M								[SI_Unit]	
INDOOR AIRFLOW (CFM)	HEATING PERFORMANCE AT INDOOR DRY BULB TEMPERATURE								
	OUTDOOR DB(°F)	TC:TOTAL CAPACITY IN KILOWATTS (KW)				PI:TOTAL POWER IN KILOWATTS (KW)			
		Indoor Conditions (DB °F)				Indoor Conditions (DB °F)			
		60.8	68.0	71.6	75.2	60.8	68.0	71.6	75.2
1177	5.0	9.57	9.47	9.39	9.34	3.87	3.98	4.12	4.20
	17.0	10.21	10.11	10.03	9.98	4.13	4.24	4.39	4.48
	19.4	10.70	10.59	10.51	10.45	4.39	4.51	4.66	4.76
	22.0	11.29	11.17	11.08	11.03	4.49	4.67	4.77	4.86
	27.0	11.84	11.69	11.61	11.55	4.68	4.89	4.99	5.09
	32.0	12.22	12.07	11.98	11.90	4.89	5.11	5.22	5.32
	37.0	13.09	12.91	12.83	12.74	5.16	5.39	5.50	5.62
	42.0	14.42	14.22	14.13	14.04	5.43	5.66	5.78	5.90
	44.6	15.85	15.63	15.19	15.08	5.59	6.01	5.94	6.06
	52.0	16.76	16.53	16.41	16.29	5.93	6.19	6.32	6.45
	57.0	17.60	17.37	17.25	17.13	6.17	6.44	6.58	6.71
	62.0	18.47	18.21	18.09	17.98	6.41	6.69	6.83	6.96
64.4	18.87	18.61	18.50	18.38	6.52	6.81	6.95	7.09	
1295	5.0	9.78	9.66	9.61	9.53	3.91	4.02	4.16	4.24
	17.0	10.44	10.31	10.26	10.18	4.18	4.28	4.44	4.52
	19.4	10.94	10.80	10.75	10.66	4.44	4.55	4.71	4.80
	22.0	11.52	11.37	11.32	11.23	4.53	4.72	4.81	4.91
	27.0	12.07	11.93	11.84	11.78	4.73	4.94	5.04	5.15
	32.0	12.48	12.30	12.22	12.13	4.94	5.16	5.27	5.38
	37.0	13.35	13.17	13.09	13.00	5.22	5.44	5.56	5.66
	42.0	14.71	14.51	14.42	14.31	5.49	5.72	5.84	5.96
	44.6	16.17	15.95	15.48	15.39	5.64	6.07	6.00	6.13
	52.0	17.11	16.87	16.76	16.64	5.99	6.26	6.39	6.52
	57.0	17.98	17.74	17.60	17.48	6.23	6.51	6.65	6.78
	62.0	18.84	18.58	18.47	18.35	6.48	6.76	6.89	7.04
64.4	19.28	19.02	18.87	18.76	6.59	6.87	7.02	7.16	
1413	5.0	9.88	9.75	9.70	9.63	3.95	4.05	4.20	4.28
	17.0	10.55	10.41	10.36	10.28	4.21	4.32	4.48	4.57
	19.4	11.05	10.91	10.86	10.77	4.48	4.60	4.76	4.85
	22.0	11.64	11.49	11.43	11.35	4.58	4.76	4.86	4.96
	27.0	12.22	12.04	11.98	11.90	4.78	4.99	5.09	5.20
	32.0	12.62	12.45	12.36	12.27	4.99	5.21	5.32	5.43
	37.0	13.49	13.32	13.23	13.14	5.27	5.50	5.61	5.72
	42.0	14.89	14.68	14.57	14.48	5.54	5.77	5.89	6.02
	44.6	16.34	16.12	15.66	15.54	5.70	6.13	6.06	6.19
	52.0	17.28	17.05	16.93	16.82	6.05	6.31	6.45	6.58
	57.0	18.18	17.92	17.80	17.69	6.29	6.57	6.71	6.85
	62.0	19.05	18.79	18.67	18.55	6.54	6.83	6.96	7.10
64.4	19.48	19.22	19.08	18.96	6.65	6.94	7.08	7.23	

Note: The table shows the case where the operation frequency of a compressor is fixed. Note:

9. Noise Criterion Curves

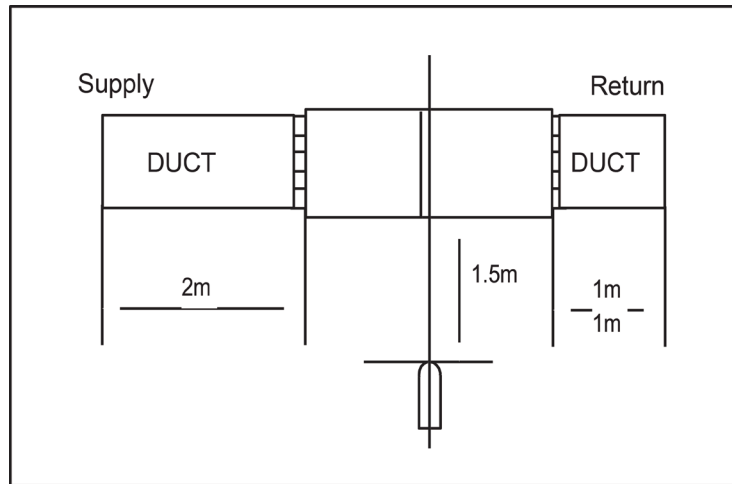

Notes:

- Sound measured at 1.5m away from the center of the unit.
- Data is valid at free field condition
- Data is valid at nominal operation condition
- Reference acoustic pressure $OdB = 20\mu Pa$
- Sound level will vary depending on a range of factors such as the construction -(acoustic absorption coefficient) of particular room in which the equipment is installed.
- The operating conditions are assumed to be standard.

MVB-24HWFN1-M

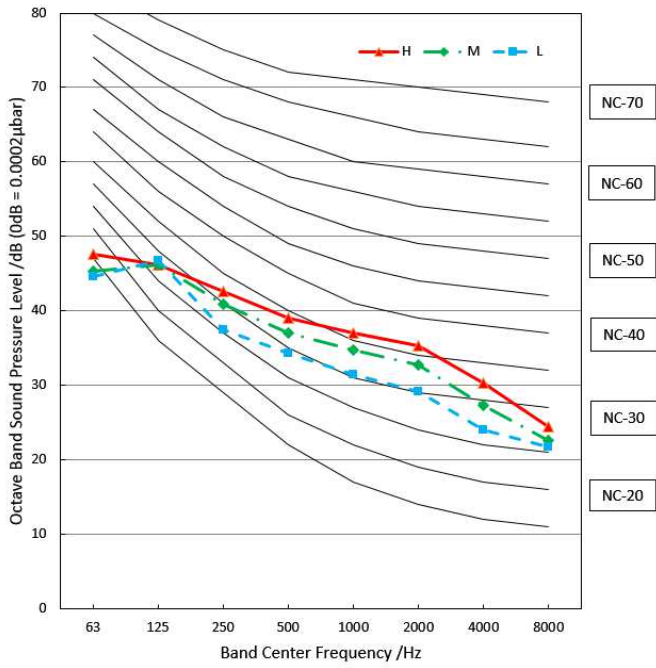

MVB-36HWFN1-M

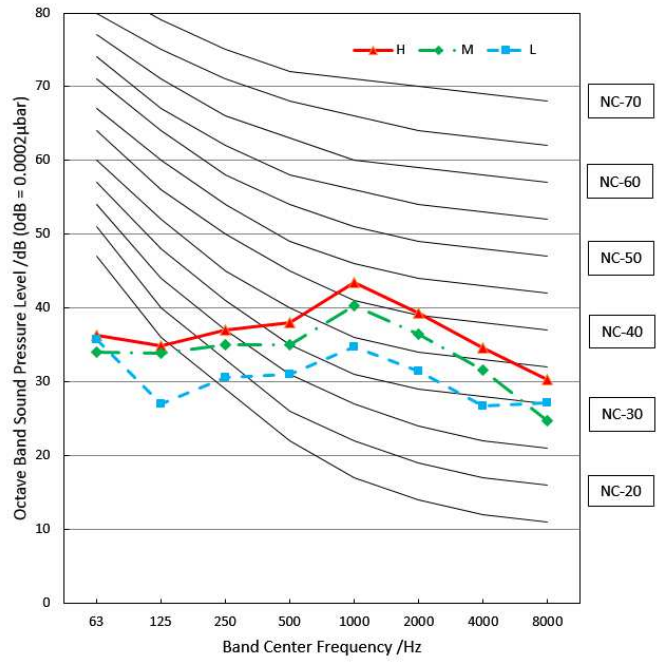

MVB-48HWFN1-M

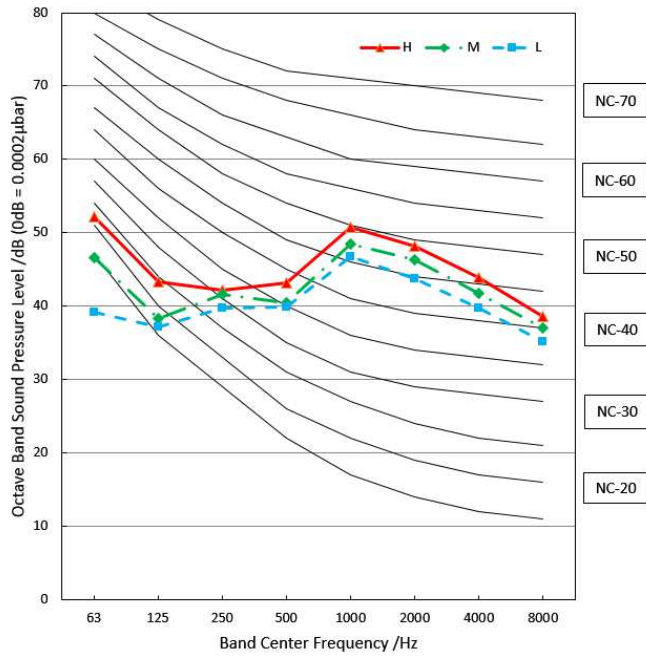

10. Electrical Characteristics

Capacity (Btu/h)		24K	36K	48K
Power (indoor)	Phase	1	1	1
	Frequency And Volt	208/230V,60Hz		
Power (Outdoor)	Phase	1	1	1
	Frequency And Volt	208/230V,60Hz		
Input circuit fuse	Indoor unit(A)	10	10	10
Outdoor unit Power line	Line quantity	3	3	3
	Line diameter(AWG)	14/2.5mm ²	12/4.0mm ²	10/6.0mm ²
Outdoor-indoor Signal line	Line quantity	/	2	2
	Line diameter(AWG)		24/0.2mm ²	24/0.2mm ²
Thermostat Signal line	Line quantity	5	5	5
	Line diameter(AWG)	18//1.0mm ²	18//1.0mm ²	18//1.0mm ²
Indoor-outdoor Connction line	Line quantity	4	3	3
	Line diameter(AWG)	14/2.5mm ²	14/2.5mm ²	14/2.5mm ²

11. Electrical Wiring Diagrams

IDU Capacity (Btu/h)	IDU Wiring Diagram
24K	16023000009727
36K~48K	16023000009726

Abbreviation	Paraphrase
Y/G	Yellow-Green Conductor
CAP	Indoor Fan Capacitor
DC FAN	Direct Current FAN
PUMP	PUMP
L	LIVE
N	NEUTRAL
TO CCM Comm.Bus	Central Controller
T1	Indoor Room Temperature
T2	Coil Temperature of Indoor Heat Exchanger

Indoor unit wiring diagram: 16023000009726

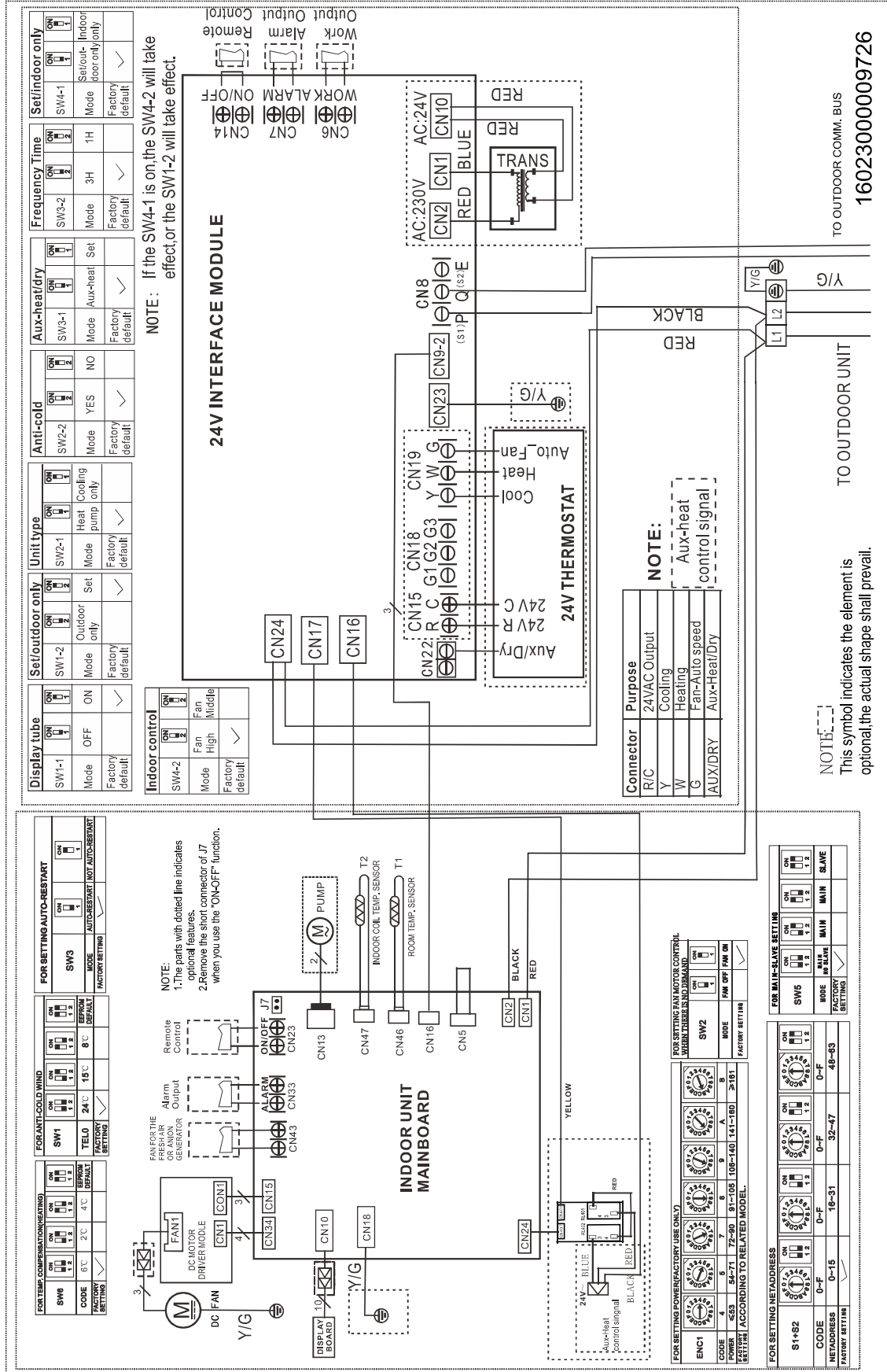

10.1 Some connectors introduce:

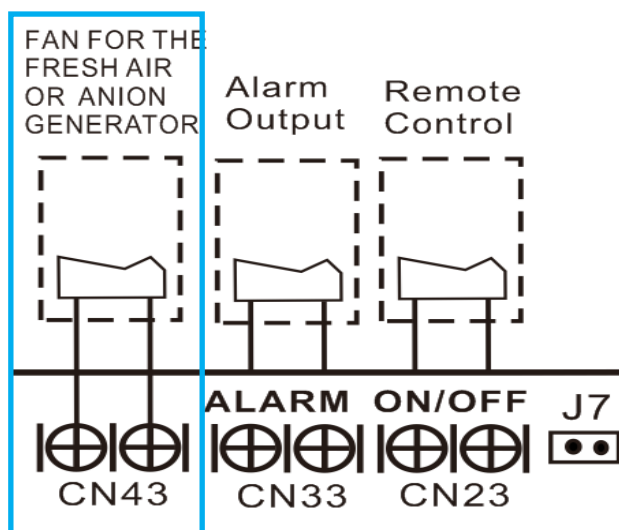

A. For new fresh motor terminal port (also for Anion generator) CN43:

1. Connect the fan motor to the port, no need care L/N of the motor;
2. The output voltage is the power supply;
3. The fresh motor can not exceed 200W or 1A, follow the smaller one;
4. The new fresh motor will be worked when the indoor fan motor work ;when the indoor fan motor stops , the new fresh motor would be stopped;
5. When the unit enters force cooling mode or capacity testing mode , the fresh motor isn't work.

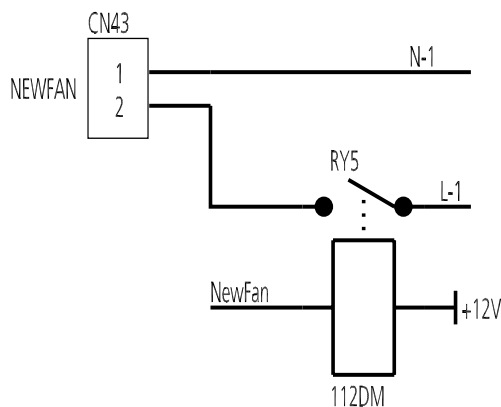

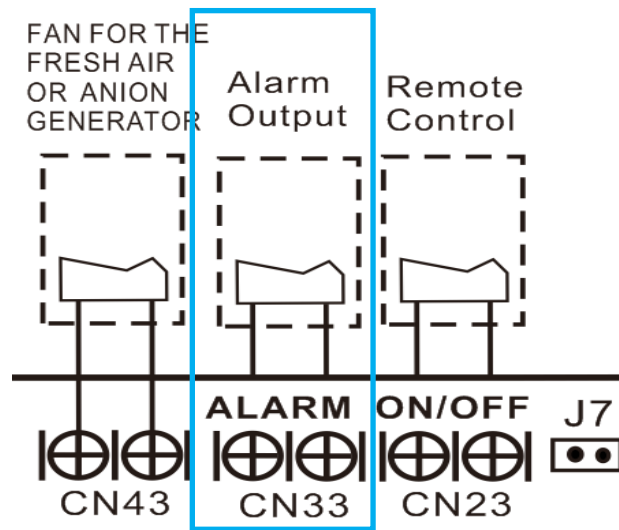

B For ALARM terminal port CN33

1. Provide the terminal port to connect ALARM, but no voltage of the terminal port, the power from the ALARM system (not from the unit);
2. Although design voltage can support higher voltage, but we strongly ask you connect the power less than 24V, current less than 0.5A;
3. When the unit occurs the problem, the relay would be closed, then ALARM works.

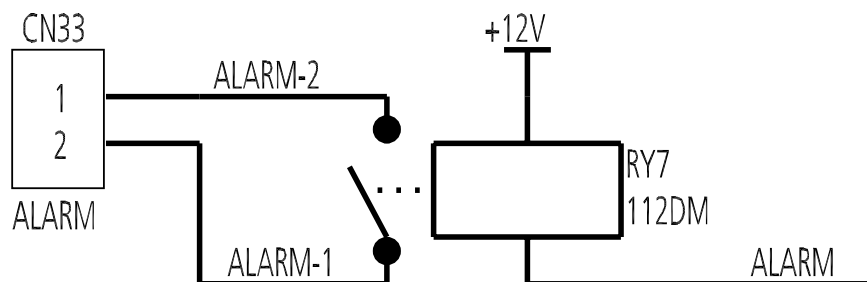

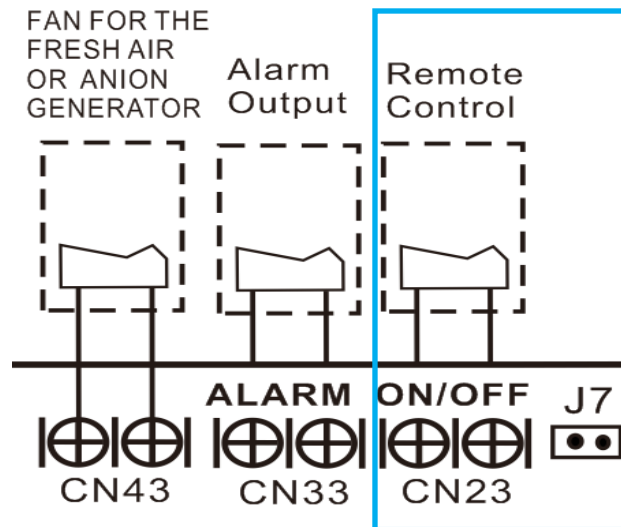

C. For remote control (ON-OFF) terminal port CN23 and short connector of J7

1. Remove the short connector of J7 when you use ON-OFF function;
2. When remote switch off (OPEN); the unit would be off;
3. When remote switch on (CLOSE); the unit would be on;
4. When close/open the remote switch, the unit would be responded the demand within 2 seconds;
5. When the remote switch on, you can use remote controller/ wire controller to select the mode what you want; when the remote switch off, the unit would not respond the demand from remote controller/wire controller.

when the remote switch off, but the remote controller/wire controller are on, CP code would be shown on the display board.

6. The voltage of the port is 12V DC, design Max. current is 5mA.

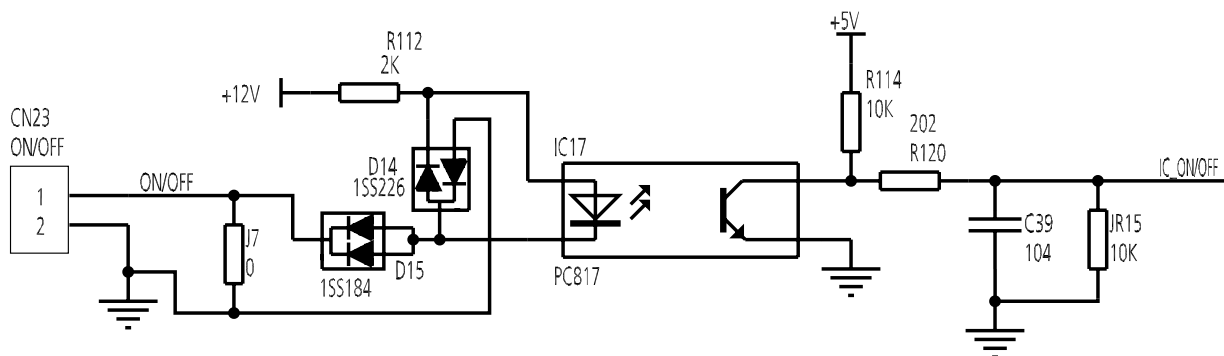

10.2 Micro-Switch Introduce:

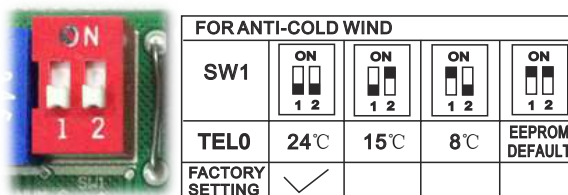

A. Micro-switch SW1 is for selection of indoor fan stop temperature (TELO) when it is in anti-cold wind action in heating mode.

Range: 24°C, 15°C, 8°C, according to EEPROM setting (reserved for special customizing).

For 24K:

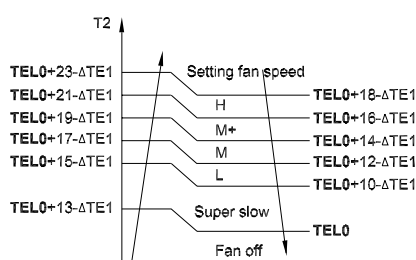

For 36K~48K:

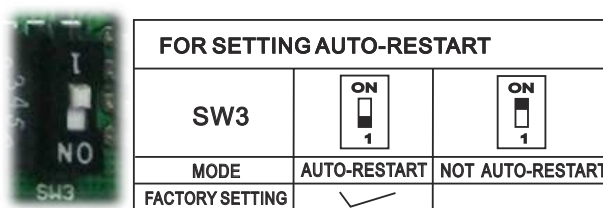
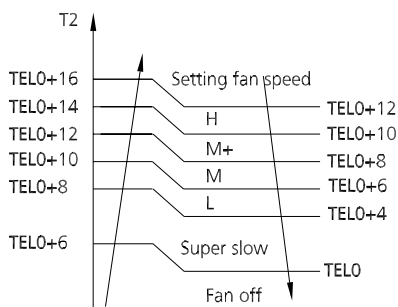

B. Micro-switch SW3 is for selection of auto-restart function.

Range: Active, inactive

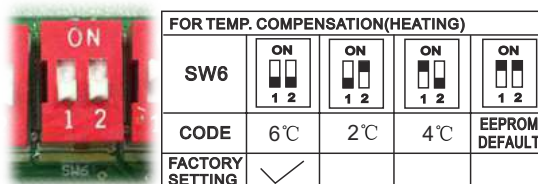

C. Micro-switch SW6 is for selection of temperature compensation in heating mode. This helps to reduce the real temperature difference between ceiling and floor so that the unit could run properly. If the height of installation is lower, smaller value could be chosen.

Range: 6°C, 4°C, 2°C, E function (reserved for special customizing)

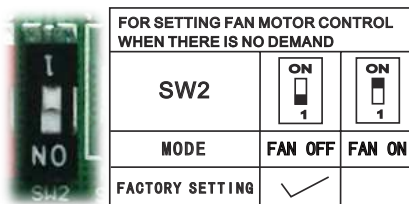

D. Micro-switch SW2 is for selection of indoor FAN ACTION if room temperature reaches the set point and the compressor stops.

Range: OFF (in 127s), Keep running.

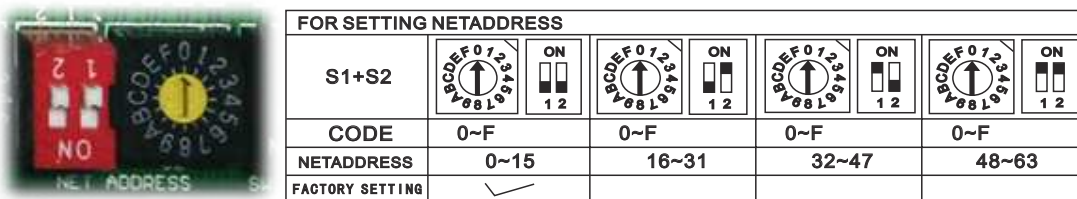

E. Micro-switch S1 and dial-switch S2 are for address setting when you want to control this unit by a central controller.

Range: 00-63.

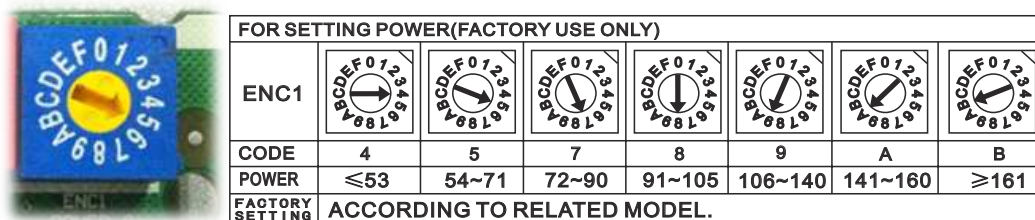

F. Dial-switch ENC1(for 24K): The indoor PCB is universal designed for whole series units from 18K to 68K. This ENC1 setting will tell the main program what size the unit is.

NOTE: Usually there is glue on it because the switch position cannot be changed at random unless you want to use this PCB as a spare part to use in another unit. Then you have to select the right position to match the size of the unit.

“53” means 5.3kW (18K), “105” means 10.5kW(36K), and so on.

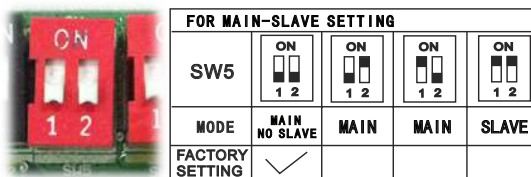

G. Micro-switch SW5(for 24K) is for setting the master or slave unit when the unit is in twin connection.

Range: Master no slave (Normal 1 drive 1 connection), Master (2 positions without difference), Slave

Outdoor Unit

Contents

1.	Dimensional Drawings	2
2.	Service Place.....	8
3.	Capacity Correction Factor for Height Difference	9
4.	Noise Criterion Curves.....	12
5.	Refrigerant Cycle Diagrams	14
6.	Electrical Wiring Diagrams.....	17

1. Dimensional Drawings

Please check the corresponding dimensional drawing according to the panel plate.

ODU Model	Panel Plate
24k	D30
36k	D30
48k	E30

Panel Plate B30

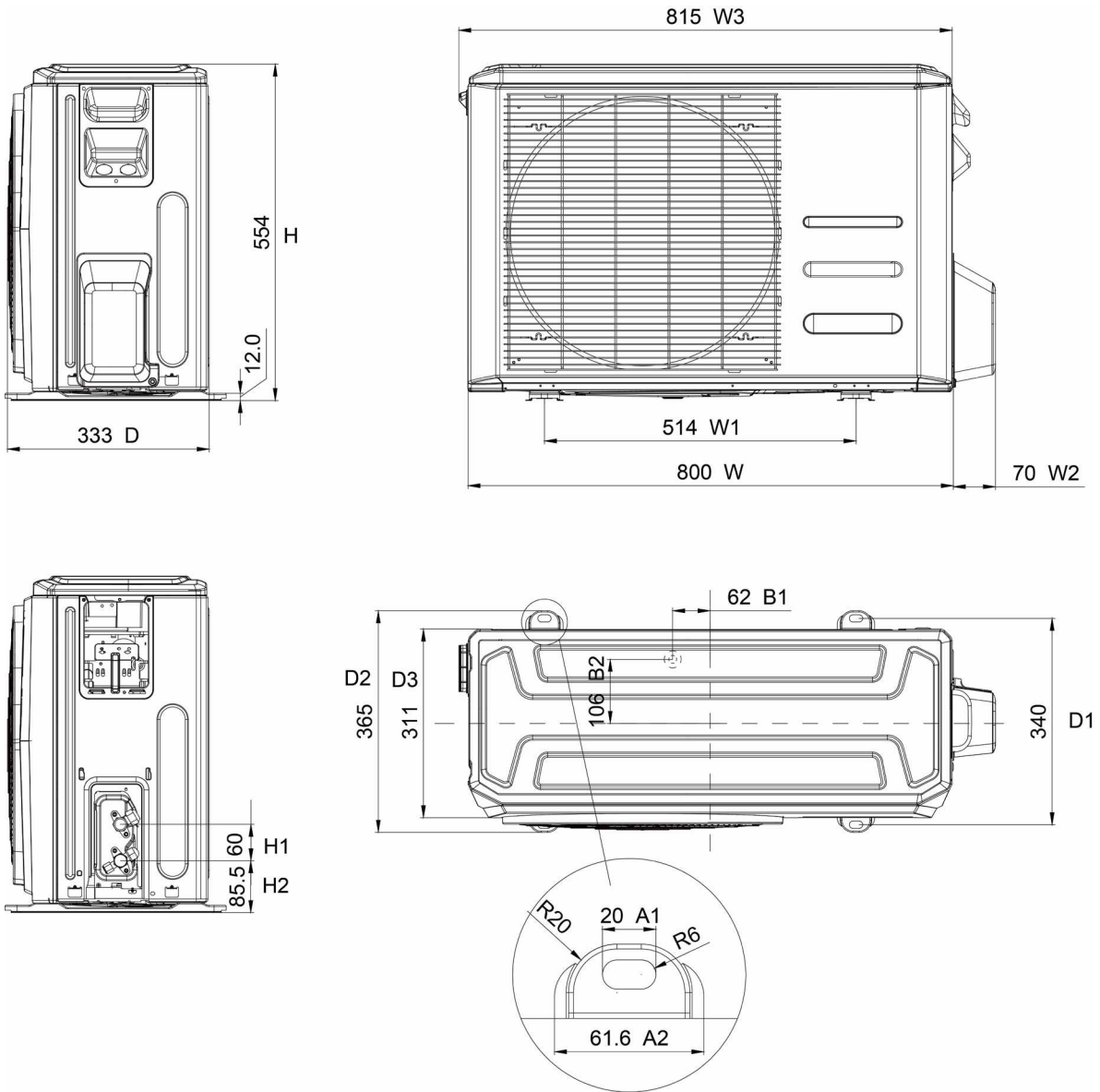

Panel Plate BA30

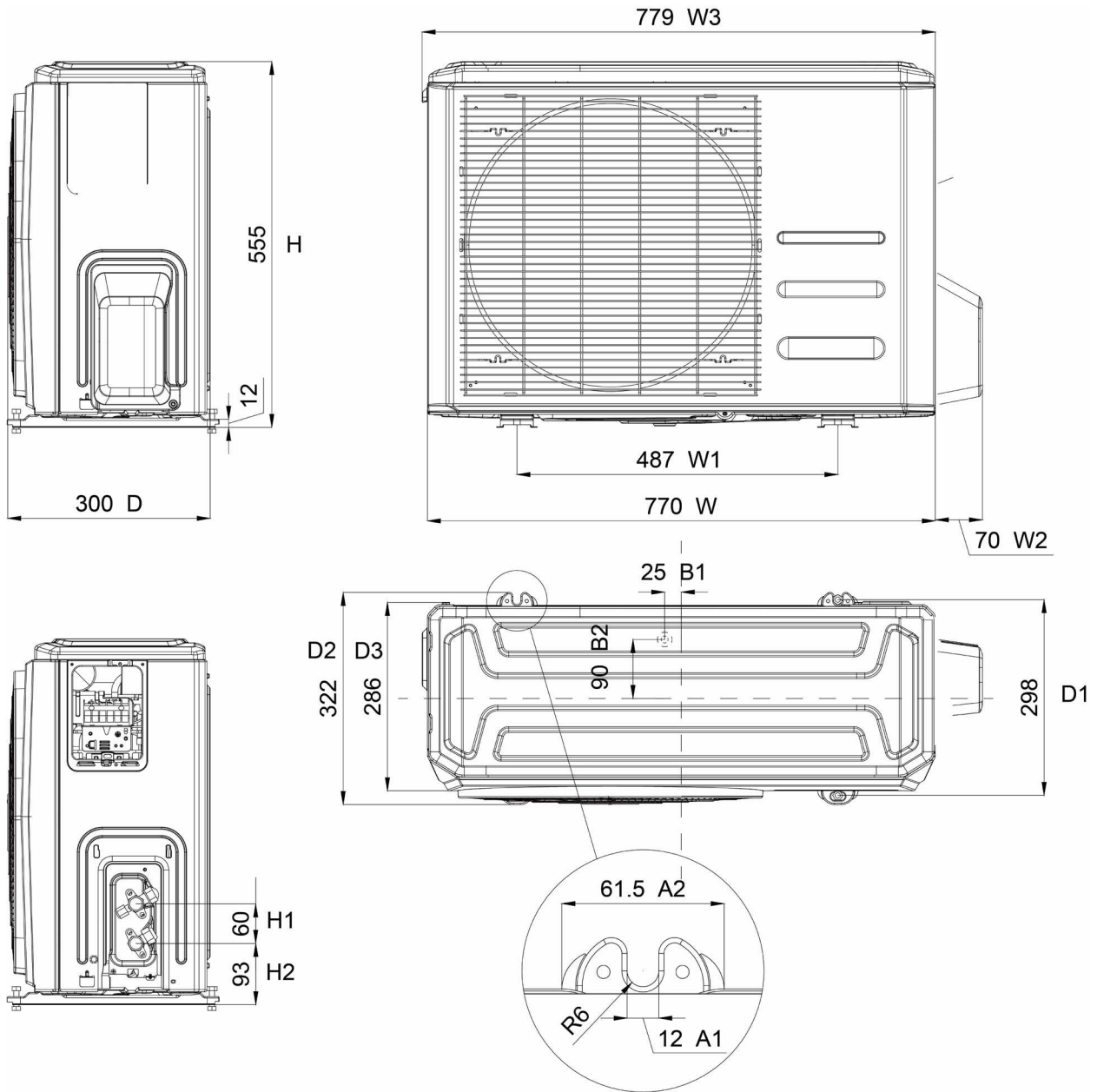

Panel Plate CA30

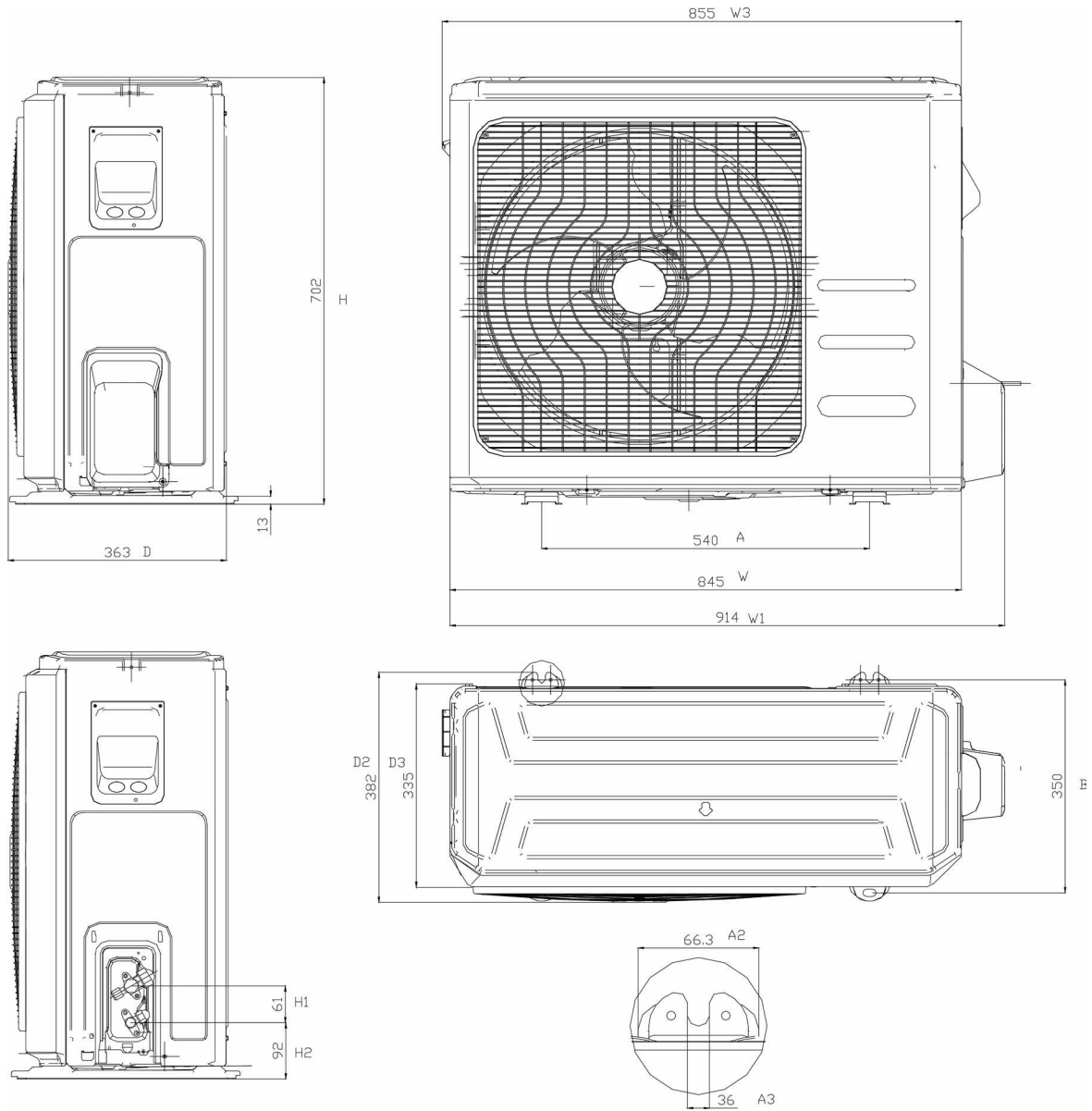

Panel Plate D30

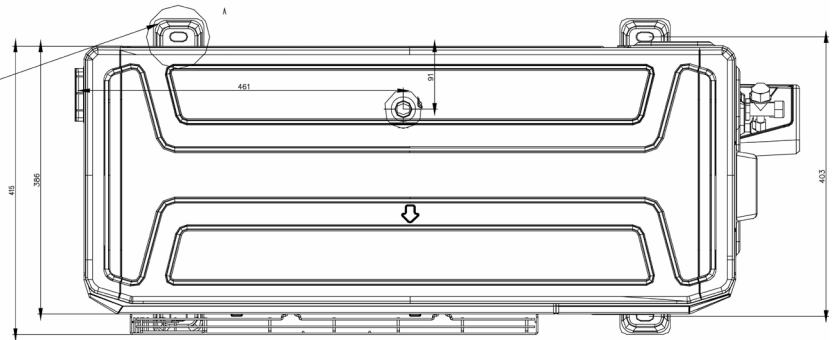
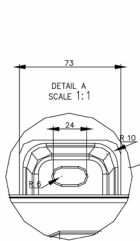
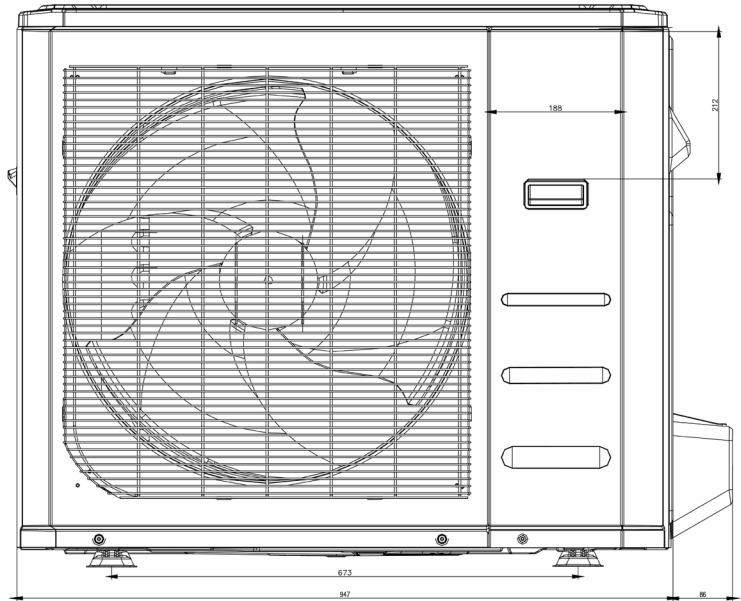
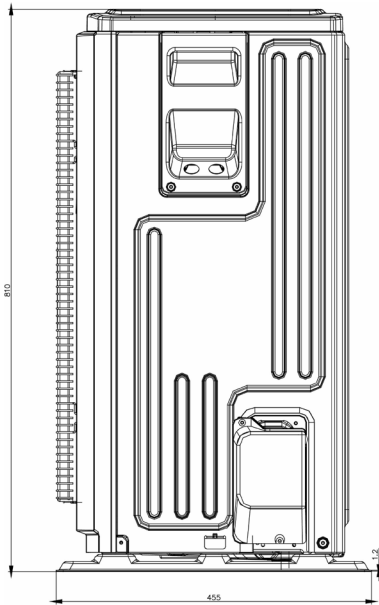

Panel Plate E30

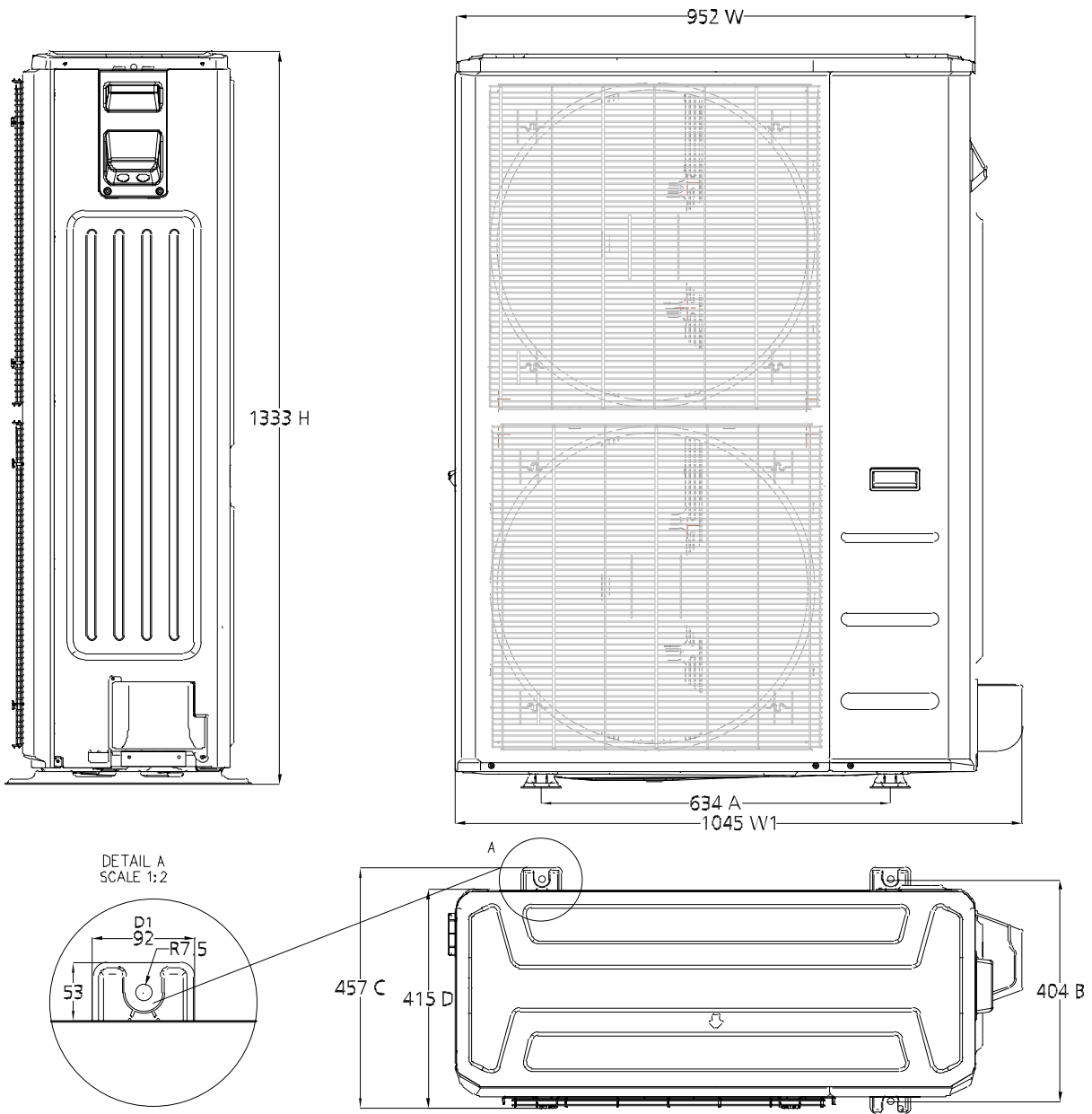

2. Service Place

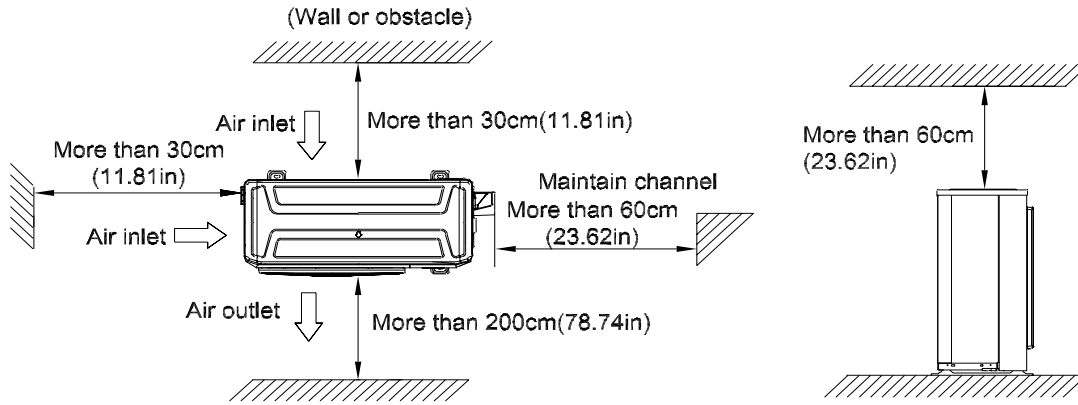

3. Capacity Correction Factor for Height Difference

Capacity (Btu/h)	24k		Pipe Length (m)					
Cooling			5	10	20	30	40	50
Height difference H (m)	Indoor Upper than Outdoor	25	/	/	/	0.917	0.898	0.879
		20	/	/	0.946	0.926	0.907	0.887
		10	/	0.975	0.955	0.936	0.916	0.896
		5	0.995	0.985	0.965	0.945	0.925	0.905
	0		1.000	0.990	0.970	0.950	0.930	0.910
	Outdoor Upper than Indoor	-5	1.000	0.990	0.970	0.950	0.930	0.910
		-10	/	0.990	0.970	0.950	0.930	0.910
		-20	/	/	0.970	0.950	0.930	0.910
		-25	/	/	/	0.950	0.930	0.910
	Heating			5	10	20	30	40
Height difference H (m)	Indoor Upper than Outdoor	25	/	/	/	0.984	0.978	0.972
		20	/	/	0.991	0.984	0.978	0.972
		10	/	0.997	0.991	0.984	0.978	0.972
		5	1.000	0.997	0.991	0.984	0.978	0.972
	0		1.000	0.997	0.991	0.984	0.978	0.972
	Outdoor Upper than Indoor	-5	0.992	0.989	0.983	0.977	0.970	0.964
		-10	/	0.981	0.975	0.969	0.963	0.957
		-20	/	/	0.967	0.961	0.955	0.949
		-25	/	/	/	0.953	0.947	0.941

Capacity (Btu/h)	36k		Pipe Length (m)					
Cooling			5	15	25	35	50	65
Height difference H (m)	Indoor Upper than Outdoor	30				0.889	0.850	0.812
		20			0.924	0.898	0.859	0.820
		10		0.959	0.933	0.907	0.868	0.828
		5	0.995	0.969	0.942	0.916	0.876	0.837
		0	1.000	0.974	0.947	0.921	0.881	0.841
	Outdoor Upper than Indoor	-5	1.000	0.974	0.947	0.921	0.881	0.841
		-10		0.974	0.947	0.921	0.881	0.841
		-20			0.947	0.921	0.881	0.841
		-30				0.921	0.881	0.841
	Heating			5	15	25	35	50
Height difference H (m)	Indoor Upper than Outdoor	30				0.964	0.945	0.927
		20			0.976	0.964	0.945	0.927
		10		0.988	0.976	0.964	0.945	0.927
		5	1.000	0.988	0.976	0.964	0.945	0.927
		0	1.000	0.988	0.976	0.964	0.945	0.927
	Outdoor Upper than Indoor	-5	0.992	0.980	0.968	0.956	0.938	0.920
		-10		0.972	0.960	0.948	0.930	0.912
		-20			0.952	0.941	0.923	0.905
		-30				0.933	0.915	0.898

Capacity (Btu/h)	48k		Pipe Length (m)					
Cooling			5	15	25	35	50	65
Height difference H (m)	Indoor Upper than Outdoor	30				0.884	0.843	0.802
		20			0.920	0.893	0.852	0.810
		10		0.957	0.930	0.902	0.860	0.819
		5	0.995	0.967	0.939	0.911	0.869	0.827
		0	1.000	0.972	0.944	0.916	0.873	0.831
	Outdoor Upper than Indoor	-5	1.000	0.972	0.944	0.916	0.873	0.831
		-10		0.972	0.944	0.916	0.873	0.831
		-20			0.944	0.916	0.873	0.831
		-30				0.916	0.873	0.831
	Heating			5	15	25	35	50
Height difference H (m)	Indoor Upper than Outdoor	30				0.958	0.936	0.915
		20			0.972	0.958	0.936	0.915
		10		0.986	0.972	0.958	0.936	0.915
		5	1.000	0.986	0.972	0.958	0.936	0.915
		0	1.000	0.986	0.972	0.958	0.936	0.915
	Outdoor Upper than Indoor	-5	0.992	0.978	0.964	0.950	0.929	0.908
		-10		0.970	0.956	0.942	0.921	0.900
		-20			0.949	0.935	0.914	0.893
		-30				0.927	0.907	0.886

4. Noise Criterion Curves

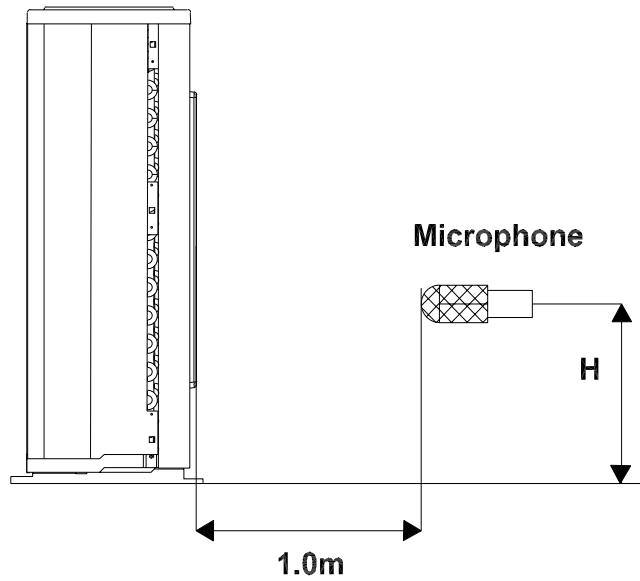

Note: $H = 0.5 \times \text{height of outdoor unit}$

Notes:

- Sound measured at 1.0m away from the center of the unit.
- Data is valid at free field condition
- Data is valid at nominal operation condition
- Reference acoustic pressure $OdB = 20\mu Pa$
- Sound level will vary depending on arrangement of factors such as the construction (acoustic absorption coefficient) of particular room in which the equipment is installed.
- The operating conditions are assumed to be standard.

MOD31-24HFN1-MT0W

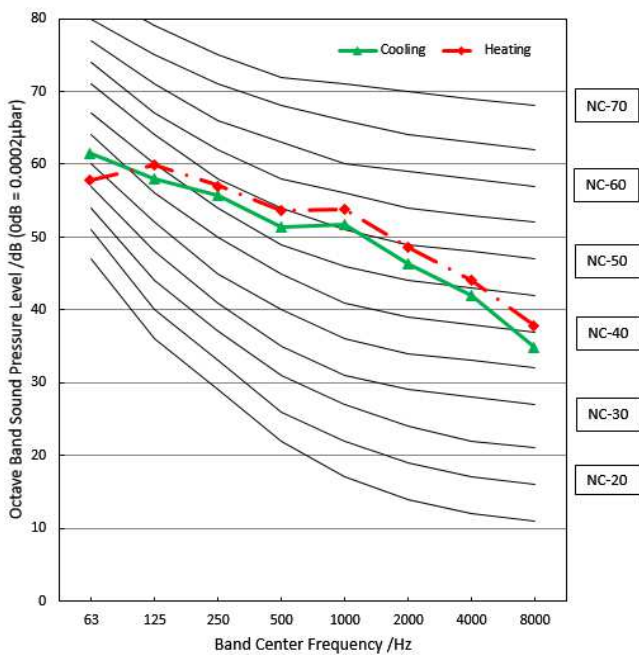

MOD01-23HFN1-MT0W

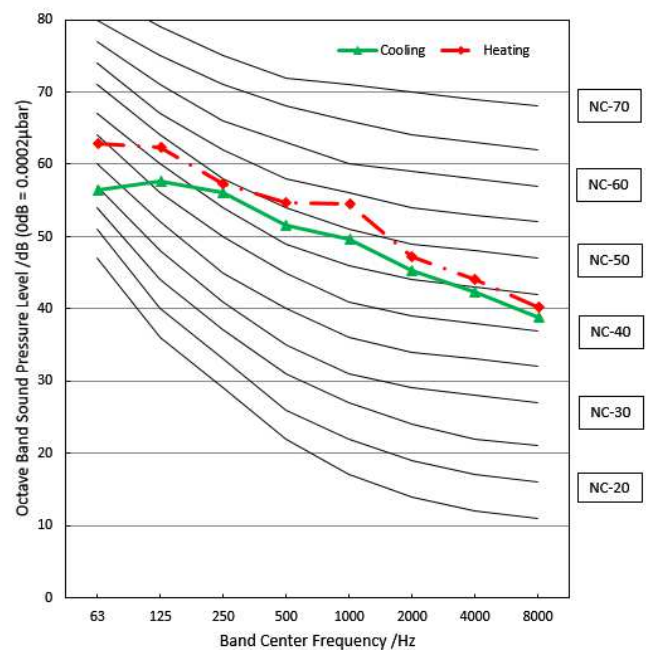

MOD30-24HFN1-MT0W

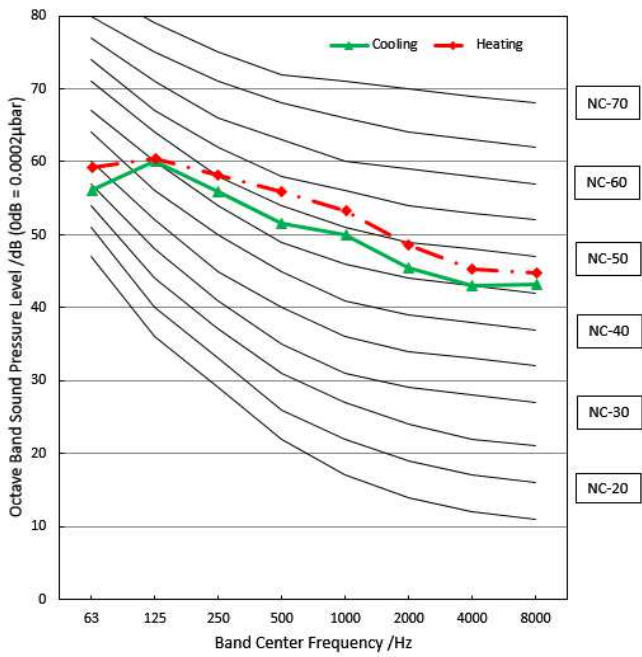

MOD30-24HFN1-MU0W

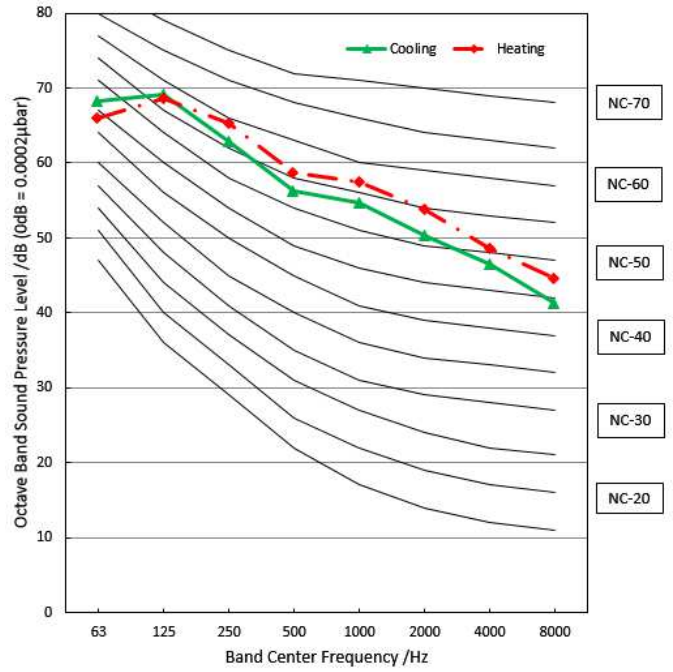

MOD30U-36HFN1-M

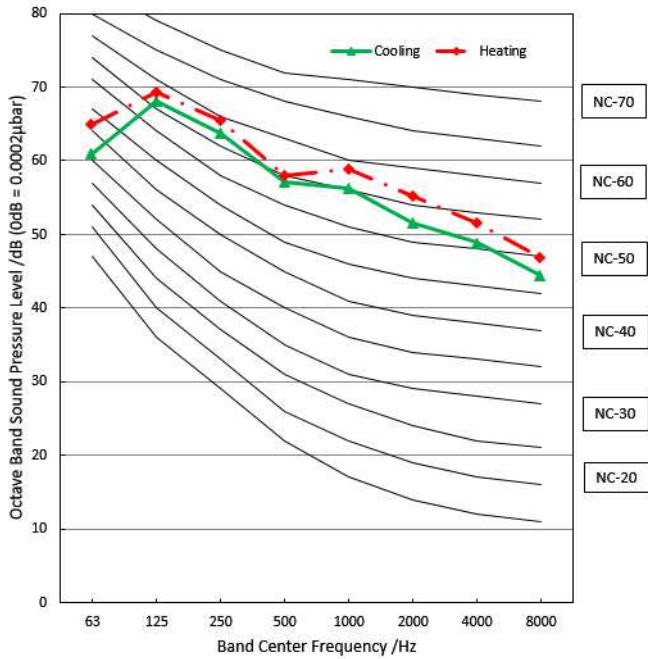

MOE30U-48HFN1-M

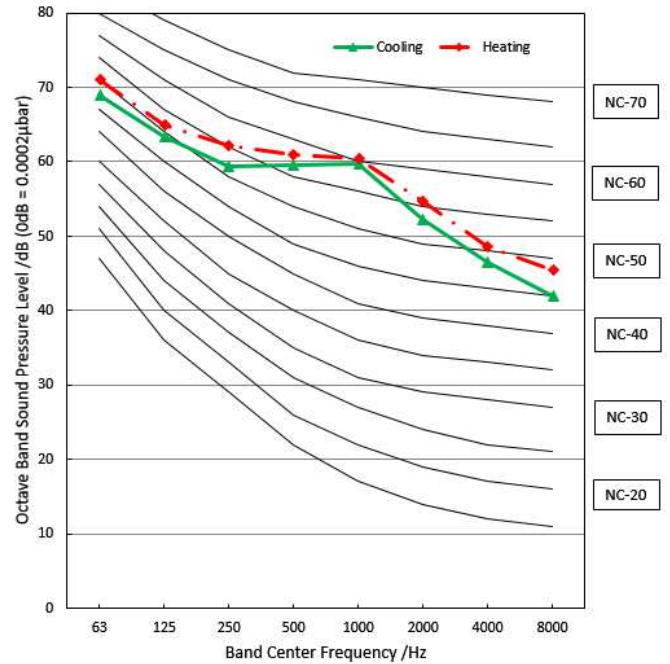

5. Refrigerant Cycle Diagrams

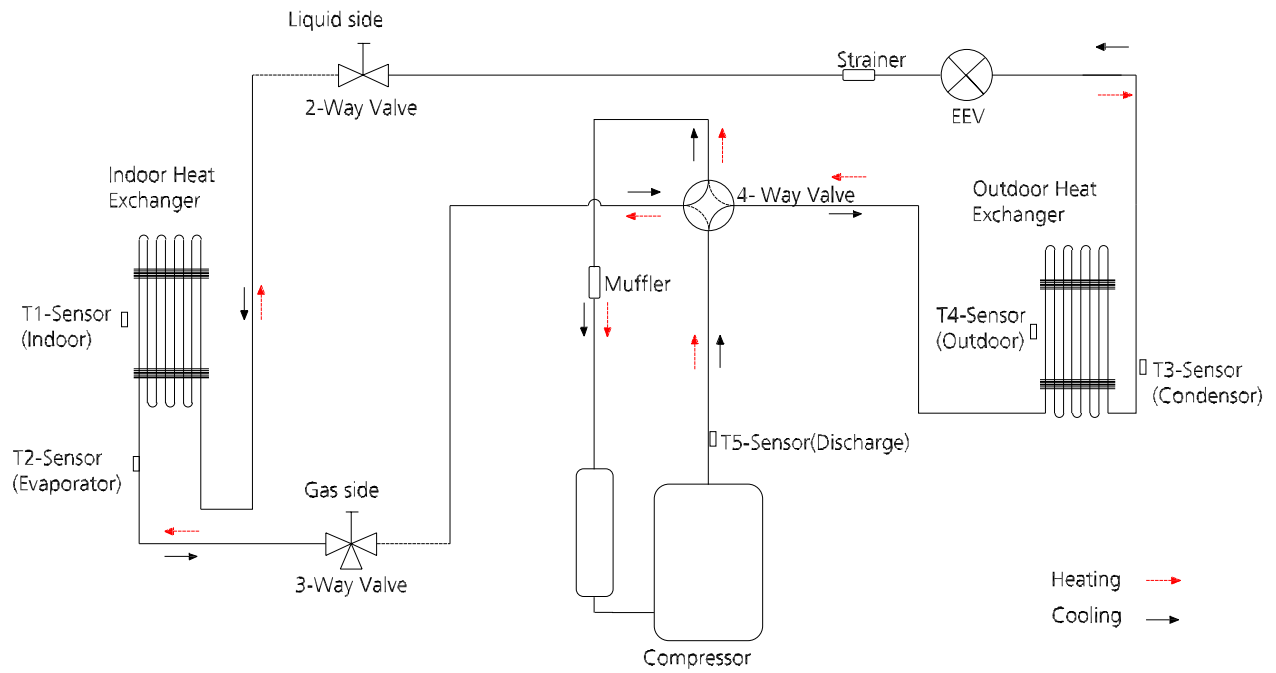

Model No.	Pipe Size (Diameter:ø) mm(inch)		Piping length (m/ft)		Elevation (m/ft)		Additional Refrigerant
	Gas	Liquid	Rated	Max.	Rated	Max.	
MOD31-24HFN1-MTOW	15.9(5/8)	9.52(3/8)	7.5/24.6	50/164	0	25/82	30g/m (0.32oz/ft)
MOD01-23HFN1-MTOW							
MOD30-24HFN1-MTOW							

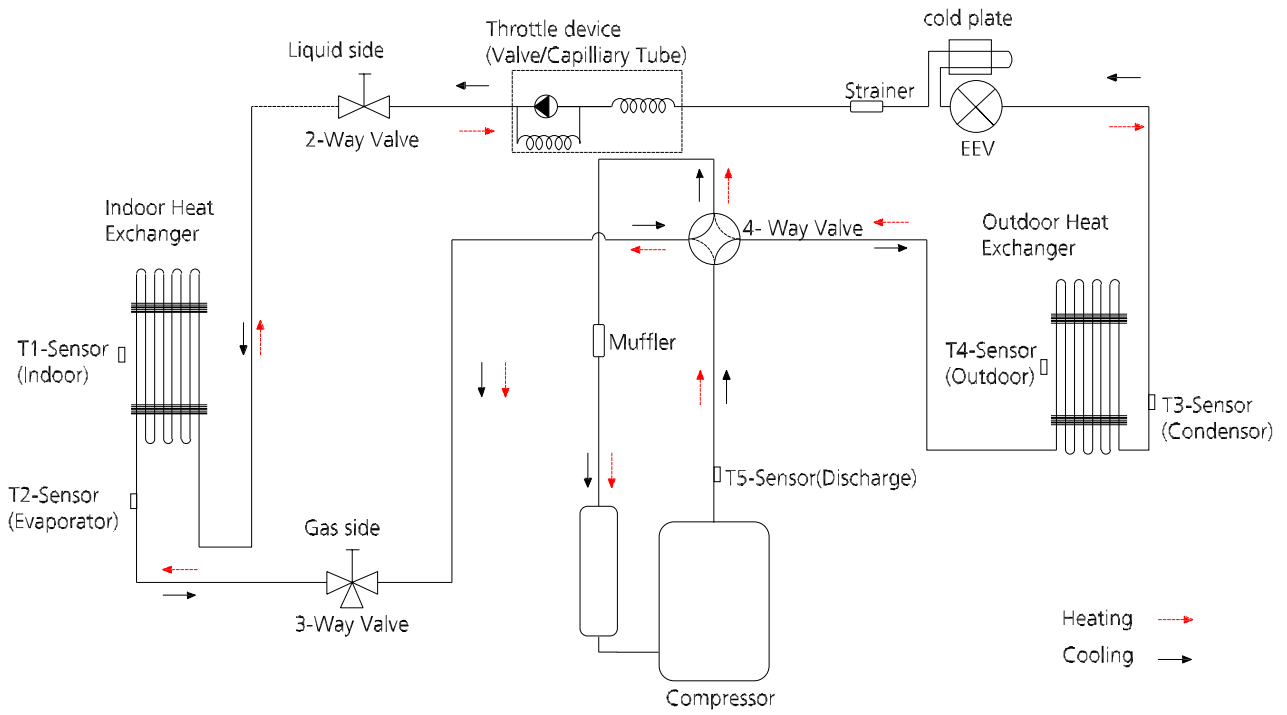

Model No.	Pipe Size (Diameter:ø) mm(inch)		Piping length (m/ft)		Elevation (m/ft)		Additional Refrigerant
	Gas	Liquid	Rated	Max.	Rated	Max.	
MOD30-24HFN1-MU0W	15.9(5/8)	9.52(3/8)	7.5/24.6	50/164	0	25/82	30g/m (0.32oz/ft)

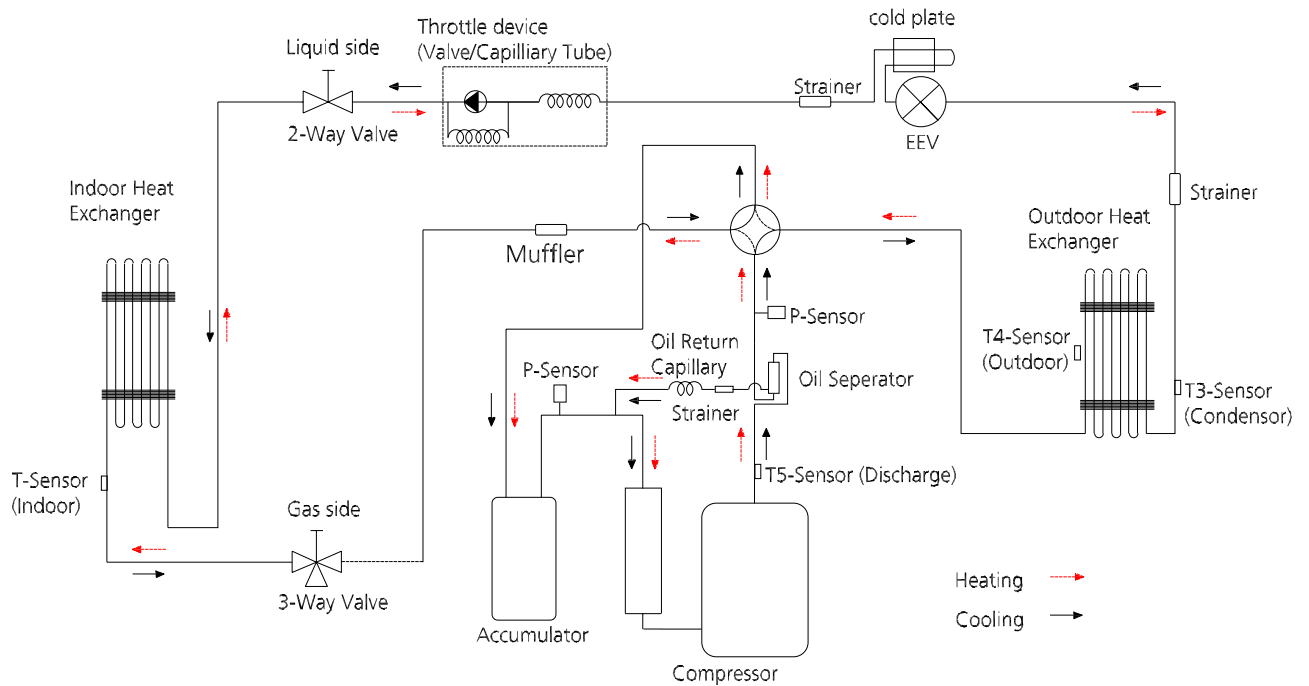

Model No.	Pipe Size (Diameter:ø) mm(inch)		Piping length (m/ft)		Elevation (m/ft)		Additional Refrigerant
	Gas	Liquid	Rated	Max.	Rated	Max.	
MOD30U-36HFN1-M	15.9(5/8)	9.52(3/8)	7.5/24.6	65/213.2	0	30/98.4	30g/m (0.32oz/ft)
MOE30U-48HFN1-M							

6. Electrical Wiring Diagrams

ODU Model	ODU Wiring Diagram
MOD31-24HFN1-MT0W	16022000019211
MOD01-23HFN1-MT0W	16022000025150
MOD30-24HFN1-MT0W	
MOD30-24HFN1-MU0W	16022000034529
MOD30U-36HFN1-M	16022000033770
MOE30U-48HFN1-M	16022000033772

ODU Model	ODU Main Printed Circuit Board	Inverter module printed board
MOD31-24HFN1-MT0W	17122000036588	/
MOD01-23HFN1-MT0W	17122000048172	17122000008629
MOD30-24HFN1-MT0W		17122000039428
MOD30-24HFN1-MU0W	17122000047742	/
MOD30U-36HFN1-M	17122000047742	/
MOE30U-48HFN1-M	17122000037804	17122000042012

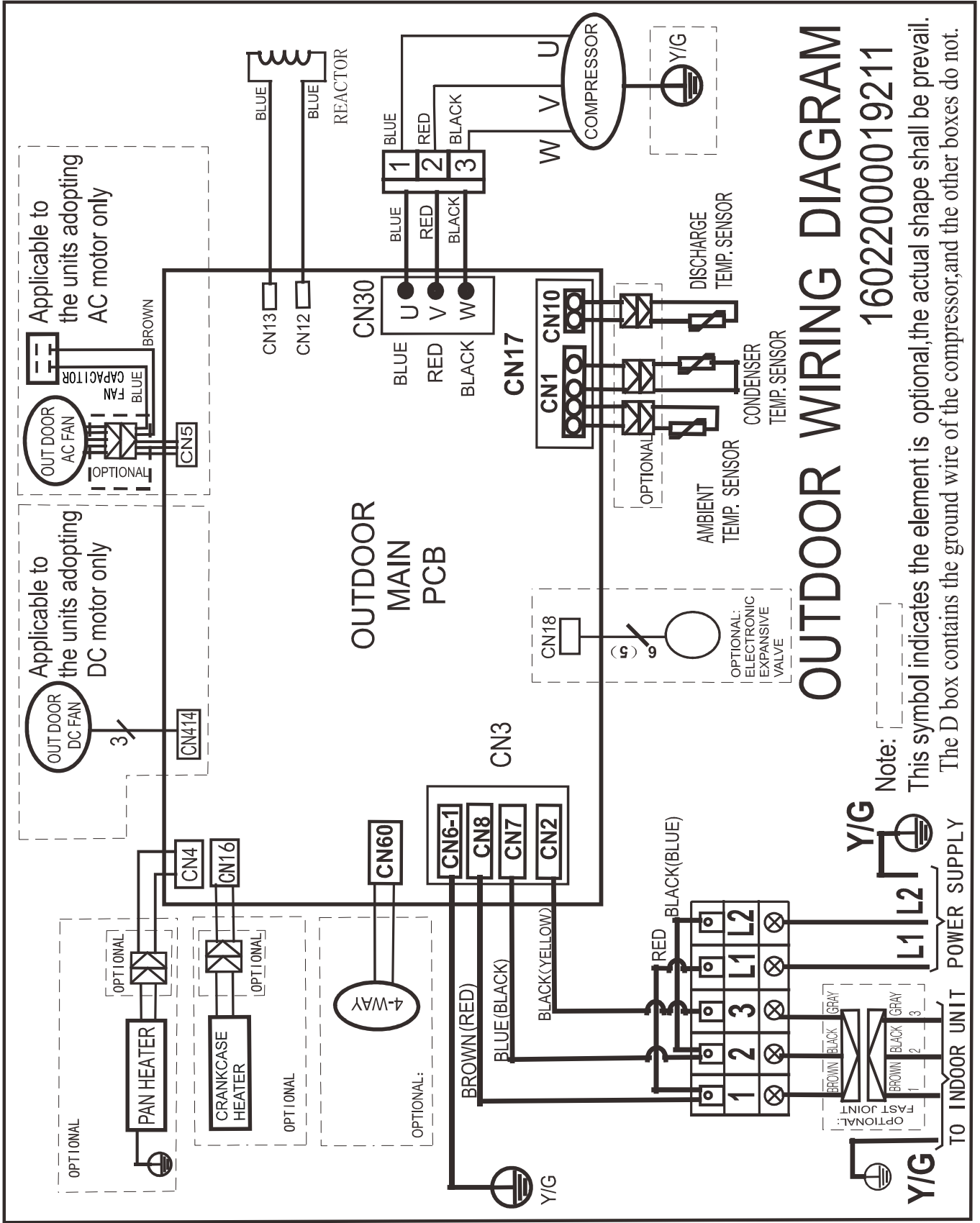

OUTDOOR WIRING DIAGRAM

16022000019211

Note:

This symbol indicates the element is optional, the actual shape shall be prevail. The D box contains the ground wire of the compressor, and the other boxes do not.

Outdoor unit wiring diagram: 1602200025150

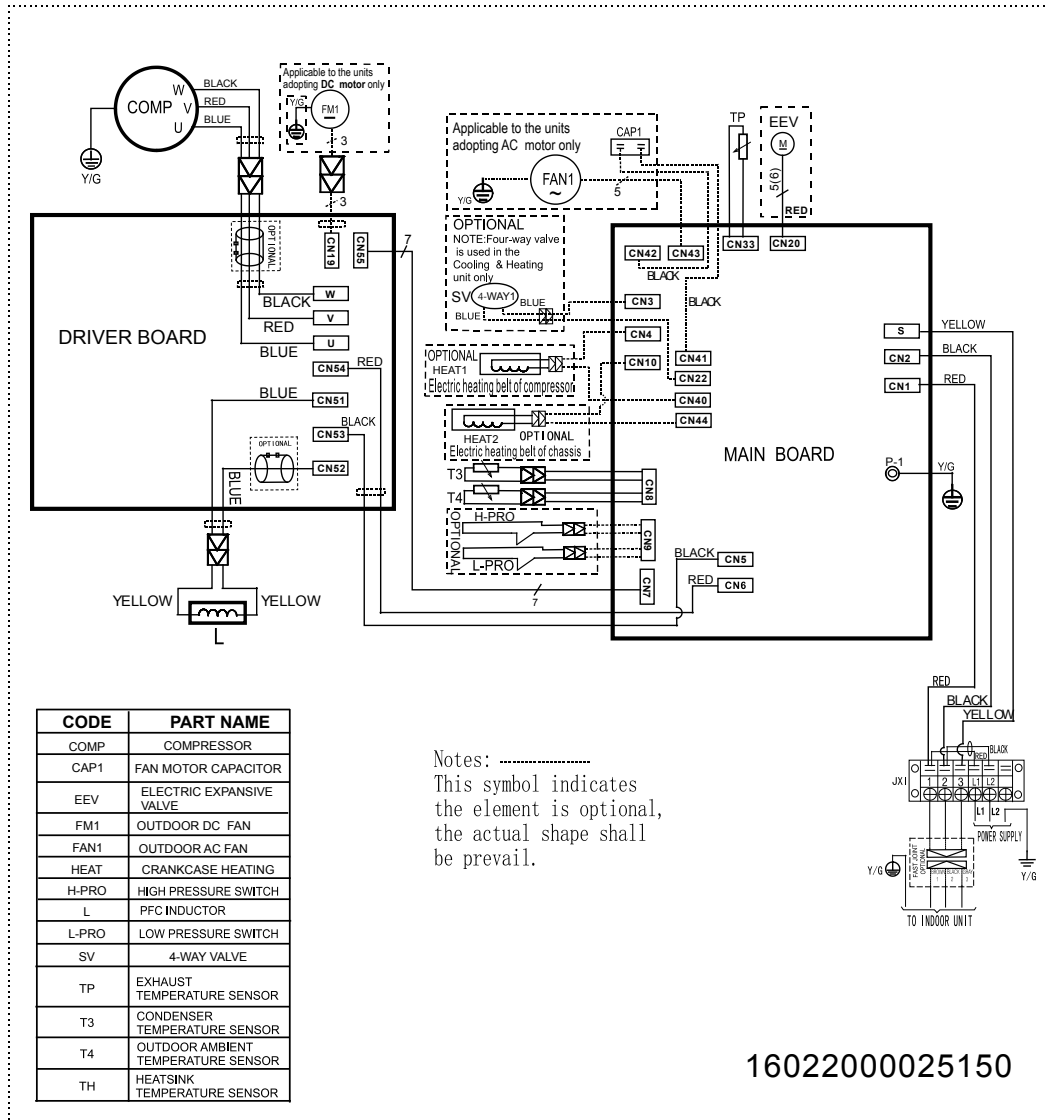

Outdoor unit wiring diagram: 16022000034529

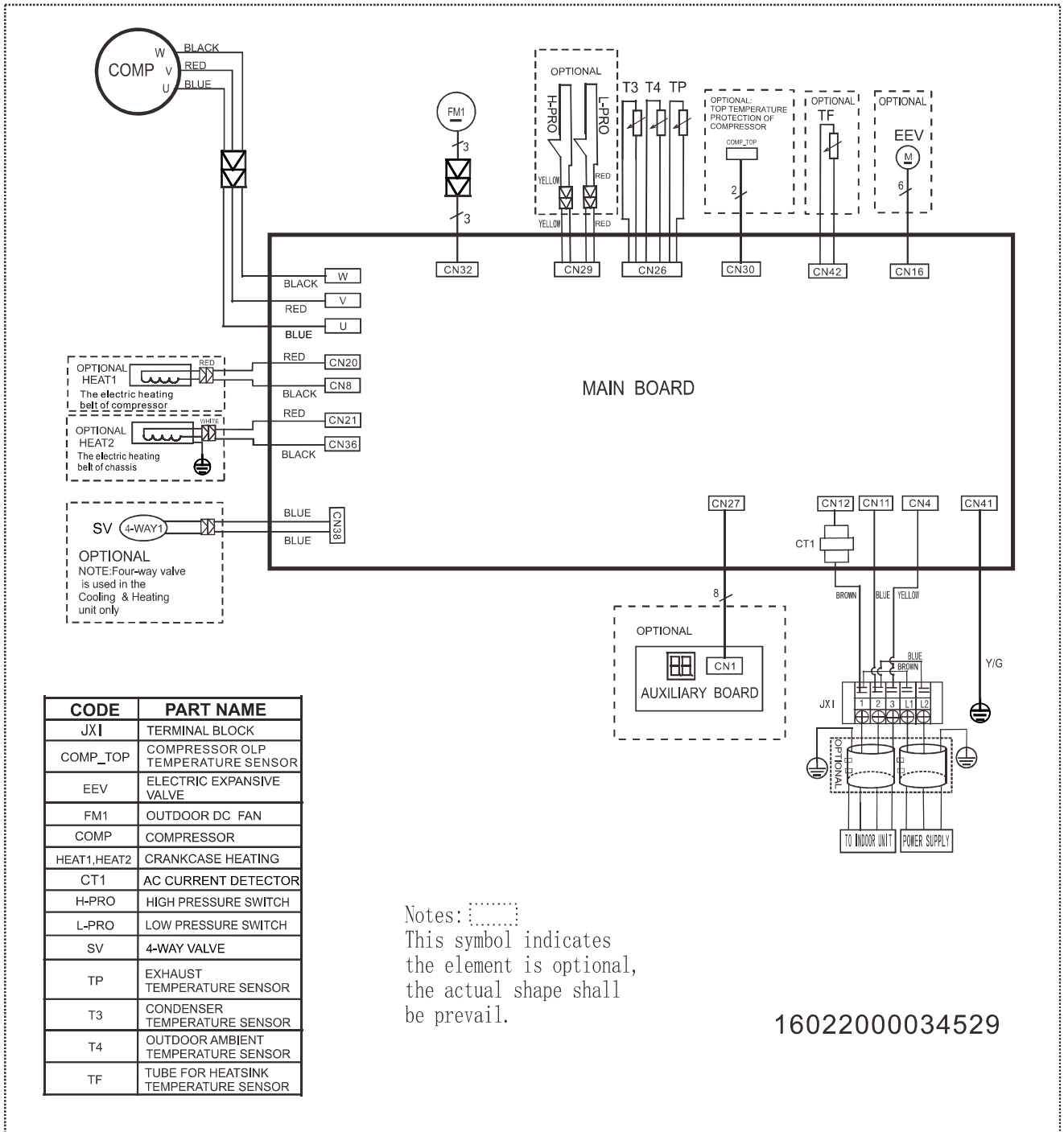

CODE	PART NAME
JX1	TERMINAL BLOCK
COMP_TOP	COMPRESSOR OLP TEMPERATURE SENSOR
EEV	ELECTRIC EXPANSIVE VALVE
FM1	OUTDOOR DC FAN
COMP	COMPRESSOR
HEAT1,HEAT2	CRANKCASE HEATING
CT1	AC CURRENT DETECTOR
H-PRO	HIGH PRESSURE SWITCH
L-PRO	LOW PRESSURE SWITCH
SV	4-WAY VALVE
TP	EXHAUST TEMPERATURE SENSOR
T3	CONDENSER TEMPERATURE SENSOR
T4	OUTDOOR AMBIENT TEMPERATURE SENSOR
TF	TUBE FOR HEATSINK TEMPERATURE SENSOR

Notes:
 This symbol indicates the element is optional, the actual shape shall be prevail.

16022000034529

Outdoor unit wiring diagram: 16022000033770

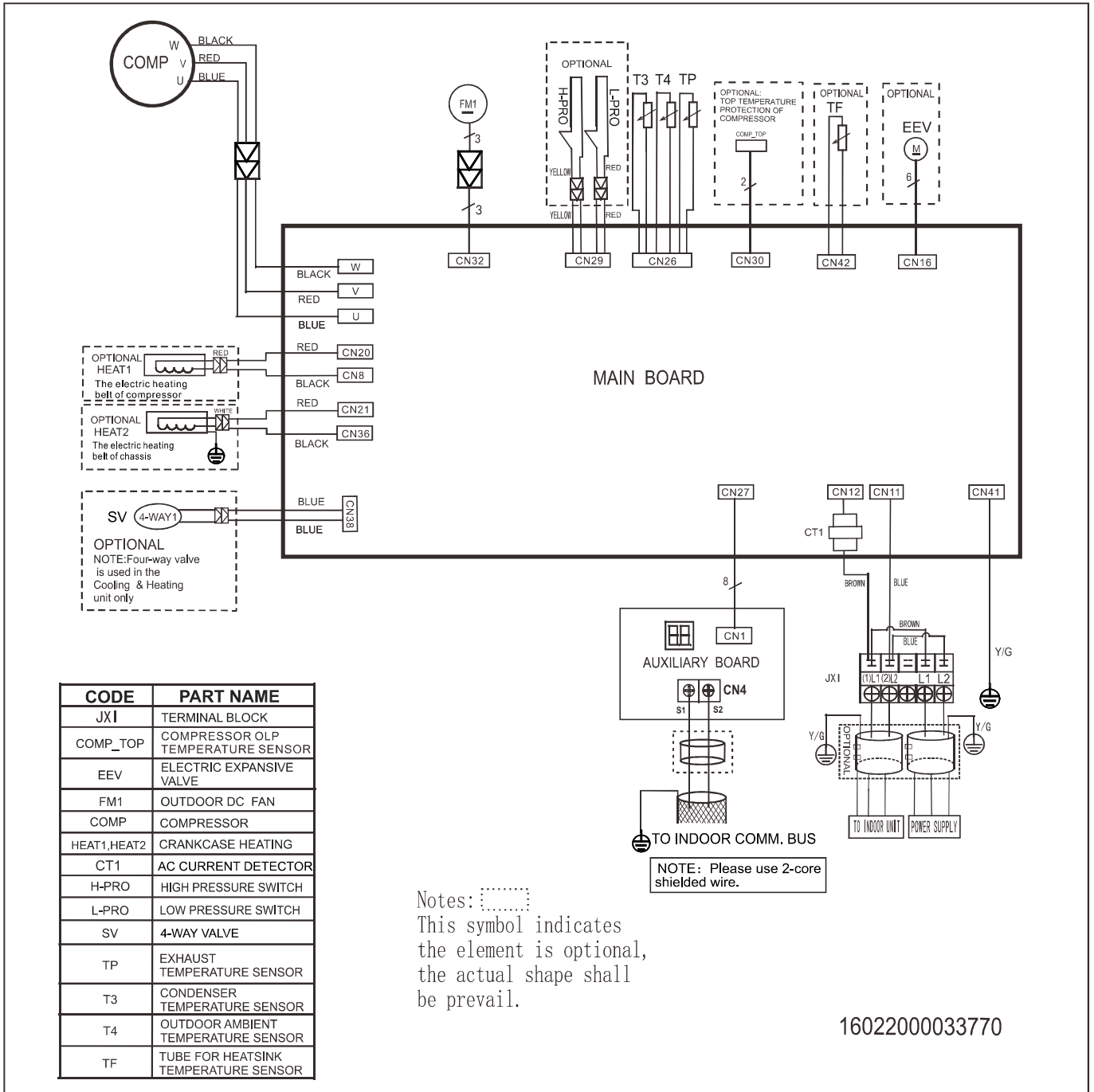

16022000033770

No.	Name	CN#	Meaning
1	Power Supply (CN3)	CN6-1	Earth: connect to Ground
		CN7	N_in: connect to N-line (208-230V AC input)
		CN8	L_in: connect to L-line (208-230V AC input)
2	S	CN2	S: connect to indoor unit communication
3	4-WAY	CN60	connect to 4 way valve, 208-230V AC when is ON.
4	HEAT1	CN4	connect to compressor heater, 208-230V AC when is ON
5	AC-FAN	CN11	connect to AC fan
6	HEAT2	CN16	connect to chassis heater, 208-230V AC when is ON
7	CN38	CN38	connect to PC communication
8	PMV	CN18	connect to Electric Expansion Valve
9	DC-FAN	CN414	connect to DC fan
10	FAN_IPM	IPM 501	IPM for DC fan
11	CN19	CN19	Internal drive motor
12	TESTPORT	CN23	used for testing
13	CN9	CN9	connect to PC communication
14	U	CN28	connect to compressor
	V	CN29	0V AC (standby)
	W	CN30	10-200V AC (running)
15	COMP_IPM	IPM 301	IPM for compressor
16	TP T4 T3	CN17	connect to pipe temp. sensor T3, ambient temp. sensor T4, exhaust temp. sensor TP

Note: This section is for reference only. Please take practicality as standard.

Outdoor unit printed circuit board diagram: 1712200002671/17122000048172

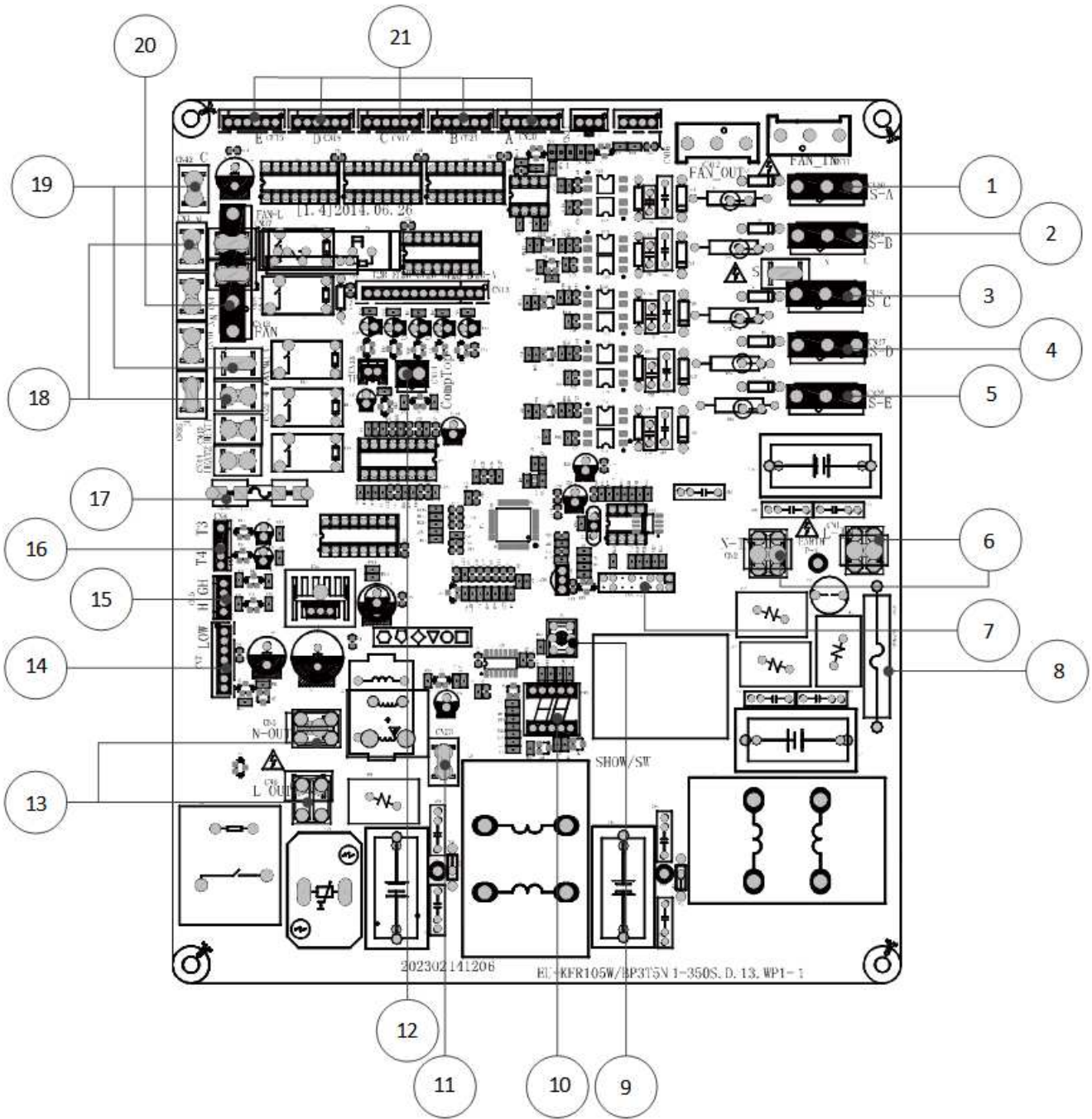

No.	Name	CN#	Meaning
1	S-A	CN30	Current loop communication A, signal wire, connect to the terminal (24V DC Pulse wave)
2	S-B	CN29	Current loop communication B, signal wire, connect to the terminal (24V DC Pulse wave)
3	S-C	CN28	Current loop communication C, signal wire, connect to the terminal (24V DC Pulse wave)
4	S-D	CN30	Current loop communication D, signal wire, connect to the terminal (24V DC Pulse wave)
5	S-E	CN30	Current loop communication E, signal wire, connect to the terminal (24V DC Pulse wave)
6	L-IN	CN1	Power supply, connect to the terminal (208-230V AC)
	N-IN	CN2	
7	Test report	CONdebug	Connect to detector
8	Fuse	Fuse 1	Fuse T30A/250V
9	SW1	SW1	Digital display button
10	DSP1	DSP1	Digital display
11	CN23	CN23	CN23 reserve
12	CN14	CN14	Connect to exhaust temperature sensor
13	N-OUT	CN5	Connect to the terminal (208-230V AC)
	L-OUT	CN6	
14	CN7	CN7	Connect to inverter driver
15	LOW / HIGH	CN9	Connect to high and low pressure sensor
16	T3 / T4	CN8	Connect to T3 / T4 temperature sensor
17	Fuse	Fuse 2	Fuse 5A/250V
18	L	CN22	Connect to the 4-way valve. When the 4-way is ON, output 208-230V AC.
	N	CN3	
19	CN42	CN42	Connect to motor capacitor
	CN41	CN41	
20	AC Fan	CN43	Connect to AC fan motor
21	Electronic Expansion valve	CN20	connect to Electric Expansion Valve A
		CN21	connect to Electric Expansion Valve B
		CN17	connect to Electric Expansion Valve C
		CN18	connect to Electric Expansion Valve D
		CN19	connect to Electric Expansion Valve E

Note: This section is for reference only. Please take practicality as standard.

Outdoor unit IPM board diagram: 17122000008629

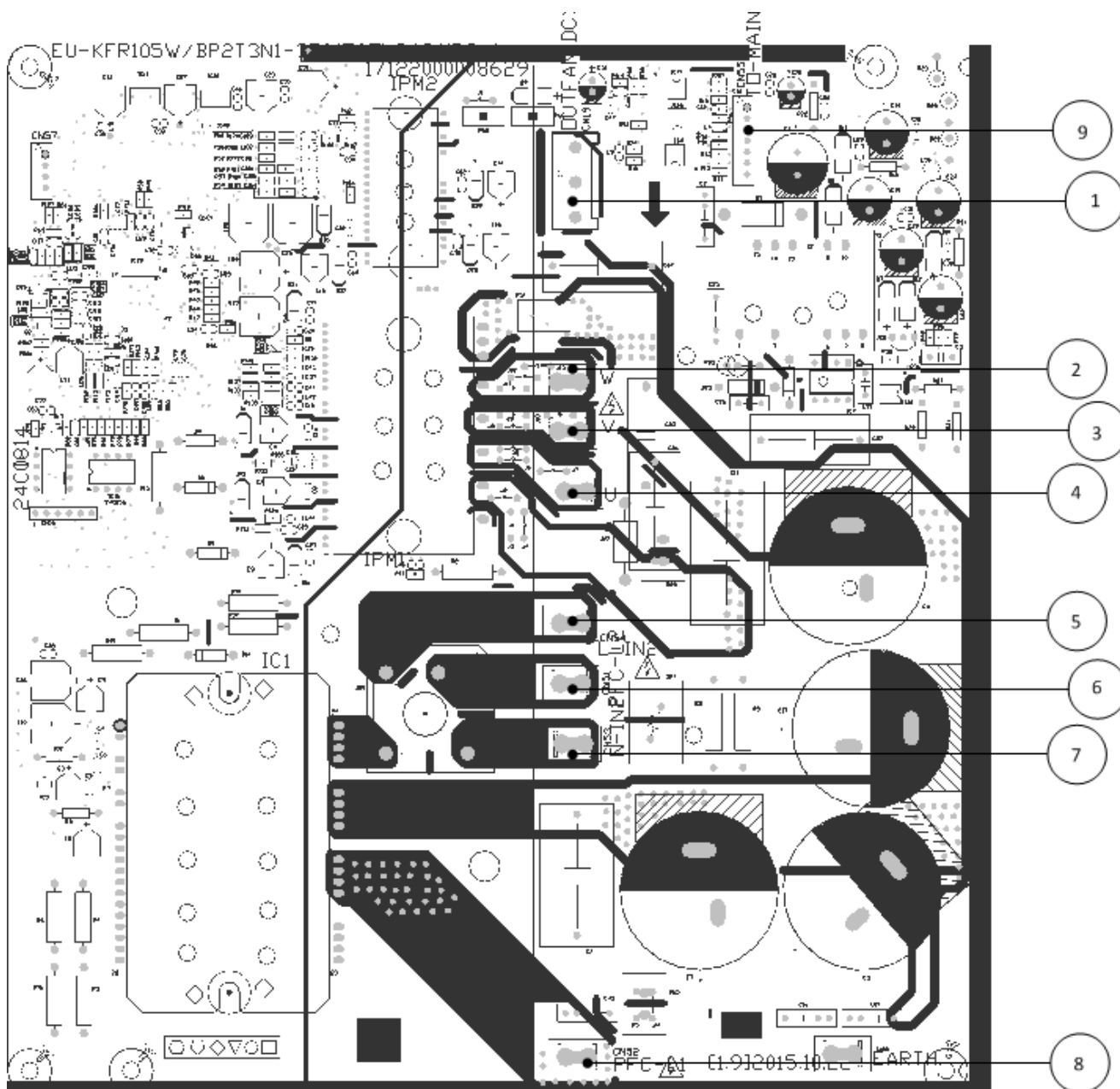

No.	Name	CN#	Meaning
1	OUT FAN (DC)	CN19	Connect to DC motor
2	W	J13	Connect to compressor W
3	V	J10	Connect to compressor V
4	U	J7	Connect to compressor U
5	CN54	CN54	Connect to main PCB CN6
6	CN51	CN51	Connect to PFC inductor
7	CN53	CN53	Connect to main PCB CN5
8	CN52	CN52	Connect to PFC inductor
9	CN55	CN55	Connect to main PCB CN7

Outdoor unit IPM board diagram: 17122000039428/17122000038756

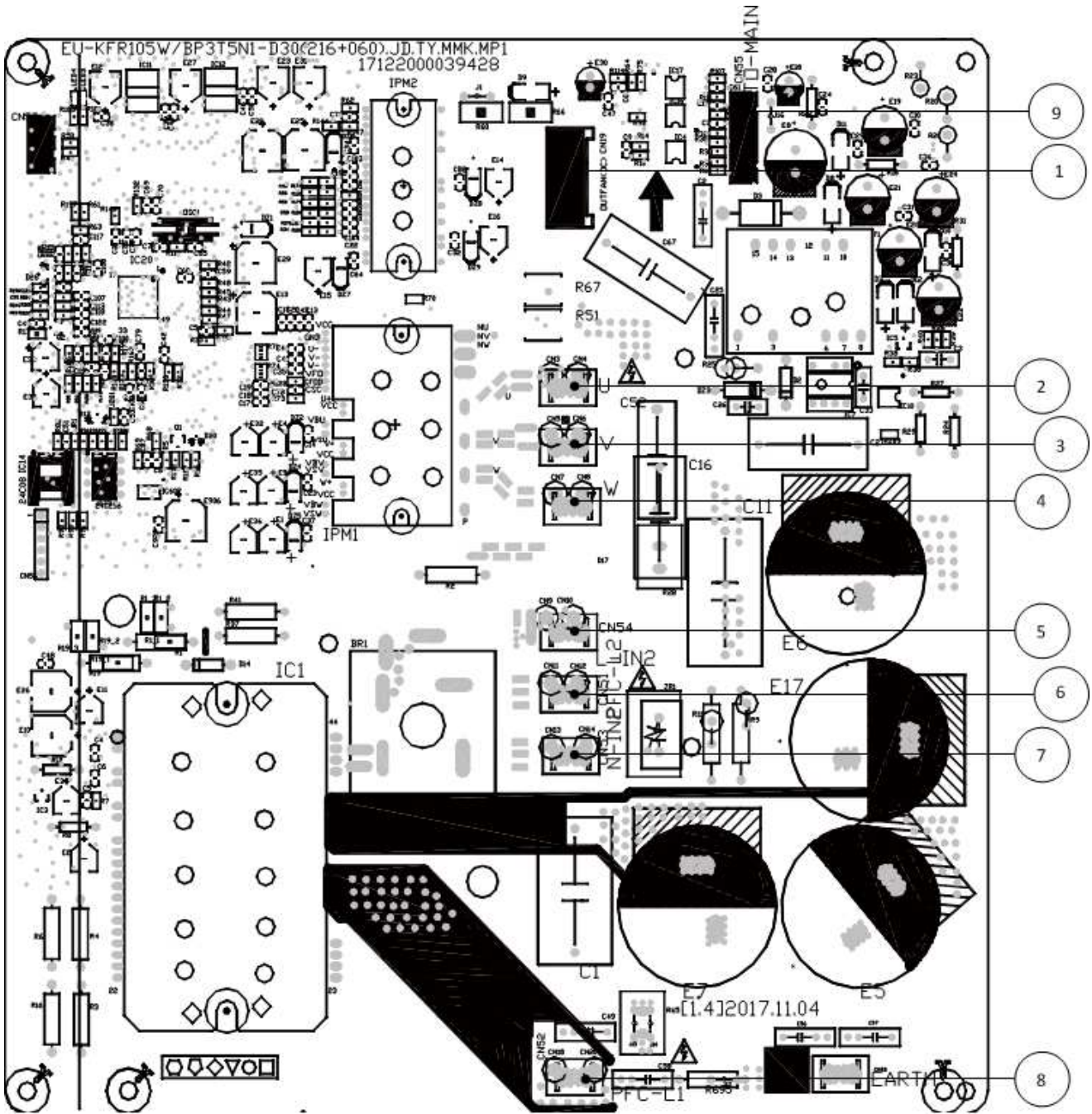

No.	Name	CN#	Meaning
1	OUT FAN (DC)	CN19	Connect to DC motor
2	U	CN3/CN4	Connect to compressor U
3	V	CN5/CN6	Connect to compressor V
4	W	CN7/CN8	Connect to compressor W
5	CN54	CN54	Connect to main PCB CN6
6	CN51	CN51	Connect to PFC inductor
7	CN53	CN53	Connect to main PCB CN5
8	CN52	CN52	Connect to PFC inductor
9	CN55	CN55	Connect to main PCB CN7

No.	Name	CN#	Meaning
1	Power Supply	CN11	N_in: connect to N-line (208-230V AC input)
		CN12	L_in: connect to L-line (208-230V AC input)
2	EEV-A	CN16	connect to electric expansion valve
	EEV-B	CN13	
	EEV-C	CN3	
	EEV-D	CN15	
	EEV-E	CN1	
	EEV-F	CN17	
	EEV-G	CN14	
3	T3 T4 TP	CN26	connect to pipe temp. sensor T3, ambient temp. sensor T4, exhaust temp. sensor TP
4	H-PRO,L-RPO	CN29	connect to high and low pressure switch(pin1-pin2&pin3-pin4:5VDC pulse wave)
5	OLP TEMP. SENSOR	CN30	connect to compressor top temp. sensor (5VDC Pulse wave)
6	TESTPORT	CN24	used for testing
7	COMPRESSOR	U	connect to compressor
		V	0V AC (standby)
		W	10-200V AC (running)
8	DC-FAN	CN32	connect to DC fan
9	S-E	CN31	S: connect to indoor unit communication(pin1-pin2: 24VDC Pulse wave; pin2-pin3: 208-230V AC input)
	S-D	CN5	
	S-C(mono)	CN34	
	S-B	CN2	
	S-A	CN4	

No.	Name	CN#	Meaning
10	HEAT_D	CN8	connect to the heater, 208-230V AC when is ON
		CN20	
11	HEAT_Y	CN21	
		CN36	
12	4-WAY	CN38	connect to 4 way valve, 208-230V AC when is ON.
13	/	CN27	connect to key board CN1

Note: This section is for reference only. Please take practicality as standard.

Outdoor unit printed circuit board diagram: 17122000037804

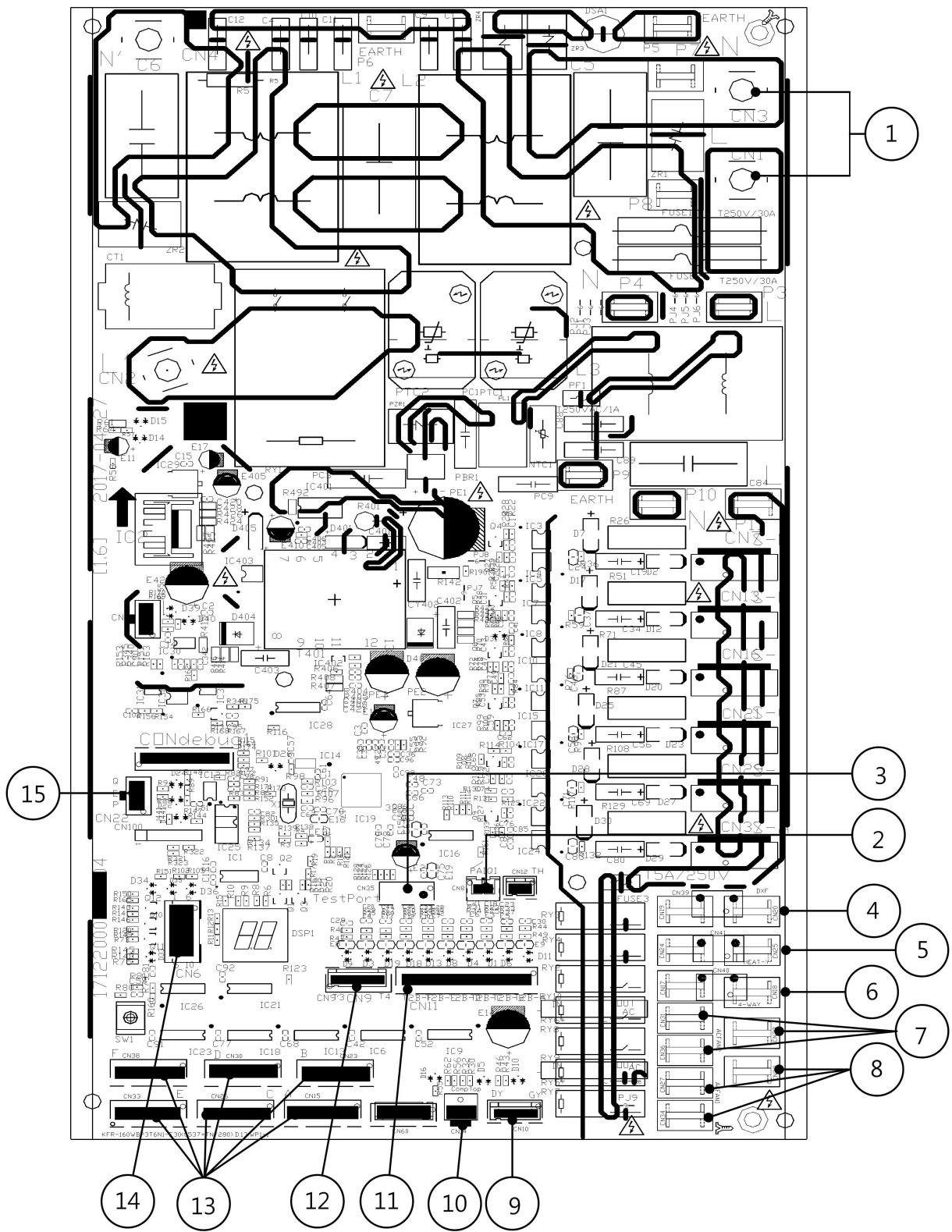

No.	Name	CN#	Meaning
1	Power Supply	CN1	L1_in: connect to L1-line (230V AC input)
		CN3	L2_in: connect to L2-line (230V AC input)
2	TP	CN8	Exhaust temp. sensor TP
3	TESTPORT	CN35	used for testing
4	HEAT1	CN19/CN20	connect to chassis heater, 208-230V AC when is ON
5	HEAT2	CN24/CN25	connect to compressor heater, 208-230V AC when is ON
6	4-WAY	CN17/CN18	connect to 4 way valve, 208-230V AC when is ON.
7	AC-FAN2	CN31/CN36/CN28	connect to AC fan2
8	AC-FAN1	CN27/CN34/CN32	connect to AC fan1
9	H-PRO/L-PRO	CN10	connect to low&high pressure switch
10	Compressor Top	CN14	connect to compressor top temperature sensor
11	T2B	CN11	connect to pipe temp. sensor T2B
12	T4 T3	CN9	connect to pipe temp. sensor T3, ambient temp. sensor T4
13	PMV	CN15/CN23/CN26/ CN30/CN33/CN38	connect to Electric Expansion Valve(A~F)
14	/	CN6	connect to IPM&PFC board CN9
15	PQE	CN22	Communication to indoor unit

Outdoor unit IPM board diagram: 17122000042012

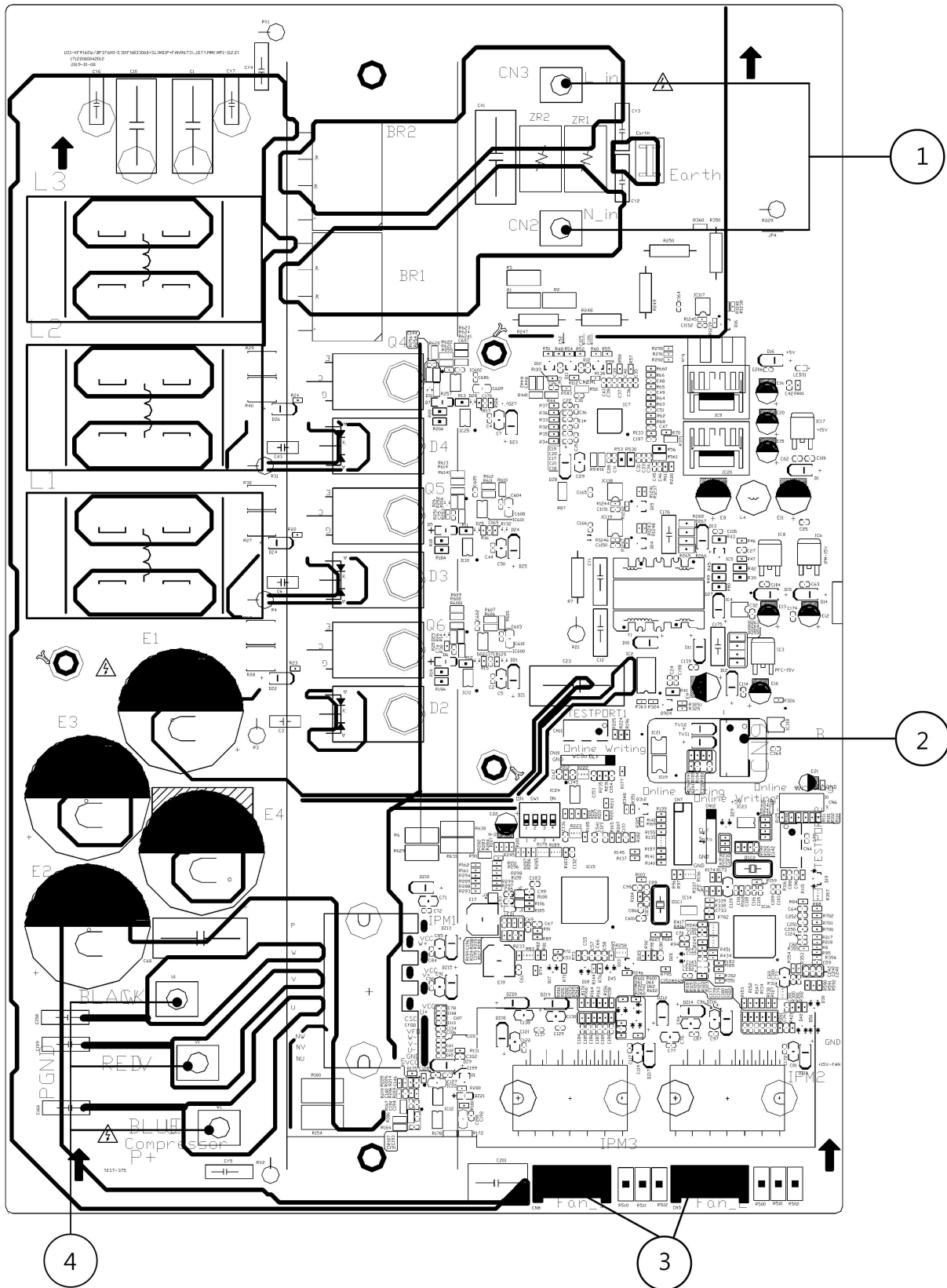

No.	Name	CN#	Meaning
1	Power Supply	CN3	connect to main board L-Out
		CN2	connect to main board N-Out
2	/	CN9	connect to main board CN6
3	FAN_DC	FAN_1/FAN_2	connect to outdoor DC fan 1& DC fan 2
4	CN_COMP	U1	connect to compressor
		V1	
		W1	

Note: This section is for reference only. Please take practicality as standard.

Installation

Contents

1. Installation Overview
2. Location Selection
3. Indoor Unit Installation
4. Outdoor Unit Installation
5. Drainage Pipe Installation
6. Refrigerant Pipe Installation
7. Vacuum Drying and Leakage Checking
8. Additional Refrigerant Charge
9. Engineering of Insulation
10. Engineering of Electrical Wiring
11. Test Operation

1. Installation Overview

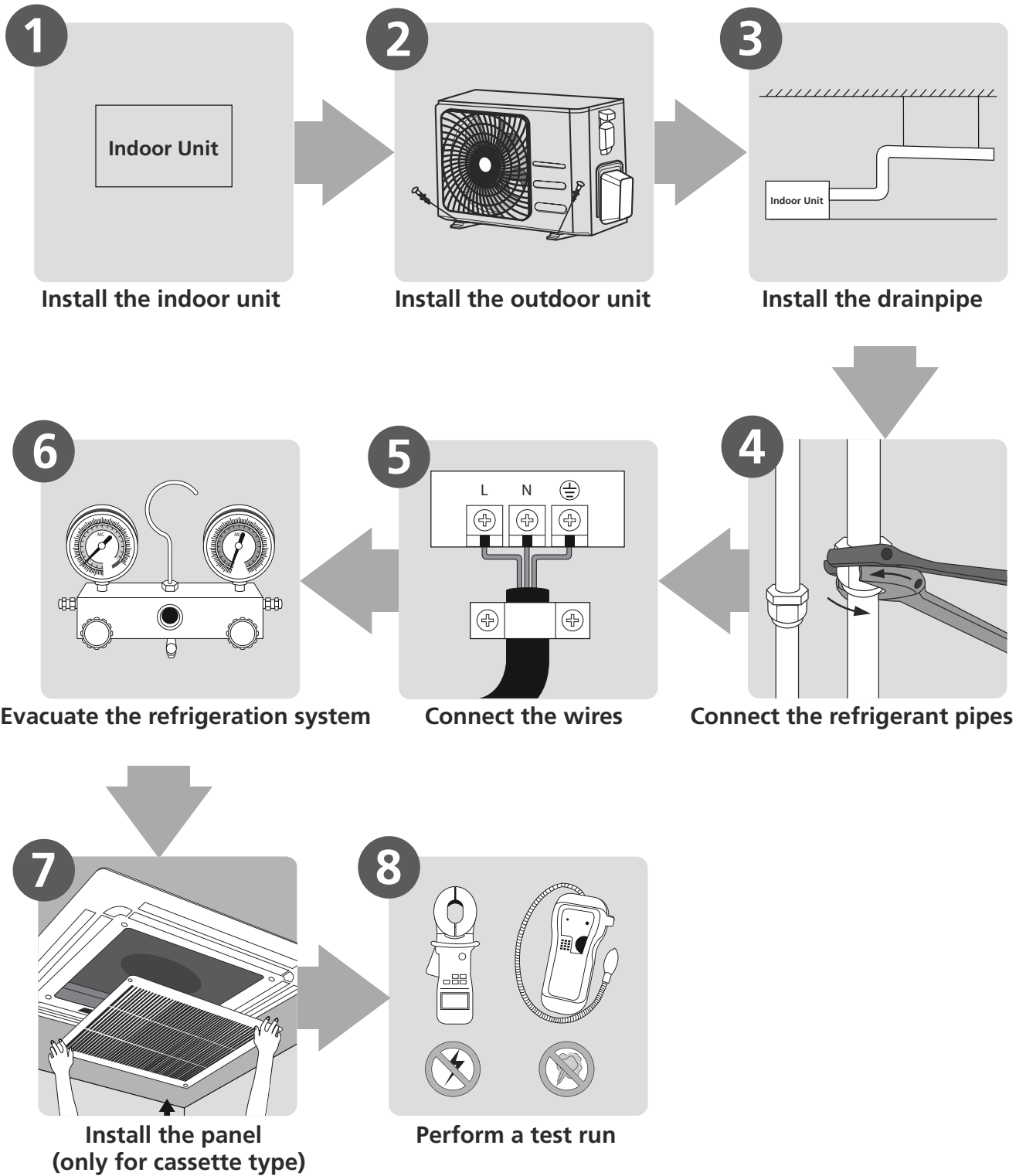

2. Location selection

2.1 Unit location selection can refer to installation manual.

2.2 DO NOT install the unit in the following locations:

- Where oil drilling or fracking is taking place.
- Coastal areas with high salt content in the air.
- Areas with caustic gases in the air, such as near hot springs.
- Areas with power fluctuations, such as factories.
- Enclosed spaces, such as cabinets.
- Areas with strong electromagnetic waves.
- Areas that store flammable materials or gas.
- Rooms with high humidity, such as bathrooms or laundry rooms.
- If possible, DO NOT install the unit where it is exposed to direct sunlight.

2.3 The minimum distance between the outdoor unit and walls described in the installation guide does not apply to airtight rooms. Be sure to keep the unit unobstructed in at least two of the three directions (M, N, P)

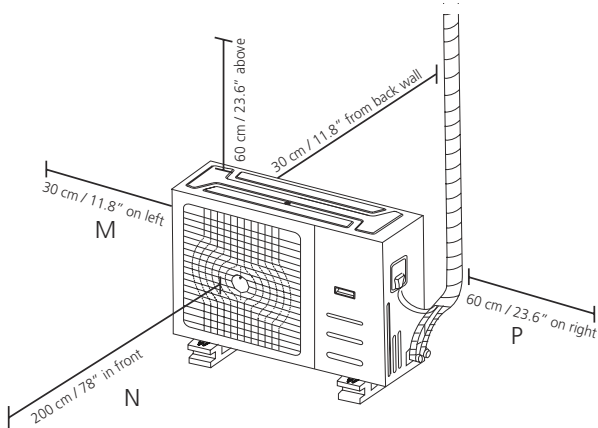

2.4 Rows of series installation

The relations between H, A and L are as follows.

	L	A
L ≤ H	$L \leq 1/2H$	25 cm / 9.8" or more
	$1/2H < L \leq H$	30 cm / 11.8" or more
L > H	Can not be installed	

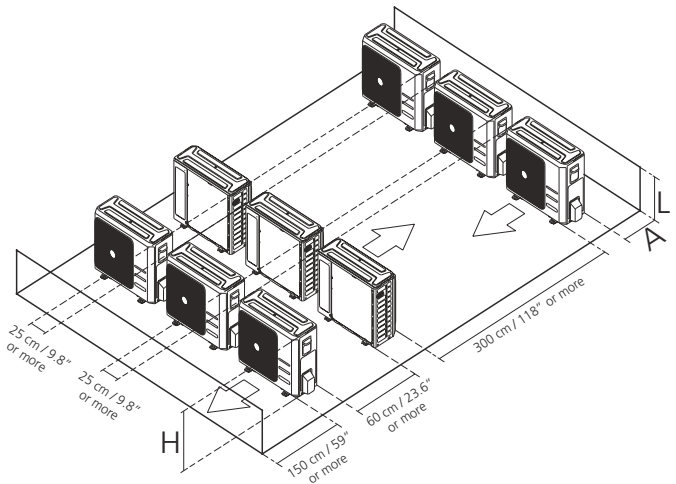

DO NOT install the rows of series like following figure.

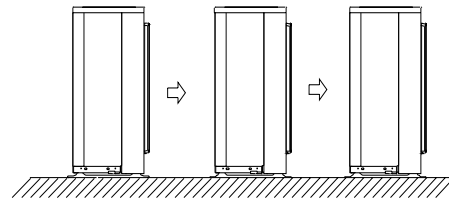

2.5. If the location is exposed to strong winds (for example: near a seaside), the unit must be placed against the wall to shelter it from the wind. If necessary, use an awning.

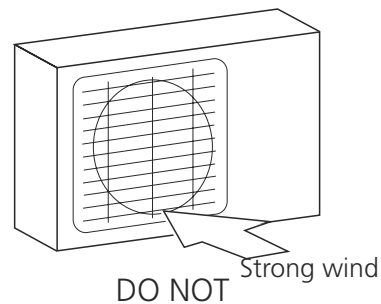

3. Indoor Unit Installation(AHU)

3.1 Service space for indoor unit

Plenum Clearances:

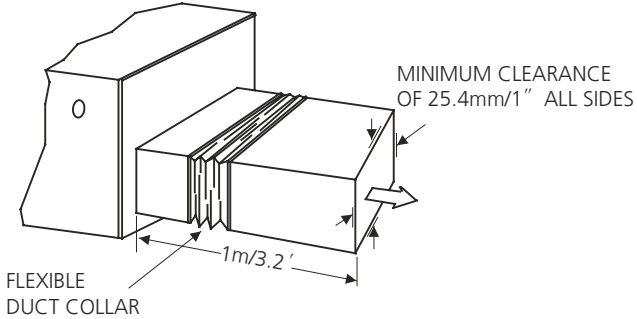

3.2 Install the main body

You can choose vertical or horizontal installation in accordance with the applications.

Vertical Discharge

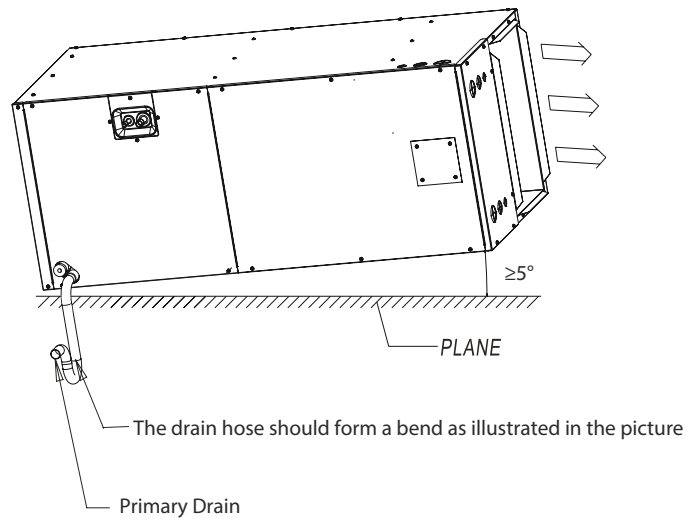
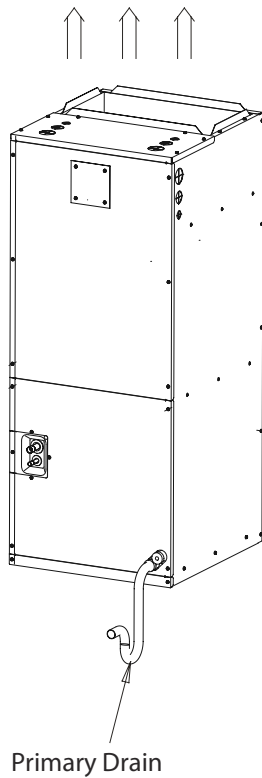

Note: For drain the condensate out of the unit smoothly, please place the unit with a small angle when horizontal installation..

For the Horizontal left installation and vertical down installation, the direction of the evaporator should be changed and the drain pan should be removed first. Please do it according to the following steps:

1. Remove the fixed plate of the filter, then take the filter off.

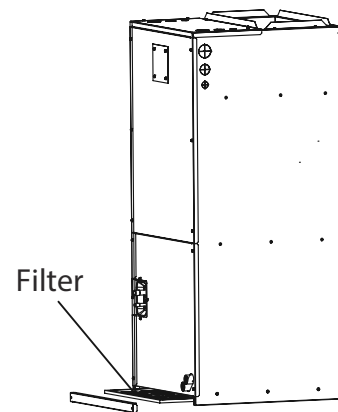

2. Open the evaporator cover and remove the drainage plug.

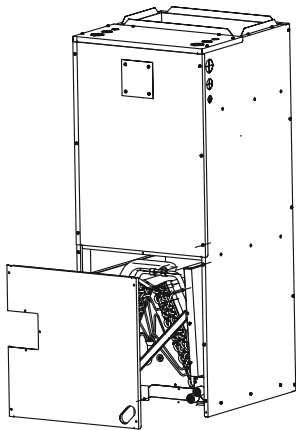

3. Remove the drain pan fixed plate and supporting plate.

Take out the evaporator and rotate it 180°

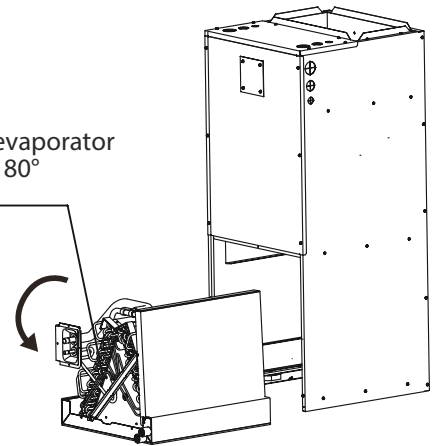

6. Reinstall the evaporator and drain pan.

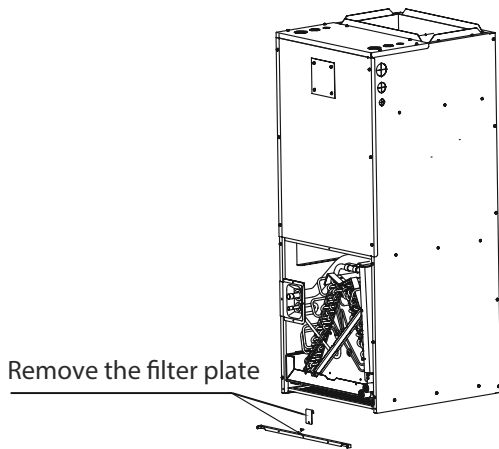

Remove the filter plate

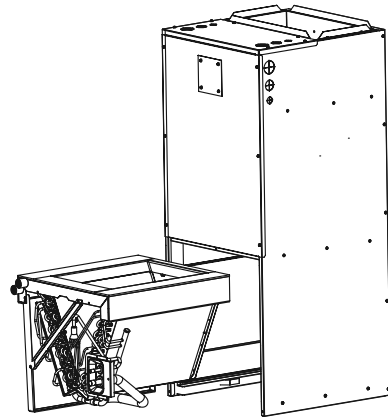

4. Remove pipe temperature sensor and room temperature sensor.

7. The pipe temperature sensor should be put it back in the same position. Attach the room temperature to the evaporator output pipe protective sleeve.

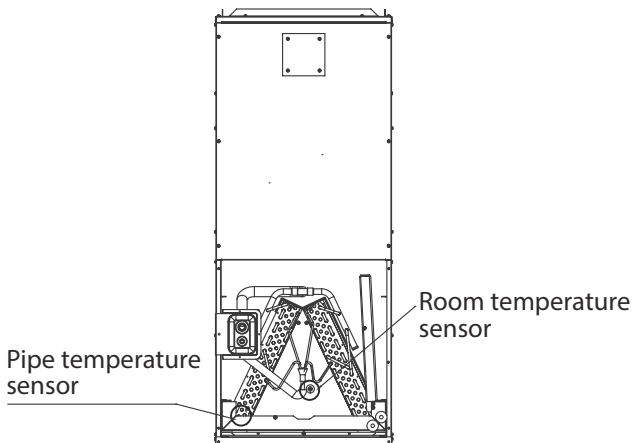

Pipe temperature sensor

Room temperature sensor

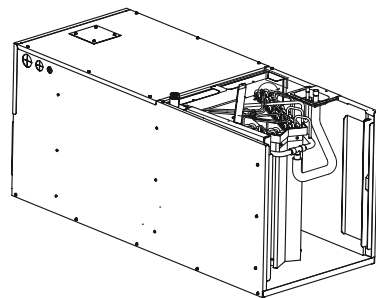

Pipe temperature line and room temperature line pass through the top of the water intake plate and the left side plate.

5. Take out the evaporator and drain pan and rotate 180°.

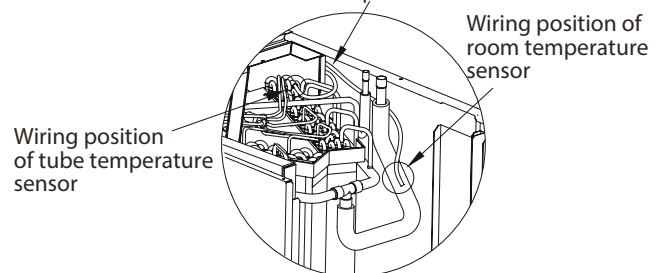

Wiring position of tube temperature sensor

Wiring position of room temperature sensor

8. Reinstall the drain pan fixed plate and supporting plate.

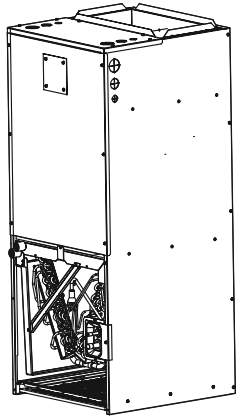

9. Reinstall evaporator cover.

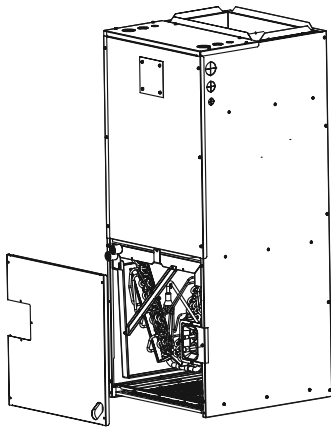

10. Reinstall the filter and filter plate.

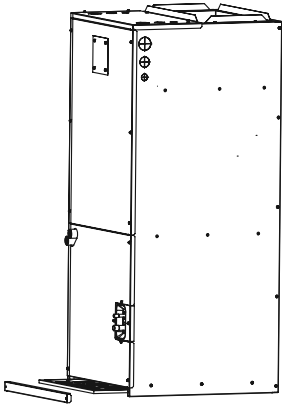

11. Open the upper cover.

12. Open the cover of the electronic control box.

13. Connect the wire according to the wiring diagram.





14. Connect the pipes.

15. Install the drainage pipes.

For horizontal installation, a drain pan(not supplied) must be installed.

3.3 Install the Electric Auxiliary Heat Module (for some models)

Accessories

Name	Shape	Quantity
Manual		1
Seal sponge		1
Screw		2
Rubber cap		1
Wiring diagram		1

NOTE:

Installation must be performed by an authorized dealer or specialist. Please make necessary protection when installing the unit.

1. Loosen 10 fasten screws as shown below, then take down the upper cover assembly and remove the cover plate.

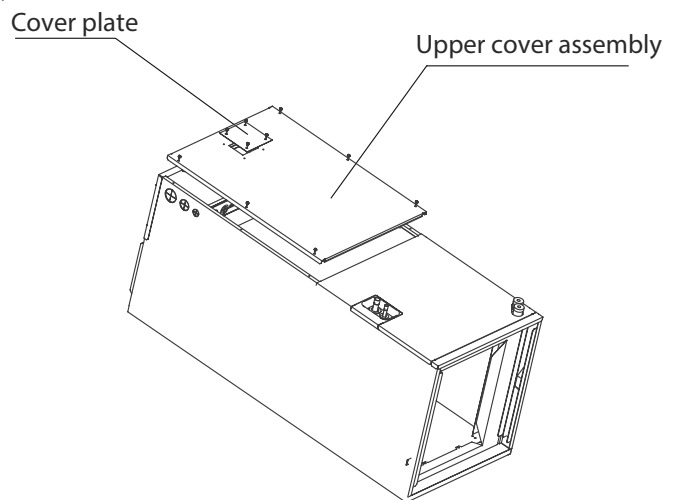

2. Loosen the fasten screw and take down the electric auxiliary heat cover.

NOTE:

For model EAH-05A(UL)& EAH-10A(UL), remove any one of the electric auxiliary heat cover.

For Model EAH-15A(UL)& EAH-20A(UL), both of the covers should be removed.

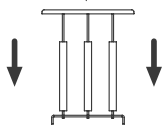
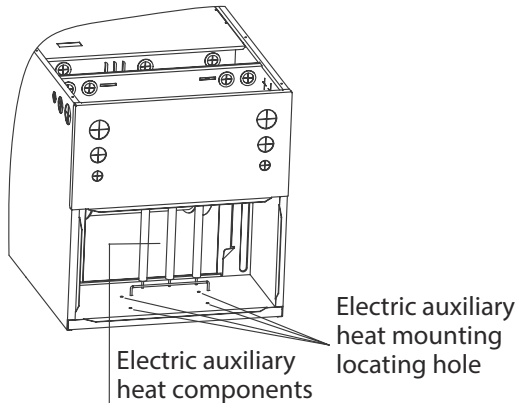
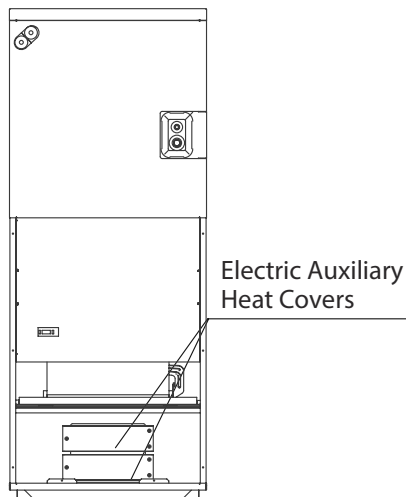

Electric auxiliary heat components are mounted downward.

3. Install the electric auxiliary heat module.

NOTE:

For model EAH-05A(UL)&EAH-10A(UL):

①:Electric auxiliary heat assembly

②:Electric auxiliary heat cover

For model EAH-15A(UL)&EAH-20A(UL):

① ②:Electric auxiliary heat assembly

4. Using two screws (packed with accessories) to install the electric control components.

NOTE:

- Ensure that the buckles of the electrical installation board are clipped into the rectangular gap of the fixing plate of the fan wheel.
- The wire hole for the connective cable must be attached with rubber ring.

Fixed screw position

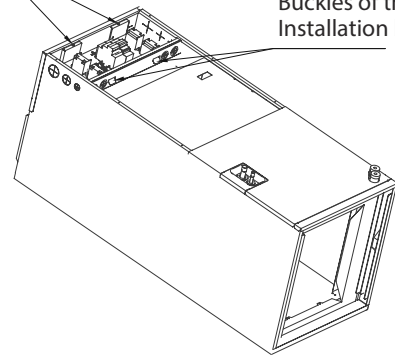

Indoor unit wiring diagram

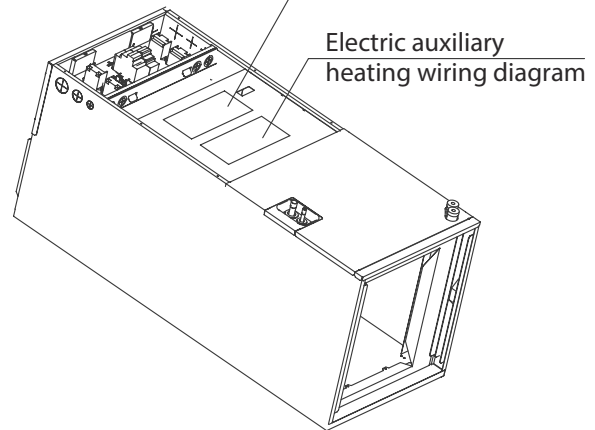

NOTE:

- Electric auxiliary heating wiring diagram packed with the accessories.
 - Please paste the wiring diagram in the designated position after the installation of electric auxiliary heating modules is completed, for convenience of later maintenance.
5. Re-install the upper cover assembly. Use four screws to fasten the rubber cap assembly. (packed with the accessories)

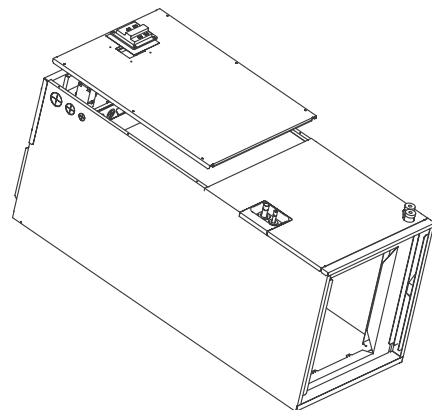

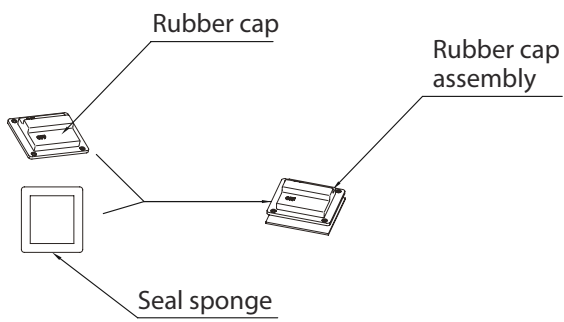

NOTE:

Fire prevention materials shall be used for air duct installation. Infammable and explosive materials shall not exist around the air duct. Install electrical auxiliary heating power supply wire diameter specification of at least 8AWG.

4. Outdoor unit installation

4.1 Service space for outdoor unit

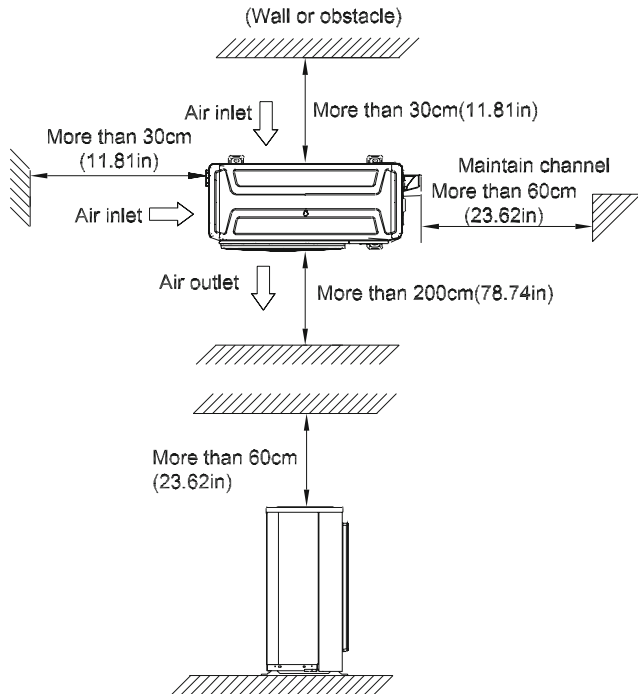

4.2 Bolt pitch

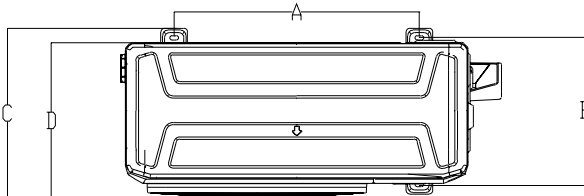

Panel Plate	Unit	D	A	B	C
B30	mm	333	514	340	365
	inch	13.11	20.23	13.39	14.37
CA30	mm	363	540	350	375
	inch	14.29	21.26	13.78	14.8
D30	mm	410	673	403	455
	inch	16.14	26.50	15.87	17.9
X2	mm	303	452	286	314
	inch	11.93	17.80	11.26	12.36
X3	mm	330	511	317	346
	inch	12.99	20.12	12.48	13.62
X4	mm	342	663	354	394
	inch	13.46	26.1	13.94	15.5
E30	mm	415	634	404	457
	inch	16.34	24.96	15.9	17.99
590	mm	350	590	378	400
	inch	13.78	23.23	14.88	15.75

4.3 Install Outdoor Unit

Fix the outdoor unit with anchor bolts(M10)

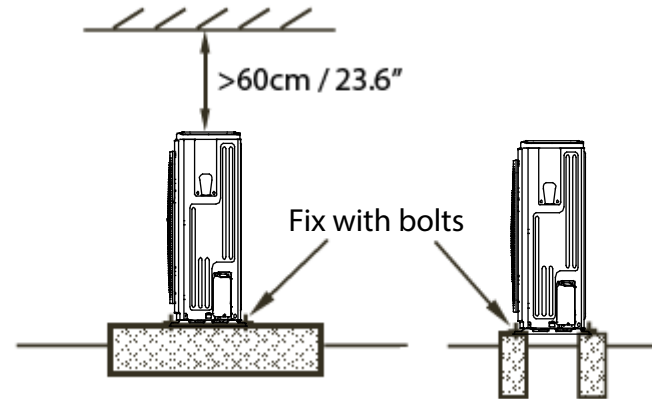

Caution

Since the gravity center of the unit is not at its physical center, so please be careful when lifting it with a sling.

Never hold the inlet of the outdoor unit to prevent it from deforming.

Do not touch the fan with hands or other objects.

Do not lean it more than 45°, and do not lay it sidelong.

Make concrete foundation according to the specifications of the outdoor units.

Fasten the feet of this unit with bolts firmly to prevent it from collapsing in case of earthquake or strong wind.

5. Drainage Pipe Installation

Install the drainage pipe as shown below and take measures against condensation. Improperly installation could lead to leakage and eventually wet furniture and belongings.

5.1 Installation principle

- Ensure at least 1/100 slope of the drainage pipe
- Adopt suitable pipe diameter
- Adopt nearby condensate water discharge

5.2 Key points of drainage water pipe installation

1. Considering the pipeline route and elevation.

- Before installing condensate water pipeline, determine its route and elevation to avoid intersection with other pipelines and ensure slope is straight.

2. Drainage pipe selection

- The drainage pipe diameter shall not small than the drain hose of indoor unit
- According to the water flowrate and drainage pipe slope to choose the suitable pipe, the water flowrate is decided by the capacity of indoor unit.

Relationship between water flowrate and capacity of indoor unit

Capacity (kBtu/h)	Water flowrate (l/h)
12	2.4
18	4
24	6
30	7
36	8
42	10
48	12
60	14

According to the above table to calculate the total water flowrate for the confluence pipe selection.

For horizontal drainage pipe (The following table is for reference)

PVC pipe	Reference value of inner diameter of pipe (mm)	Allowable maximum water flowrate (l/h)		Remark
		Slope 1/50	Slope 1/100	
PVC25	20	39	27	For branch pipe
PVC32	25	70	50	
PVC40	31	125	88	Could be used for confluence pipe
PVC50	40	247	175	
PVC63	51	473	334	

Attention: Adopt PVC40 or bigger pipe to be the main pipe.

For Vertical drainage pipe (The following table is for reference)

PVC pipe	Reference value of inner diameter of pipe (mm)	Allowable maximum water flowrate (l/h)	Remark
PVC25	20	220	For branch pipe
PVC32	25	410	
PVC40	31	730	Could be used for confluence pipe
PVC50	40	1440	
PVC63	51	2760	
PVC75	67	5710	
PVC90	77	8280	

Attention: Adopt PVC40 or bigger pipe to be the main pipe.

3. Individual design of drainage pipe system

- The drainage pipe of air conditioner shall be installed separately with other sewage pipe, rainwater pipe and drainage pipe in building.
- The drainage pipe of the indoor unit with water pump should be apart from the one without water pump.

4. Supporter gap of drainage pipe

- In general, the supporter gap of the drainage pipe horizontal pipe and vertical pipe is respectively 1m~1.5m and 1.5m~2.0m.
- Each vertical pipe shall be equipped with not less than two hangers.
- Overlarge hanger gap for horizontal pipe shall create bending, thus leading to air block.

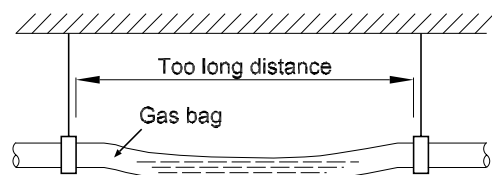

5. The horizontal pipe layout should avoid converse flow or bad flow

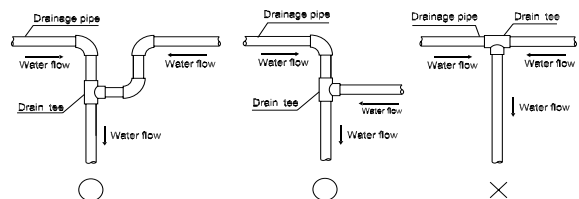

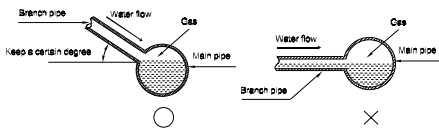

- The correct installation will not cause converse water flow and the slope of the branch pipes can be adjusted freely
- The false installation will cause converse water flow and the slope of the branch pipe can not be adjusted.

6. Water storage pipe setting

- If the indoor unit has high extra static pressure and without water pump to elevate the condensate water, such as high extra static pressure duct unit, the water storage pipe should be set to avoid converse flow or blow water phenomena.

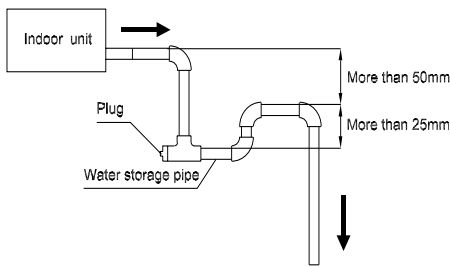

7. Lifting pipe setting of indoor unit with water pump

- The length of lifting pipe should not exceed 750mm/29.5in;

The drainage pipe should be set down inclined after the lifting pipe immediately to avoid wrong operation of water level switch.

- Refer the following picture for installation reference.

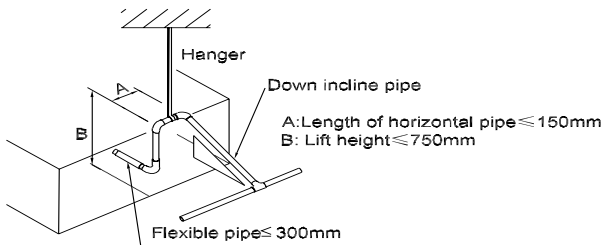

8. Blowhole setting

- For the concentrated drainage pipe system, there should design a blowhole at the highest point of main pipe to ensure the condensate water discharge smoothly.
- The air outlet shall face down to prevent dirt enter-

ing pipe.

- Each indoor unit of the system should be installed it.
- The installation should be considering the convenience for future cleaning.

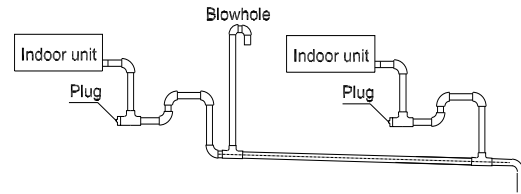

9. The end of drainage pipe shall not contact with ground directly.

5.3 Insulation work of drainage pipe

Refer the introduction to the insulation engineering parts.

6. Refrigerant Pipe Installation

6.1 Maximum length and drop height

Ensure that the length of the refrigerant pipe, the number of bends, and the drop height between the indoor and outdoor units meets the requirements shown in the following table.

For North America, Australia and Europe 3D Inverter models:

Capacity(kBtu/h)	Max. Length (m/ft)	Max. Elevation (m/ft)
<15	25/82	10/32.8
15-23	30/98.4	20/65.6
24~35	50/164	25/82
36~60	65/213.3	30/98.4

For other models:

Capacity(kBtu/h)	Max. Length (m/ft)	Max. Elevation (m/ft)
12	15/49	8/26
18-24	25/82	15/49
30-36	30/98.4	20/65.6
42~60	50/164	30/98.4

Caution:

1. The capacity test is based on the standard length and the maximum permissible length is based on the system reliability.

2. Oil traps

-If oil flows back into the outdoor unit's compressor, this might cause liquid compression or deterioration of oil return. Oil traps in the rising gas piping can prevent this.

-An oil trap should be installed every 6m(20ft) of vertical suction line riser (<36000Btu/h unit).

-An oil trap should be installed every 10m(32.8ft) of vertical suction line riser (≥36000Btu/h unit).

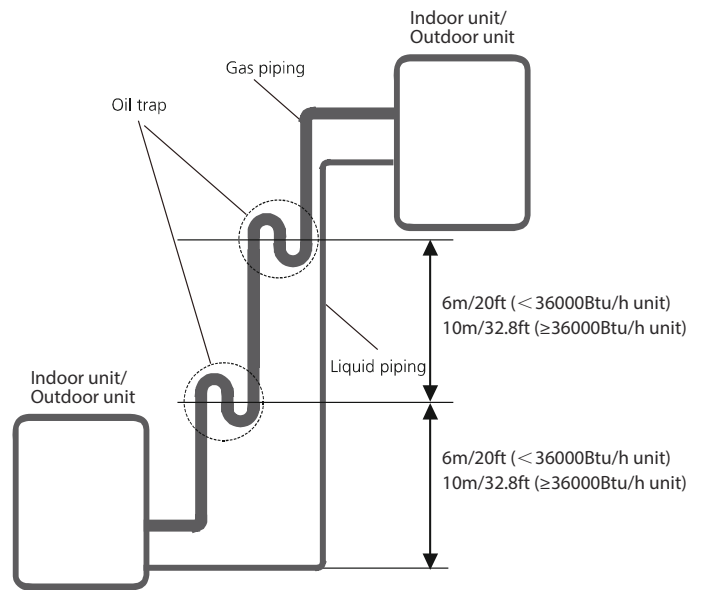

6.2 The procedure of connecting pipes

1. Choose the pipe size according to the specification table.
2. Confirm the cross way of the pipes.
3. Measure the necessary pipe length.
4. Cut the selected pipe with pipe cutter

- Make the section flat and smooth.

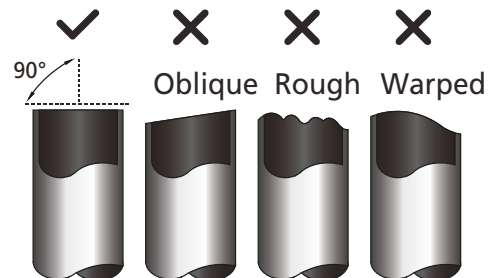

5. Insulate the copper pipe

- Before test operation, the joint parts should not be heat insulated.

6. Flare the pipe

- Insert a flare nut into the pipe before flaring the pipe
- According to the following table to flare the pipe.

Pipe diameter (inch(mm))	Flare dimension A (mm/inch)		Flare shape
	Min	Max	
1/4" (6.35)	8.4/0.33	8.7/0.34	
3/8" (9.52)	13.2/0.52	13.5/0.53	
1/2" (12.7)	16.2/0.64	16.5/0.65	
5/8" (15.9)	19.2/0.76	19.7/0.78	
3/4" (19)	23.2/0.91	23.7/0.93	
7/8" (22)	26.4/1.04	26.9/1.06	

- After flared the pipe, the opening part must be seal by end cover or adhesive tape to avoid duct or exogenous impurity come into the pipe.

7. Drill holes if the pipes need to pass the wall.

8. According to the field condition to bend the pipes so that it can pass the wall smoothly.

9. Bind and wrap the wire together with the insulated pipe if necessary.

10. Set the wall conduit

11. Set the supporter for the pipe.

12. Locate the pipe and fix it by supporter

- For horizontal refrigerant pipe, the distance between supporters should not be exceed 1m.
- For vertical refrigerant pipe, the distance between supporters should not be exceed 1.5m.

13. Connect the pipe to indoor unit and outdoor unit by using two spanners.

- Be sure to use two spanners and proper torque to fasten the nut, too large torque will damage the bellmouthing, and too small torque may cause leakage. Refer the following table for different pipe connection.

Pipe Diameter	Torque	Sketch map
	N.m(lb.ft)	
1/4" (6.35)	15~16 (11~11.8)	
3/8" (9.52)	25~26 (18.4~19.18)	
1/2" (12.7)	35~36 (25.8~26.55)	
5/8" (15.9)	45~47 (33.19~34.67)	
3/4" (19)	65~67 (47.94~49.42)	
7/8" (22)	75~85 (55.3~62.7)	

7. Vacuum Drying and Leakage Checking

7.1 Purpose of vacuum drying

- Eliminating moisture in system to prevent the phenomena of ice-blockage and copper oxidation. Ice-blockage shall cause abnormal operation of system, while copper oxide shall damage compressor.
- Eliminating the non-condensable gas (air) in system to prevent the components oxidizing, pressure fluctuation and bad heat exchange during the operation of system.

7.2 Selection of vacuum pump

- The ultimate vacuum degree of vacuum pump shall be -756mmHg or above.
- Precision of vacuum pump shall reach 0.02mmHg or above.

7.3 Operation procedure for vacuum drying

Due to different construction environment, two kinds of vacuum drying ways could be chosen, namely ordinary vacuum drying and special vacuum drying.

7.3.1 Ordinary vacuum drying

1. When conduct first vacuum drying, connect pressure gauge to the infusing mouth of gas pipe and liquid pipe, and keep vacuum pump running for 1 hour (vacuum degree of vacuum pump shall be reached -755mmHg).
2. If the vacuum degree of vacuum pump could not reach -755mmHg after 1 hour of drying, it indicates that there is moisture or leakage in pipeline system and need to go on with drying for half an hour.
3. If the vacuum degree of vacuum pump still could not reach -755mmHg after 1.5 hours of drying, check whether there is leakage source.
4. Leakage test: After the vacuum degree reaches -755mmHg, stop vacuum drying and keep the pressure for 1 hour. If the indicator of vacuum gauge does not go up, it is qualified. If going up, it indicates that there is moisture or leak source.

7.3.2 Special vacuum drying

The special vacuum drying method shall be adopted when:

1. Finding moisture during flushing refrigerant pipe.
2. Conducting construction on rainy day, because rain water might penetrated into pipeline.
3. Construction period is long, and rain water might penetrated into pipeline.

4. Rain water might penetrate into pipeline during construction.

Procedures of special vacuum drying are as follows:

1. Vacuum drying for 1 hour.
2. Vacuum damage, filling nitrogen to reach 0.5Kgf/cm².

Because nitrogen is dry gas, vacuum damage could achieve the effect of vacuum drying, but this method could not achieve drying thoroughly when there is too much moisture. Therefore, special attention shall be drawn to prevent the entering of water and the formation of condensate water.

3. Vacuum drying again for half an hour.

If the pressure reached -755mmHg, start to pressure leakage test. If it cannot reached the value, repeat vacuum damage and vacuum drying again for 1 hour.

4. Leakage test: After the vacuum degree reaches -755mmHg, stop vacuum drying and keep the pressure for 1 hour. If the indicator of vacuum gauge does not go up, it is qualified. If going up, it indicates that there is moisture or leak source.

8. Additional Refrigerant Charge

- After the vacuum drying process is carried out, the additional refrigerant charge process need to be performed.
- The outdoor unit is factory charged with refrigerant. The additional refrigerant charge volume is decided by the diameter and length of the liquid pipe between indoor and outdoor unit. Refer the following formula to calculate the charge volume.

	Diameter of liquid pipe (mm(inch))	Formula
R22/ R410A(Throttling part in the indoor unit)	6.35(1/4)	$V=30(0.32)g/m(oz/ft) \times (L - \text{standard pipe length})$
	9.52(3/8)	$V=65(0.69)g/m(oz/ft) \times (L - \text{standard pipe length})$
	12.7(1/2)	$V=115(1.23)g/m(oz/ft) \times (L - \text{standard pipe length})$
R22(Throttling part in the outdoor unit)	6.35(1/4)	$V=15(0.16)g/m(oz/ft) \times (L - \text{standard pipe length})$
	9.52(3/8)	$V=30(0.32)g/m(oz/ft) \times (L - \text{standard pipe length})$
	12.7(1/2)	$V=60(0.64)g/m(oz/ft) \times (L - \text{standard pipe length})$
R410A(Throttling part in the outdoor unit)	6.35(1/4)	$V=15(0.16)g/m(oz/ft) \times (L - \text{standard pipe length})$
	9.52(3/8)	$V=30(0.32)g/m(oz/ft) \times (L - \text{standard pipe length})$
	12.7(1/2)	$V=65(0.69)g/m(oz/ft) \times (L - \text{standard pipe length})$
R32	6.35(1/4)	$V=12(0.13)g/m(oz/ft) \times (L - \text{standard pipe length})$
	9.52(3/8)	$V=24(0.26)g/m(oz/ft) \times (L - \text{standard pipe length})$
	12.7(1/2)	$V=40(0.42)g/m(oz/ft) \times (L - \text{standard pipe length})$

V: Additional refrigerant charge volume.

L : The length of the liquid pipe.

Note:

- Refrigerant may only be charged after performed the vacuum drying process.
- Always use gloves and glasses to protect your hands and eyes during the charge work.
- Use electronic scale or fluid infusion apparatus to weight refrigerant to be recharged. Be sure to avoid extra refrigerant charged, it may cause liquid hammer of the compressor or protections.
- Use supplementing flexible pipe to connect refrigerant cylinder, pressure gauge and outdoor unit. And The refrigerant should be charged in liquid state. Before recharging, The air in the flexible pipe and manifold gauge should be exhausted.
- After finished refrigerant recharge process, check whether there is refrigerant leakage at the connection joint part.(Using gas leakage detector or soap water to detect).

9 . Engineering of Insulation

9.1 Insulation of refrigerant pipe

1. Operational procedure of refrigerant pipe insulation

Cut the suitable pipe → insulation (except joint section) → flare the pipe → piping layout and connection → vacuum drying → insulate the joint parts

2. Purpose of refrigerant pipe insulation

- During operation, temperature of gas pipe and liquid pipe shall be over-heating or over-cooling extremely. Therefore, it is necessary to carry out insulation; otherwise it shall debase the performance of unit and burn compressor.
- Gas pipe temperature is very low during cooling. If insulation is not enough, it shall form dew and cause leakage.
- Temperature of gas pipe is very high (generally 50-100 °C) during heating. Insulation work must be carried out to prevent hurt by carelessness touching.

3. Insulation material selection for refrigerant pipe

- The burning performance should over 120 °C
- According to the local law to choose insulation materials
- The thickness of insulation layer shall be above 10mm. If in hot or wet environment place, the layer of insulation should be thicker accordingly.

4. Installation highlights of insulation construction

- Gas pipe and liquid pipe shall be insulated separately, if the gas pipe and liquid pipe were insulated together; it will decrease the performance of air conditioner.

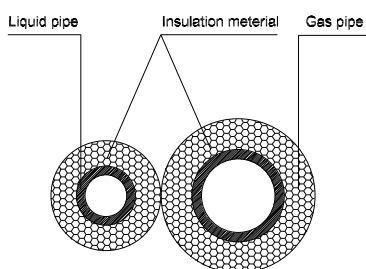

- The insulation material at the joint pipe shall be 5~10cm longer than the gap of the insulation material.
- The insulation material at the joint pipe shall be inserted into the gap of the insulation material.
- The insulation material at the joint pipe shall be banded to the gap pipe and liquid pipe tightly.
- The linking part should be use glue to paste together
- Be sure not bind the insulation material over-tight, it may extrude out the air in the material to cause bad

insulation and cause easy aging of the material.

9.2 Insulation of drainage pipe

1. Operational procedure of refrigerant pipe insulation

Select the suitable pipe → insulation (except joint section) → piping layout and connection → drainage test → insulate the joint parts

2. Purpose of drainage pipe insulation

The temperature of condensate drainage water is very low. If insulation is not enough, it shall form dew and cause leakage to damage the house decoration.

3. Insulation material selection for drainage pipe

- The insulation material should be flame retardant material, the flame retardancy of the material should be selected according to the local law.
- Thickness of insulation layer is usually above 10mm.
- Use specific glue to paste the seam of insulation material, and then bind with adhesive tape. The width of tape shall not be less than 5cm. Make sure it is firm and avoid dew.

4. Installation and highlights of insulation construction

- The single pipe should be insulated before connecting to another pipe, the joint part should be insulated after the drainage test.
- There should be no insulation gap between the insulation material.

10. Engineering of Electrical Wiring

1. Highlights of electrical wiring installation

- All field wiring construction should be finished by qualified electrician.
- Air conditioning equipment should be grounded according to the local electrical regulations.
- Current leakage protection switch should be installed.
- Do not connect the power wire to the terminal of signal wire.
- When power wire is parallel with signal wire, put wires to their own wire tube and remain at least 300mm gap.
- According to table in indoor part named "the specification of the power" to choose the wiring, make sure the selected wiring not small than the date showing in the table.
- Select different colors for different wire according to relevant regulations.
- Do not use metal wire tube at the place with acid or alkali corrosion, adopt plastic wire tube to replace it.
- There must be not wire connect joint in the wire tube If joint is a must, set a connection box at the place.
- The wiring with different voltage should not be in one wire tube.
- Ensure that the color of the wires of outdoor and the terminal No. are same as those of indoor unit respectively.

Table: Minimum Cross-Sectional Area of Power and Signal Cables

For North America:

Rated Current of Appliance (A)	AWG
≤ 6	18
6 - 10	16
10 - 16	14
16 - 25	12
25 - 32	10

For the other regions:

Rated Current of Appliance (A)	Nominal Cross-Sectional Area(mm ²)
≤ 6	0.75
6 - 10	1
10 - 16	1.5
16 - 25	2.5
25 - 32	4
32 - 45	6

11. Test Operation

1. The test operation must be carried out after the entire installation has been completed.

2. Please confirm the following points before the test operation.

- The indoor unit and outdoor unit are installed properly.
- Piping and wiring are properly connected.
- Ensure that there are no obstacles near the inlet and outlet of the unit that might cause poor performance or product malfunction.
- The refrigeration system does not leak.
- The drainage system is unimpeded and draining to a safe location.
- The heating insulation is properly installed.
- The grounding wires are properly connected
- The length of the piping and the added refrigerant stow capacity have been recorded.
- The power voltage is the correct voltage for the air conditioner.

CAUTION: Failure to perform the test run may result in unit damage, property damage or personal injury.

3. Test Run Instructions

1. Open both the liquid and gas stop valves.
2. Turn on the main power switch and allow the unit to warm up.
3. Set the air conditioner to COOL mode, and check the following points.

Indoor unit

- Whether the switch on the remote controller works well.
- Whether the buttons on the remote controller works well.
- Whether the air flow louver moves normally.
- Whether the room temperature is adjusted well.
- Whether the indicator lights normally.
- Whether the temporary buttons works well.
- Whether the drainage is normal.
- Whether there is vibration or abnormal noise during operation.

Outdoor unit

- Whether there is vibration or abnormal noise during operation.
- Whether the generated wind, noise, or condensed of by the air conditioner have influenced your neighborhood.
- Whether any of the refrigerant is leaked.

4. Drainage Test

- a. Ensure the drainpipe flow smoothly. New buildings should perform this test before finishing the ceiling.
- b. Remove the test cover. Add 2000ml of water to the tank through the attached tube.
- c. Turn on the main power switch and run the air conditioner in COOL mode.
- d. Listen to the sound of the drain pump to see if it makes any unusual noises.
- e. Check to see that the water is discharged. It may take up to one minute before the unit begins to drain depending on the drainpipe.
- f. Make sure that there are no leaks in any of the piping.
- g. Stop the air conditioner. Turn off the main power switch and reinstall the test cover.

Maintenance

Contents

1.	First Time Installation Check	2
2	Refrigerant Recharge	4
3	Re-Installation	5
3.1	Indoor Unit.....	5
3.2	Outdoor Unit.....	7

1. First Time Installation Check

Air and moisture trapped in the refrigerant system affects the performance of the air conditioner by:

- Increasing pressure in the system.
- Increasing the operating current.
- Decreasing the cooling or heating efficiency.
- Congesting the capillary tubing due to ice build-up in the refrigerant circuit.
- Corroding the refrigerant system.

To prevent air and moisture from affecting the air conditioner's performance, the indoor unit, as well as the pipes between the indoor and outdoor unit, must be leak tested and evacuated.

Leak test (soap water method)

Use a soft brush to apply soapy water or a neutral liquid detergent onto the indoor unit connections and outdoor unit connections. If there is gas leakage, bubbles will form on the connection.

Air purging with vacuum pump

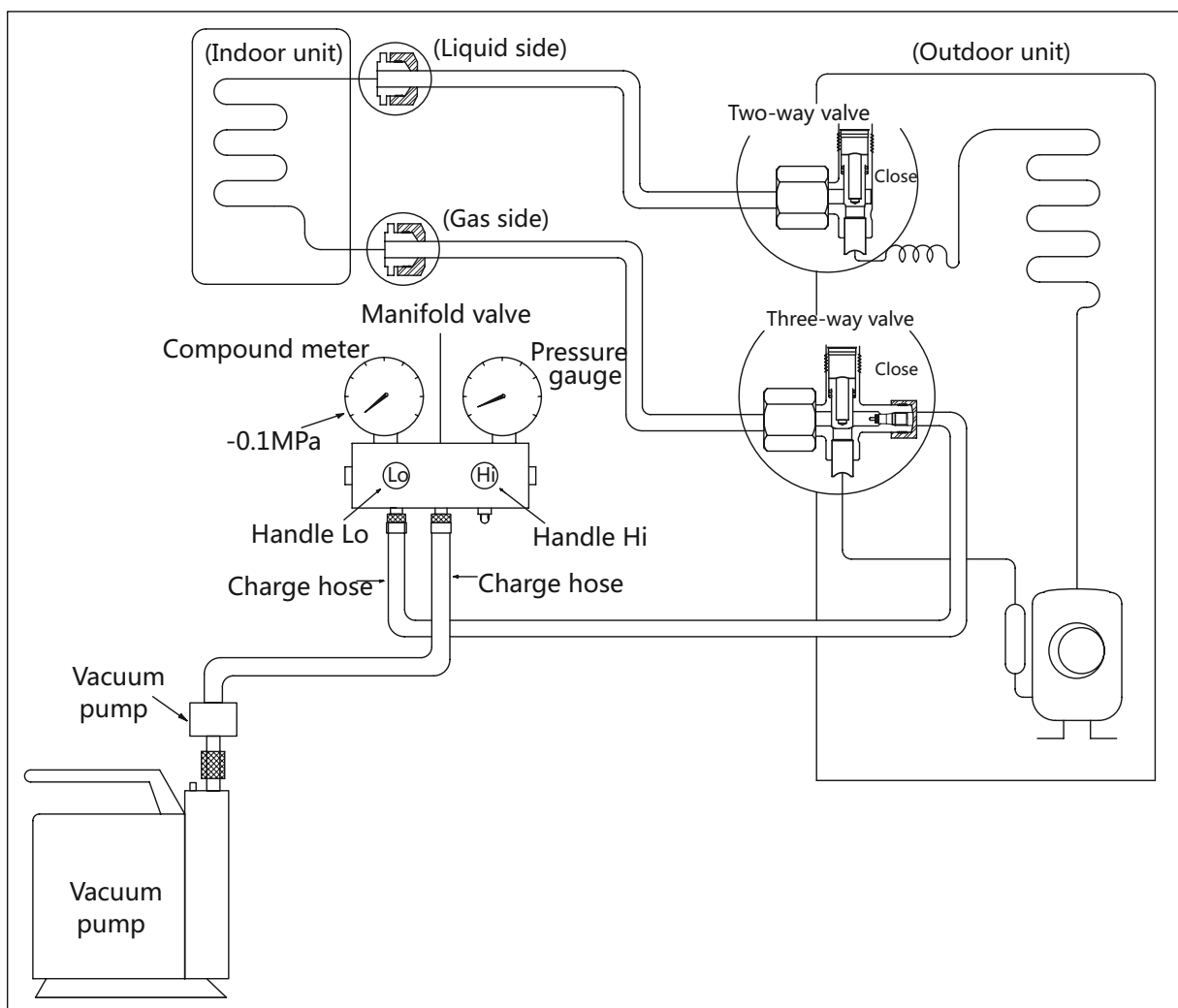

Procedure:

1. Tighten the flare nuts of the indoor and outdoor units, and confirm that both the 2- and 3-way valves are closed.
2. Connect the charge hose with the push pin of Handle Lo to the gas service port of the 3-way valve.
3. Connect another charge hose to the vacuum pump.
4. Fully open the Handle Lo manifold valve.
5. Using the vacuum pump, evacuate the system for 30 minutes.
 - a. Check whether the compound meter indicates -0.1 MPa (14.5 Psi).
 - If the meter does not indicate -0.1 MPa (14.5 Psi) after 30 minutes, continue evacuating for an additional 20 minutes.
 - If the pressure does not achieve -0.1 MPa (14.5 Psi) after 50 minutes, check for leakage.
6. Loosen the flare nut of the 3-way valve for 6 or 7 seconds and then tighten the flare nut again.
 - a. Confirm the pressure display in the pressure indicator is slightly higher than the atmospheric pressure.
 - b. Remove the charge hose from the 3-way valve.
7. Fully open the 2- and 3-way valves and tighten the cap of the 2- and 3-way valves.
 - If the pressure successfully reaches -0.1 MPa (14.5 Psi), fully close the Handle Lo valve, then cease vacuum pump operations.
8. Wait for 5 minutes then check whether the gauge needle moves after turning off the vacuum pump. If the gauge needle moves backward, check whether there is gas leakage.

2. Refrigerant Recharge

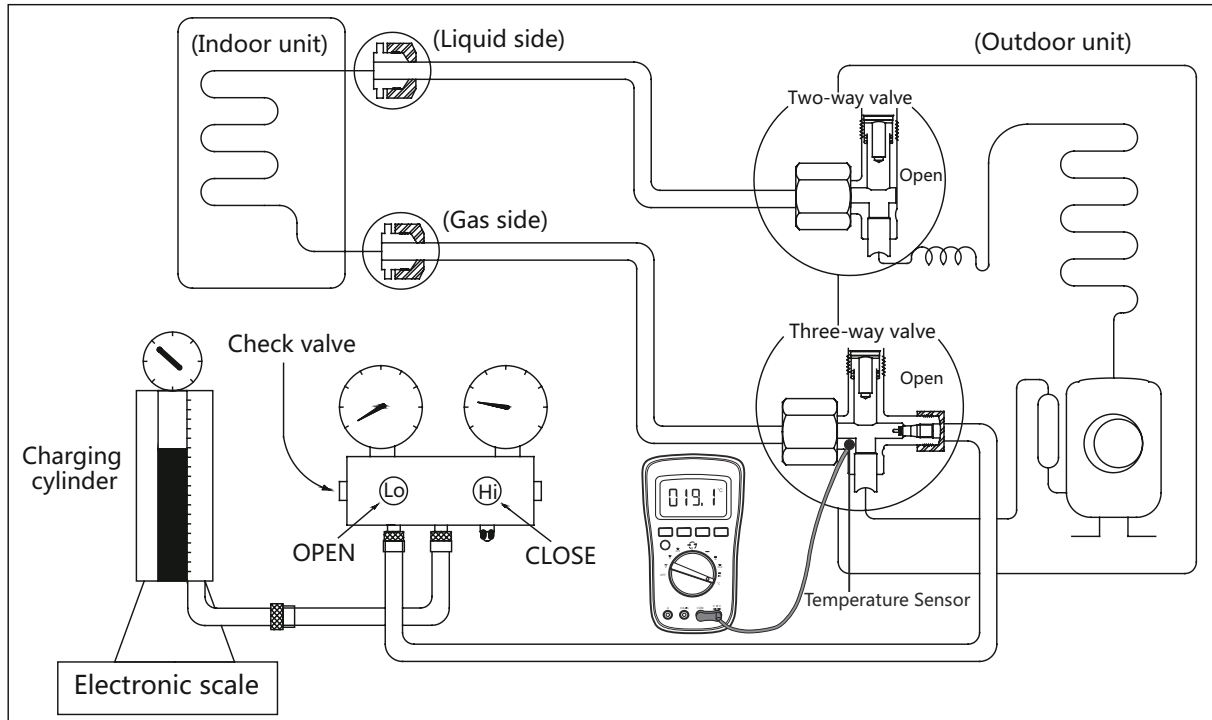

Procedure:

1. Close both 2- and 3-way valves.
2. Slightly connect the Handle Lo charge hose to the 3-way service port.
3. Connect the charge hose to the valve at the bottom of the cylinder.
4. If the refrigerant is R410A/R32, invert the cylinder to ensure a complete liquid charge.
5. Open the valve at the bottom of the cylinder for 5 seconds to purge the air in the charge hose, then fully tighten the charge hose with push pin Handle Lo to the service port of 3-way valve..
6. Place the charging cylinder onto an electronic scale and record the starting weight.
7. Fully open the Handle Lo manifold valve, 2- and 3-way valves.
8. Operate the air conditioner in cooling mode to charge the system with liquid refrigerant.
9. When the electronic scale displays the correct weight (refer to the gauge and the pressure of the low side to confirm, the value of pressure refers to chapter Appendix), turn off the air conditioner, then disconnect the charge hose from the 3-way service port immediately..
10. Mount the caps of service port and 2- and 3-way valves.
11. Use a torque wrench to tighten the caps to a torque of 18 N.m.
12. Check for gas leakage.

3. Re-Installation

3.1 Indoor Unit

Collecting the refrigerant into the outdoor unit

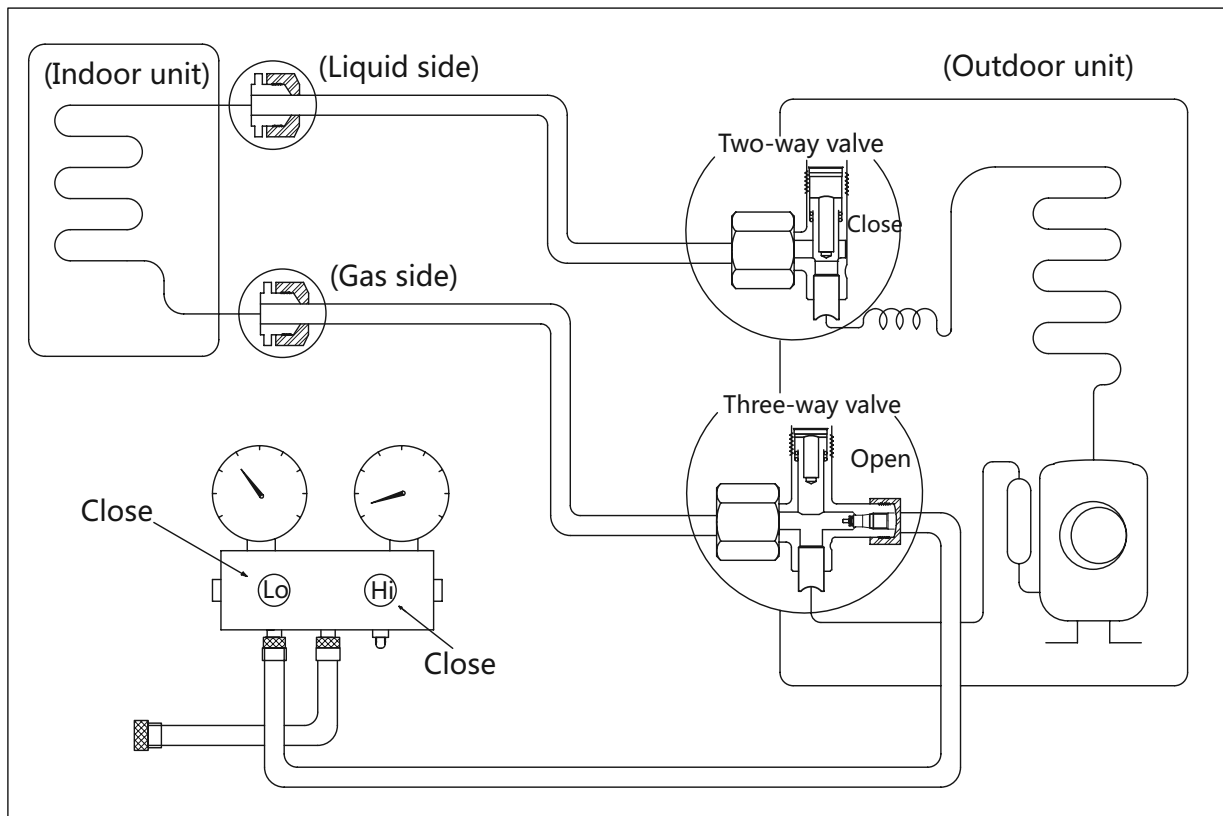

Procedure:

1. Confirm that the 2- and 3-way valves are opened.
2. Connect the charge hose with the push pin of Handle Lo to the 3-way valve's gas service port.
3. Open the Handle Lo manifold valve to purge air from the charge hose for 5 seconds and then close it quickly.
4. Close the 2-way valve.
5. Operate the air conditioner in cooling mode. Cease operations when the gauge reaches 0.1 MPa (14.5 Psi).
6. Close the 3-way valve so that the gauge rests between 0.3 MPa (43.5 Psi) and 0.5 MPa (72.5 Psi).
7. Disconnect the charge set and mount the caps of service port and 2- and 3-way valves.
8. Use a torque wrench to tighten the caps to a torque of 18 N.m.
9. Check for gas leakage.

Air purging with vacuum pump

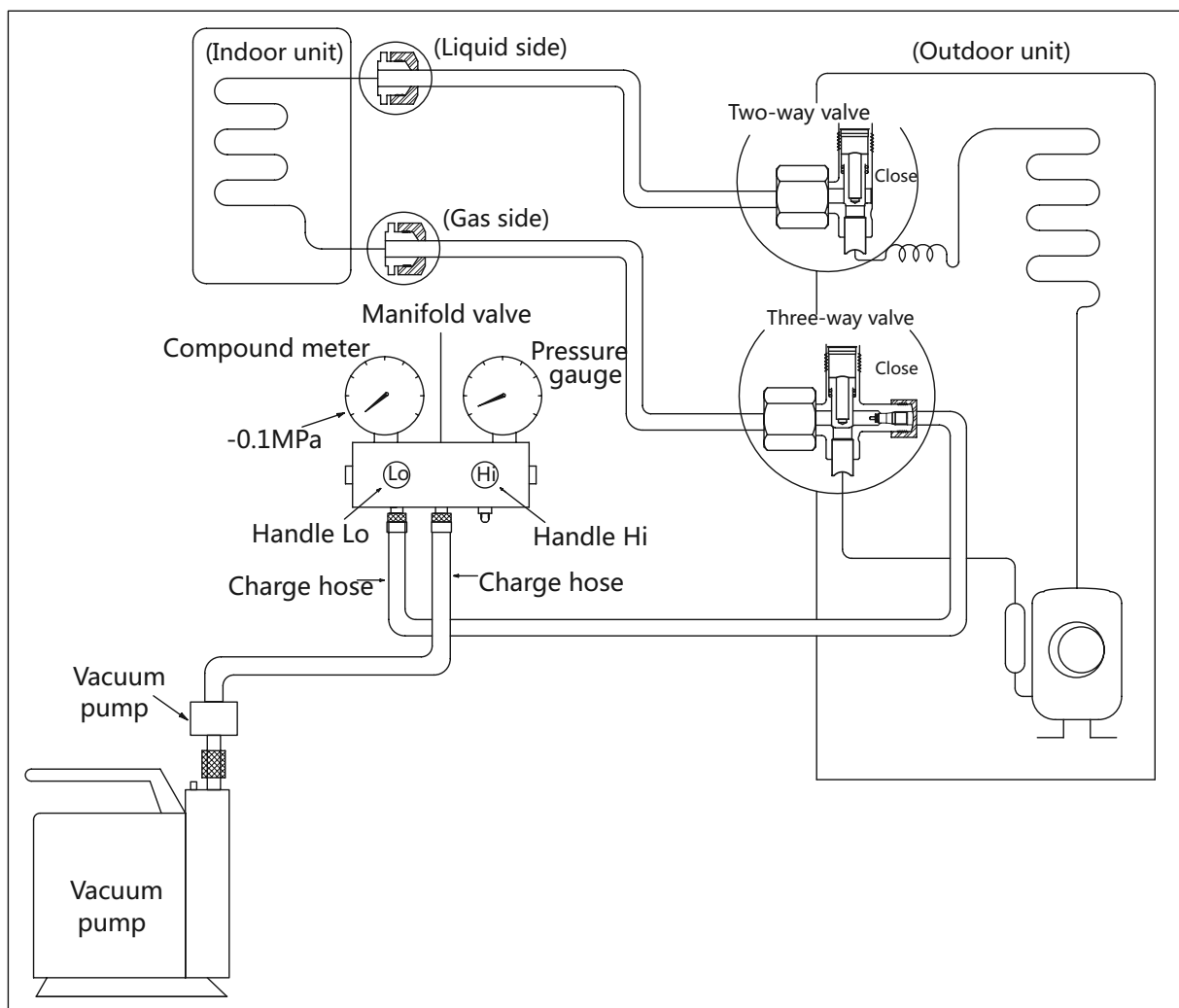

Procedure:

1. Tighten the flare nuts of the indoor and outdoor units, and confirm that both the 2- and 3-way valves are closed.
2. Connect the charge hose with the push pin of Handle Lo to the gas service port of the 3-way valve.
3. Connect another charge hose to the vacuum pump.
4. Fully open the Handle Lo manifold valve.
5. Using the vacuum pump, evacuate the system for 30 minutes.
 - a. Check whether the compound meter indicates -0.1 MPa (14.5 Psi).
 - If the meter does not indicate -0.1 MPa (14.5 Psi) after 30 minutes, continue evacuating for an additional 20 minutes.
 - If the pressure does not achieve -0.1 MPa (14.5 Psi) after 50 minutes, check for leakage.
 - b. If the pressure successfully reaches -0.1 MPa (14.5 Psi), fully close the Handle Lo valve, then cease vacuum pump operations.
6. Loosen the flare nut of the 3-way valve for 6 or 7 seconds and then tighten the flare nut again.
 - a. Confirm the pressure display in the pressure indicator is slightly higher than the atmospheric pressure.
 - b. Remove the charge hose from the 3-way valve.
7. Fully open the 2- and 3-way valves and tighten the cap of the 2- and 3-way valves.

3.2 Outdoor Unit

Evacuation for the whole system

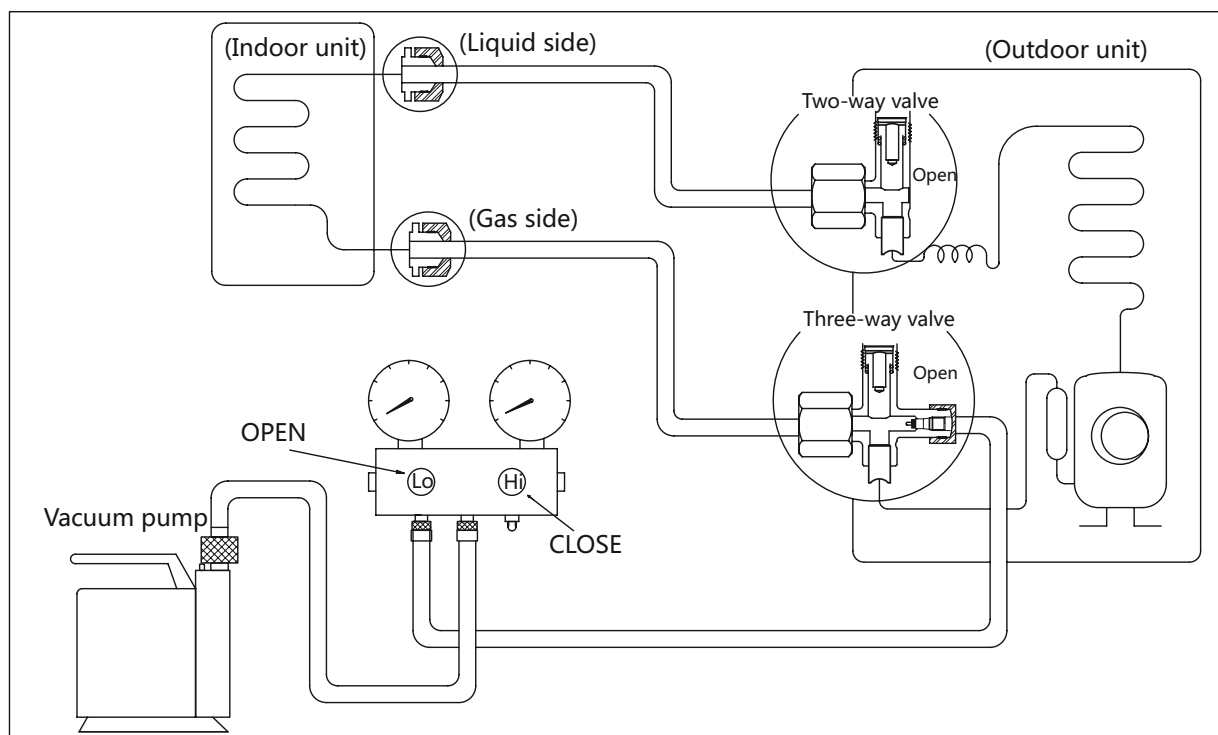

Procedure:

1. Confirm that the 2- and 3-way valves are opened.
2. Connect the vacuum pump to the 3-way valve's service port.
3. Evacuate the system for approximately one hour. Confirm that the compound meter indicates -0.1 MPa (14.5Psi).
4. Close the valve (Low side) on the charge set and turn off the vacuum pump.
5. Wait for 5 minutes then check whether the gauge needle moves after turning off the vacuum pump. If the gauge needle moves backward, check whether there is gas leakage.
6. Disconnect the charge hose from the vacuum pump.
7. Mount the caps of service port and 2- and 3-way valves.
8. Use a torque wrench to tighten the caps to a torque of 18 N.m.

Refrigerant charging

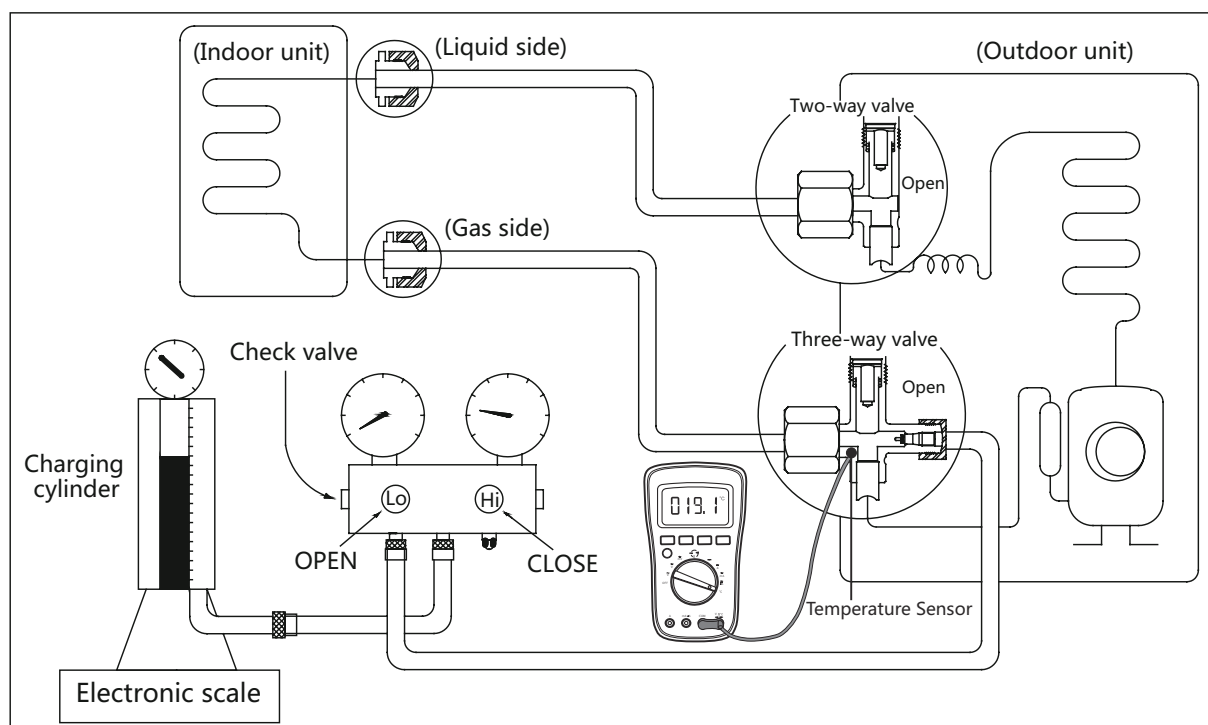

Procedure:

1. Close both 2- and 3-way valves.
2. Slightly connect the Handle Lo charge hose to the 3-way service port.
3. Connect the charge hose to the valve at the bottom of the cylinder.
4. If the refrigerant is R410A/R32, invert the cylinder to ensure a complete liquid charge.
5. Open the valve at the bottom of the cylinder for 5 seconds to purge the air in the charge hose, then fully tighten the charge hose with push pin Handle Lo to the service port of 3-way valve..
6. Place the charging cylinder onto an electronic scale and record the starting weight.
7. Fully open the Handle Lo manifold valve, 2- and 3-way valves.
8. Operate the air conditioner in cooling mode to charge the system with liquid refrigerant.
9. When the electronic scale displays the correct weight (refer to the gauge and the pressure of the low side to confirm, the value of pressure refers to chapter Appendix), turn off the air conditioner, then disconnect the charge hose from the 3-way service port immediately..
10. Mount the caps of service port and 2- and 3-way valves.
11. Use a torque wrench to tighten the caps to a torque of 18 N.m.
12. Check for gas leakage.

Note: 1. Mechanical connectors used indoors shall comply with local regulations.

2. When mechanical connectors are reused indoors, sealing parts shall be renewed. When flared joints are reused indoors, the flare part shall be re-fabricated.

Product Features

Contents

1.	Display Function	2
2	Safety Features	5
3.	Basic Functions.....	6
3.1	Table	6
3.2	Abbreviation.....	7
3.3	Fan Mode.....	7
3.4	Cooling Mode	7
3.5	Heating Mode(Heat Pump Units)	7
3.6	Drying Mode	8
3.7	Auto-Restart Function.....	8

1. Display Function

Floor Ceiling Type

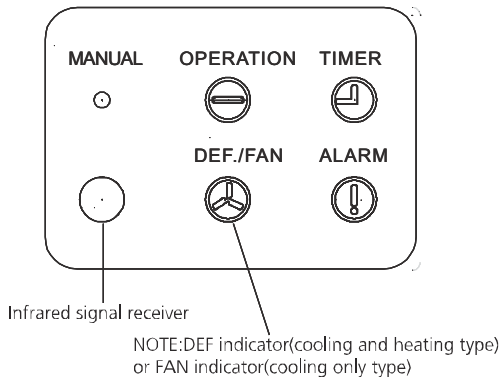

Display 1

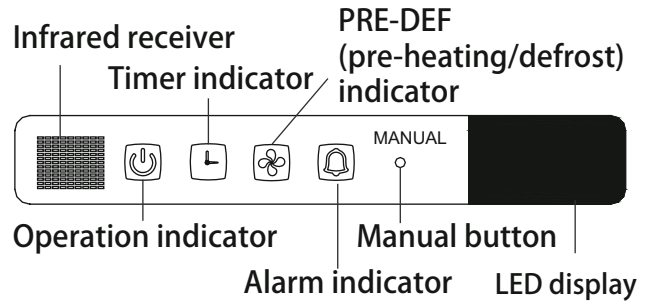

Display 2

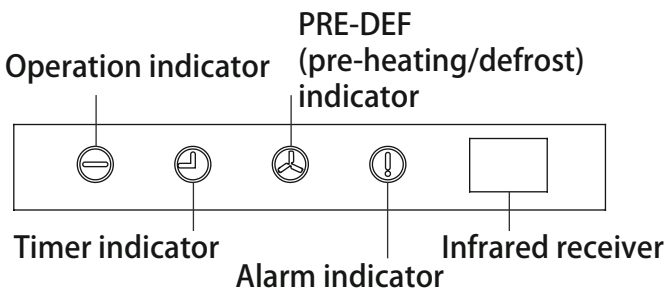

Display 3

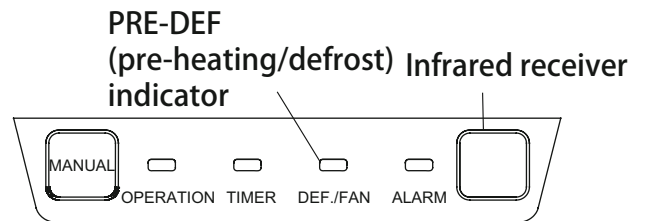

Display 4

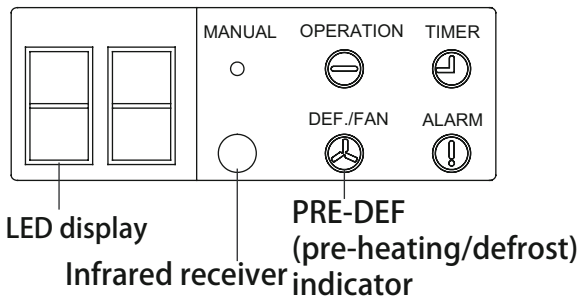

Display 5

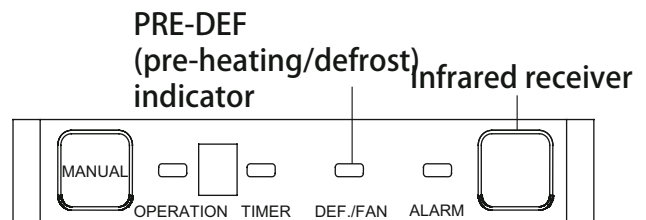

Display 6

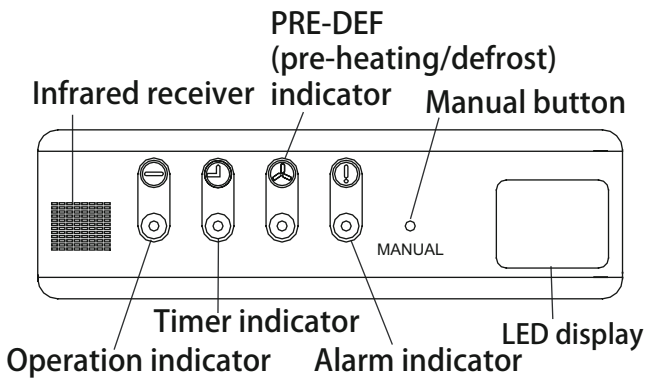

Display 7

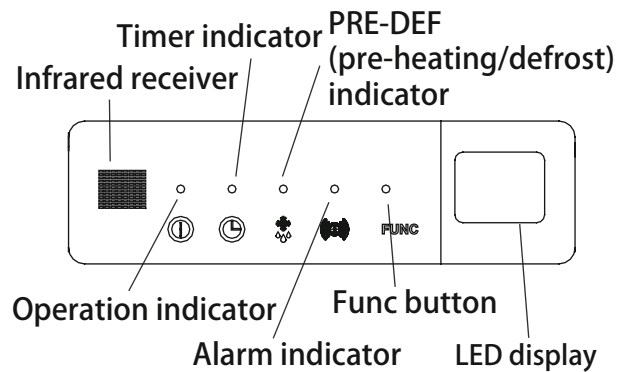

Display 8

Super-slim Cassette Type

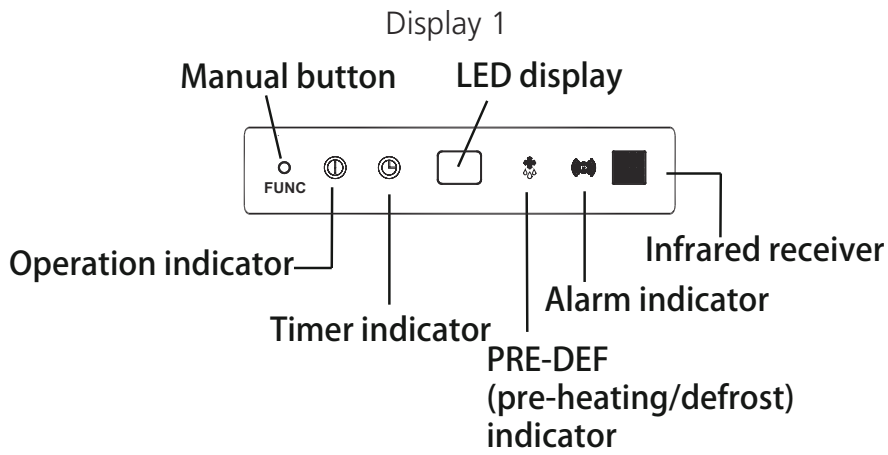
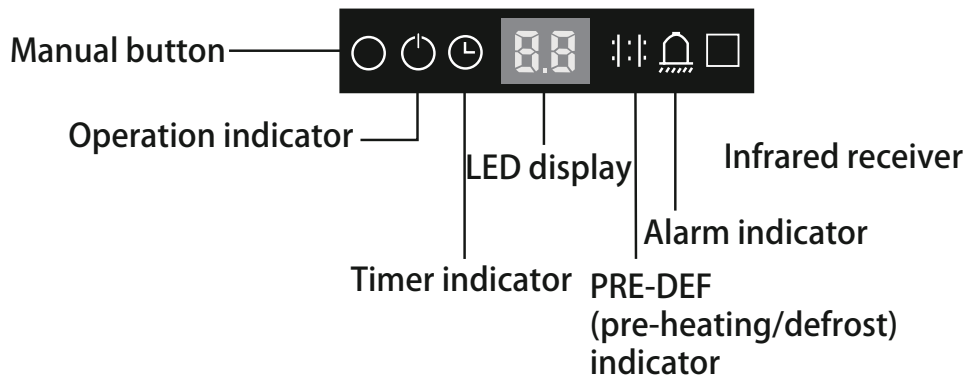

Display 2

Duct Type

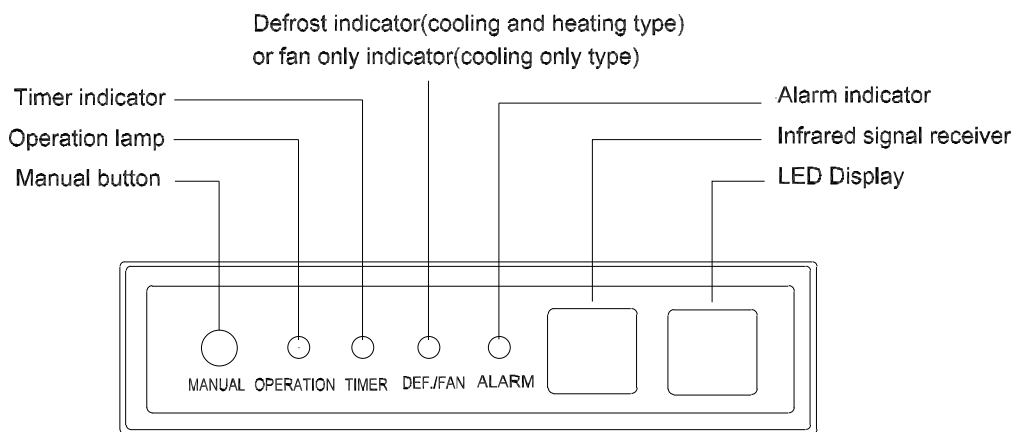

Compact Cassette Type

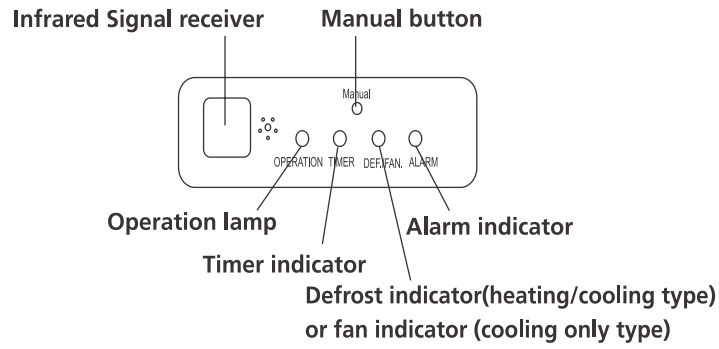

Console Type

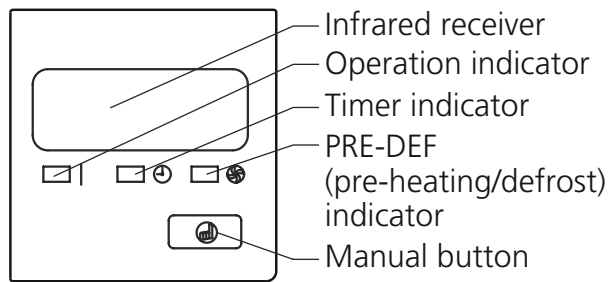

Display 1

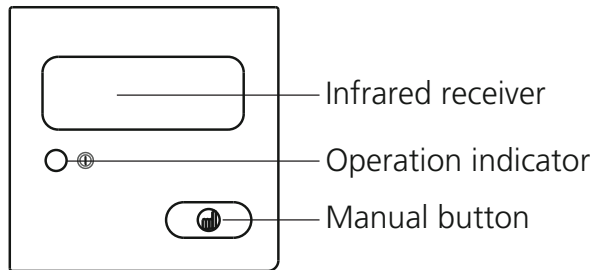

Display 2

Note: Please select the display function according to your purchase product.

2. Safety Features

Compressor three-minute delay at restart

Compressor functions are delayed for up to three minutes upon subsequent unit starts.

Automatic shutoff based on discharge temperature

If the compressor discharge temperature exceeds a certain level for nine seconds, the compressor ceases operation.

Automatic shutoff based on fan speed (for DC Fan Unit)

For Duct type:

If a fault occurs on the air volume regulator or the regulator enters protection mode, it sends the error message CF and an instruction to reduce fan speed to the master. The message and the instruction can be inquired with the remote controller or the wired controller. (Fault and protection information are displayed for one minute). After a fault occurs, the master unit shows the error code E3 and the fault count for one minute. If the fault occurs three times, then the fan is unable to resolve the problem independently. External shutdown by a remote controller, wired controller, or central controller must be used to clear the fan fault and fault count. The fan runs normally for 5 minutes while clearing fault count.

0	No malfunction
1	P0 Overcurrent
2	Overpressure
3	Overload
4	Over speed
5	Startup malfunction
6	Lack of phase
7	DC voltage too low
8	Communication fault
9	Parameter fault
10	L3 Current limited
11	L5 Voltage limited
12	Target speed cannot be met during the static pressure calculation process

For other types

If the indoor fan speed registers below 300 RPM for 50 seconds or more, it shuts off and restarts in 30 seconds. If this happens 3 times, the unit ceases operation and the LED displays the failure code

Inverter module protection

The inverter module has an automatic shutoff mechanism based on the unit's current, voltage, and temperature. If automatic shutoff is initiated, the corresponding error code is displayed on the indoor unit and the unit ceases operation.

Indoor fan delayed operation

- When the unit starts, the louver is automatically activated and the indoor fan will operate after a period of setting time or the louver is in place.
- If the unit is in heating mode, the indoor fan is regulated by the anti-cold wind function.

Compressor preheating

Preheating is automatically activated when T4 sensor is lower than setting temperature.

Sensor redundancy and automatic shutoff

- If one temperature sensor malfunctions, the air conditioner continues operation and displays the corresponding error code, allowing for emergency use.
- When more than one temperature sensor is malfunctioning, the air conditioner ceases operation.

3. Basic Functions

3.1 Table

Functions		Cooling Mode&Heating mode		Heating Mode			
		Outdoor Fan Control		Defrosting Mode		Anti-cold Air Function	
Cases		Case 1: Compressor Frequency and T4	Case 2:T4	Case 1:T3 and T4,15 min	Case 2: T3,10 min	Case 1	Case 2
Models	MVB-24HWFN1-M+MOD31-24HFN1-MT0W or MOD30-24HFN1-MT0W		✓		✓	✓	
	MVB-24HWFN1-M+MOD01-23HFN1-MT0W or MOD30-24HFN1-MU0W	✓		✓		✓	
	MVB-36HWFN1-M	✓		✓			✓
	MVB-48HWFN1-M		✓		✓		✓

Note: The detailed description of case 1 or case 2 is shown in the following function sections(from 3.4 to 3.5).

3.2 Abbreviation

Unit element abbreviations

Abbreviation	Element
T1	Indoor room temperature
T2	Coil temperature of evaporator
T3	Coil temperature of condenser
T4	Outdoor ambient temperature
TS	Set temperature
Td	Control target temperature
TP	Compressor discharge temperature

In this manual, such as TCE1, TCE2...etc., they are well-setting parameter of EEPROM.

3.3 Fan Mode

When fan mode is activated:

- The outdoor fan and compressor are stopped.
- Temperature control is disabled and no temperature setting is displayed.
- The indoor fan speed can be set to high, medium, low, or auto.
- The louver operations are identical to those in cooling mode.
- Auto fan: In fan-only mode, AC operates the same as auto fan in cooling mode with the temperature set at 24°C(75.2°F).

3.4 Cooling Mode

3.4.1 Indoor Fan Control

- In cooling mode, the indoor fan operates continuously. The fan speed can be set to high, medium, low, or auto.
- If the compressor ceases operation when the configured temperature is reached, the indoor fan motor operates at the minimum or configured speed.
- The indoor fan is controlled as below:

Setting fan speed	T1-Td (°C/°F)	Actual fan speed
H	A	H+ (H+=H+G)
	B	H (=H)
	C	H- (H-=H-G)
M	D	M+ (M+=M+Z)
	E	M (M=M)
	F	M- (M-=M-Z)
L	G	L+ (L+=L+D)
	H	L (L=L)
	I	L- (L-=L-D)

- The auto fan acts as below rules:

For DC Fan Unit:

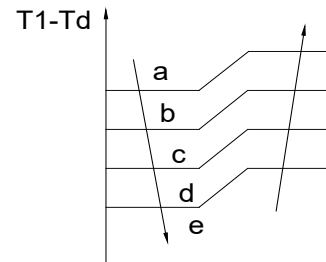

For AC Fan Unit:

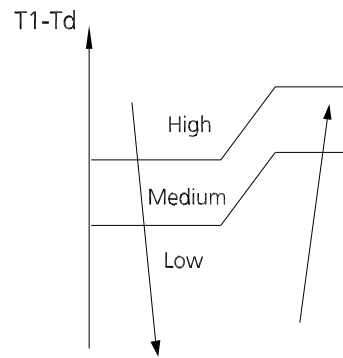

3.4.3 Outdoor Fan Control

Case 1:

- The outdoor unit will be run at different fan speed according to T4 and compressor frequency.
- For different outdoor units, the fan speeds are different.

Case 2:

- The outdoor unit will be run at different fan speed according to T4.
- For different outdoor units, the fan speeds are different.

3.4.4 Condenser Temperature Protection

When condenser temperature is more than setting value, the compressor ceases operation..

3.4.5 Evaporator Temperature Protection

When evaporator temperature drops below a configured value, the compressor and outdoor fan cease operation.

3.5 Heating Mode(Heat pump units)

3.5.1 Indoor Fan Control:

- When the compressor is on, the indoor fan speed can be set to high, medium, low, or auto. And the anti-cold wind function has the priority.

- Anti-cold air function
 - The indoor fan is controlled by indoor unit coil temperature T2.

For DC Fan Unit:

Case 1:

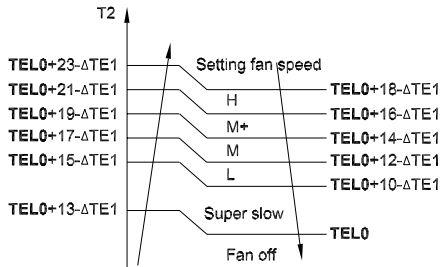

$T1 \geq 19^{\circ}\text{C}(66.2^{\circ}\text{F})$	$\Delta\text{TE}1=0$
$15^{\circ}\text{C}(59^{\circ}\text{F}) \leq T1 \leq 18^{\circ}\text{C}(64.4^{\circ}\text{F})$	$\Delta\text{TE}1=19^{\circ}\text{C}-T1$ ($34.2^{\circ}\text{F}-T1$)
$T1 < 15^{\circ}\text{C}(59^{\circ}\text{F})$	$\Delta\text{TE}1=4^{\circ}\text{C}(7.2^{\circ}\text{F})$

Case 2:

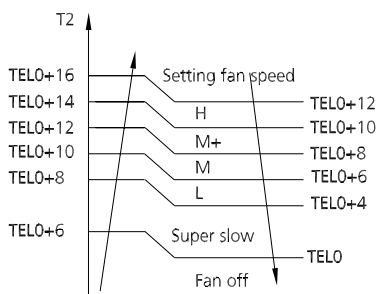

Case 3:

For AC Fan Unit:

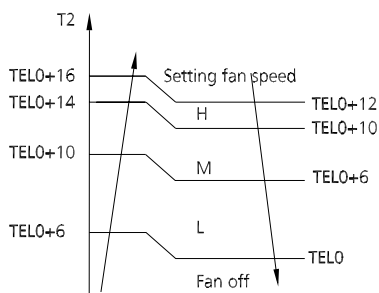

- When the indoor temperature T1 reaches the setting temperature, the compressor continues operation, the indoor fan motor runs at the minimum speed or setting speed.(The anti-cold air function is valid).
- The indoor fan is controlled as below:

Setting fan speed	T1-Td(°F)	Actual fan speed
H		H (H=H-G)
		H (=H)
		H+(H=H+G)
M		M(M=M-Z)
		M(M=M)
		M+(M=M+Z)
L		L(L=L-D)
		L(L=L)
		L+(L=L+D)

- Auto fan action in heating mode:

For DC Fan Unit:

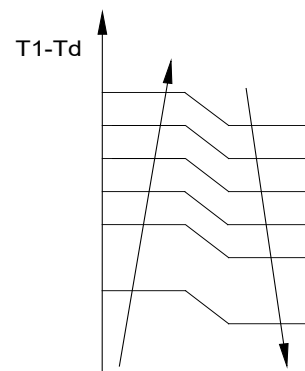

For AC Fan Unit:

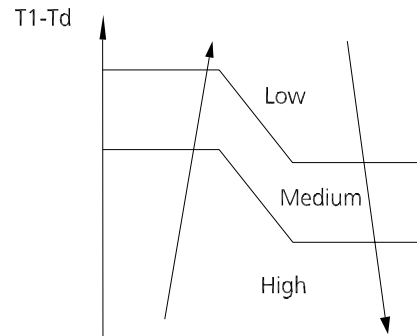

3.5.3 Outdoor Fan Control:

Case 1:

- The outdoor unit will be run at different fan speed according to T4 and compressor frequency.
- For different outdoor units, the fan speeds are different.

Case 2:

- The outdoor unit will be run at different fan speed according to T4.
- For different outdoor units, the fan speeds are different.

3.5.4 Defrosting mode

Case 1:

- The unit enters defrosting mode according to the temperature value of T3 and T4 as well as the compressor running time.
- In defrosting mode, the compressor continues to run, the indoor and outdoor motor will cease operation, the defrost light of the indoor unit will turn on, and the “” symbol is displayed.
- If any one of the following conditions is satisfied, defrosting ends and the machine switches to normal heating mode:
 - T3 rises above TCDE1.
 - T3 maintained above TCDE2 for 80 seconds.
 - Unit runs for 15 minutes consecutively in defrosting mode.
- If T4 is lower than or equal to -22°C(-7.6°F) and compressor running time is more than TIMING_DEFROST_TIME, if any one of the following conditions is satisfied, defrosting ends and the machine switches to normal heating mode:
 - Unit runs for 10 minutes consecutively in defrosting mode.
 - T3 rises above 10°C(50°F).

Case 2:

- The unit enters defrosting mode according to the temperature value of T3 as well as the compressor running time.
- In defrosting mode, the compressor continues to run, the indoor and outdoor motor will cease operation, the defrost light of the indoor unit will turn on, and the “” symbol is displayed.
- If any one of the following conditions is satisfied, defrosting ends and the machine switches to normal heating mode:
 - T3 rises above TCDE1.
 - T3 maintained above TCDE2 for 80 seconds.
 - Unit runs for 10 minutes consecutively in defrosting mode.

3.5.5 Evaporator Temperature Protection

When the evaporator temperature exceeds a preset protection value, the compressor ceases operation.

3.6 Drying mode

- Indoor fan speed is fixed at breeze and can't be changed. The louver angle is the same as in cooling mode.
- All protections are active and the same as that in cooling mode.

3.7 Auto-Restart

- The indoor unit has an auto-restart module that allows the unit to restart automatically. The module automatically stores the current settings (not including the swing setting) and, in the case of a sudden power failure, will restore those setting automatically within 3 minutes after power returns.
- If the unit was in forced cooling mode, it will run in this mode for 30 minutes and turn to auto mode with temperature set to 24°C.
- If there is a power failure while the unit is running, the compressor starts 3 minutes after the unit restarts. If the unit was already off before the power failure, the compressor starts 1 minute after the unit restarts.

Troubleshooting

Contents

1.	Safety Caution	3
2.	General Troubleshooting	4
3.	Outdoor Unit Point Check Function	6
4.	Complain Record Form	8
5.	Information Inquiry	10
6.	Error Diagnosis and Troubleshooting Without Error Code.....	13
	6.1 Remote maintenance.....	13
	6.2 Field maintenance	14
7.	Quick Maintenance by Error Code.....	19
8.	Troubleshooting by Error Code.....	22
	8.1 E0/F4 (EEPROM parameter error diagnosis and solution)	22
	8.2 E1 (Indoor and outdoor unit communication error)	23
	8.3 E3/F5 (Fan speed is operating outside of the normal range diagnosis and solution)	26
	8.4 E4/E5/F1/F2/F3//F6/P7(Open circuit or short circuit of temperature sensor diagnosis and solution)	28
	8.5 EE (Water-level alarm malfunction malfunction diagnosis and solution)	29
	8.6 EC (Refrigerant Leakage Detection diagnosis and solution)	30

Troubleshooting

Contents

8.7	Ed (Outdoor unit malfunction diagnosis and solution).....	31
8.8	E8 (Communication error between master and slave unit (for twins system) diagnosis and solution).....	32
8.9	F0 (Overload current protection diagnosis and solution).....	33
8.10	FA (Communication error between indoor two chips diagnosis and solution)	34
8.11	P0 (IPM malfunction or IGBT over-strong current protection diagnosis and solution)/P4(Inverter compressor drive error diagnosis and solution).....	35
8.12	P1 (Over voltage or too low voltage protection diagnosis and solution).....	37
8.13	P2 (Top temperature protection of compressor diagnosis and solution).....	39
8.14	P6/J6(Low pressure protection)	40
8.15	J0(Evaporator high temperature protection)	41
8.16	J1 (Condenser high temperature protection)	42
8.17	J2 (High discharge temperature protection).....	43
8.18	J3 (PFC module protection).....	44
8.19	J4 (Communication error between outdoor main chip and compressor driven chip).....	45
8.20	J5 (High pressure protection)	46
8.21	J8 (AC power input voltage protection)	47
8.22	P5 (Indoor units mode conflict).....	48
9.	Check Procedures.....	49

1. Safety Caution

⚠ WARNING

Be sure to turn off all power supplies or disconnect all wires to avoid electric shock. While checking indoor/outdoor PCB, please equip oneself with antistatic gloves or wrist strap to avoid damage to the board.

⚠ WARNING

Electricity remains in capacitors even when the power supply is off. Ensure the capacitors are fully discharged before troubleshooting.

Test the voltage between P and N on back of the main PCB with multimeter. If the voltage is lower than 36V, the capacitors are fully discharged.

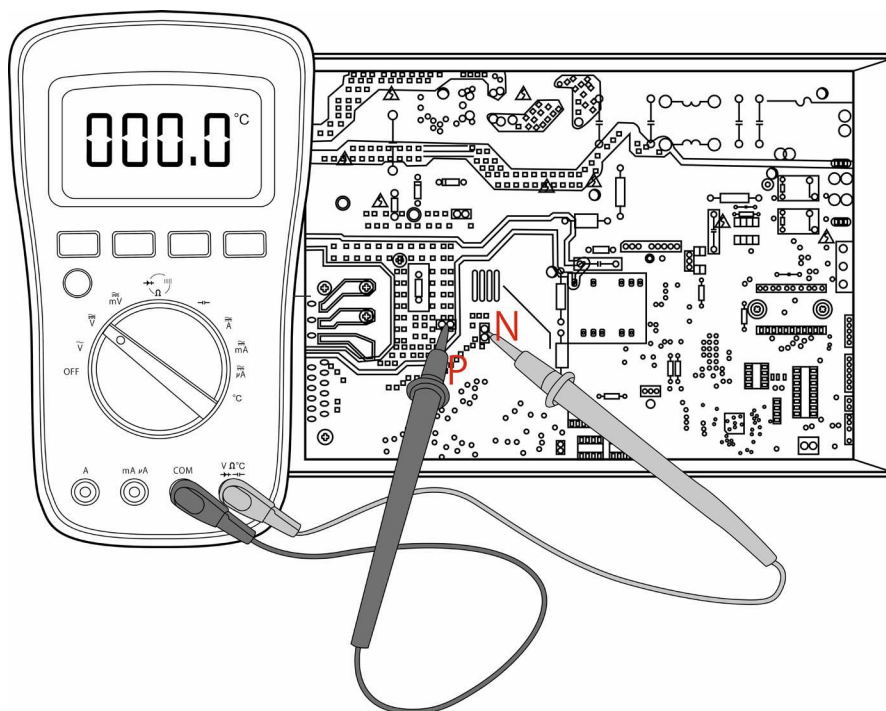

Note: This picture is for reference only. Actual appearance may vary.

2. General Troubleshooting

2.1 Error Display (Indoor Unit)

When the indoor unit encounters a recognized error, the operation lamp will flash in a corresponding series, the timer lamp may turn on or begin flashing, and an error code will be displayed. These error codes are described in the following table:

Operation Lamp	Timer Lamp	Display	Error Information	Solution
1 time	OFF	E0	Indoor unit EEPROM parameter error	TS22
2 times	OFF	E1	Indoor / outdoor unit communication error	TS23
4 times	OFF	E3	The indoor fan speed is operating outside of the normal range	TS26
5 times	OFF	E4	Indoor room temperature sensor T1 is in open circuit or has short circuited	TS28
6 times	OFF	E5	Evaporator coil temperature sensor T2 is in open circuit or has short circuited	TS28
7 times	OFF	E6	Refrigerant Leakage Detection(for some models)	TS30
8 times	OFF	E7	Water-level alarm malfunction	TS29
9 times	OFF	E8	Communication error between master and slave unit (for twins system)	TS32
10 times	OFF	E9	Another indoor unit malfunction (for twins system)	--
11 times	OFF	Ed	Outdoor unit malfunction	TS31
1 times	ON	F0	Current overload protection	TS33
2 times	ON	F1	Outdoor room temperature sensor T4 is in open circuit or has short circuited	TS28
3 times	ON	F2	Condenser coil temperature sensor T3 is in open circuit or has short circuited	TS28
4 times	ON	F3	Compressor discharge temperature sensor TP is in open circuit or has short circuited	TS28
5 times	ON	F4	Outdoor unit EEPROM parameter error	TS22
6 times	ON	F5	The outdoor fan speed is operating outside of the normal range(for some models)	TS26
7 times	ON	F6	Evaporator coil outlet temperature sensor T2B is in open circuit or has short circuited(for free-match indoor units)	TS28
11 times	ON	FR	Communication error between indoor two chips (for some models)	TS34
1 times	FLASH	P0	IPM malfunction or IGBT over-strong current protection	TS35
2 times	FLASH	P1	Over voltage or over low voltage protection	TS37
3 times	FLASH	P2	Top temperature protection of compressor	TS39
5 times	FLASH	P4	Inverter compressor drive error	TS35
6 times	FLASH	P5/--	Indoor units mode conflict(match with multi outdoor unit)	TS48
7 times	FLASH	P6	Low pressure protection (for some models)	TS40
8 times	FLASH	P7	IGBT temperature sensor TH is in open circuit or has short circuited (for some models)	TS28

For other errors:

The display board may show a garbled code or a code undefined by the service manual. Ensure that this code is not a temperature reading.

Troubleshooting:

Test the unit using the remote control. If the unit does not respond to the remote, the indoor PCB requires replacement. If the unit responds, the display board requires replacement.

2.2 Error Display (For Some Outdoor Units)

Display	Malfunction or Protection	Solution
E1	Indoor / outdoor unit communication error	TS23
F0	Current overload protection (for some units)	TS33
F1	Outdoor ambient temperature sensor T4 is in open circuit or has short circuited	TS28
F2	Condenser coil temperature sensor T3 is in open circuit or has short circuited	TS28
F3	Compressor discharge temperature sensor TP is in open circuit or has short circuited	TS28
F4	Outdoor unit EEPROM parameter error (for some units)	TS22
F5	The outdoor fan speed is operating outside of the normal range	TS26
P0	IPM module malfunction	TS35
P1	Over voltage or over low voltage protection	TS37
P2	Top of compressor high temperature protection(for some models)	TS39
P4	Inverter compressor drive protection	TS35
P7	IGBT temperature sensor TH is in open circuit or has short circuited(for some models)	TS28
J0	Evaporator high temperature protection	TS41
J1	Condenser high temperature protection	TS42
J2	High discharge temperature protection	TS43
J3	PFC module protection	TS44
J4	Communication error between outdoor main chip and compressor driven chip	TS45
J5	High pressure protection	TS46
J6	Low pressure protection	TS40
J8	AC power input voltage protection	TS47

2.3 Error Display on Two Way Communication Wired Controller

Display	Error Information	Solution
F0	Communication error between wired controller and indoor unit	--
E1	Indoor / outdoor unit communication error	TS23
E2	Indoor room temperature sensor T1 is in open circuit or has short circuited	TS28
E3	Evaporator coil temperature sensor T2 is in open circuit or has short circuited	TS28
E4	Indoor coil outlet temperature sensor T2B is in open circuit or has short circuited	TS28
E5	Outdoor coil temperature sensor malfunction T3 or Outdoor ambient temperature sensor malfunction T4 or Compressor discharge temperature sensor TP is in open circuit or has short circuited	TS28
E7	Indoor EEPROM malfunction	TS22
E8	The indoor fan speed is operating outside of the normal range	TS26
ER	Current overload protection	TS33
EB	IPM malfunction or IGBT over-strong current protection	TS35
Ed	Outdoor unit malfunction	--
EE	Water-level alarm malfunction	TS29
EF	Refrigerant leakage detection	TS30
EF	Other malfunction	--

3. Outdoor Unit Point Check Function

- A check switch is included on the outdoor PCB.
- Push SW1 to check the unit's status while running. The digital display shows the following codes each time the SW1 is pushed.

Number of Presses	Display	Remark
00	Normal display	Displays running frequency, running state, or malfunction code
01	Indoor unit capacity demand code	Actual data*HP*10 If capacity demand code is higher than 99, the digital display tube will show single digit and tens digit. (For example, the digital display tube show "5.0",it means the capacity demand is 15. the digital display tube show "60",it means the capacity demand is 6.0)
02	Amendatory capacity demand code	
03	The frequency after the capacity requirement transfer	
04	The frequency after the frequency limit	
05	The frequency of sending to 341 chip	
06	Indoor unit evaporator temperature	If the temp. is lower than 0 degree, the digital display tube will show "0".If the temp. is higher than 70 degree, the digital display tube will show "70".
07	Condenser pipe temp.(T3)	If the temp. is lower than -9 degree, the digital display tube will show "-9".If the temp. is higher than 70 degree, the digital display tube will show "70". If the indoor unit is not connected, the digital display tube will show: "--"
08	Outdoor ambient temp.(T4)	
09	Compressor discharge temp. (T5)	The display value is between 13~129 degree. If the temp. is lower than 13 degree, the digital display tube will show "13". If the temp. is higher than 99 degree, the digital display tube will show single digit and tens digit. (For example, the digital display tube show "0.5",it means the compressor discharge temp. is 105 degree. the digital display tube show "1.6",it means the compressor discharge temp. is 116 degree)
10	AD value of current	The display value is a hex number.
11	AD value of voltage	For example, the digital display tube shows "Cd", it means AD value is 205.
12	Indoor unit running mode code	Standby:0, Fan only 1,Cooling:2, Heating:3, Forced cooling:4, Drying:6, Self clean:8, Forced defrosting:10
13	Outdoor unit running mode code	Standby:0, Fan only 1,Cooling:2, Heating:3, Forced cooling:4, Drying:6, Self clean:8, Forced defrosting:10
14	EXV open angle	Actual data/4. If the value is higher than 99, the digital display tube will show single digit and tens digit. For example, the digital display tube show "2.0",it means the EXV open angle is 120×4=480p.)

15	Frequency limit symbol	Bit7	Frequency limit caused by IGBT radiator	The display value is a hexadecimal number. For example, the digital display show 2A, then Bit5=1, Bit3=1, and Bit1=1. This means that a frequency limit may be caused by T4, T3, or the current.
		Bit6	Frequency limit caused by PFC	
		Bit5	Frequency limit caused by T4.	
		Bit4	Frequency limit caused by T2.	
		Bit3	Frequency limit caused by T3.	
		Bit2	Frequency limit caused by T5.	
		Bit1	Frequency limit caused by current	
		Bit0	Frequency limit caused by voltage	
16	Outdoor unit fan motor state	Off: 0, Turbo:1 High speed:2, Med speed: 3, Low speed: 4, Breeze:5, Super breeze: 6 other speed:7		
17	IGBT radiator temp.	The display value is between 30~120 degree. If the temp. is lower than 30 degree, the digital display tube will show "30". If the temp. is higher than 99 degree, the digital display tube will show single digit and tens digit. (For example, the digital display tube show "0.5",it means the IGBT radiator temp. is 105 degree. the digital display tube show "1.6",it means the IGBT radiator temp. is 116 degree)		
18	Indoor unit number	The indoor unit can communicate with outdoor unit well. General:1, Twins:2		
19	Evaporator pipe temp. T2 of 1# indoor unit	If the temp. is lower than 0 degree, the digital display tube will show "0".If the temp. is higher than 70 degree, the digital display tube will show "70". If the indoor unit is not connected, the digital display tube will show: "--"		
20	Evaporator pipe temp. T2 of 2# indoor unit			
21	Evaporator pipe temp. T2 of 3# indoor unit			
22	1# Indoor unit capacity demand code	Actual data*HP*10		
23	2# Indoor unit capacity demand code	If capacity demand code is higher than 99, the digital display tube will show single digit and tens digit. (For example, the digital display tube show "5.0",it means the capacity demand is 15. the digital display tube show "60",it means the capacity demand is 6.0). If the indoor unit is not connected, the digital display tube will show: "--"		
24	3# Indoor unit capacity demand code			
25	Room temp. T1 of 1# indoor unit	If the temp. is lower than 0 degree, the digital display tube will show "0".If the temp. is higher than 70 degree, the digital display tube will show "70". If the indoor unit is not connected, the digital display tube will show: "--"		
26	Room temp. T1 of 2# indoor unit			
27	Average room temp. T1			
28	Reason of stop			
29	Evaporator pipe temp. T2B of 1# indoor unit	If the temp. is lower than 0 degree, the digital display tube will show "0".If the temp. is higher than 70 degree, the digital display tube will show "70". If the indoor unit is not connected, the digital display tube will show: "--"		
30	Evaporator pipe temp. T2B of 2# indoor unit			

4. Complain Record Form

Complain Record Form

Request No.:

Date:

Installation Date:

Service Date:

Customer Information			
Name		Telephone No.	
Home Address			
Email			
Product Information			
Indoor Unit Model		Outdoor Unit Model	
Serial No. of indoor unit			
Serial No. of outdoor unit			
Working Mode	<input type="checkbox"/> Cooling <input type="checkbox"/> Heating <input type="checkbox"/> Fan only <input type="checkbox"/> Dry		
Setting temperature	_____°C / °F	Fan speed	<input type="checkbox"/> Turbo <input type="checkbox"/> High <input type="checkbox"/> Medium <input type="checkbox"/> Low <input type="checkbox"/> Auto
Temperature of air inlet	_____°C / °F	Temperature of air outlet	_____°C / °F
Installation / Condition Information			
Indoor temperature	_____°C / °F	Indoor humidity	_____ %RH
Outdoor temperature	_____°C / °F	Outdoor humidity	_____ %RH
Length of Connecting pipe		Pipe diameter	Gas pipe: Liquid pipe:
Length of Wiring		wire diameter	
System Running Pressure	_____MPa or _____Bar or _____PSI		
Room size (L*W*H)			
Photo of Installation of Indoor unit (Photo #1)		Photo of Installation of Outdoor unit (Photo #2)	
Failure Description			
Error Code of Indoor unit		Code of Outdoor PCB	
Unit does not start			
Remote control does not work			
Indoor display shows nothing			
No cooling or heating at all			
Less cooling or heating			
Unit starts but stops shortly			
High noise			
High vibration			
Parameter Checking information by Remote controller			
Displaying code	Displaying code meaning	Display value	Display value meaning
T1	Room temperature		
T2	Indoor coil temperature		

T3	Outdoor coil temperature		
T4	Ambient temperature		
Tb	Outlet temperature of indoor coil		
TP	Discharge temperature		
TH	Suction temperature		
FT	Targeted frequency		
Fr	Actual frequency		
IF	Indoor fan speed		
OF	Outdoor fan speed		
LA	EXV opening steps		
CT	Compressor continuous running time		
ST	Causes of compressor stop.		
A0, A1, b0, b1, b2, b3, b4, b5, b6	Reserved		
dL	Current		
Ac	AC voltage		
Uo	DC voltage		
Td	Targeted temperature		
nA	Network address		
CF	Constant volume motor protection		
Pr	The actual static pressure		
--	Reserve		

Approval from Manufacturer	
<input type="checkbox"/> Approved	
<input type="checkbox"/> More Proof needed	
<input type="checkbox"/> Rejected	

5. Information Inquiry

- To enter information inquiry status, complete the following procedure within ten seconds:
 - Press LED(or DO NOT DISTURB) 3 times.
 - Press SWING(or AIR DIRECTION) 3 times.
- Finish 1 and 2 within 10 seconds, you will hear beeps for two seconds, which means the unit goes into parameter checking mode.
- Use the LED(or DO NOT DISTURB) and SWING(or AIR DIRECTION) buttons to cycle through information displayed.
- Pressing LED(or DO NOT DISTURB) will display the next code in the sequence. Pressing SWING(or AIR DIRECTION) will show the previous.
- The following table shows information codes. The screen will display this code for two seconds, then the information for 25 seconds.

Displayed code	Explanation	Displayed value	Meaning	Additional Notes
T1	Room temperature	-1F,-1E,-1d,-1c,-1b,-1A -19—99 A0,A1,...A9 b0,b1,...b9 c0,c1,...c9 d0,d1,...d9 E0,E1,...E9 F0,F1,...F9	-25,-24,-23,-22,-21,-20 -19—99 100,101,...109 110,111,...119 120,121,...129 130,131,...139 140,141,...149 150,151,...159	<ol style="list-style-type: none"> All displayed temperatures use actual values. All temperatures are displayed in °C regardless of remote used. T1, T2, T3, T4, and T2B display ranges from -25 to 70 °C. TP display ranges from -20 to 130 °C. The frequency display ranges from 0 to 159HZ. If the actual values exceed or fall short of the defined range, the values closest to the maximum and minimum values will be displayed.
T2	Indoor coil temperature			
T3	Outdoor coil temperature			
T4	Ambient temperature			
TB	Outlet temperature of indoor coil			
TP	Discharge temperature			
TH	Suction temperature			
FT	Targeted frequency			
FR	Actual frequency			
IF	Indoor fan speed	0 1,2,3,4	OFF Low speed, Medium speed, High speed, Turbo.	N/A Used for some large capacity motors.
OF	Outdoor fan speed	14-FF	Actual fan speed is equal to the display value converted to decimal value and multiplied by 10. This is measured in RPM.	Used for some small capacity motors. The display value is 14-FF (hexadecimal). The corresponding fan speed ranges from 200 to 2550RPM.
LR	EXV opening angle	0-FF	Actual EXV opening value is equal to the display value converted to decimal value and then multiplied by 2.	-
CT	Compressor continuous running time	0-FF	0-255 minutes	If the actual value exceeds or falls short of the defined range, the value closest to the maximum and minimum will be displayed.
ST	Causes of compressor stop	0-99	For a detailed explanation, contact technical support.	-

RO	Reserved	0-FF	-	-
RI				
b0				
b1				
b2				
b3				
b4				
b5				
b6				
dL				
Rc				
Uo				
Td				
RR				
CF				
PR				

6. Error Diagnosis and Troubleshooting Without Error Code

WARNING

Be sure to turn off unit before any maintenance to prevent damage or injury.

6.1 Remote maintenance

SUGGESTION: When troubles occur, please check the following points with customers before field maintenance.

No.	Problem	Solution
1	Unit will not start	TS15 - TS16
2	The power switch is on but fans will not start	TS15 - TS16
3	The temperature on the display board cannot be set	TS15 - TS16
4	Unit is on but the wind is not cold(hot)	TS15 - TS16
5	Unit runs, but shortly stops	TS15 - TS16
6	The unit starts up and stops frequently	TS15 - TS16
7	Unit runs continuously but insufficient cooling(heating)	TS15 - TS16
8	Cool can not change to heat	TS15 - TS16
9	Unit is noisy	TS15 - TS16

6.2 Field maintenance

	Problem	Solution
1	Unit will not start	TS17 - TS18
2	Compressor will not start but fans run	TS17 - TS18
3	Compressor and condenser (outdoor) fan will not start	TS17 - TS18
4	Evaporator (indoor) fan will not start	TS17 - TS18
5	Condenser (Outdoor) fan will not start	TS17 - TS18
6	Unit runs, but shortly stops	TS17 - TS18
7	Compressor short-cycles due to overload	TS17 - TS18
8	High discharge pressure	TS17 - TS18
9	Low discharge pressure	TS17 - TS18
10	High suction pressure	TS17 - TS18
11	Low suction pressure	TS17 - TS18
12	Unit runs continuously but insufficient cooling	TS17 - TS18
13	Too cool	TS17 - TS18
14	Compressor is noisy	TS17 - TS18
15	Horizontal louver can not revolve	TS17 - TS18

1.Remote Maintenance	Electrical Circuit	Refrigerant Circuit
Possible causes of trouble	Power failure	
	The main power tripped	
	Loose connections	
	Faulty transformer	
	The voltage is too high or too low	
	The remote control is powered off	
	Broken remote control	
	Dirty air filter	
	Dirty condenser fins	
	The setting temperature is higher/lower than the room's(cooling/heating)	
	The ambient temperature is too high/low when the mode is cooling/heating	
	Fan mode	
	SILENCE function is activated(optional function)	
	Frosting and defrosting frequently	
Test method / remedy	Test voltage	
	Close the power switch	
	Inspect connections - tighten	
	Change the transformer	
	Test voltage	
	Replace the battery of the remote control	
	Replace the remote control	
	Clean or replace	
	Clean	
	Adjust the setting temperature	
	Turn the AC later	
	Adjust to cool mode	
	Turn off SILENCE function.	
	Turn the AC later	
Unit will not start	☆	
The power switch is on but fans will not start	☆	
The temperature on the display board cannot be set		
Unit is on but the wind is not cold(hot)		
Unit runs, but shortly stops		
The unit starts up and stops frequently	☆	☆
Unit runs continuously but insufficient cooling/heating)		☆
Cool can not change to heat		
Unit is noisy		

1.Remote Maintenance	Others					
Possible causes of trouble	Heavy load condition	Loosen hold down bolts and / or screws	Bad airproof	The air inlet or outlet of either unit is blocked	Interference from cell phone towers and remote boosters	Shipping plates remain attached
Unit will not start						
The power switch is on but fans will not start					☆	
The temperature on the display board cannot be set						
Unit is on but the wind is not cold(hot)						
Unit runs, but shortly stops						
The unit starts up and stops frequently				☆		
Unit runs continuously but insufficient cooling(heating)	☆		☆	☆		
Cool can not change to heat						
Unit is noisy		☆				☆
Test method / remedy	Check heat load	Tighten bolts or screws	Close all the windows and doors	Remove the obstacles	Reconnect the power or press ON/OFF button on remote control to restart operation	Remove them

2. Field Maintenance	Electrical Circuit															
Possible causes of trouble	Unit will not start	Compressor will not start but fans run	Compressor and condenser (outdoor) fan will not start	Evaporator (indoor) fan will not start	Condenser (Outdoor) fan will not start	Unit runs, but shortly stops	Compressor short-cycles due to overload	High discharge pressure	Low discharge pressure	High suction pressure	Low suction pressure	Unit runs continuously but insufficient cooling	Too cool	Compressor is noisy	Horizontal louver can not revolve	
	Power failure	☆														
	Blown fuse or varistor	☆														
	Loose connections	☆													☆	
	Shorted or broken wires	☆	☆	☆	☆										☆	
	Safety device opens	☆														
	Faulty thermostat / room temperature sensor			☆	☆								☆			
	Wrong setting place of temperature sensor												☆			
	Faulty transformer															☆
	Shorted or open capacitor			☆	☆											
	Faulty magnetic contactor for compressor			☆	☆		☆	☆								
	Faulty magnetic contactor for fan				☆	☆										
	Low voltage						☆	☆								
	Faulty stepping motor														☆	
	Shorted or grounded compressor			☆												
	Shorted or grounded fan motor				☆	☆										
Test method / remedy	Test voltage	Inspect fuse type & size	Inspect connections - tighten	Test circuits with tester	Test continuity of safety device	Test continuity of thermostat / sensor & wiring	Place the temperature sensor at the central of the air inlet grille	Check control circuit with tester	Check capacitor with tester	Test continuity of coil & contacts	Test continuity of coil & contacts	Test voltage	Replace the stepping motor	Check resistance with multimeter	Check resistance with multimeter	

7. Quick Maintenance by Error Code

If you do not have the time to test which specific parts are faulty, you can directly change the required parts according the error code.

You can find the parts to replace by error code in the following table.

Part requiring replacement	Error Code									
	E0	E1	E3	E4	E5	EC	EE	F0	F1	F2
Indoor PCB	✓	✓	✓	✓	✓	✓	✓	x	x	x
Outdoor PCB	x	✓	x	x	x	x	x	✓	✓	✓
Indoor fan motor	x	x	✓	x	x	x	x	x	x	x
Outdoor fan motor	x	x	x	x	x	x	x	✓	x	x
T1 sensor	x	x	x	✓	x	x	x	x	x	x
T2 Sensor	x	x	x	x	✓	✓	x	x	x	x
T3 Sensor	x	x	x	x	x	x	x	x	x	✓
T4 Sensor	x	x	x	x	x	x	x	x	✓	x
TP Sensor	x	x	x	x	x	x	x	x	x	x
IGBT Sensor	x	x	x	x	x	x	x	x	x	x
Additional refrigerant	x	x	x	x	x	✓	x	✓	x	x
Capacitor of compressor	x	x	x	x	x	x	x	x	x	x
Compressor	x	x	x	x	x	x	x	✓	x	x
IPM board	x	x	x	x	x	x	x	x	x	x
Capacitor of fan motor	x	x	x	x	x	x	x	x	x	x
Outdoor fan	x	x	x	x	x	x	x	x	x	x
Display board	x	x	x	x	x	x	✓	x	x	x
Reactor or inductance	x	x	x	x	x	x	x	✓	x	x
Bridge rectifier	x	x	x	x	x	x	x	x	x	x
Water-level switch	x	x	x	x	x	x	✓	x	x	x
Water pump	x	x	x	x	x	x	✓	x	x	x

Part requiring replacement	Error Code								
	F2	F3	F4	F5	F6	P0/P4	P1	P6/L6	P7
Indoor PCB	x	x	x	x	x	x	x	x	x
Outdoor PCB	✓	✓	✓	✓	x	✓	✓	✓	✓
Indoor fan motor	x	x	x	x	x	x	x	x	x
Outdoor fan motor	x	x	x	✓	x	✓	x	x	x
T1 sensor	x	x	x	x	x	x	x	x	x
T2 Sensor	x	x	x	x	x	x	x	x	x
T3 Sensor	✓	x	x	x	x	x	x	x	x
T4 Sensor	x	x	x	x	x	x	x	x	x
TP Sensor	x	✓	x	x	x	✓	x	x	x
IGBT Sensor	x	x	x	x	x	x	x	x	✓
Additional refrigerant	x	x	x	x	x	x	x	x	x
Capacitor of compressor	x	x	x	x	x	x	x	x	x
Compressor	x	x	x	x	x	✓	✓	x	x
IPM board	x	x	x	x	x	✓	✓	x	x
Capacitor of fan motor	x	x	x	x	x	x	x	x	x
Outdoor fan	x	x	x	x	x	x	x	x	x
Display board	x	x	x	x	x	x	x	x	x
Reactor or inductance	x	x	x	x	x	✓	✓	x	x
Bridge rectifier	x	x	x	x	x	✓	✓	x	x
Pressure protector	x	x	x	x	x	x	x	✓	x
T2B Sensor	x	x	x	x	✓	x	x	x	x

Part requiring replacement	Error Code							
	U0	U1	U2	U3	U4	U5	U8	P2
Indoor PCB	x	x	x	x	x	x	x	x
Outdoor PCB	✓	✓	✓	✓	✓	✓	✓	✓
Indoor fan motor	x	x	x	x	x	x	x	x
Outdoor fan motor	✓	x	x	✓	x	x	x	x
T1 sensor	x	x	x	x	x	x	x	x
T2 Sensor	✓	x	x	x	x	x	x	x
T3 Sensor	x	✓	x	x	x	x	x	x
T4 Sensor	x	x	x	x	x	x	x	x
TP Sensor	x	x	✓	x	x	x	x	x
IGBT Sensor	x	x	x	x	x	x	x	x
Additional refrigerant	x	✓	✓	x	x	x	x	x
Capacitor of compressor	x	x	x	x	x	x	x	x
Compressor	x	✓	x	✓	x	x	x	x
IPM board	x	✓	x	✓	x	x	✓	x
Capacitor of fan motor	x	x	x	x	x	x	x	x
Outdoor fan	x	x	x	x	x	x	x	x
Display board	x	x	x	x	x	x	x	x
Reactor or inductance	x	x	x	x	x	x	✓	x
Bridge rectifier	x	x	x	x	x	x	✓	x
Pressure protector	x	x	x	x	x	✓	x	x
Compressor driven chip	x	x	x	x	✓	x	x	x
Overload protector	x	x	x	x	x	x	x	✓

Note: For certain models, outdoor PCB could not be removed separately. In this case, the outdoor electric control box should be replaced as a whole.

8. Troubleshooting by Error Code

8.1 E0 / F4 (EEPROM parameter error diagnosis and solution)

Description: Indoor or outdoor PCB main chip does not receive feedback from EEPROM chip.

Recommended parts to prepare:

- Indoor PCB
- Outdoor PCB

Troubleshooting and repair:

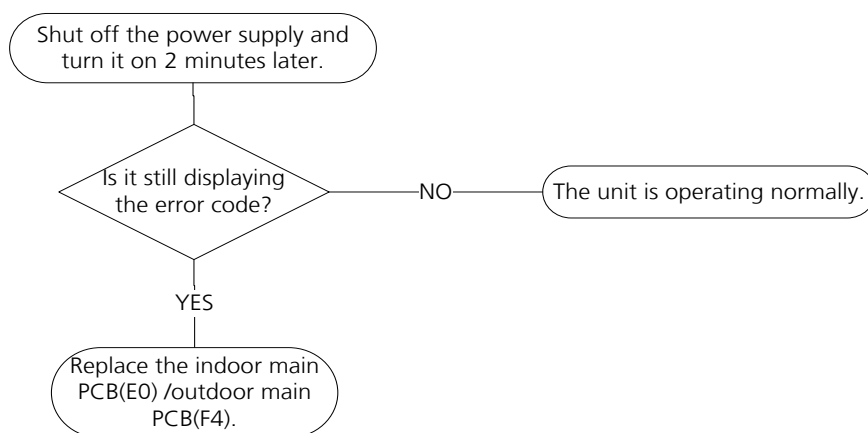

Remarks:

EEPROM: A read-only memory whose contents can be erased and reprogrammed using a pulsed voltage.

The location of the EEPROM chip on the indoor and outdoor PCB is shown in the following two images:

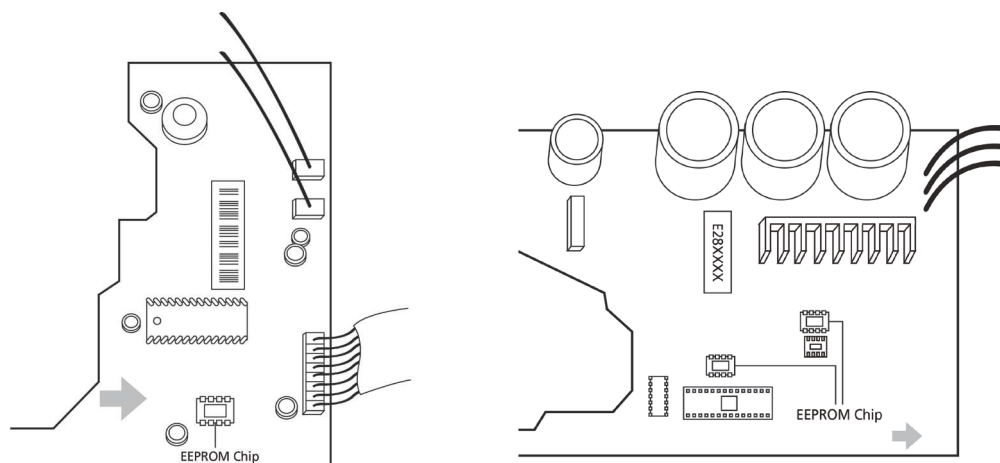

Note: For certain models, outdoor PCB could not be removed separately. In this case, the outdoor electric control box should be replaced as a whole. This pictures are only for reference, actual appearance may vary.

8.2 E1 (Indoor and outdoor unit communication error diagnosis and solution)

Description: Indoor unit can not communicate with outdoor unit

Recommended parts to prepare:

- Indoor PCB
- Outdoor PCB
- Reactor

Troubleshooting and repair:

For S communication:

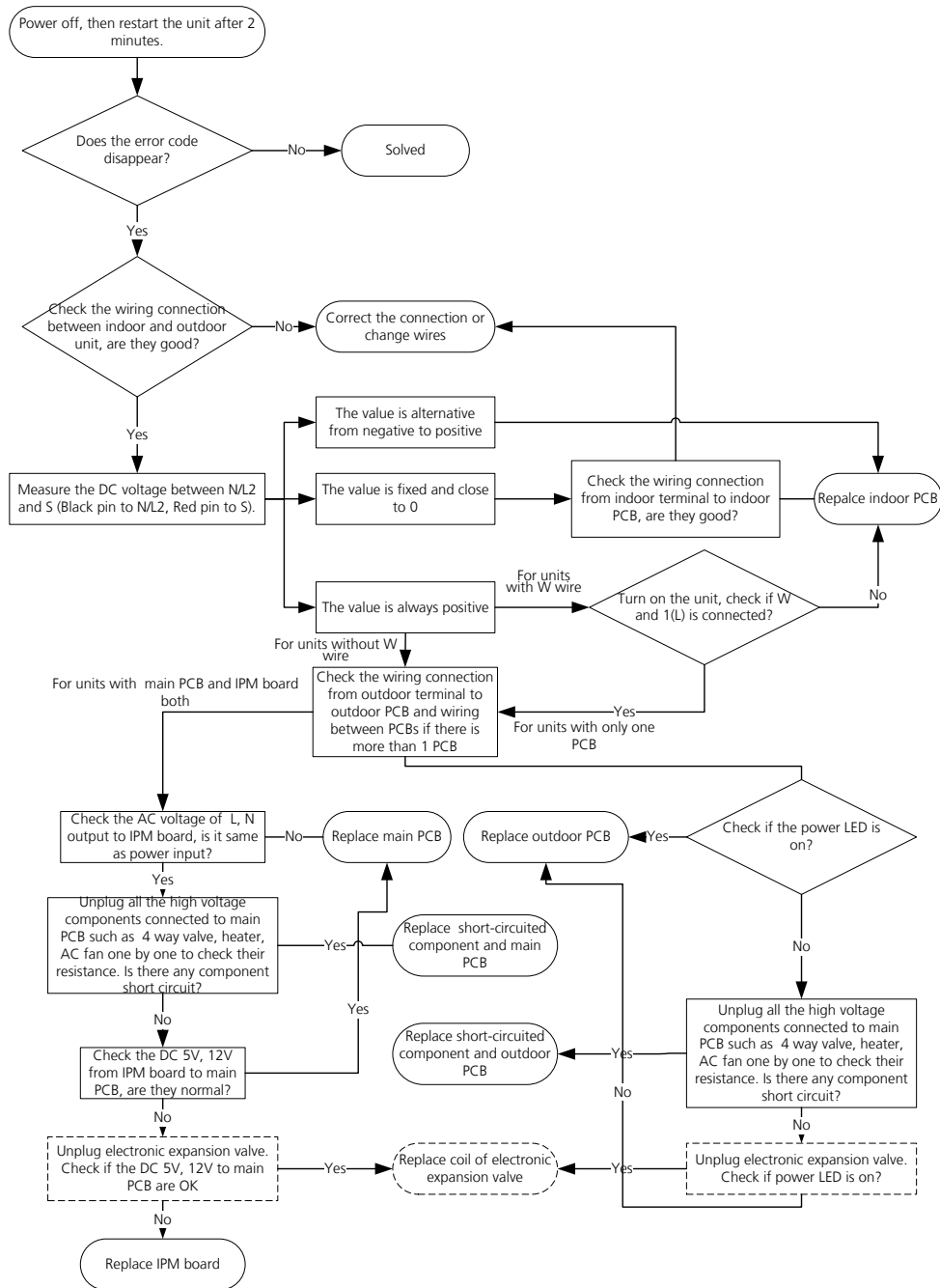

Note: For certain models, outdoor PCB could not be removed separately. In this case, the outdoor electric control box should be replaced as a whole.

Remarks:

- Use a multimeter to test the DC voltage between 2 port(or S or L2 port) and 3 port(or N or S port) of outdoor unit. The red pin of multimeter connects with 2 port(or S or L2 port) while the black pin is for 3 port(or N or S port) .
- When AC is normal running, the voltage is moving alternately as positive values and negative values
- If the outdoor unit has malfunction, the voltage has always been the positive value.
- While if the indoor unit has malfunction, the voltage has always been a certain value.

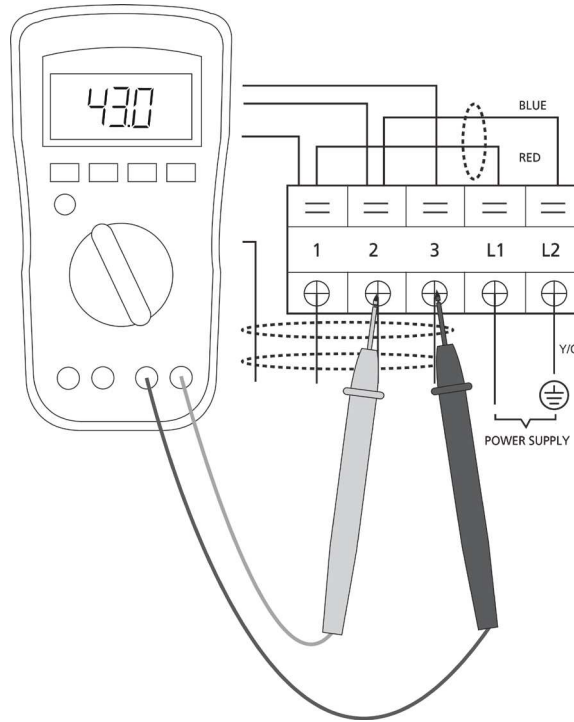

- Use a multimeter to test the resistance of the reactor which does not connect with capacitor.
- The normal value should be around zero ohm. Otherwise, the reactor must have malfunction.

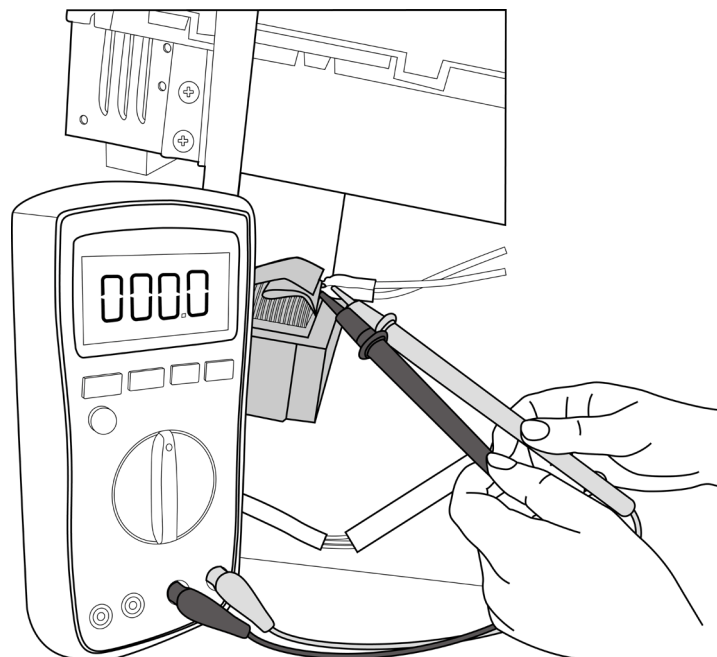

Note: The picture and the value are only for reference, actual condition and specific value may vary.

For XYE communication:

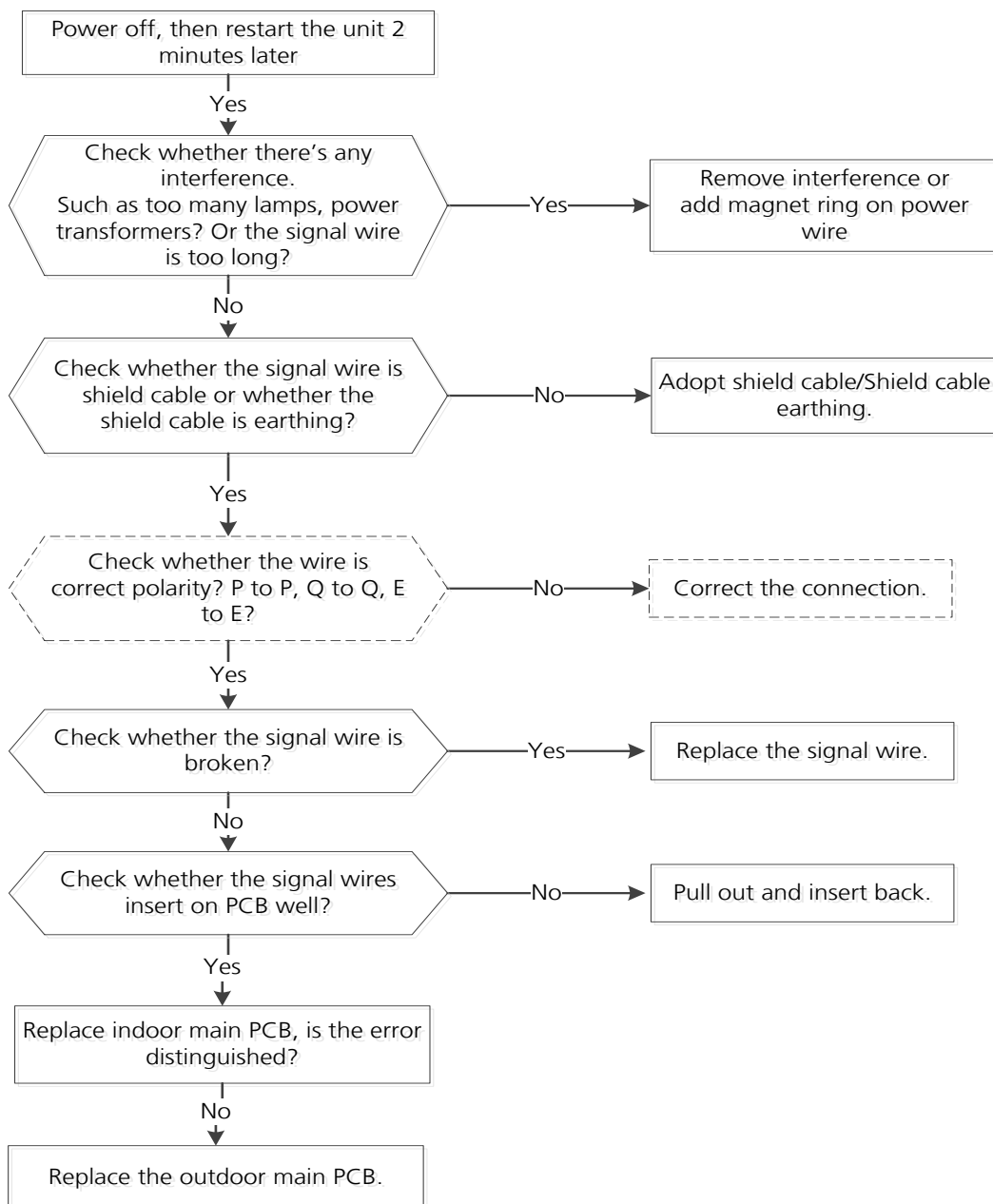

8.3 E3 / F5 (Fan speed is operating outside of normal range diagnosis and solution)

Description: When indoor / outdoor fan speed keeps too low or too high for a certain time, the unit will stop and the LED will display the failure.

Recommended parts to prepare:

- Connection wires
- Fan assembly
- Fan motor
- PCB

Troubleshooting and repair:

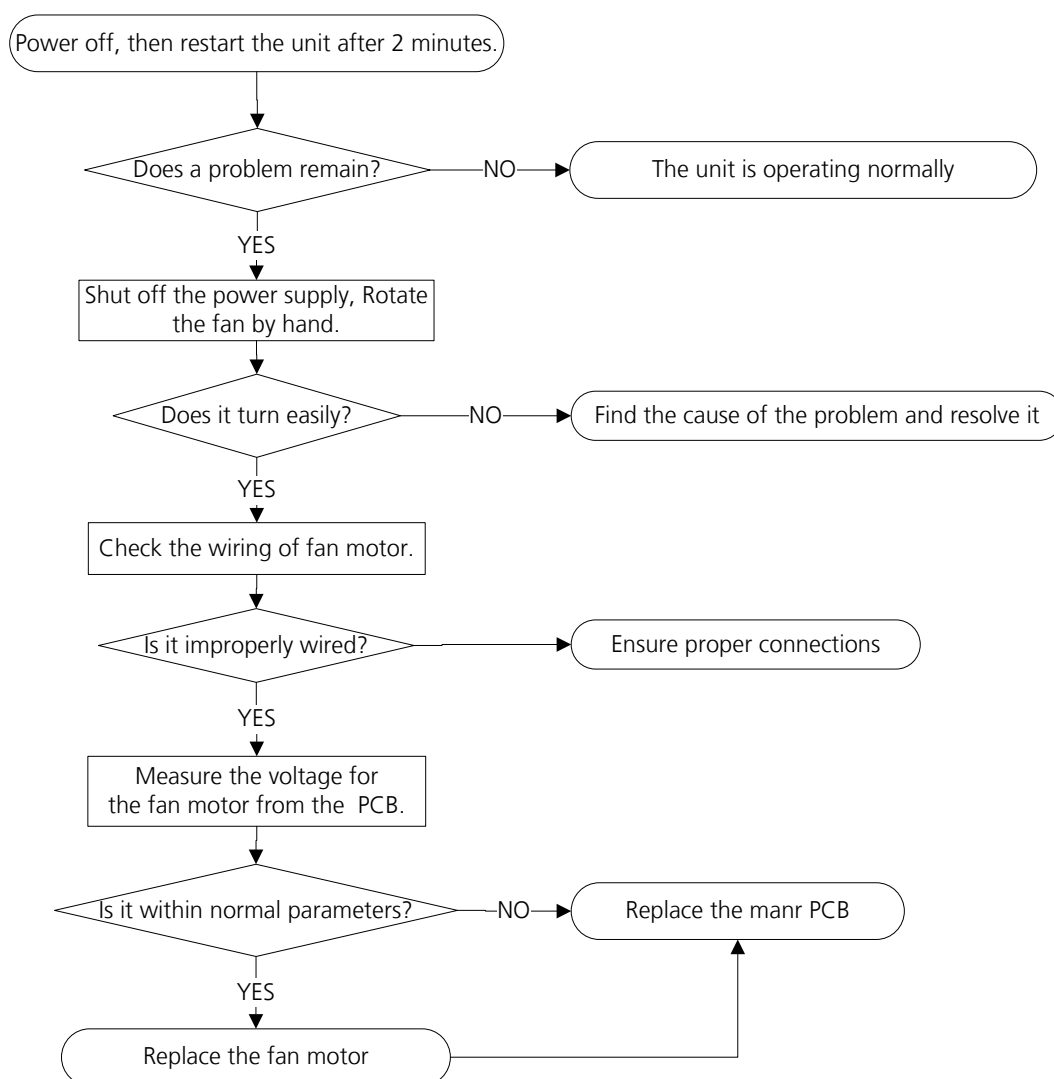

Note: For certain models, outdoor PCB could not be removed separately. In this case, the outdoor electric control box should be replaced as a whole.

Index:

1. Indoor or Outdoor DC Fan Motor(control chip is in fan motor)

Power on and when the unit is in standby, measure the voltage of pin1-pin3, pin4-pin3 in fan motor connector. If the value of the voltage is not in the range showing in below table, the PCB must has problems and need to be replaced.

- DC motor voltage input and output (voltage: 220-240V~):

No.	Color	Signal	Voltage
1	Red	Vs/Vm	280V~380V
2	---	---	---
3	Black	GND	0V
4	White	Vcc	14-17.5V
5	Yellow	Vsp	0~5.6V
6	Blue	FG	14-17.5V

- DC motor voltage input and output (voltage: 115V~):

No.	Color	Signal	Voltage
1	Red	Vs/Vm	140V~190V
2	---	---	---
3	Black	GND	0V
4	White	Vcc	14-17.5V
5	Yellow	Vsp	0~5.6V
6	Blue	FG	14-17.5V

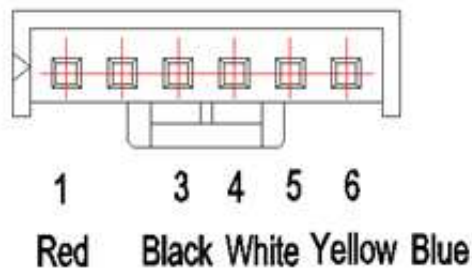

2. Outdoor DC Fan Motor (control chip is in outdoor PCB)

Release the UVW connector. Measure the resistance of U-V, U-W, V-W. If the resistance is not equal to each other, the fan motor must has problems and need to be replaced. otherwise the PCB must has problems and need to be replaced.

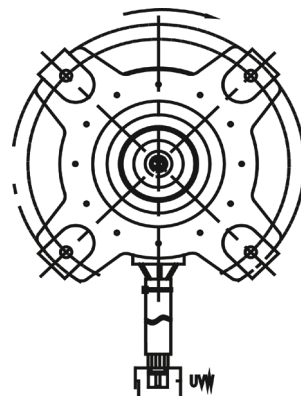

8.4 E4/E5/F1/F2/F3/F6/P7 (Open circuit or short circuit of temperature sensor diagnosis and solution)

Description: If the sampling voltage is lower than 0.06V or higher than 4.94V, the LED will display the failure.

Recommended parts to prepare:

- Connection wires
- Sensors
- PCB

Troubleshooting and repair:

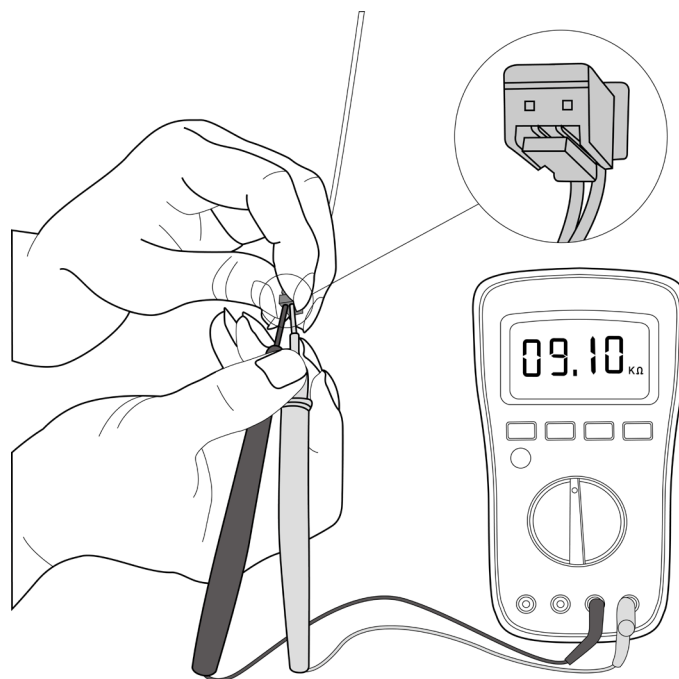
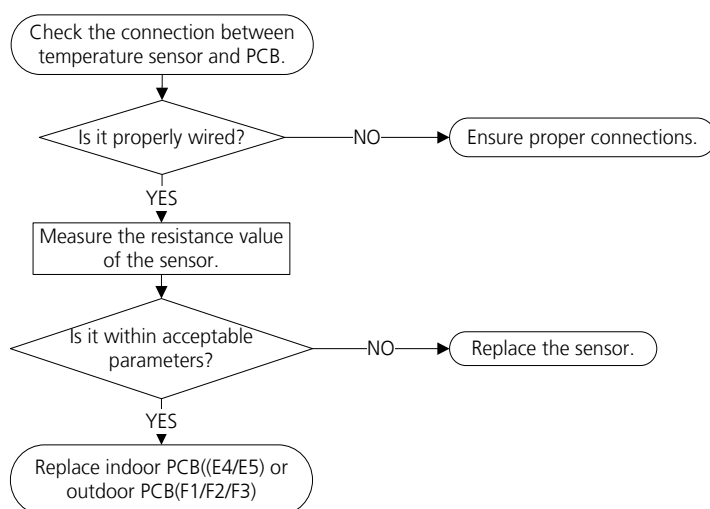

Note: For certain models, outdoor PCB could not be removed separately. In this case, the outdoor electric control box should be replaced as a whole. This picture and the value are only for reference, actual appearance and value may vary

8.5 EE (Water-Level Alarm Malfunction Diagnosis and Solution)

Description: If the sampling voltage is not 5V, the LED displays the failure code.

Recommended parts to prepare:

- Connection wires
- Water-level switch
- Water pump
- Indoor PCB

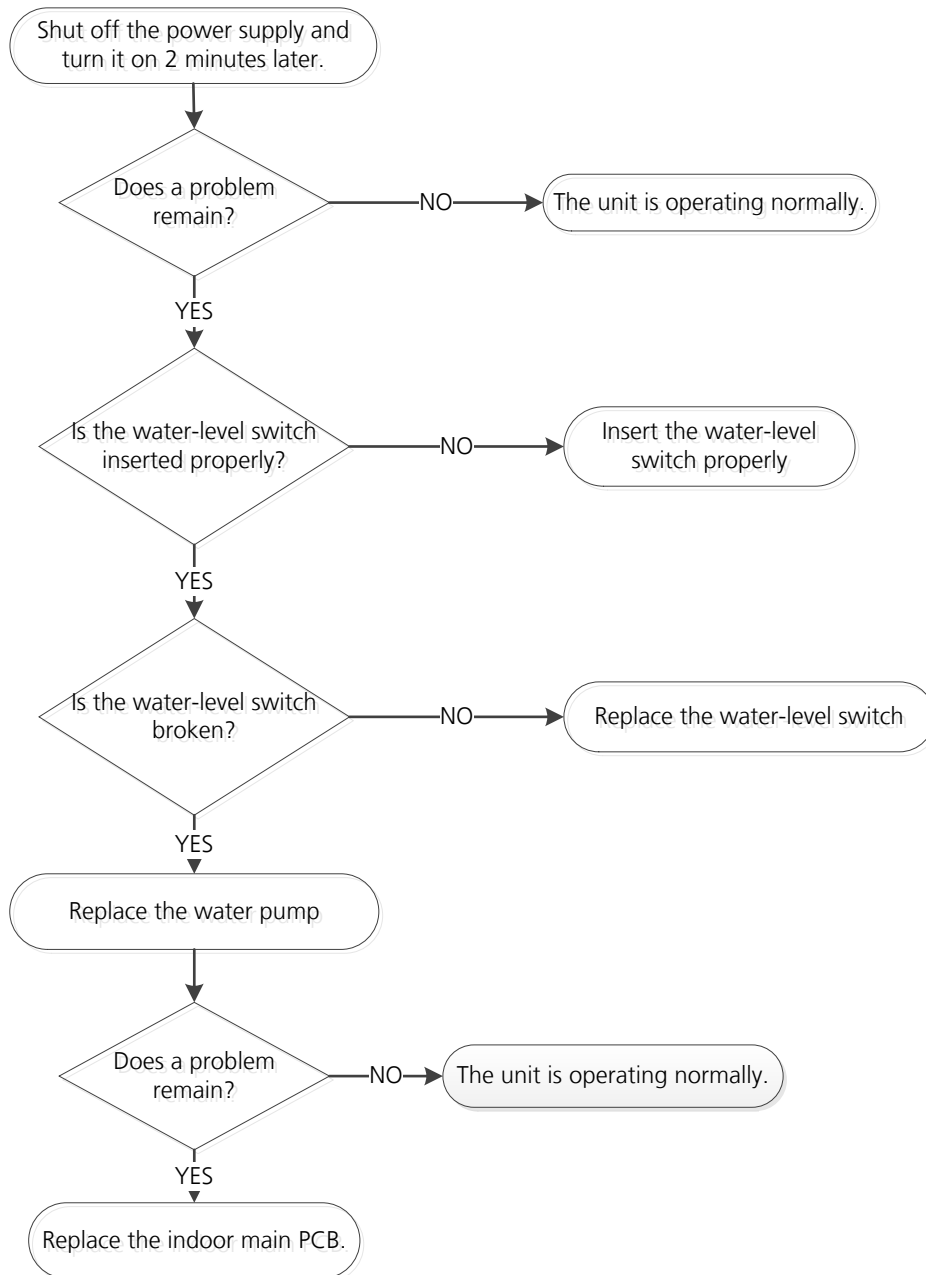

8.6 EC (Refrigerant Leakage Detection diagnosis and solution)

Description: Define the evaporator coil temperature T2 of the compressor just starts running as Tcool.

In the beginning 5 minutes after the compressor starts up, if $T2 < T_{cool} - 1^{\circ}\text{C}$ (1.8°F) does not keep continuous 4 seconds and compressor running frequency higher than 50Hz does not keep for 3 minutes, and this situation happens 3 times, the display area will show "EC" and AC will turn off.

Recommended parts to prepare:

- T2 sensor
- Indoor PCB
- Additional refrigerant

Troubleshooting and repair:

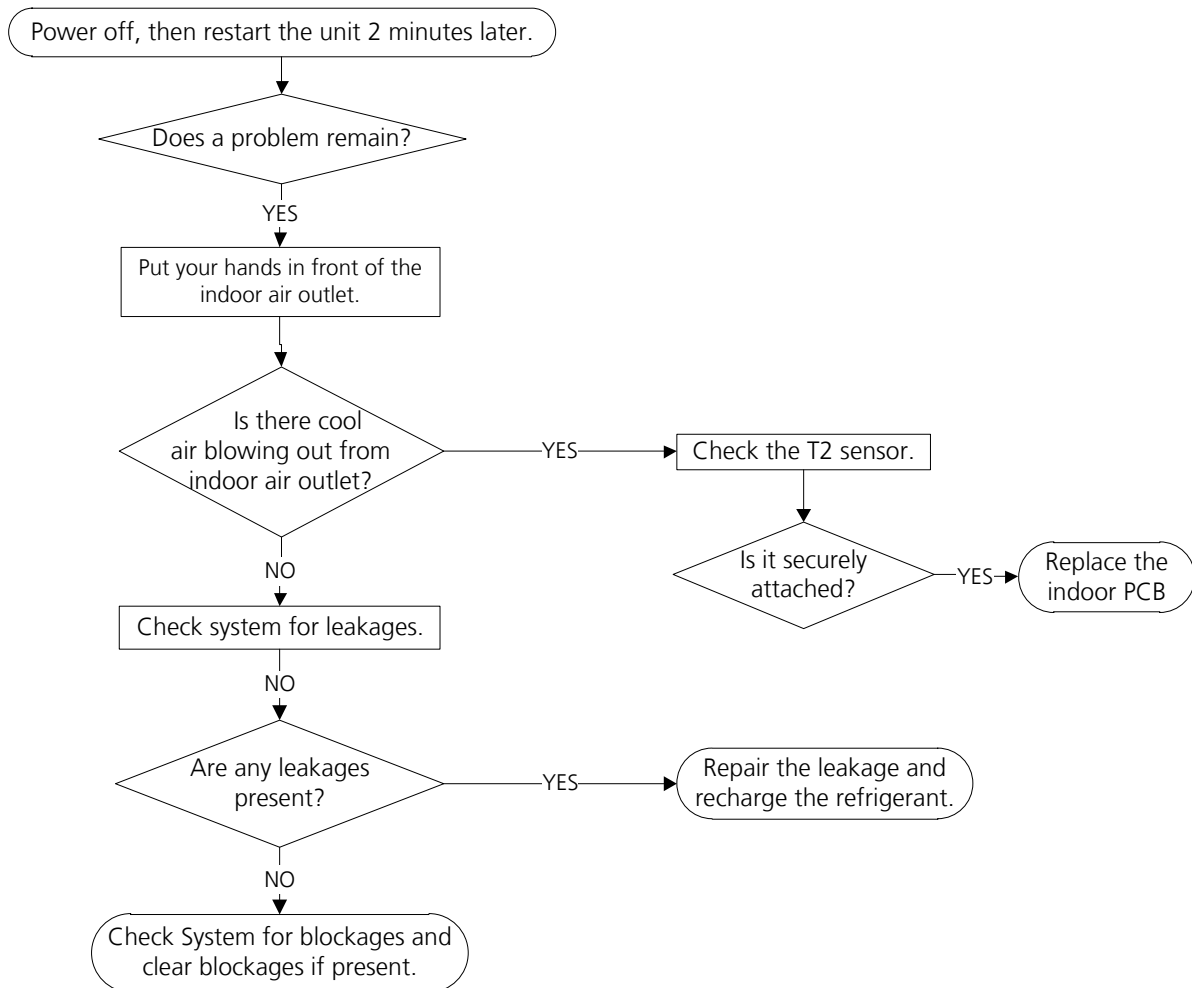

8.7 Ed (Outdoor unit malfunction Diagnosis and Solution)

Description: The indoor unit detect the outdoor unit is error.

Recommended parts to prepare:

- Outdoor unit

Troubleshooting and repair:

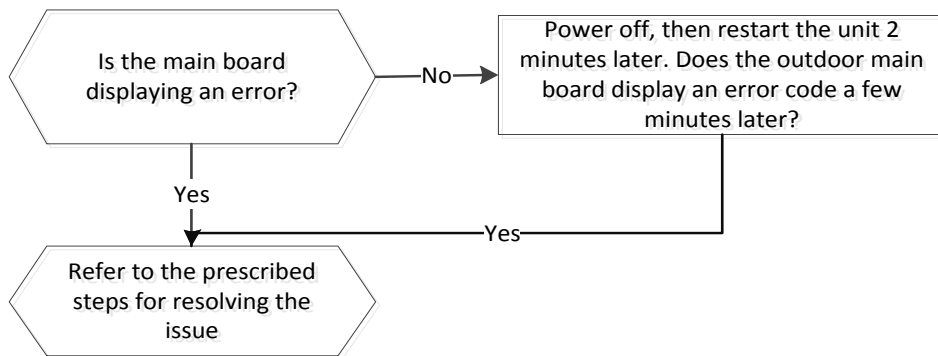

8.8 E8(Communication error between master and slave unit (for twins system) Diagnosis and Solution)

Description: When set in twins system, master unit and slave unit cannot be recognized normally.

Recommended parts to prepare:

- Connection wires
- Indoor PCB

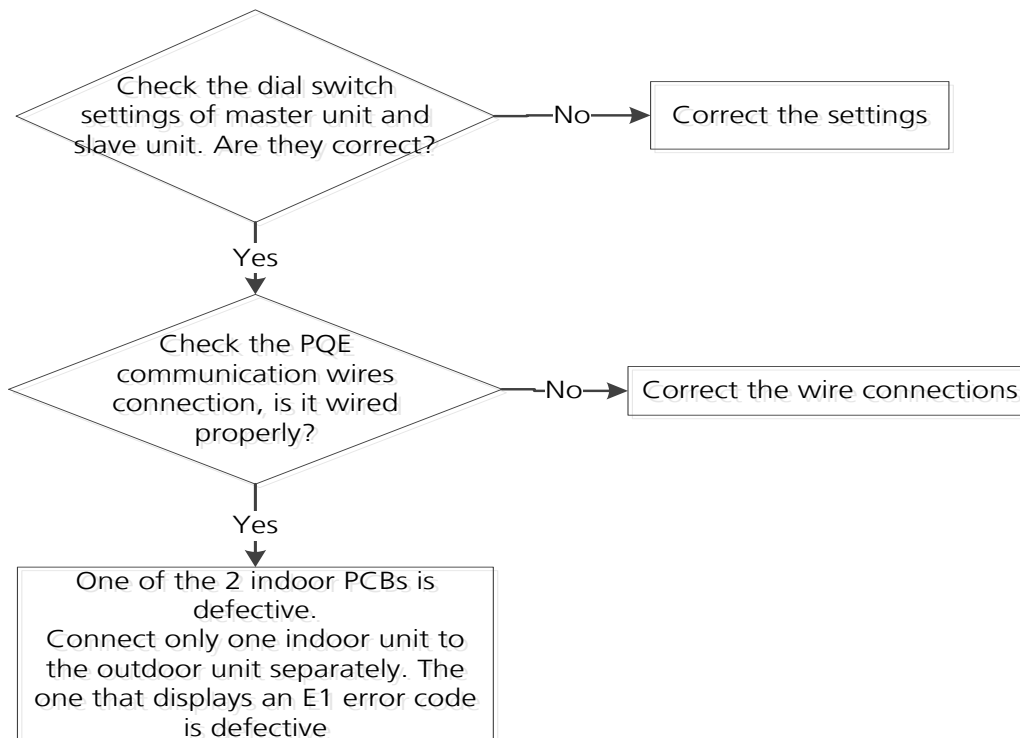

8.9 F0 (Overload current protection diagnosis and solution)

Description: An abnormal current rise is detected by checking the specified current detection circuit.

Recommended parts to prepare:

- Outdoor PCB
- Connection wires
- Compressor
- Reactor

Troubleshooting and repair:

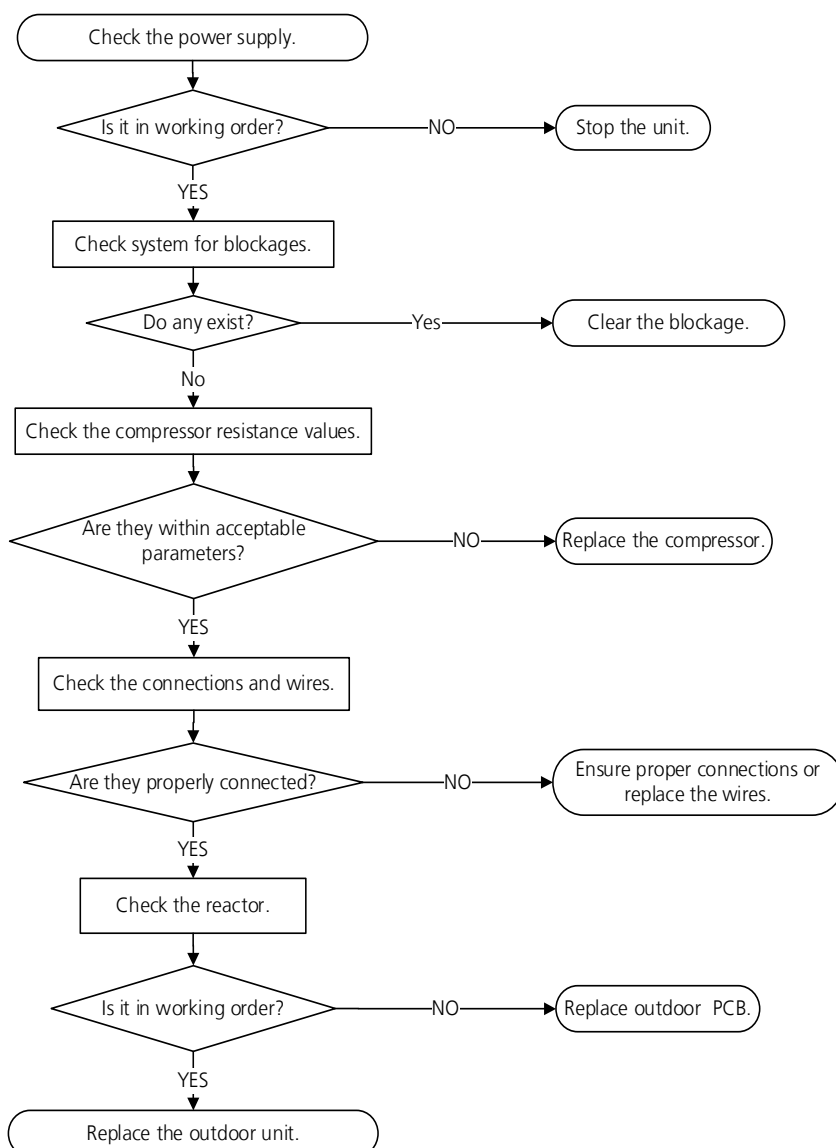

Note: For certain models, outdoor PCB could not be removed separately. In this case, the outdoor electric control box should be replaced as a whole.

8.10 FA (Communication error between indoor two chips diagnosis and solution)

Description: Indoor PCB main chip does not receive feedback from another chip.

Recommended parts to prepare:

- Indoor PCB

Troubleshooting and repair:

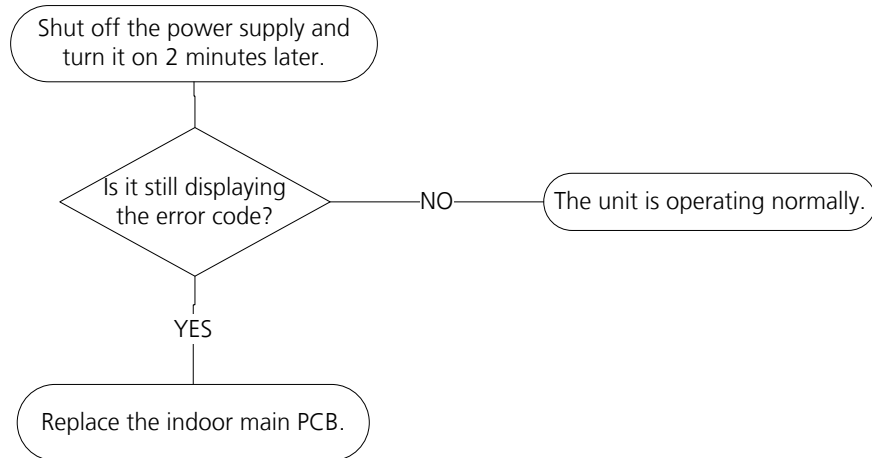

8.11 P0 (IPM malfunction diagnosis and solution)&P4(Inverter compressor drive error diagnosis and solution)

Description: P0:When the voltage signal the IPM sends to the compressor drive chip is abnormal, the LED displays the failure code and the AC turns off.

P4:The driven chip cannot detect the right rotor position of compressor

Recommended parts to prepare:

- Connection wires
- IPM module board
- Outdoor fan assembly
- Compressor
- Outdoor PCB

Troubleshooting and repair:

At first test the resistance between every two ports of U, V, W of IPM and P, N. If any result of them is 0 or close to 0, the IPM is defective. Otherwise, please follow the procedure below:

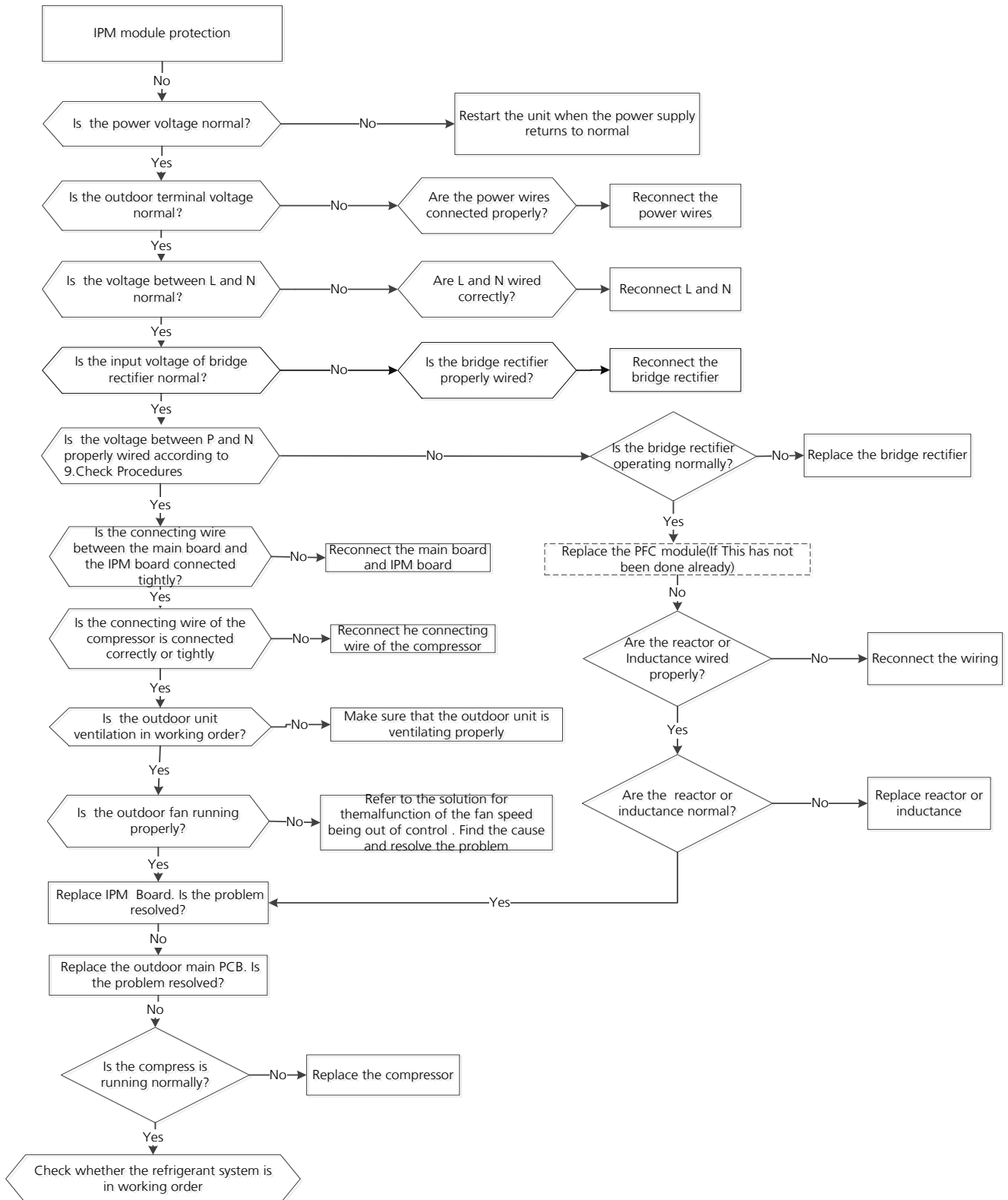

Note: For certain models, outdoor PCB could not be removed separately. In this case, the outdoor electric control box should be replaced as a whole.

8.12 P1(Over voltage or too low voltage protection diagnosis and solution)

Description: Abnormal increases or decreases in voltage are detected by checking the specified voltage detection circuit.

Recommended parts to prepare:

- Power supply wires
- IPM module board
- Outdoor PCB
- Bridge rectifier
- PFC circuit or reactor

Troubleshooting and repair:

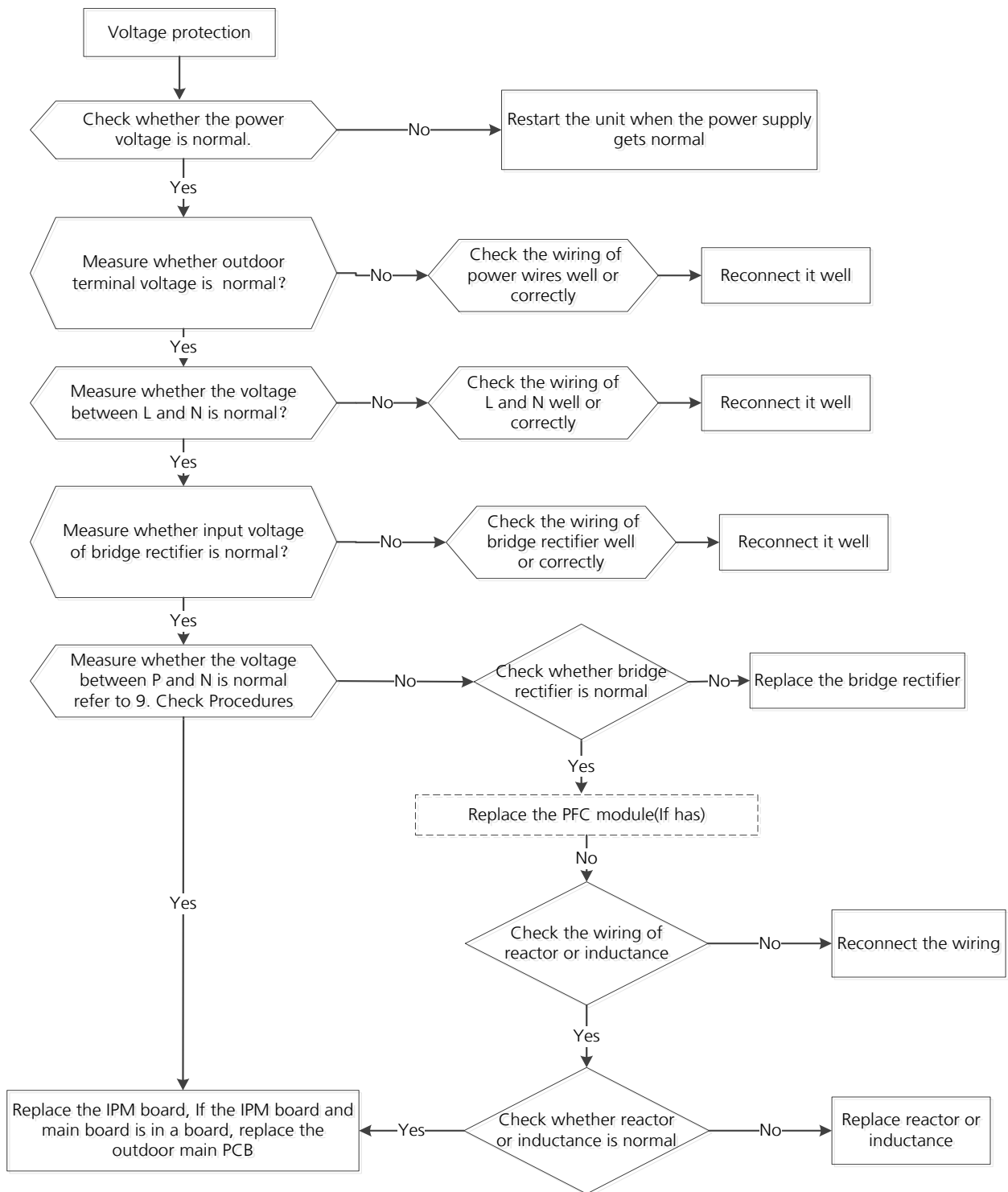

Note: For certain models, outdoor PCB could not be removed separately. In this case, the outdoor electric control box should be replaced as a whole.

8.13 P2(Top temperature protection of compressor diagnosis and solution)

Description: If the sampling voltage is not 5V, the LED will display the failure.

Recommended parts to prepare:

- Connection wires
- Overload protector
- Outdoor PCB

Troubleshooting and repair:

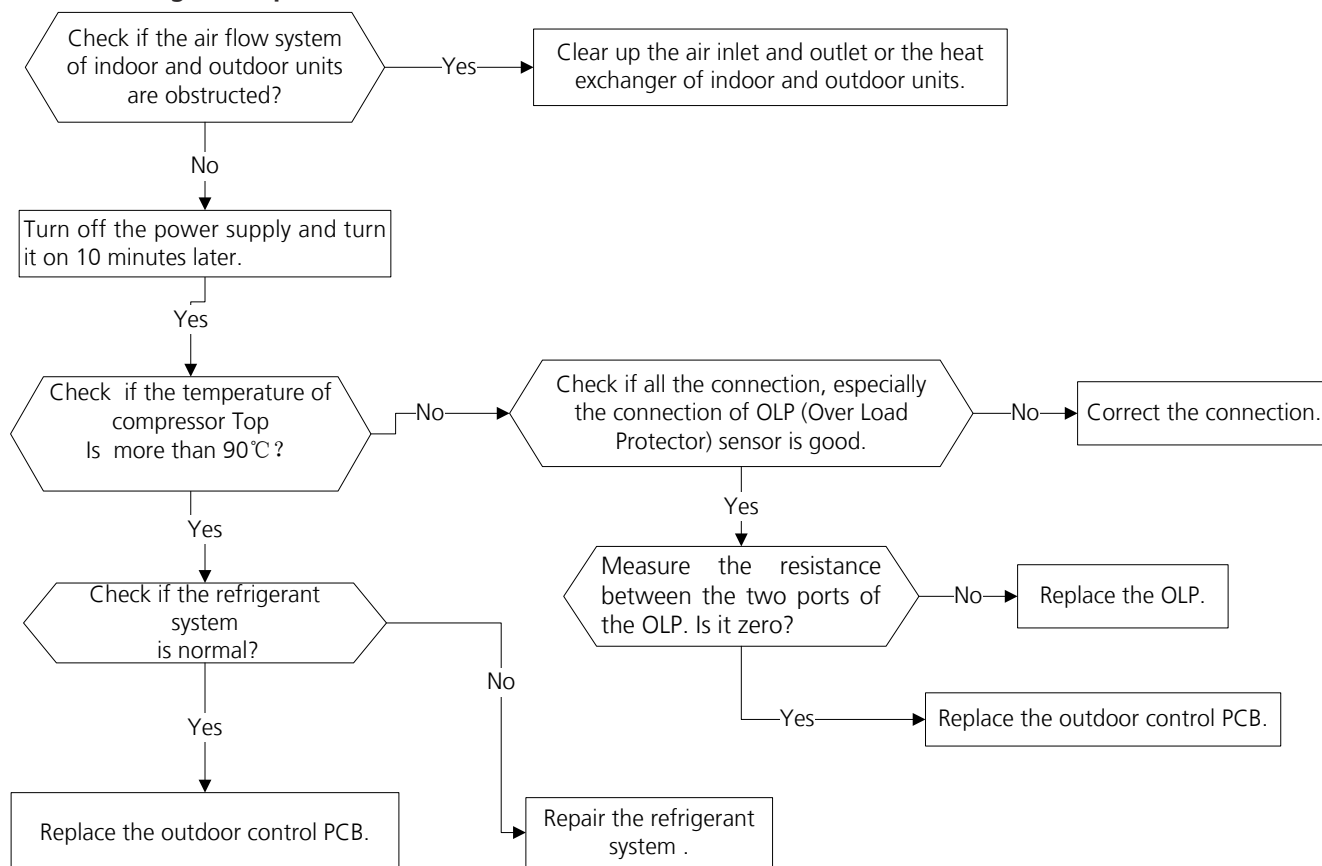

Note: For certain models, outdoor PCB could not be removed separately. In this case, the outdoor electric control box should be replaced as a whole.

8.14 P6/J6(Low pressure protection)

Description: If the sampling voltage is not 5V, the LED displays a failure code.

Recommended parts to prepare:

- Wiring mistake
- Over load protector
- System blockages
- Outdoor PCB

Troubleshooting and repair:

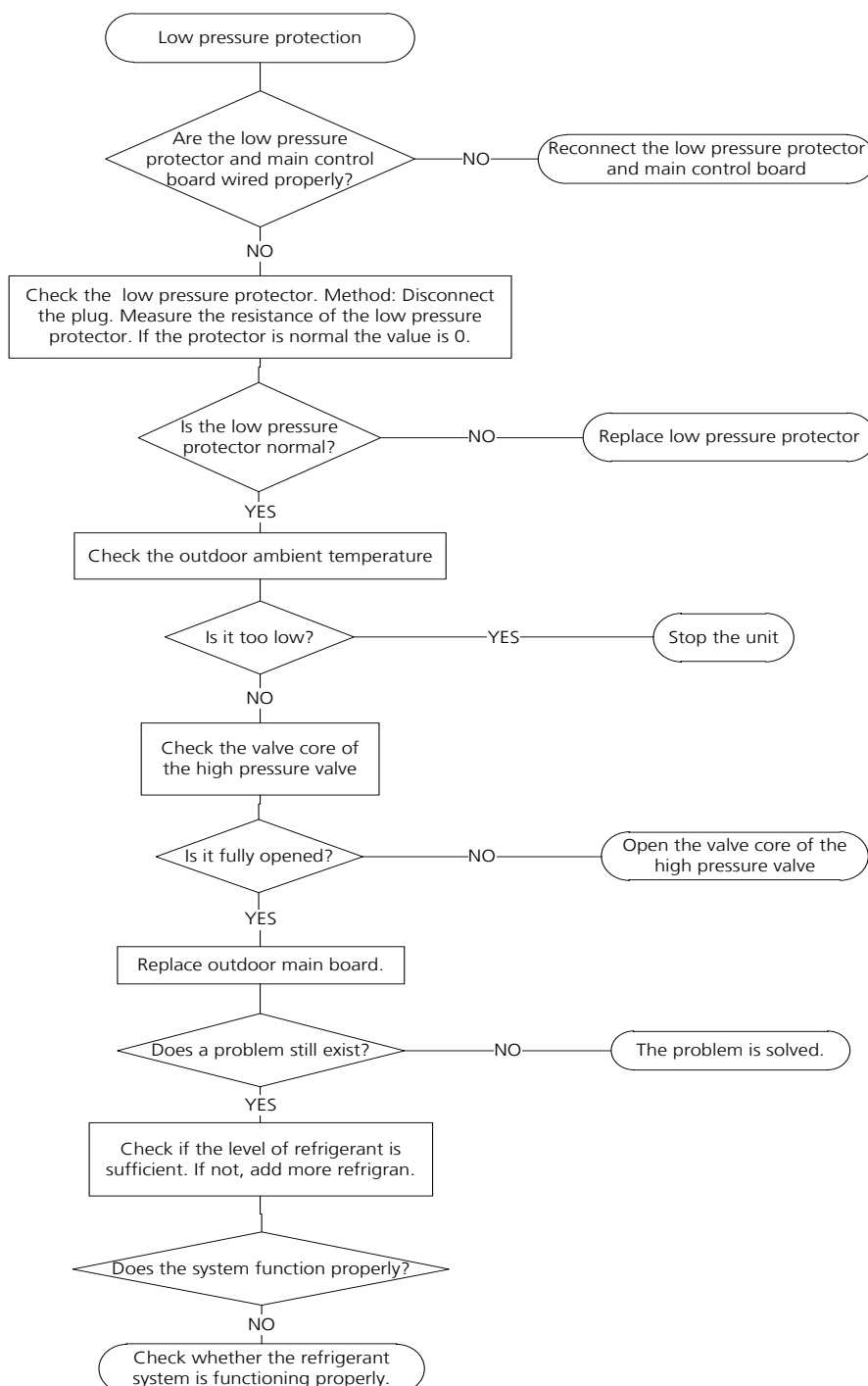

8.15 J0(Evaporator high temperature protection)

Description: When evaporator coil temperature is more than 60°C, the unit stops. It starts again only when the evaporator coil temperature is less than a certain value.

Recommended parts to prepare:

- Evaporator coil temperature sensor
- Fan
- PCB

Troubleshooting and repair:

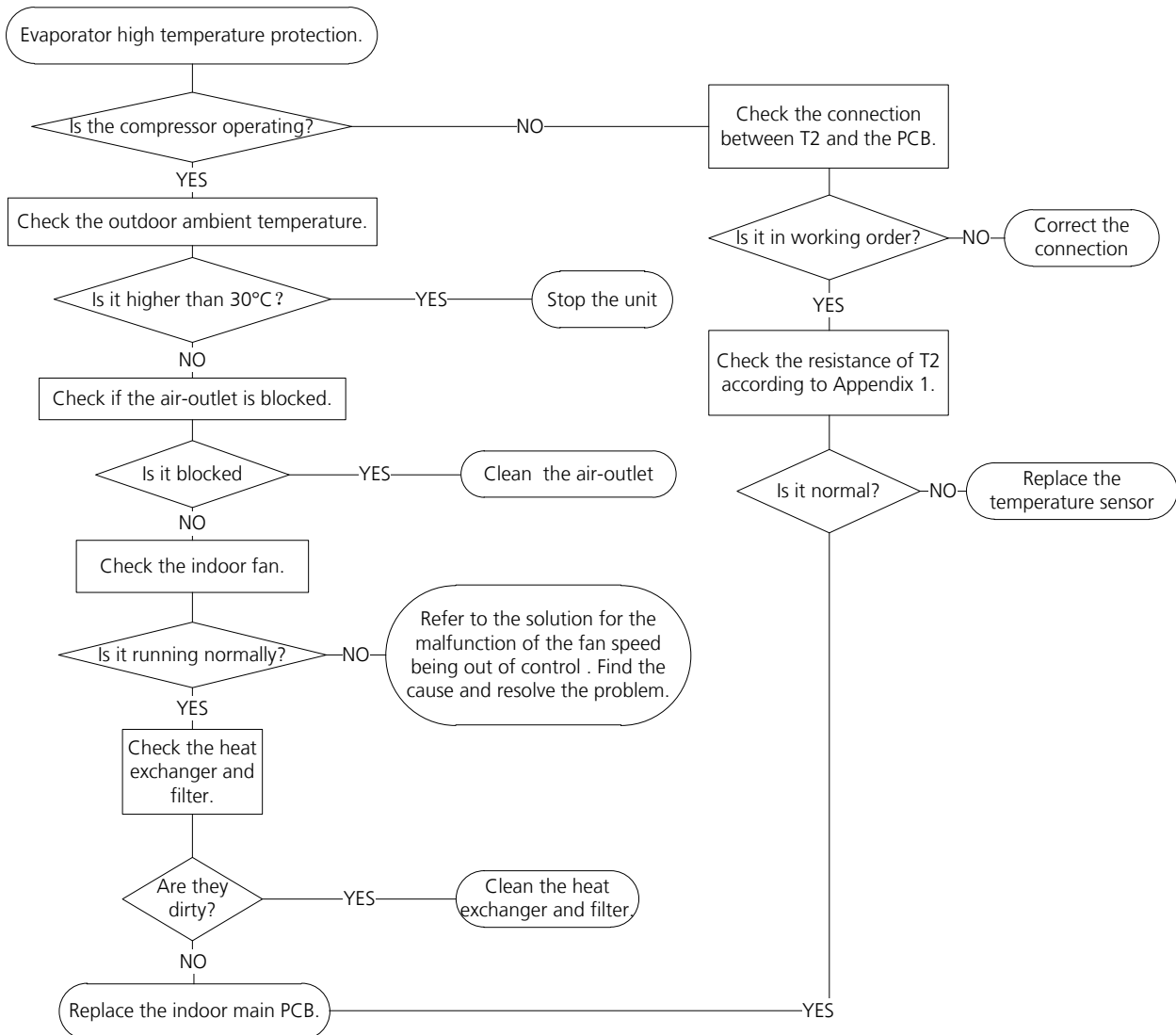

8.16 J1 (Condenser high temperature protection)

Description: When the outdoor pipe temperature is more than $TP3+5^{\circ}\text{C}$, the unit stops. It starts again only when the outdoor pipe temperature is less than $TP3-3^{\circ}\text{C}$.

Recommended parts to prepare:

- Condenser temperature sensor
- System leakage or blockages

Troubleshooting and repair:

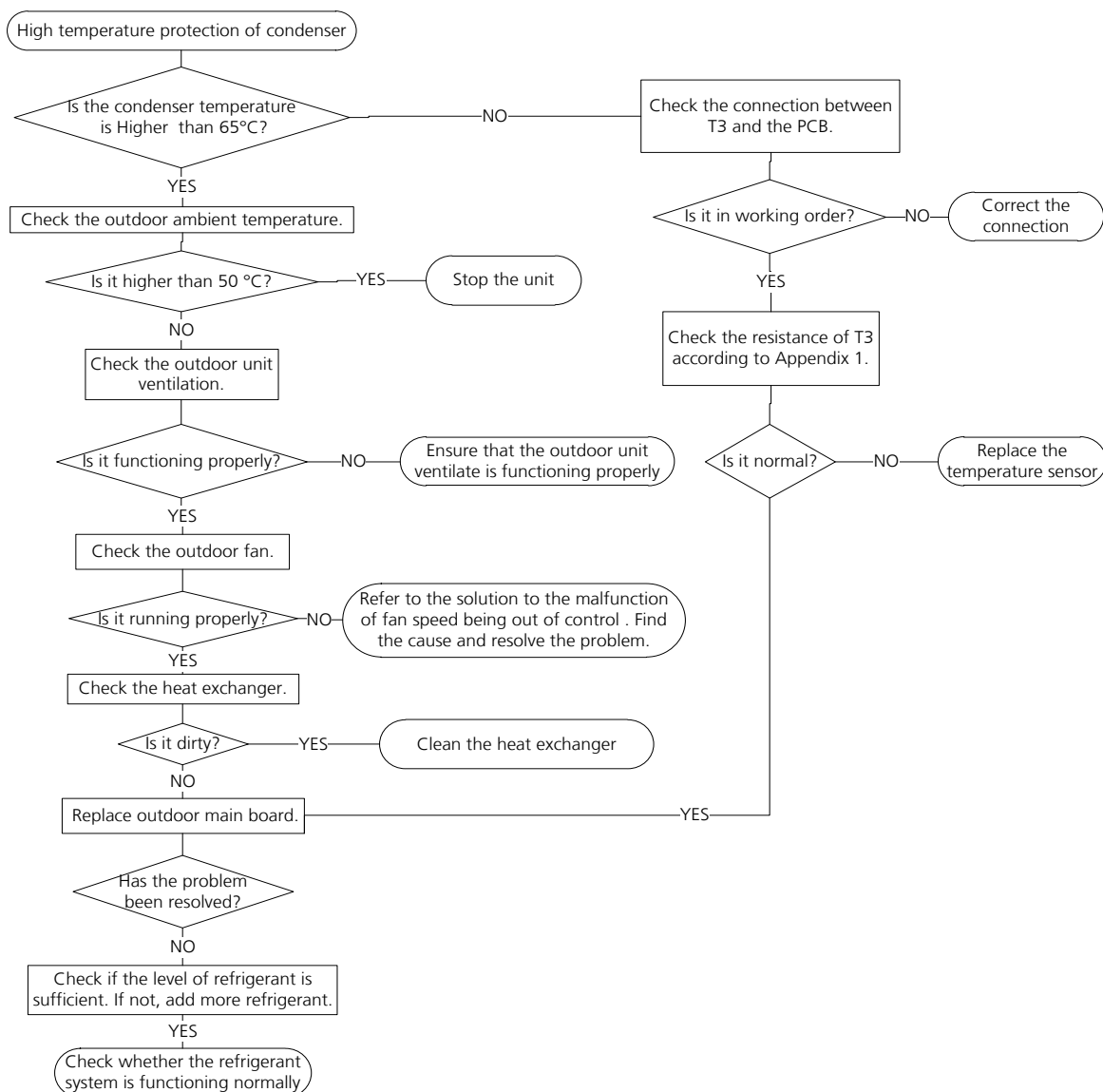

8.17 J2 (High discharge temperature protection)

Description: When the compressor discharge temperature (T5) is more than 115°C for 10 seconds, the compressor will stop and not restart until T5 is less than 90°C.

Recommended parts to prepare:

- Refrigerant
- Wiring
- Discharge temperature sensor
- Outdoor PCB

Troubleshooting and repair:

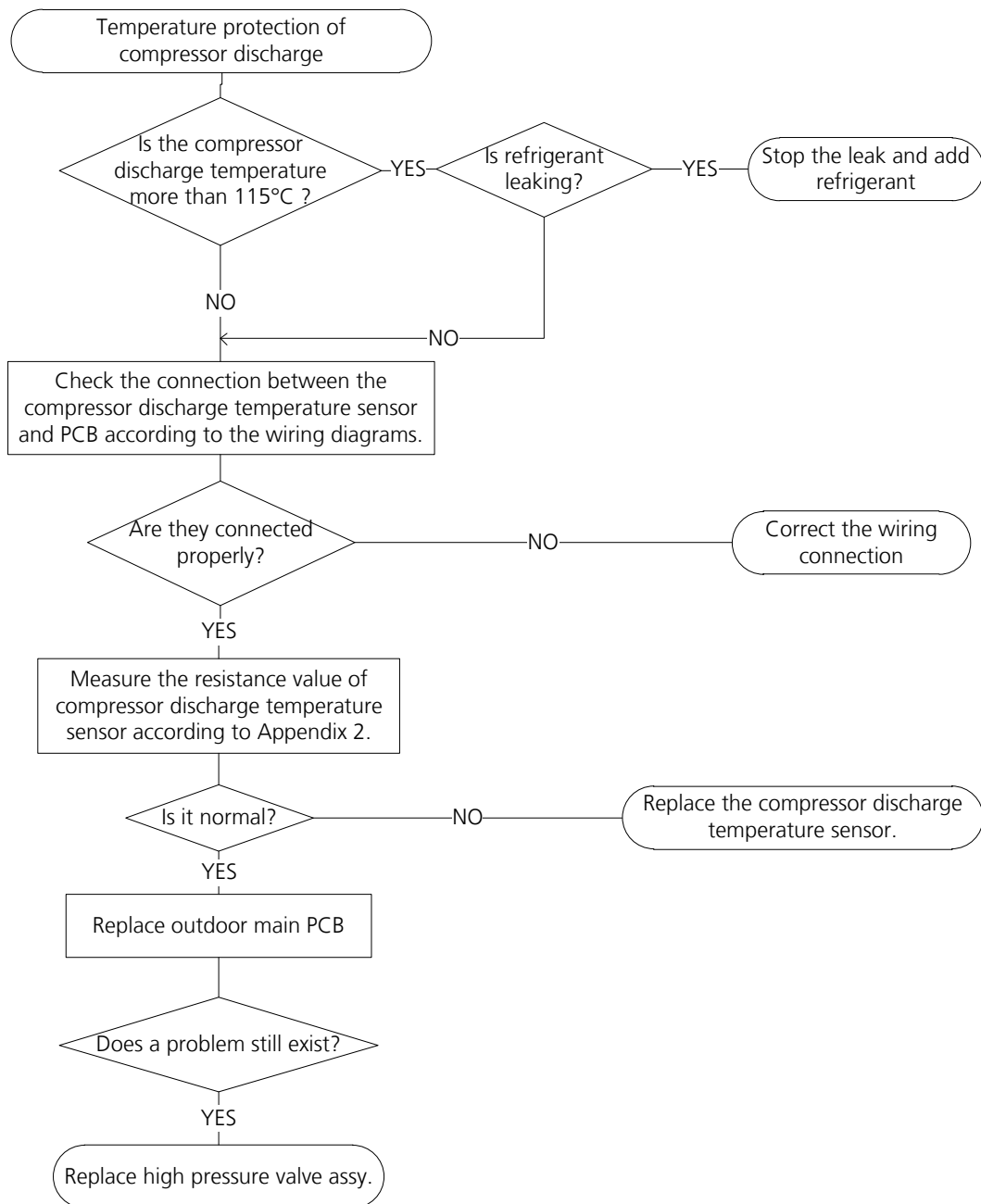

8.18 J3 (PFC module protection)

Description: When the voltage signal that IPM send to compressor drive chip is abnormal, the display LED will show "J3" and AC will turn off.

Recommended parts to prepare:

- Wiring
- IPM board
- Outdoor fan assembly
- Compressor
- Outdoor PCB

Troubleshooting and repair:

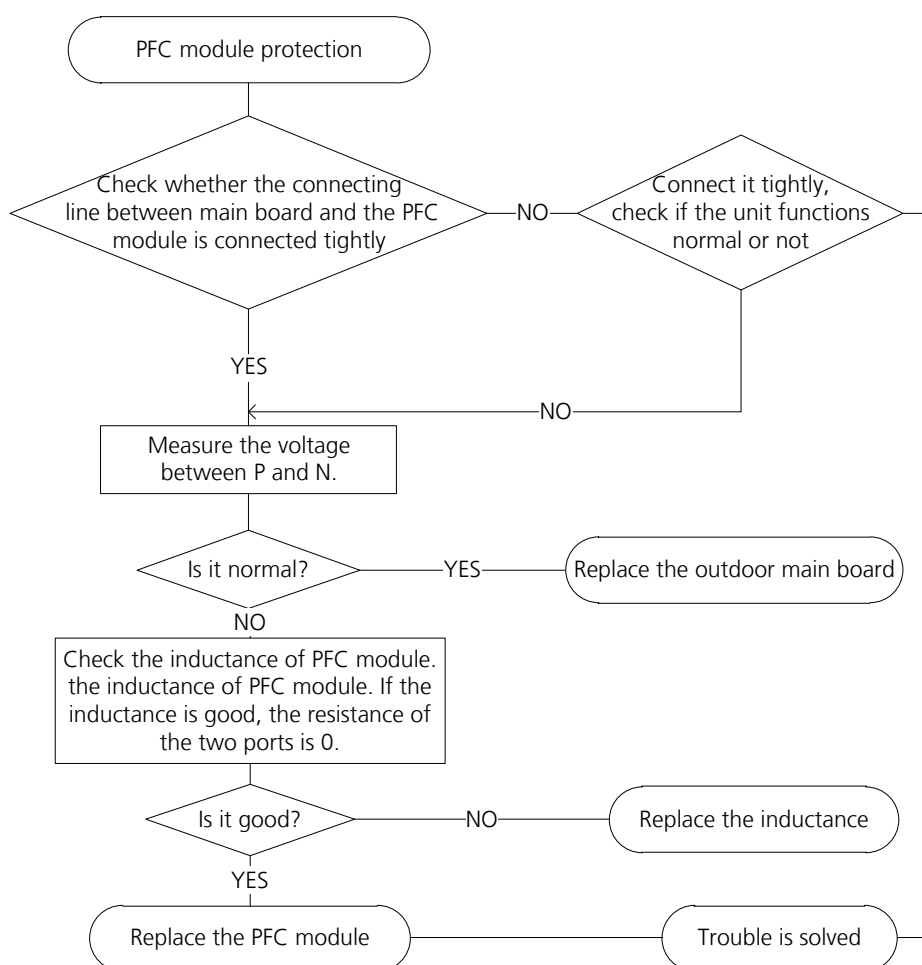

8.19 J4 (Communication error between outdoor main chip and compressor driven chip)

Description: The main PCB has not received feedback from the driven chip for 1 minute or the feedback data is wrong; The driven chip has not received feedback from the main PCB for 1 minute or the feedback data is wrong. The failure code disappears after the compressor stops or the communication runs well.

Recommended parts to prepare:

- Outdoor PCB
- Compressor driven chip
- The signal wire

Troubleshooting and repair:

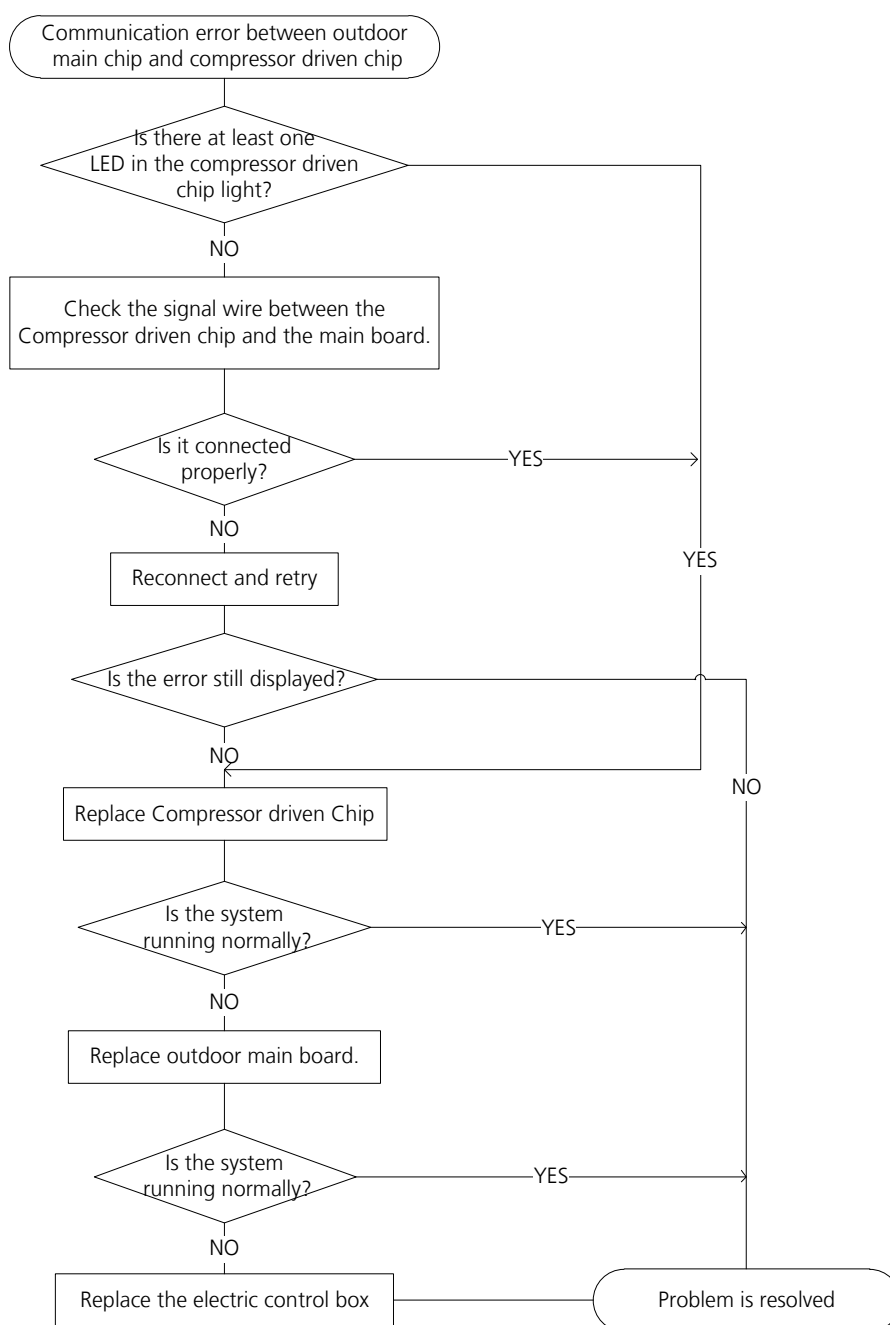

8.20 J5 (High pressure protection)

Description: If the sampling voltage is not 5V, the LED displays a failure code.

Recommended parts to prepare:

- Wiring
- Overload protector
- Outdoor PCB

Troubleshooting and repair:

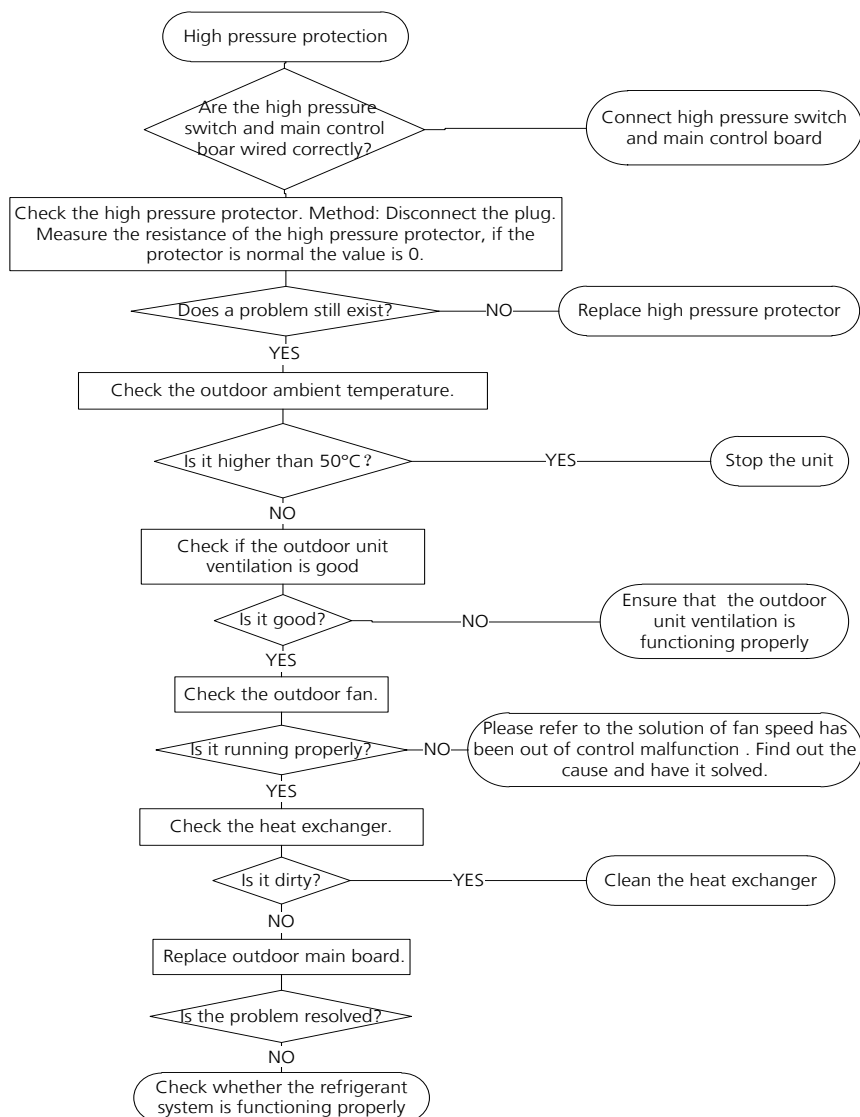

8.21 J8 (AC power input voltage protection)

Description: An abnormal voltage rise or drop is detected by checking the specified voltage detection circuit.

Recommended parts to prepare:

- Wiring
- Bridge rectifier
- IPM board

Troubleshooting and repair:

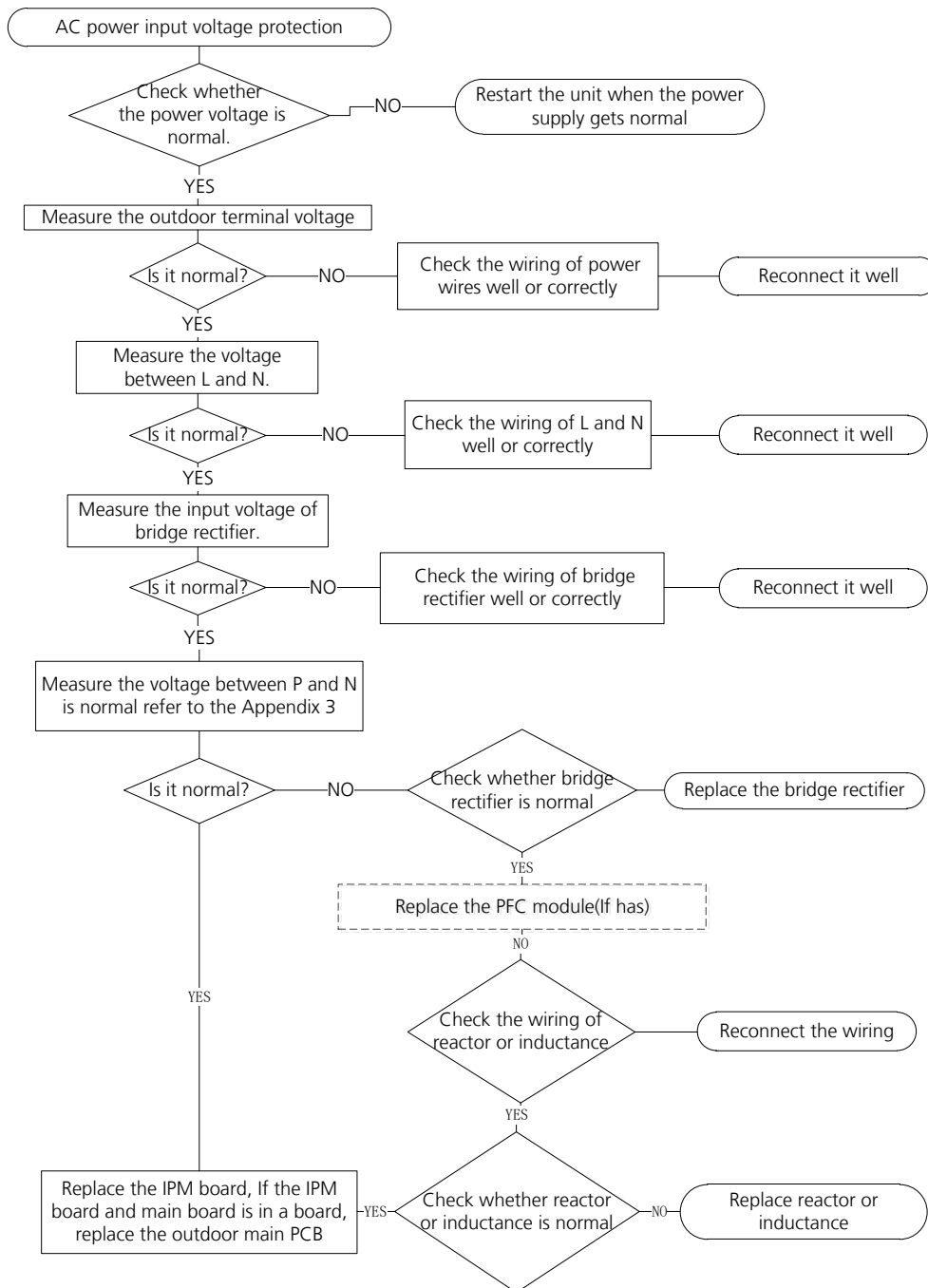

8.22 P5(Indoor units mode conflict (match with multi outdoor unit))

Description: The indoor units cannot work cooling mode and heating at same time. Heating mode has a priority.

- Suppose Indoor unit A working in cooling mode or fan mode, and indoor unit B is set to heating mode, then A will change to off and B will work in heating mode.
- Suppose Indoor unit A working in heating mode, and indoor unit B is set to cooling mode or fan mode, then B will change to stand by and A will be no change.

	Cooling mode	Heating Mode	Fan	Off
Cooling mode	No	Yes	No	No
Heating Mode	Yes	No	Yes	No
Fan	No	Yes	No	No
Off	No	No	No	No

Note:

No: No mode conflict

Yes: Mode conflict

9. Check Procedures

9.1 Temperature Sensor Check

! WARNING

Be sure to turn off all power supplies or disconnect all wires to avoid electric shock. Operate after compressor and coil have returned to normal temperature in case of injury.

1. Disconnect temperature sensor from PCB (Refer to Chapter 5. Indoor Disassembly and Chapter 6. Outdoor Disassembly).
2. Measure the resistance value of the sensor using a multi-meter.
3. Check corresponding temperature sensor resistance value table (Refer to Chapter 8. Appendix).

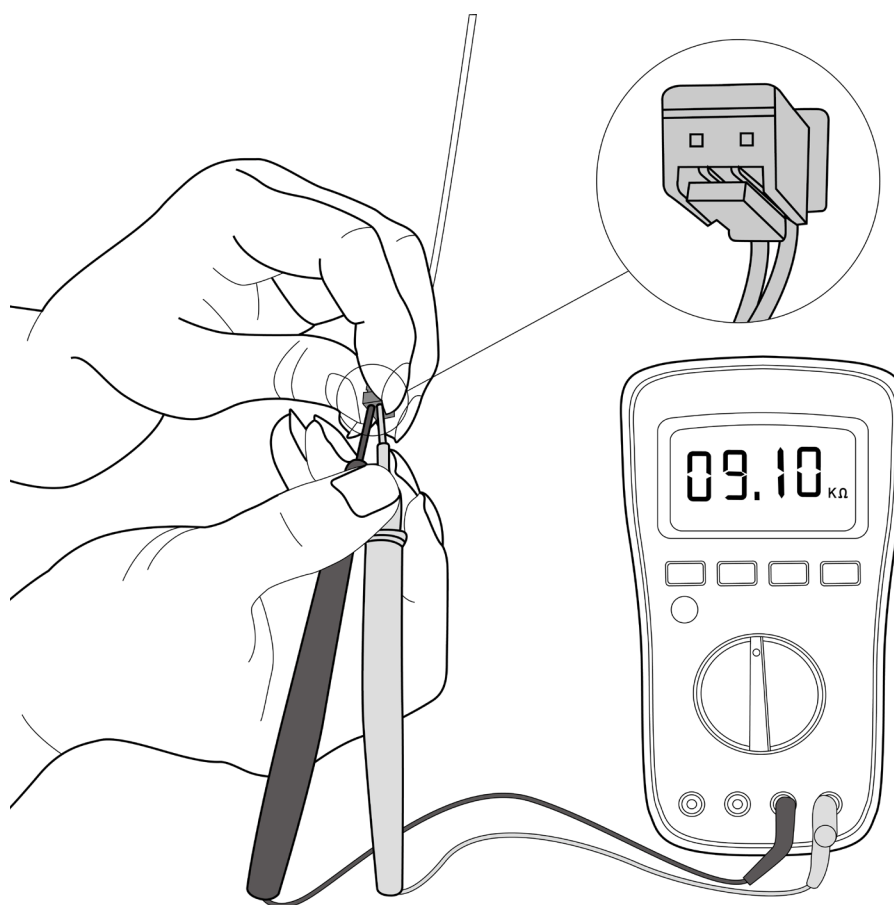

Note: The picture and the value are only for reference, actual condition and specific value may vary.

9.2 Compressor Check

1. Disconnect the compressor power cord from outdoor PCB (Refer to Chapter 6. Outdoor Unit Disassembly).
2. Measure the resistance value of each winding using a multi-meter.
3. Check the resistance value of each winding in the following table.

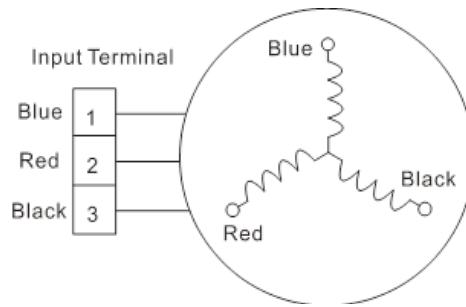

Resistance Value	ASM135D23UFZ	ATQ420D1UMU	ASN98D22UFZ	ATF235D22UMT	ATQ360D1UMU
Blue-Red	1.75Ω	0.37Ω	1.57Ω	0.75Ω	0.37Ω
Blue-Black					
Red-Black					

Resistance Value	ATM115D43UFZ2	ATF250D22UMT	ATF310D43UMT	KSK103D33UEZ3(YJ)	ASM98D32UFZ
Blue-Red	1.87Ω	0.75Ω	0.65Ω	2.13Ω	2.2Ω
Blue-Black					
Red-Black					

Resistance Value	ASN140D21UFZ	ASK89D29UEZD	KSN140D21UFZ	KTM240D57UMT	KSK103D33UEZ3
Blue-Red	1.28Ω	1.99Ω	1.28Ω	0.62Ω	2.02Ω
Blue-Black					
Red-Black					

Resistance Value	KTF310D43UMT	KTQ420D1UMU	ATN150D30UFZA
Blue-Red	0.65Ω	0.37Ω	1.03Ω
Blue-Black			
Red-Black			

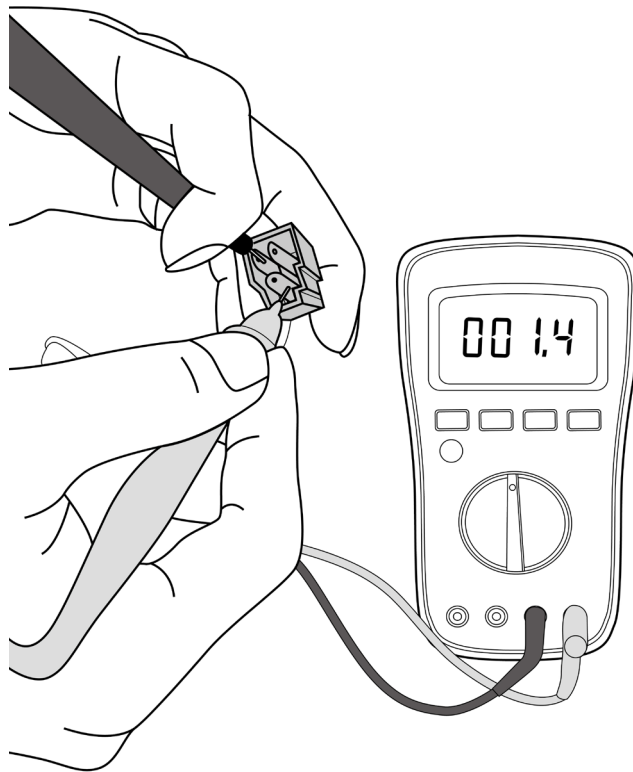

Note: The picture and the value are only for reference, actual condition and specific value may vary.

9.3 IPM Continuity Check

! WARNING

Electricity remains in capacitors even when the power supply is off. Ensure the capacitors are fully discharged before troubleshooting.

1. Turn off outdoor unit and disconnect power supply.
2. Discharge electrolytic capacitors and ensure all energy-storage unit has been discharged.
3. Disassemble outdoor PCB or disassemble IPM board.
4. Measure the resistance value between P and U(V, W, N); U(V, W) and N.

Digital tester		Resistance value	Digital tester		Resistance value
(+)Red	(-)Black	∞ (Several MΩ)	(+)Red	(-)Black	∞ (Several MΩ)
P	N		U	N	
	U		V		
	V		W		
	W		-		

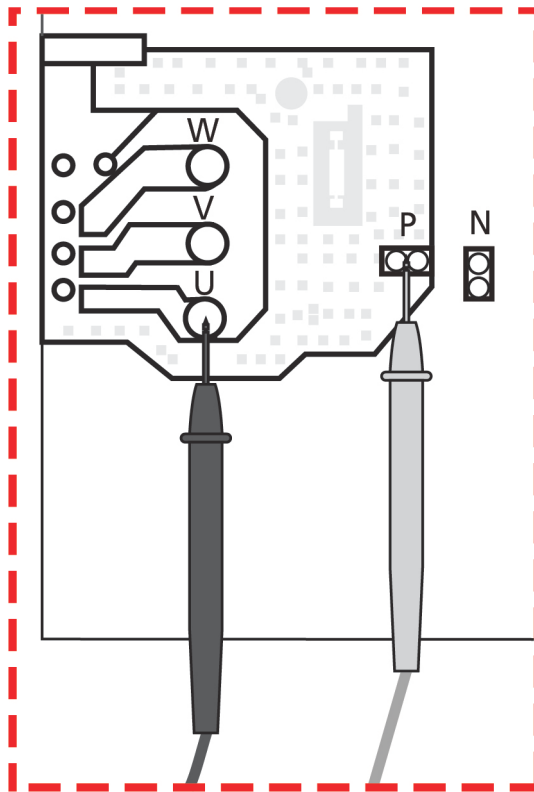

Note: The picture and the value are only for reference, actual condition and specific value may vary.

Normal voltage of P and N

208-240V(1-phase,3-phase)		380-415V(3-phase)	
In standby			
around 310VDC		around 530VDC	
In operation			
With passive PFC module	With partial active PFC module	With fully active PFC module	/
>200VDC	>310VDC	>370VDC	>450VDC

Indoor Unit Disassembly-Air Handle

Contents

- 1. Indoor Unit Disassembly1**
 - 1.1 Electrical Parts2
 - 1.2 Filter.....4
 - 1.3 Fan Motor and Fan5
 - 1.4 Evaporator.....7

1. Indoor Unit Disassembly

1.1 Electrical Parts (Antistatic gloves must be worn.)

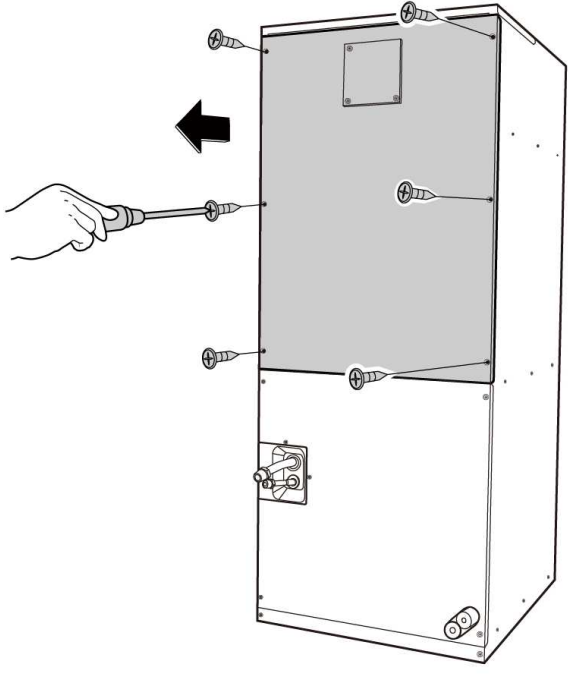
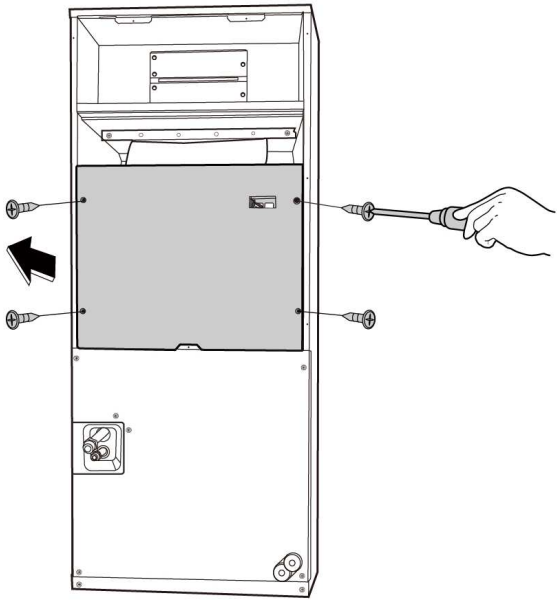
Procedure	Illustration
<p>1) Remove 6 screws of the upside board and then remove the upside plate. (see CJ_AHU_001)</p>	 <p>CJ_AHU_001</p>
<p>2) Remove 4 screws of electric control box cover and then remove it.(see CJ_AHU_002)</p>	 <p>CJ_AHU_002</p>

Note: This section is for reference only. Actual unit appearance may vary.

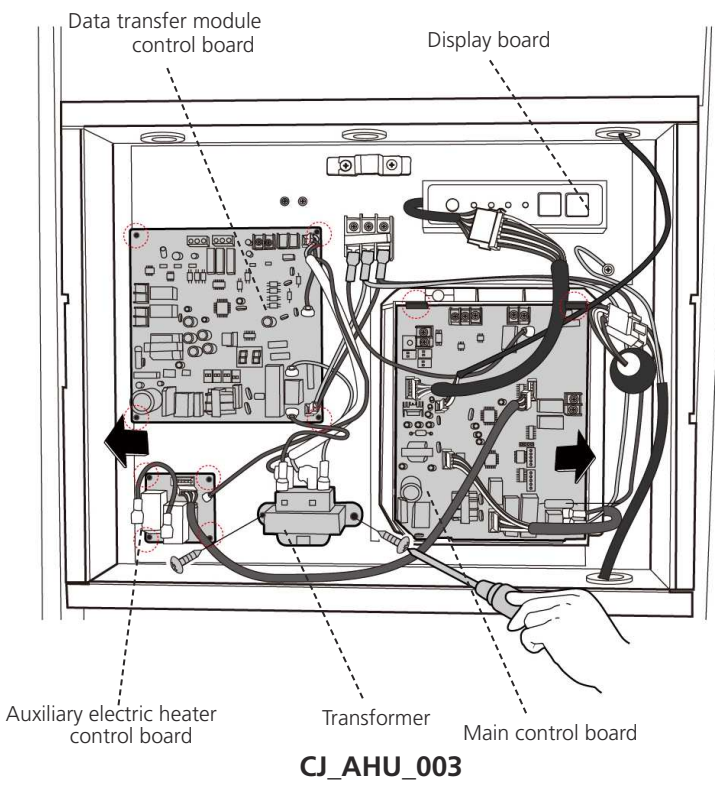
Procedure	Illustration
<p>3) Release 2 hooks of the main control board to remove it. (see CJ_AHU_003)</p> <p>4) Release 4 hooks of the data transfer module control board to remove it. (see CJ_AHU_003)</p> <p>5) Release 4 hooks of the auxiliary electric heater control board to remove it. (see CJ_AHU_003)</p> <p>6) Release 2 screws and then remove the transformer. (see CJ_AHU_003)</p>	 <p style="text-align: center;">CJ_AHU_003</p>

Note: This section is for reference only. Actual unit appearance may vary.

1.2 Filter

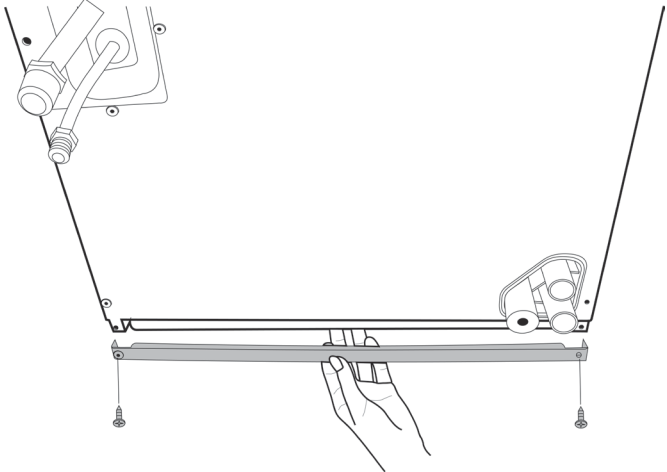
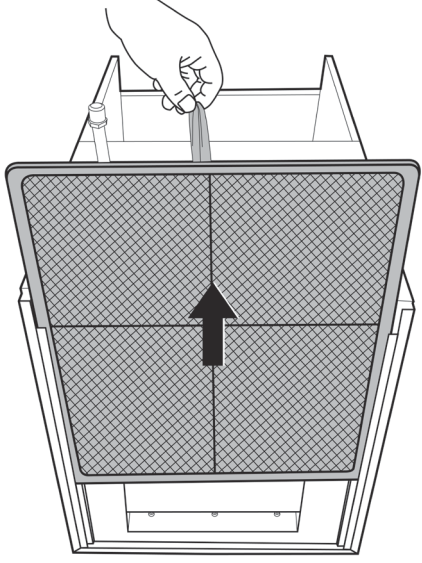
Procedure	Illustration
<p>1) Remove 2 screws of Supporting bar (see CJ_AHU_003)</p>	 <p>The diagram shows a hand pulling a horizontal supporting bar out from the bottom of the AHU unit. The bar is held in place by two screws at the top corners. The unit's internal components, including a fan and motor, are visible above the bar.</p> <p style="text-align: center;">CJ_AHU_004</p>
<p>2) Pull out the filter (see CJ_AHU_004)</p>	 <p>The diagram shows a hand pulling a rectangular filter out of a compartment. The filter is held in place by a metal frame. An upward-pointing arrow indicates the direction of removal.</p> <p style="text-align: center;">CJ_AHU_004</p>

Note: This section is for reference only. Actual unit appearance may vary.

1.3 Fan Motor and Fan

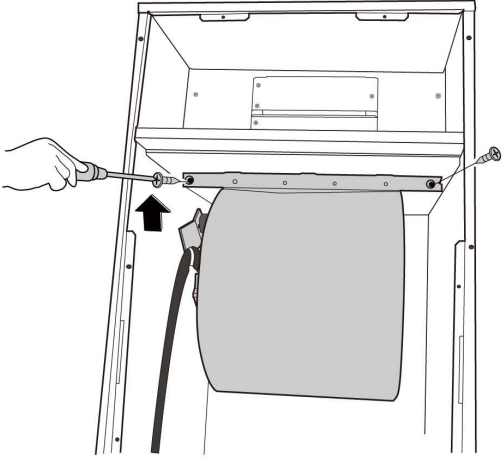
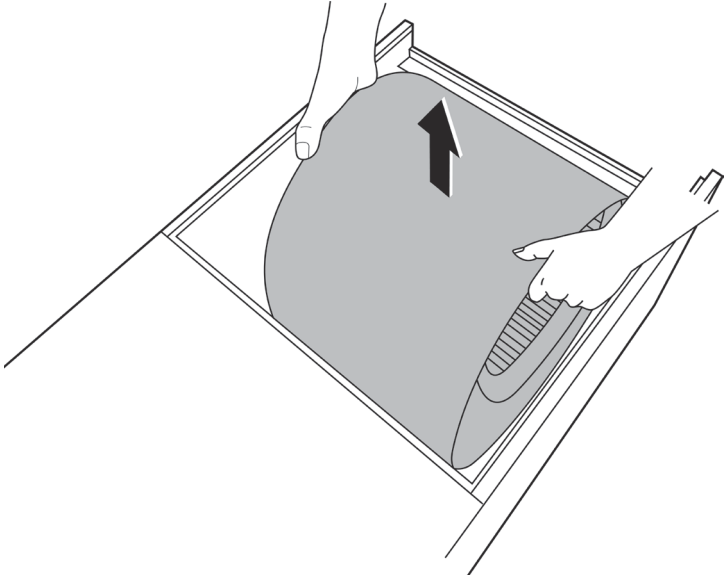
Procedure	Illustration
<p>1) Remove 2 screws of fan assembly (see CJ_AHU_005)</p>	 <p>CJ_AHU_005</p>
<p>2) Take out the fan assembly (see CJ_AHU_006)</p>	 <p>CJ_AHU_006</p>

Note: This section is for reference only. Actual unit appearance may vary.

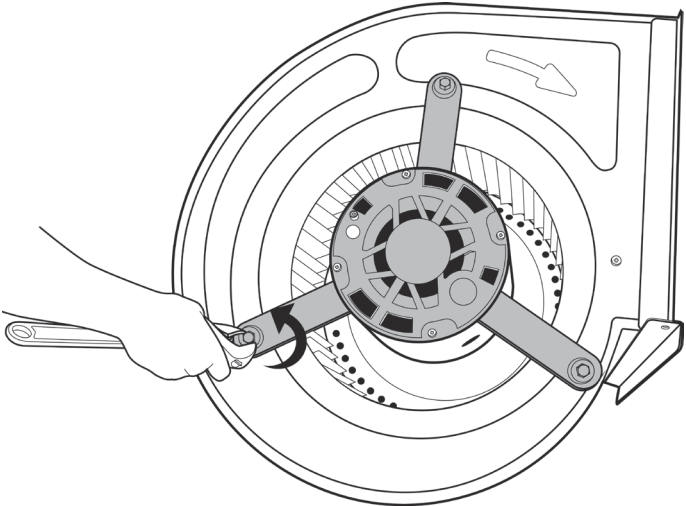
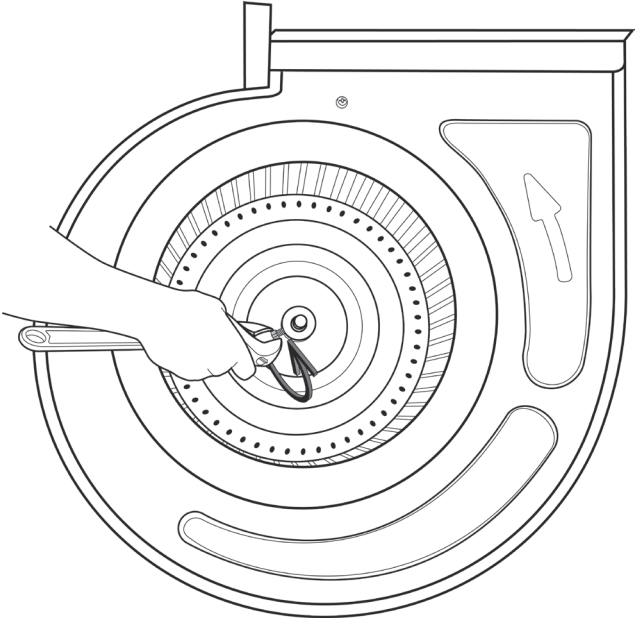
Procedure	Illustration
<p>3) Release 3 nuts fixing the fan motor and then take out the fan motor. (see CJ_AHU_007)</p>	 <p style="text-align: center;">CJ_AHU_007</p>
<p>4) Release the 1 nut fixing the fan and then take out the fan. (see CJ_AHU_008)</p>	 <p style="text-align: center;">CJ_AHU_008</p>

Note: This section is for reference only. Actual unit appearance may vary.

1.4 Evaporator

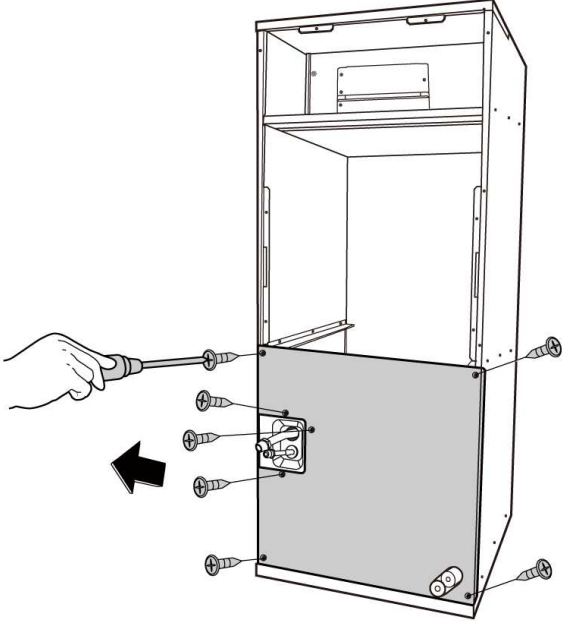
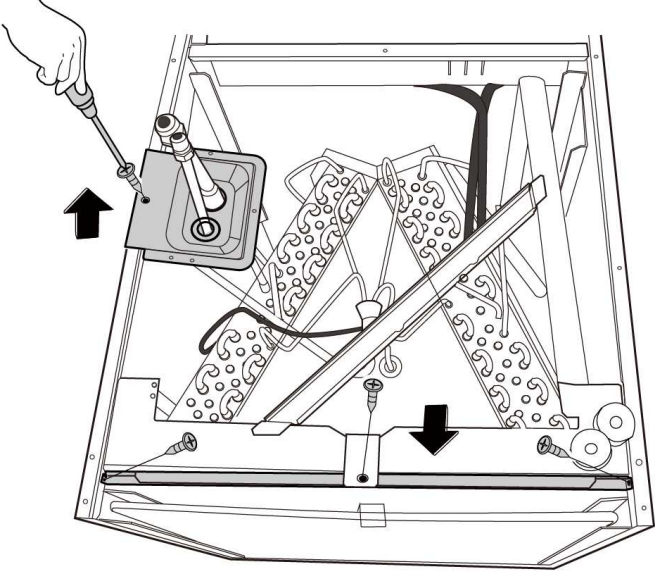
Procedure	Illustration
<p>1) Remove 7 screws of side plate(below) (see CJ_AHU_009)</p>	 <p>The diagram shows a hand using a screwdriver to remove screws from a side plate. A black arrow points to the left, indicating the direction of removal. The side plate is a rectangular panel attached to the side of the indoor unit's metal frame.</p> <p style="text-align: center;">CJ_AHU_009</p>
<p>2) Remove 1 screw of pipe clamp board and 3 screw of rear support board (see CJ_AHU_010)</p>	 <p>The diagram shows a hand using a screwdriver to remove screws from the interior of the indoor unit. A black arrow points upwards, indicating the removal of a screw from a pipe clamp board. Another black arrow points downwards, indicating the removal of screws from the rear support board. The evaporator coils and other internal components are visible.</p> <p style="text-align: center;">CJ_AHU_010</p>

Note: This section is for reference only. Actual unit appearance may vary.

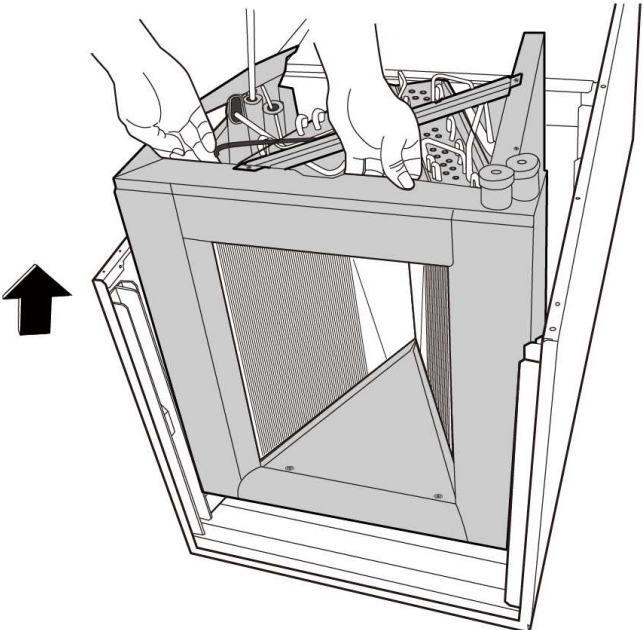
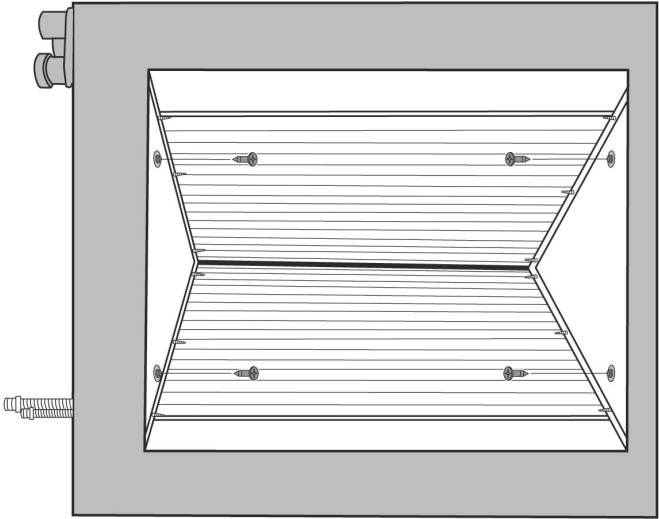
Procedure	Illustration
<p>3) Take out the evaporator(with water collector assembly). (see CJ_AHU_011)</p>	 <p style="text-align: center;">CJ_AHU_011</p>
<p>4) Remove 4 screws of water collector assembly.(see CJ_AHU_012)</p>	 <p style="text-align: center;">CJ_AHU_012</p>

Note: This section is for reference only. Actual unit appearance may vary.

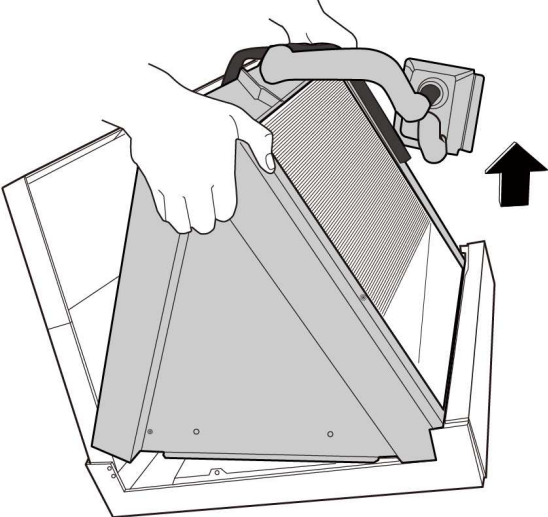
Procedure	Illustration
<p>5) Release evaporator and the water collector assembly. (see CJ_AHU_013)</p>	 <p>CJ_AHU_013</p>

Note: This section is for reference only. Actual unit appearance may vary.

Outdoor Unit Disassembly

Contents

1.	Outdoor Unit Table	2
2.	Outdoor Unit Disassembly	3
2.1	Panel Plate.....	3
2.2	Electrical Parts	22
2.3	Fan Assembly	44
2.4	Fan Motor	45
2.5	Sound Blanket.....	46
2.6	Four-way Valve	47
2.7	Compressor.....	48

1. Outdoor Unit Disassembly

1.1 Outdoor Unit Table

Outdoor Unit Model	Panel Plate	PCB Board
MOD31-24HFN1-MT0W	D30	PCB Board 5
MOD01-23HFN1-MT0W	D30	PCB Board 8
MOD30-24HFN1-MT0W	D30	PCB Board 8
MOD30-24HFN1-MU0W	D30	PCB Board 13
MOD30U-36HFN1-M	D30	PCB Board 13
MOE30U-48HFN1-M	E30	PCB Board 11

2. Outdoor Unit Disassembly

2.1 Panel Plate

1. BA30

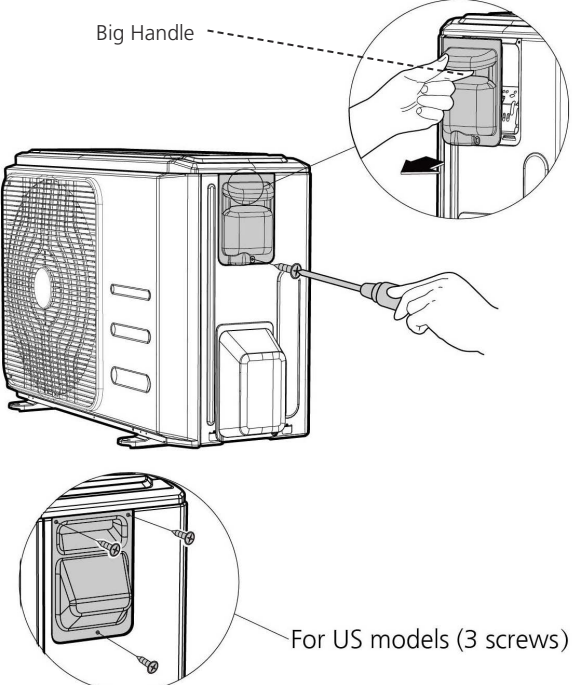
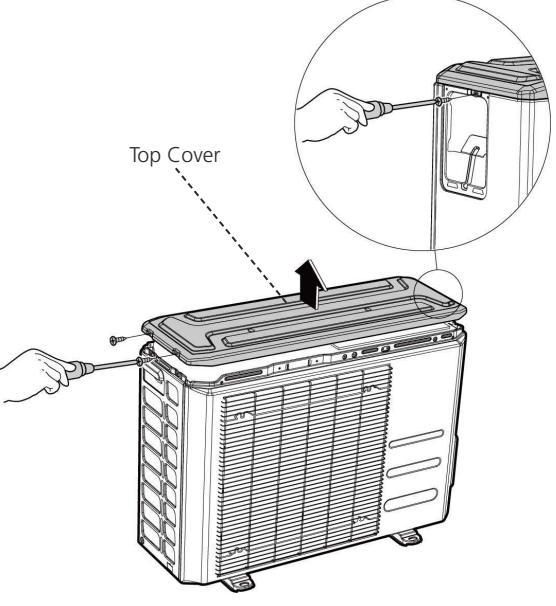
Procedure	Illustration
<p>1) Turn off the air conditioner and the power breaker.</p> <p>2) Remove the screws of the big handle and then remove the big handle (1 screws) (see CJ_BA30_001).</p>	 <p>Big Handle</p> <p>For US models (3 screws)</p> <p>CJ_BA30_001</p>
<p>3) Remove the screws of the top cover and then remove the top cover (3 screws). One of the screws is located underneath the big handle (see CJ_BA30_002).</p>	 <p>Top Cover</p> <p>CJ_BA30_002</p>

Note: This section is for reference only. Actual unit appearance may vary.

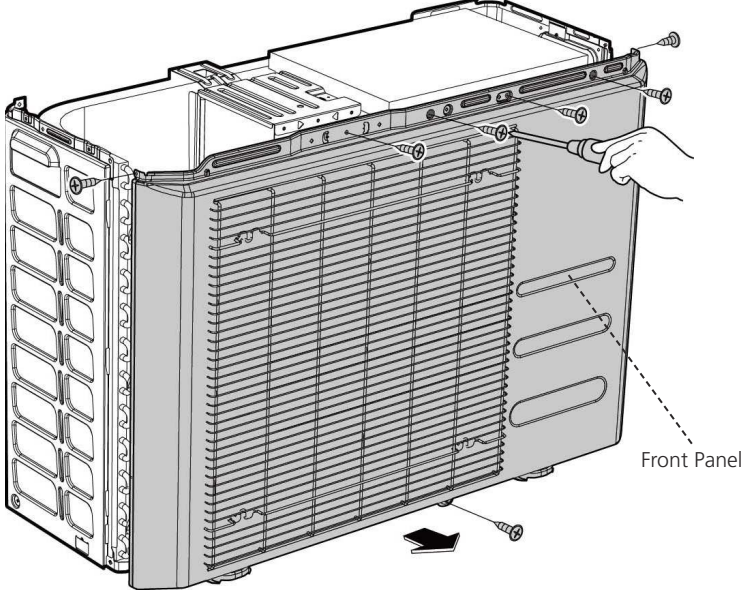
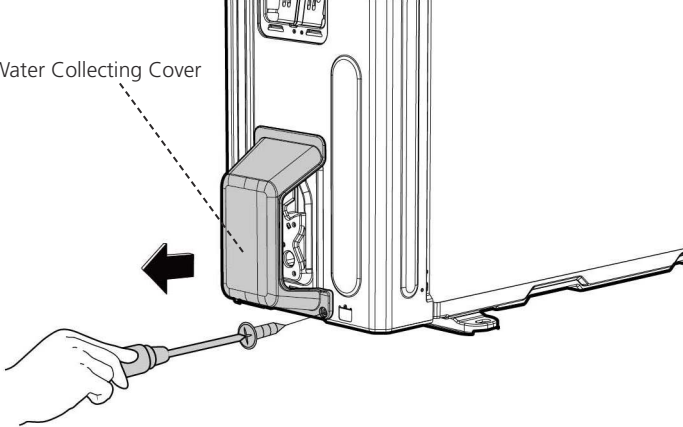
Procedure	Illustration
<p>4) Remove the screws of the front panel and then remove the front panel (7 screws) (see CJ_BA30_003).</p>	 <p style="text-align: center;">CJ_BA30_003</p>
<p>5) Remove the screws of water collecting cover (1 screw) (see CJ_BA30_004).</p>	 <p style="text-align: center;">CJ_BA30_004</p>

Note: This section is for reference only. Actual unit appearance may vary.

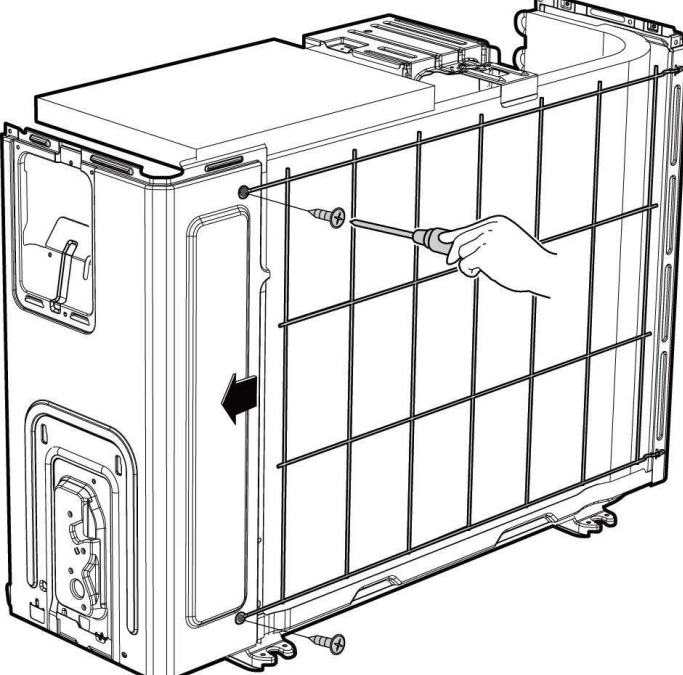
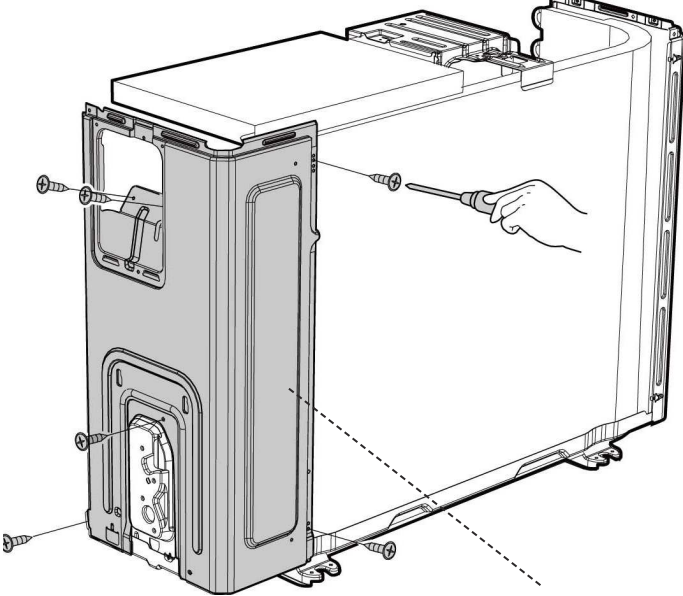
Procedure	Illustration
<p>6) Remove the screws of the rear net and then remove the rear net (2 screws) (see CJ_BA30_005). (for some models)</p>	 <p style="text-align: center;">CJ_BA30_005</p>
<p>7) Remove the screws of the right panel and then remove the right panel (6 screws) (see CJ_BA30_006).</p>	 <p style="text-align: right;">Right Panel</p> <p style="text-align: center;">CJ_BA30_006</p>

Note: This section is for reference only. Actual unit appearance may vary.

2. B30

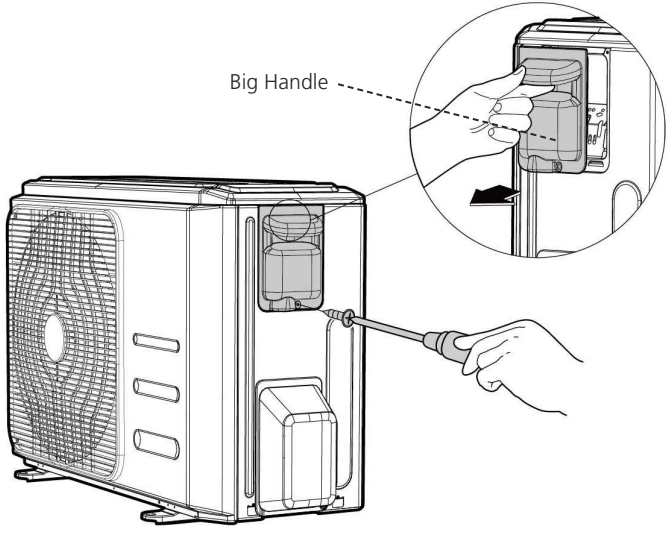
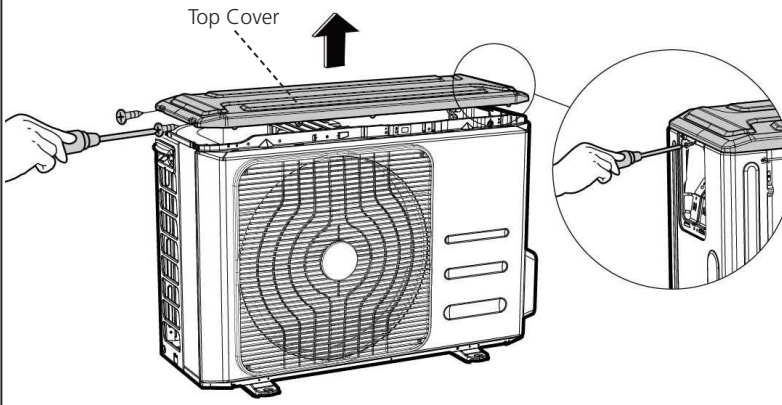
Procedure	Illustration
<p>1) Turn off the air conditioner and the power breaker.</p> <p>2) Remove the screws of the big handle and then remove the big handle (1 screws) (see CJ_B30_001).</p>	 <p>Big Handle</p> <p>For US models (3 screws)</p> <p>CJ_B30_001</p>
<p>3) Remove the screws of the top cover and then remove the top cover (3 screws). One of the screws is located underneath the big handle (see CJ_B30_002).</p>	 <p>Top Cover</p> <p>CJ_B30_002</p>

Note: This section is for reference only. Actual unit appearance may vary.

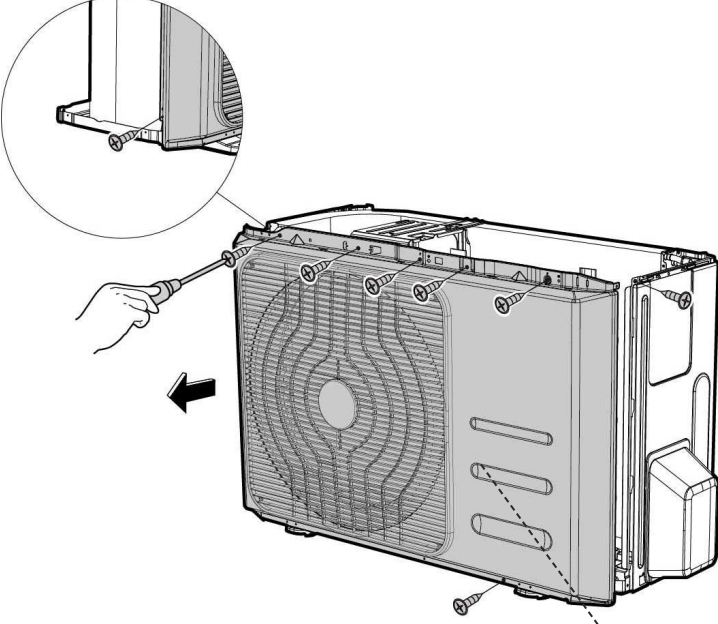
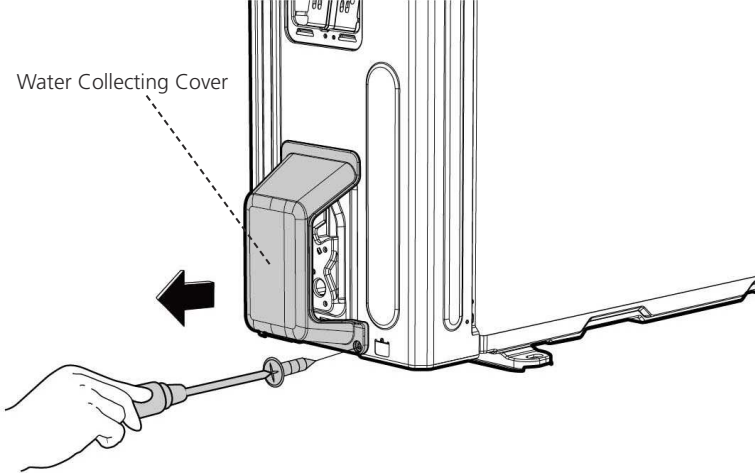
Procedure	Illustration
<p>4) Remove the screws of the front panel and then remove the front panel (8 screws) (see CJ_B30_003).</p>	 <p style="text-align: center;">CJ_B30_003</p>
<p>5) Remove the screws of water collecting cover and then remove the water collecting cover (1 screw) (see CJ_B30_004).</p>	 <p style="text-align: center;">CJ_B30_004</p>

Note: This section is for reference only. Actual unit appearance may vary.

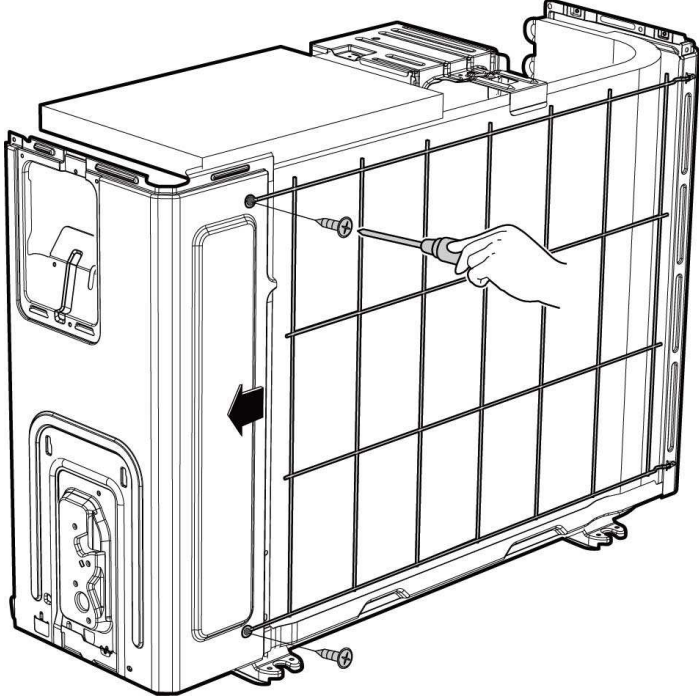
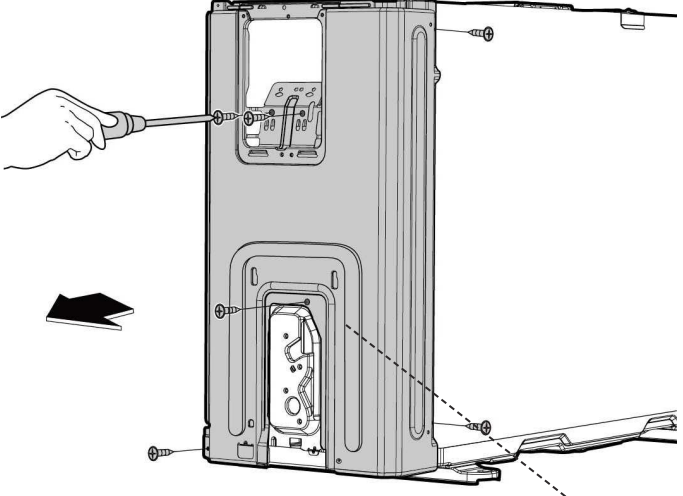
Procedure	Illustration
<p>6) Remove the screws of the rear net and then remove the rear net (2 screws) (see CJ_B30_005). (for some models)</p>	 <p style="text-align: center;">CJ_B30_005</p>
<p>7) Remove the screws of the right panel and then remove the right panel (5 screws) (see CJ_B30_006).</p>	 <p style="text-align: center;">CJ_B30_006</p> <p style="text-align: right;">Right Panel</p>

Note: This section is for reference only. Actual unit appearance may vary.

3. CA30

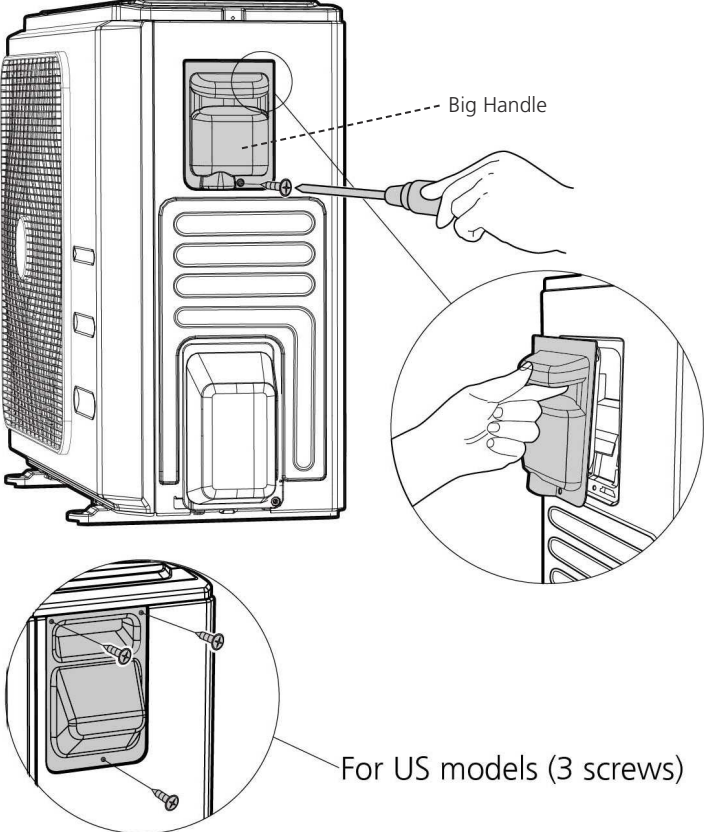
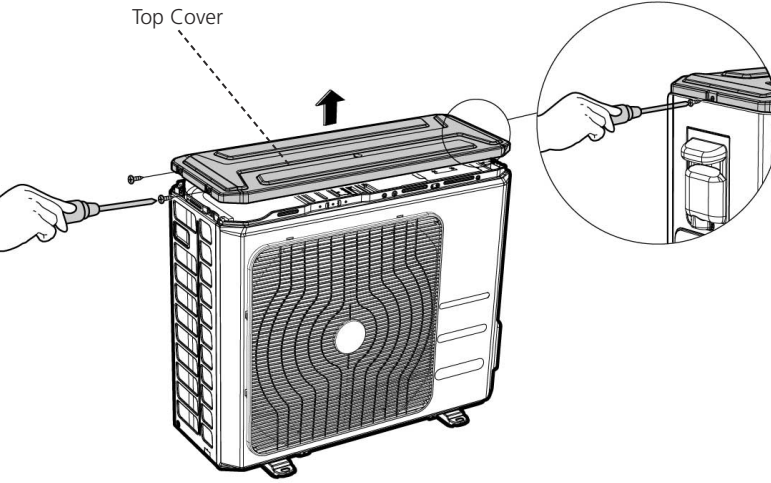
Procedure	Illustration
<p>1) Turn off the air conditioner and the power breaker.</p> <p>2) Remove the screws of the big handle and then remove the big handle (1 screws) (see CJ_CA30_001).</p>	 <p data-bbox="925 1317 1101 1355">CJ_CA30_001</p>
<p>3) Remove the screws of the top cover and then remove the top cover (3 screws). One of the screws is located underneath the big handle (see CJ_CA30_002).</p>	 <p data-bbox="925 1915 1101 1953">CJ_CA30_002</p>

Note: This section is for reference only. Actual unit appearance may vary.

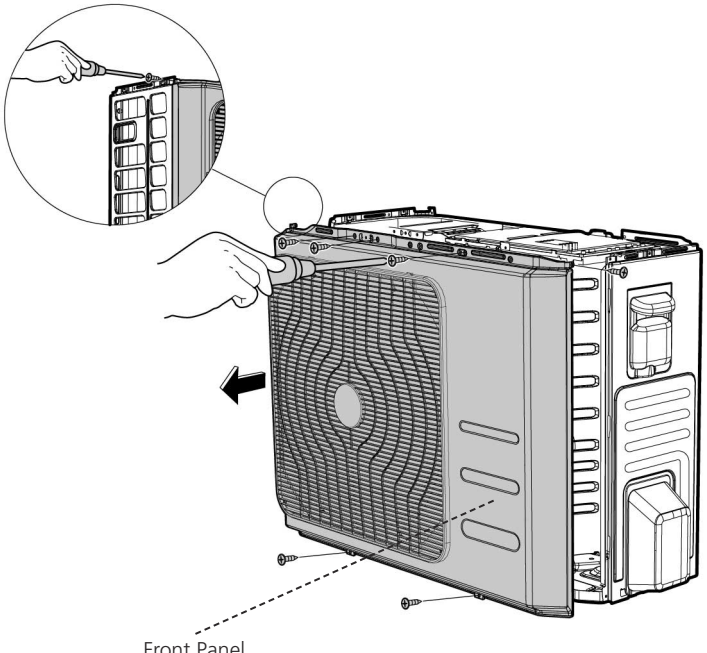
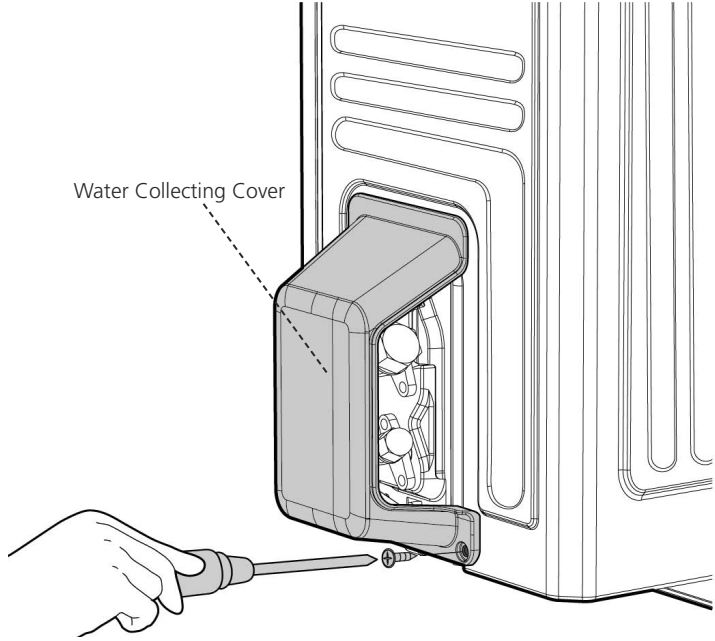
Procedure	Illustration
<p>4) Remove the screws of the front panel and then remove the front panel (7 screws) (see CJ_CA30_003).</p>	 <p style="text-align: center;">CJ_CA30_003</p>
<p>5) Remove the screws of water collecting cover and then remove the water collecting cover (1 screw) (see CJ_CA30_004).</p>	 <p style="text-align: center;">CJ_CA30_004</p>

Note: This section is for reference only. Actual unit appearance may vary.

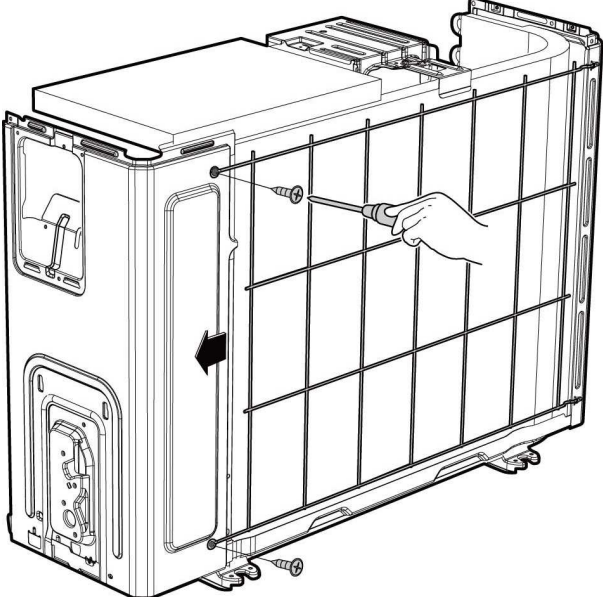
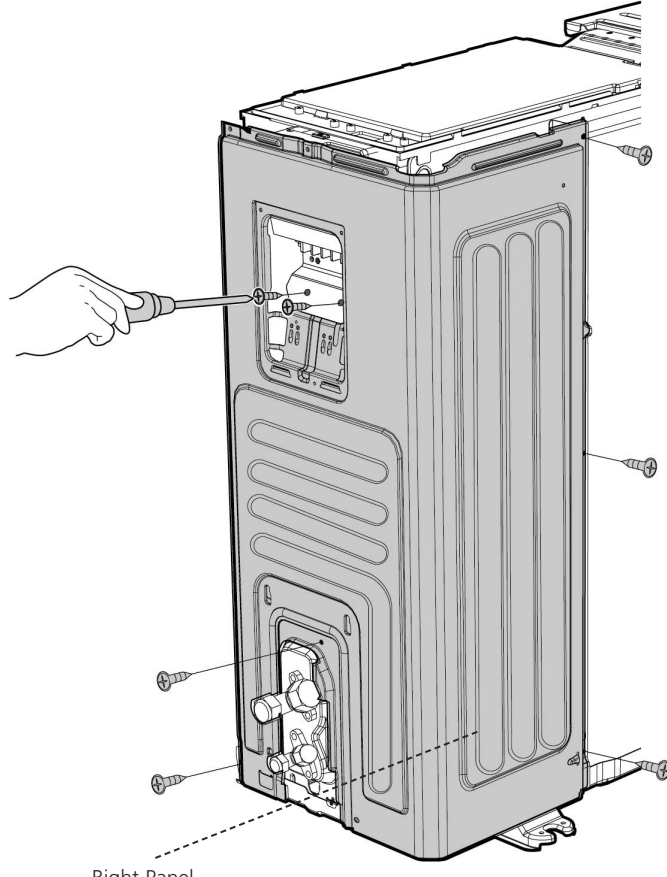
Procedure	Illustration
<p>6) Remove the screws of the rear net and then remove the rear net (2 screws) (see CJ_CA30_005). (for some models)</p>	 <p style="text-align: center;">CJ_CA30_005</p>
<p>7) Remove the screws of the right panel and then remove the right panel (7 screws) (see CJ_CA30_006).</p>	 <p style="text-align: center;">CJ_CA30_006</p>

Note: This section is for reference only. Actual unit appearance may vary.

4. D30

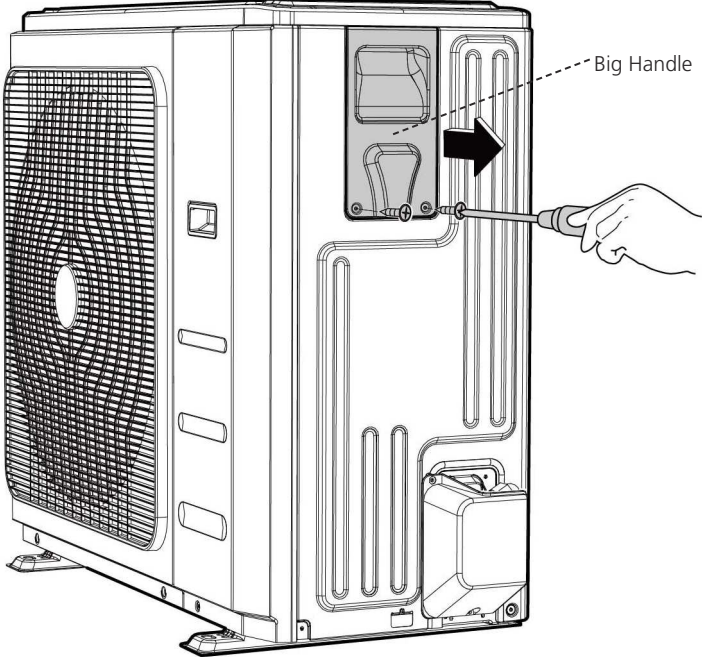
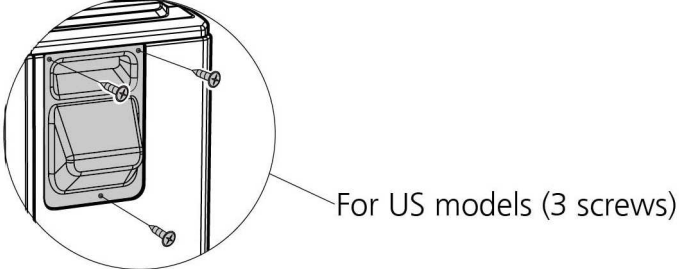
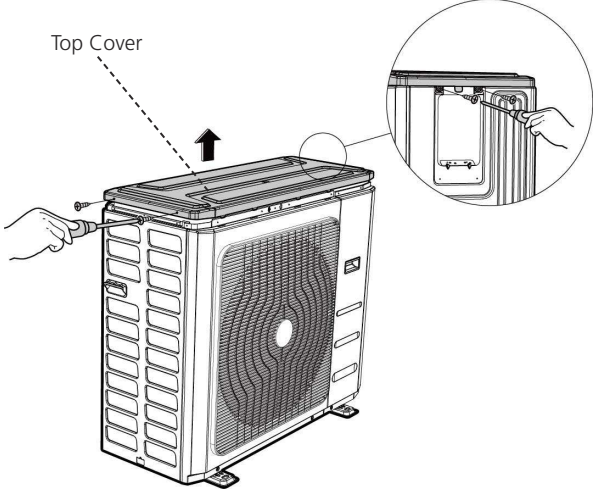
Procedure	Illustration
<p>1) Turn off the air conditioner and the power breaker.</p> <p>2) Remove the screws of the big handle and then remove the big handle (2 screws) (see CJ_D30_001).</p>	 <p>Big Handle</p>  <p>For US models (3 screws)</p> <p>CJ_D30_001</p>
<p>3) Remove the screws of the top cover and then remove the top cover (4 screws). Two of the screws is located underneath the big handle (see CJ_D30_002).</p>	 <p>Top Cover</p> <p>CJ_D30_002</p>

Note: This section is for reference only. Actual unit appearance may vary.

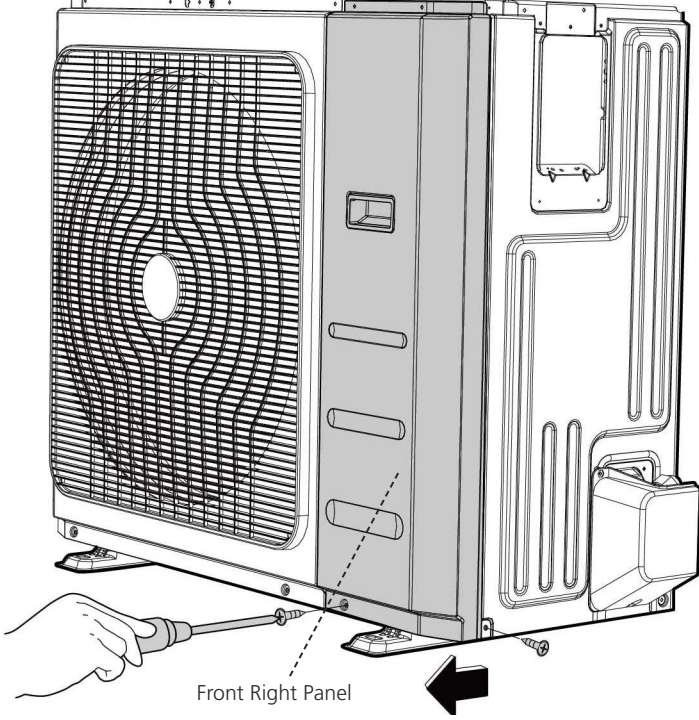
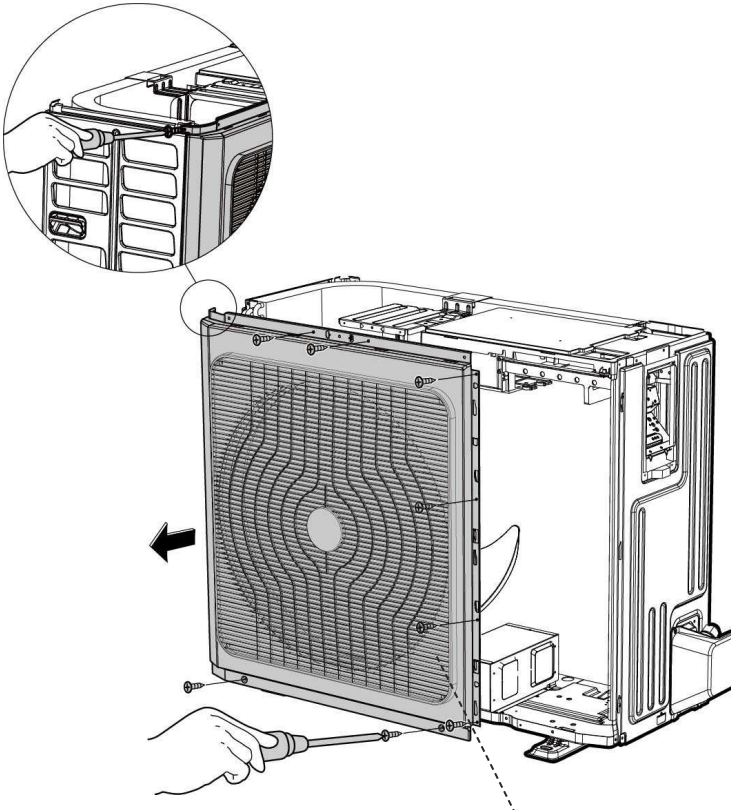
Procedure	Illustration
<p>4) Remove the screws of the front right panel and then remove the front right panel (2 screws) (see CJ_D30_003).</p>	 <p style="text-align: center;">Front Right Panel</p> <p style="text-align: center;">CJ_D30_003</p>
<p>5) Remove the screws of the front panel and then remove the front panel (9 screws) (see CJ_D30_004).</p>	 <p style="text-align: center;">Front Panel</p> <p style="text-align: center;">CJ_D30_004</p>

Note: This section is for reference only. Actual unit appearance may vary.

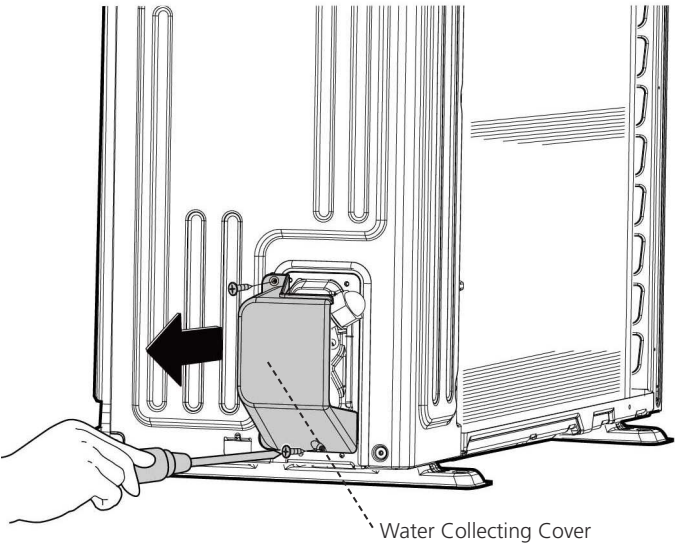
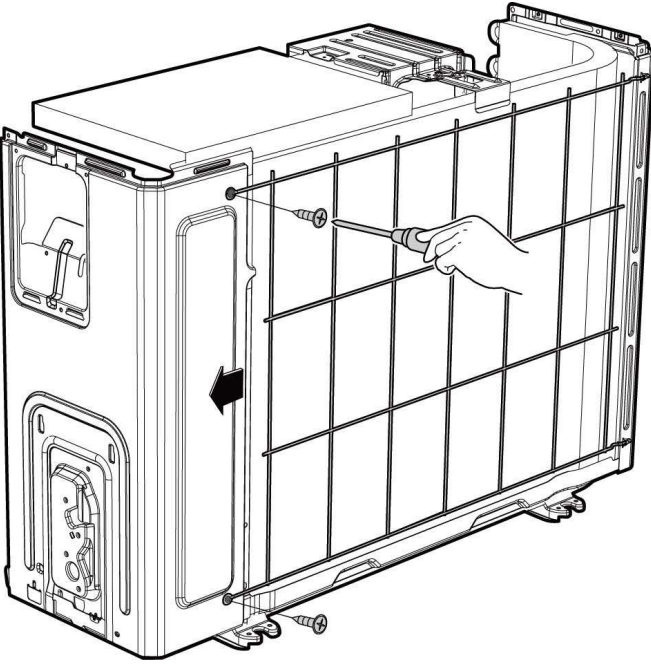
Procedure	Illustration
<p>6) Remove the screws of water collecting cover and then remove the water collecting cover (2 screw) (see CJ_D30_005).</p>	 <p style="text-align: center;">Water Collecting Cover</p> <p style="text-align: center;">CJ_D30_005</p>
<p>7) Remove the screws of the rear net and then remove the rear net (2 screws) (see CJ_D30_006). (for some models)</p>	 <p style="text-align: center;">CJ_D30_006</p>

Note: This section is for reference only. Actual unit appearance may vary.

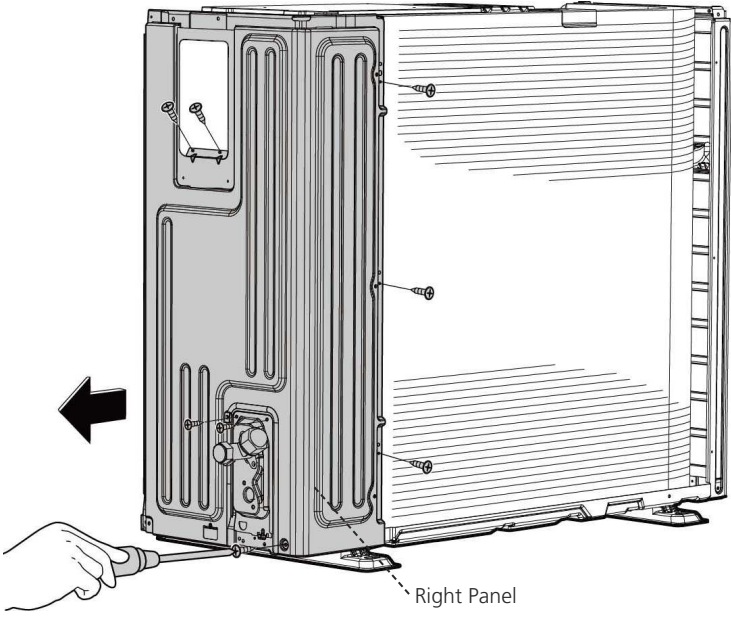
Procedure	Illustration
<p>8) Remove the screws of the right panel and then remove the right panel (8 screws) (see CJ_D30_007).</p>	 <p data-bbox="938 1093 1093 1131">CJ_D30_007</p>

Note: This section is for reference only. Actual unit appearance may vary.

5. X401

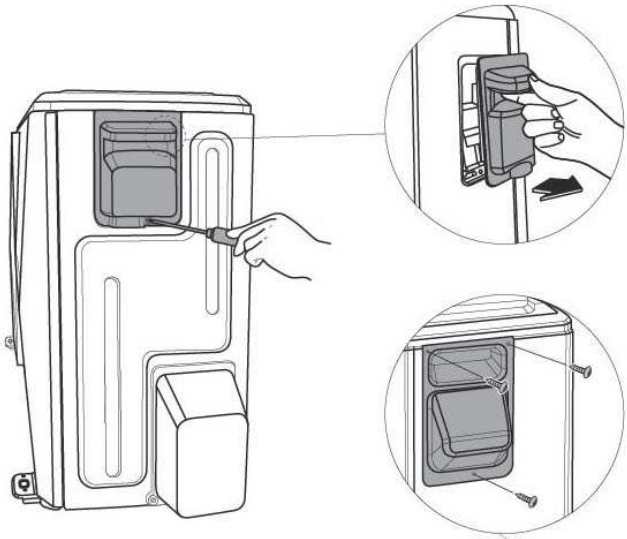
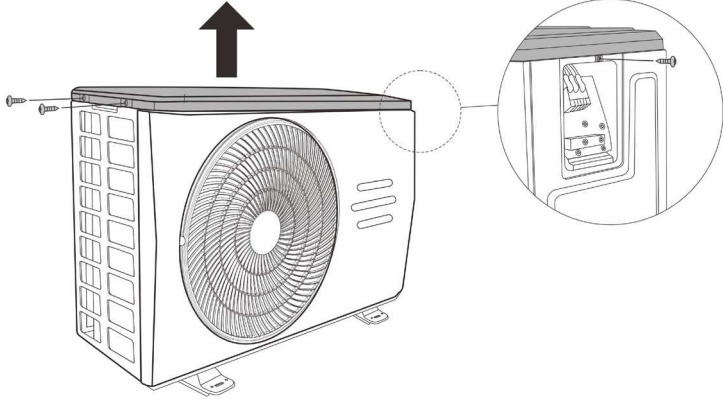
Procedure	Illustration
<p>1) Turn off the air conditioner and the power breaker.</p> <p>2) Remove the screw of the big handle and then remove the big handle (1 screw) (see CJ_X401_001).</p>	 <p data-bbox="1165 936 1348 963">For US models (3 screws)</p> <p data-bbox="925 996 1101 1041">CJ_X401_001</p>
<p>3) Remove the screws of the top cover and then remove the top cover (3 screws). One of the screws is located underneath the big handle (see CJ_X401_002).</p>	 <p data-bbox="925 1758 1101 1803">CJ_X401_002</p>

Note: This section is for reference only. Actual unit appearance may vary.

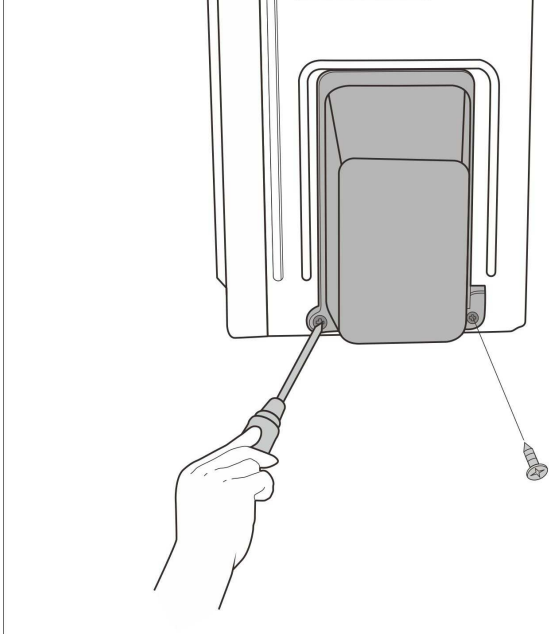
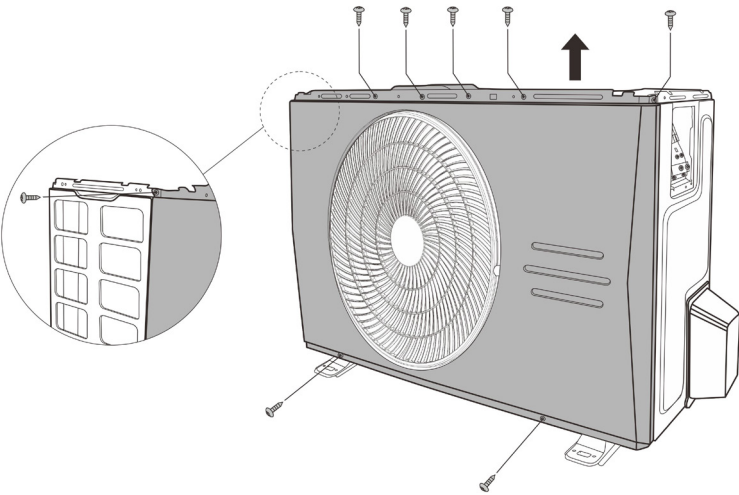
Procedure	Illustration
<p>4) Remove the screws of water collecting cover and then remove the water collecting cover (2 screw) (see CJ_X401_003).</p>	 <p style="text-align: center;">CJ_X401_003</p>
<p>5) Remove the screws of the front panel and then remove the front panel (6 screws(onoff models) or 8 screws(inverter models) (see CJ_X401_004).</p>	 <p style="text-align: center;">CJ_X401_004</p>

Note: This section is for reference only. Actual unit appearance may vary.

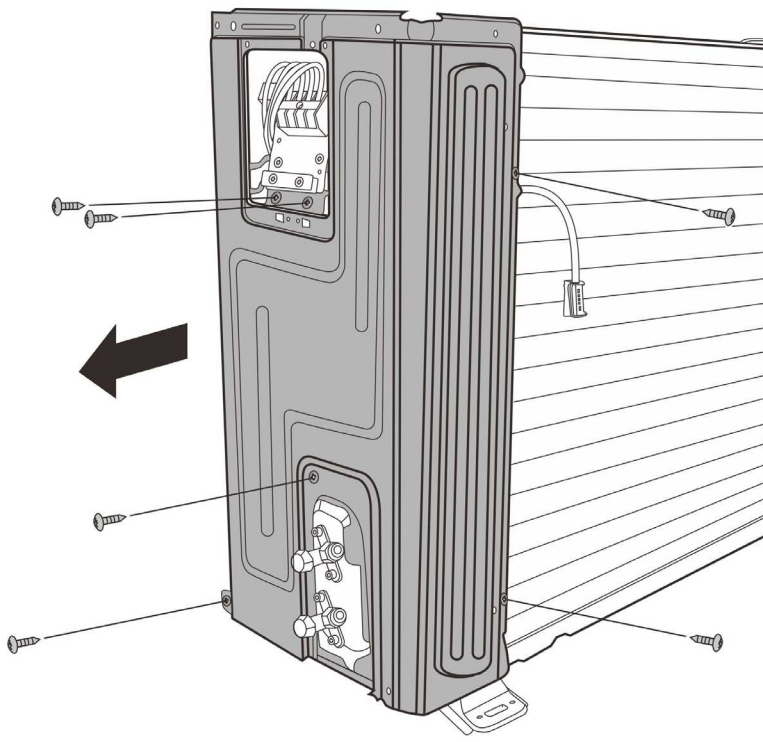
Procedure	Illustration
<p>6) Remove the screws of the right panel and then remove the right panel (6 screws) (see CJ_X401_005).</p>	 <p>CJ_X401_005</p>

Note: This section is for reference only. Actual unit appearance may vary.

6. E30/590

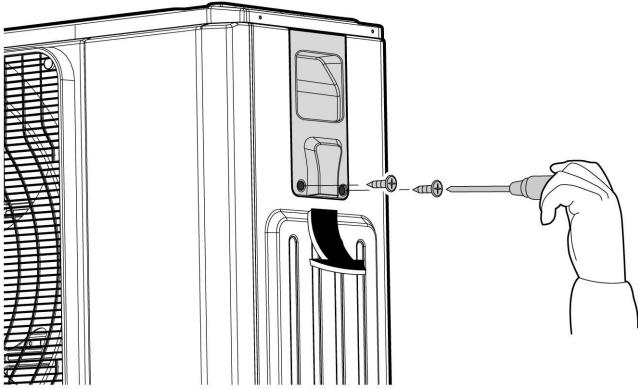
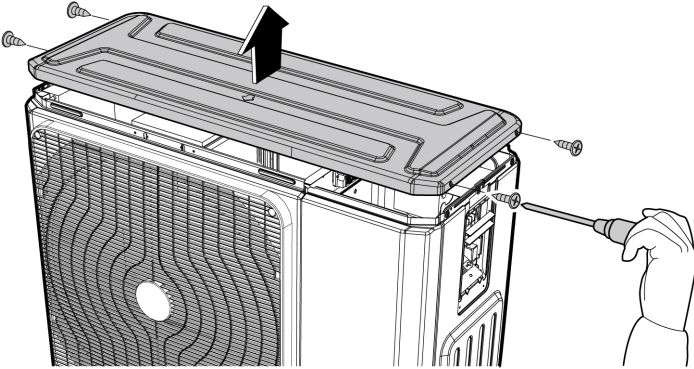
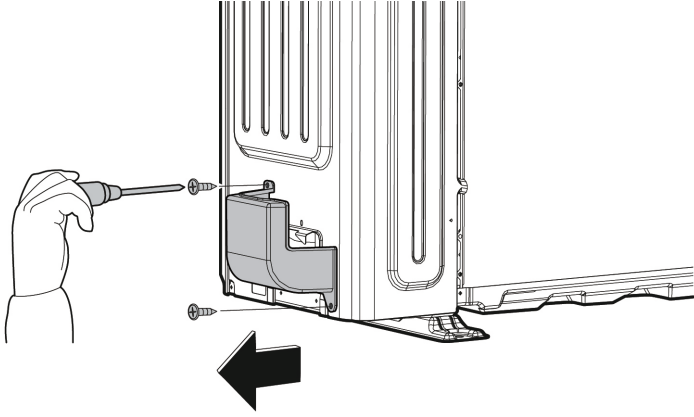
Procedure	Illustration
<p>1) Turn off the air conditioner and the power breaker.</p> <p>2) Remove the screws of the big handle and then remove the big handle (2 screws) (see CJ_E30_001).</p>	 <p>CJ_E30_001</p>
<p>3) Remove the screws of the top cover and then remove the top cover (4 screws). Two of the screws is located underneath the big handle (see CJ_E30_002).</p>	 <p>CJ_E30_002</p>
<p>4) Remove the screws of water collecting cover and then remove the water collecting cover (2 screw) (see CJ_E30_003).</p>	 <p>CJ_E30_003</p>

Note: This section is for reference only. Actual unit appearance may vary.

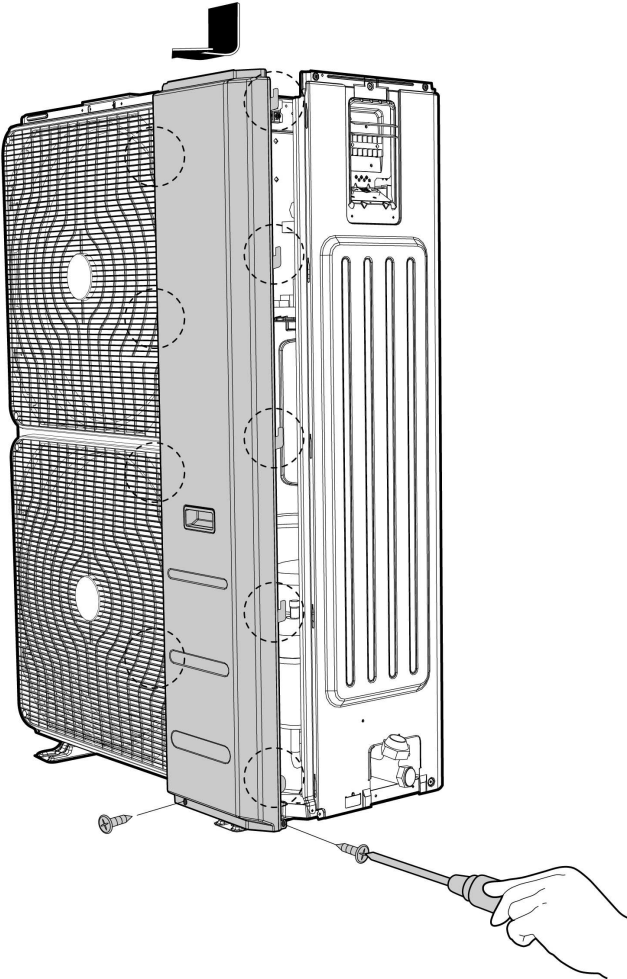
Procedure	Illustration
<p>5) Remove the screws of the front right panel and then remove the front right panel (2 screws) (see CJ_E30_004).</p>	 <p>CJ_E30_004</p>

Note: This section is for reference only. Actual unit appearance may vary.

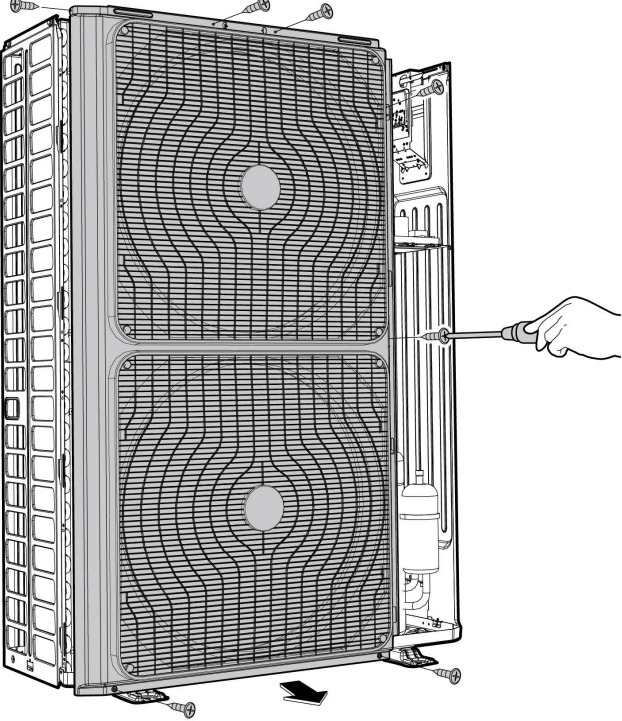
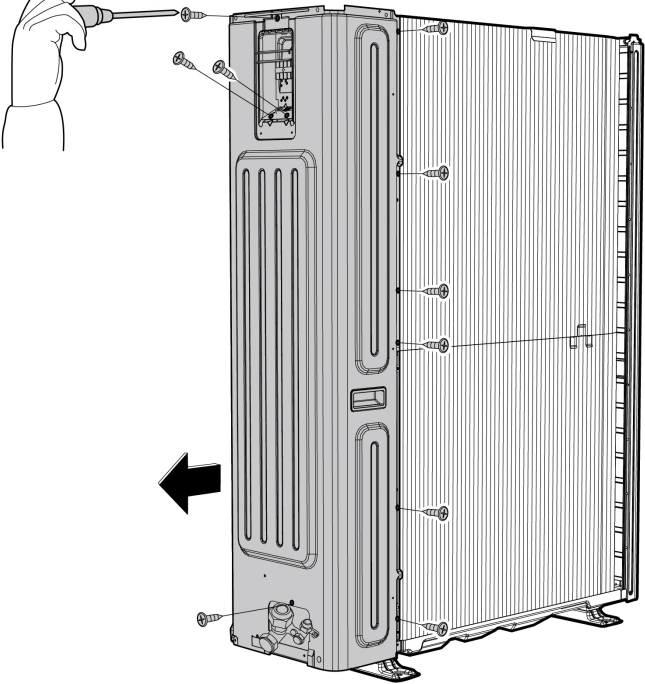
Procedure	Illustration
<p>1) Remove the screws of the front panel and then remove the front panel (7 screws) (see CJ_E30_005).</p>	 <p style="text-align: center;">CJ_E30_005</p>
<p>2) Remove the screws of the right panel and then remove the right panel (10 screws) (see CJ_E30_006).</p>	 <p style="text-align: center;">CJ_E30_006</p>

Note: This section is for reference only. Actual unit appearance may vary.

2.2 Electrical parts

⚠ WARNING: Antistatic gloves must be worn when you disassemble the electronic box.

Note: Remove the air outlet grille(refer to 3.1 Panel Plate) before disassembling electrical parts.

i) PCB for ON-OFF Models

1. PCB board 1

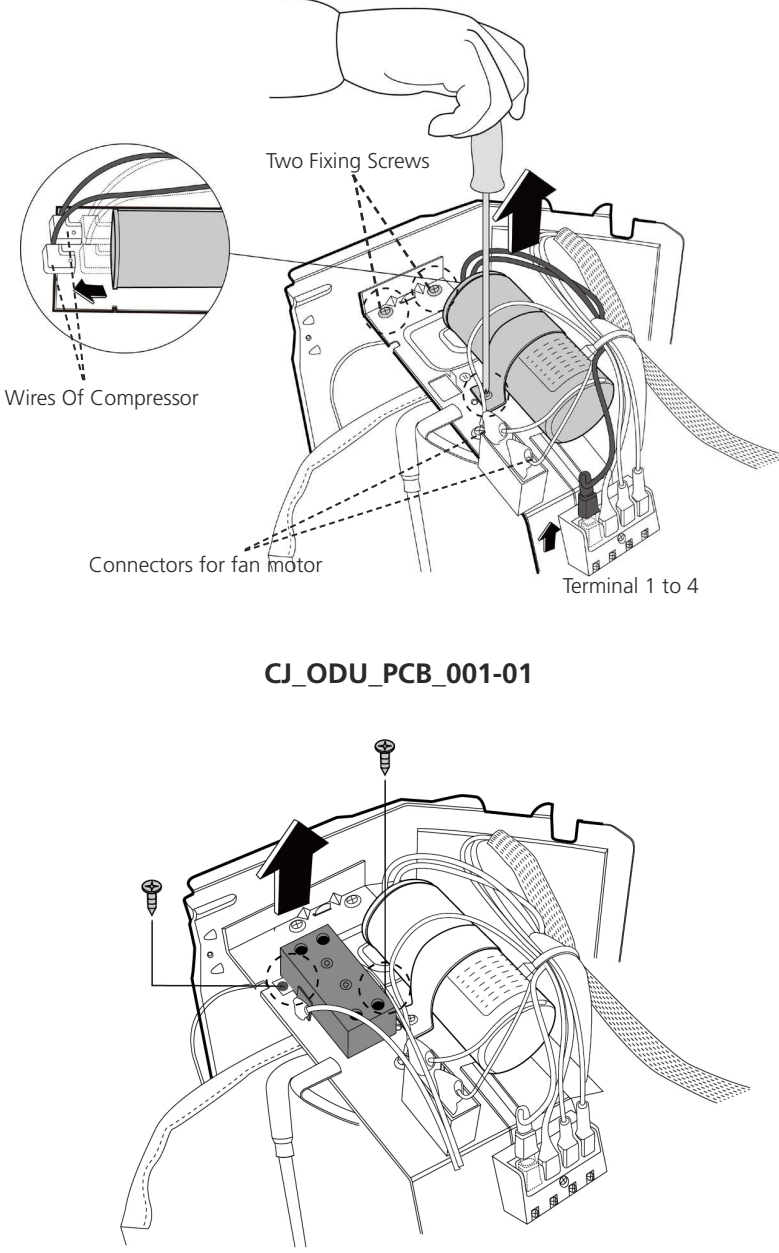
Procedure	Illustration
<ol style="list-style-type: none">1) Remove the two screws fixed the electronic control board (see CJ_ODU_PCB_001).2) Disconnect the connectors for fan motor. (Blue wire, yellow wire, red wire, brown wire and black wire. The blue wire and red wire are on the capacitor. The black wire connects with terminal 4.) (see CJ_ODU_PCB_001)3) Disconnect the wires connected to the compressor. (Black wire connects with terminal 1, blue wire and red wire connect with the compressor capacitor) (see CJ_ODU_PCB_001)4) Disconnect the wires connected to 4-way valve.(Blue wires on terminal 2&3) (see CJ_ODU_PCB_001)5) Remove the fixing screw of the compressor capacitor, then pull it out (see CJ_ODU_PCB_001)6) Remove the electrical parts (see CJ_ODU_PCB_001)7) For models with AC conductor, remove 2 screws of it showed in the figure.	 <p style="text-align: center;">CJ_ODU_PCB_001-01</p> <p style="text-align: center;">CJ_ODU_PCB_001-02</p>

Note: This section is for reference only. Actual unit appearance may vary.

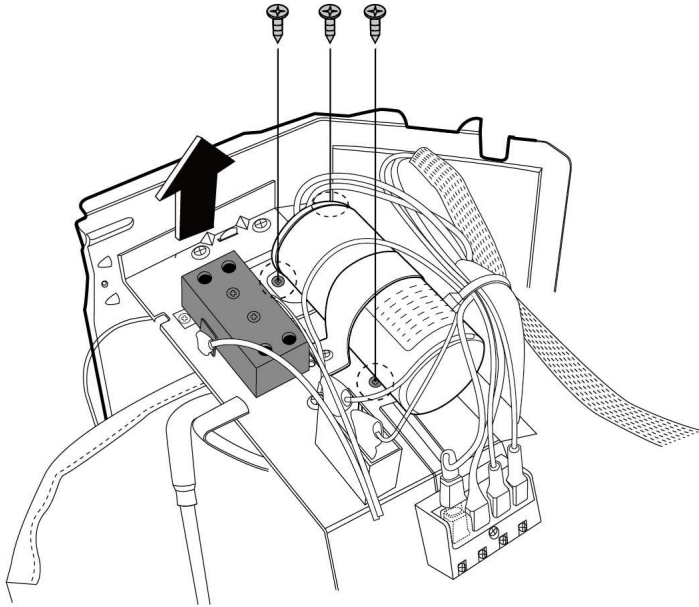
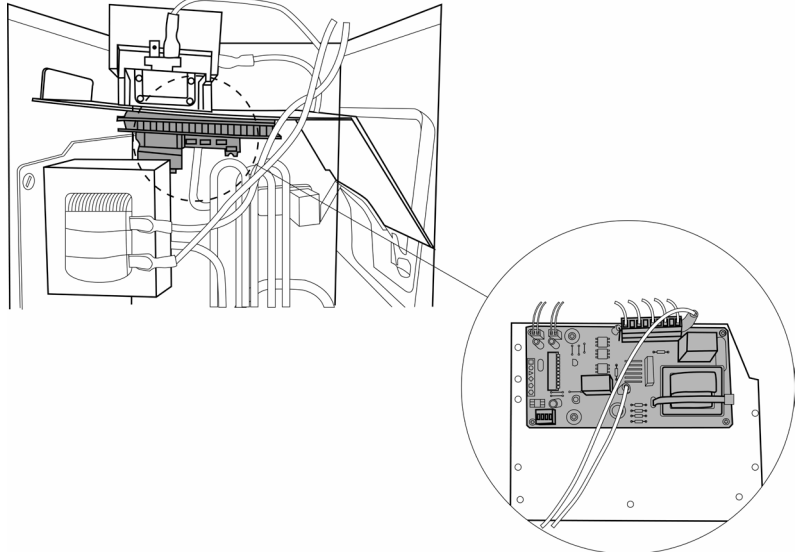
Procedure	Illustration
<p>8) For models with subzero refrigeration control board, remove 3 screws of it showed in the figure.</p>	 <p style="text-align: center;">CJ_ODU_PCB_001-03</p>
<p>9) The subzero refrigeration control board is in the back of the metal sheet.</p>	 <p style="text-align: center;">CJ_ODU_PCB_001-04</p>

Note: This section is for reference only. Actual unit appearance may vary.

2. PCB board 2

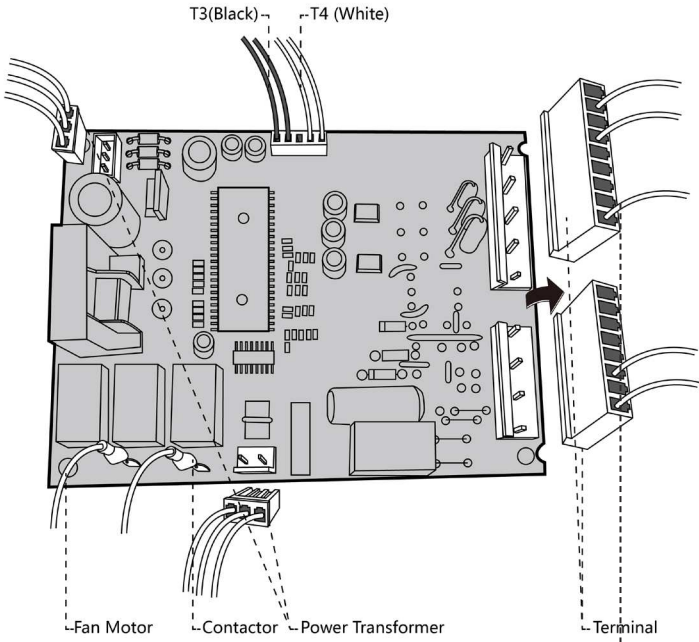
Procedure	Illustration
<ol style="list-style-type: none">1) Disconnect the power transformer (see CJ_ODU_010)2) Disconnect the wires connected to terminals. (see CJ_ODU_010)3) Disconnect the wires connected to contactor. (see CJ_ODU_010)4) Disconnect the wires connected to T3/T4 sensor. (see CJ_ODU_010)	 <p>The diagram illustrates the PCB board 2 with various components and their connections. Labels include:</p> <ul style="list-style-type: none">T3(Black)T4 (White)Fan MotorContactorPower TransformerTerminal <p>The diagram shows a top-down view of the PCB board with various components and their connections. Dashed lines indicate the connections between the components and the board. An arrow points to the terminal block on the right side of the board.</p> <p style="text-align: center;">CJ_ODU_PCB_002-1</p>

Note: This section is for reference only. Actual unit appearance may vary.

3. PCB board 3

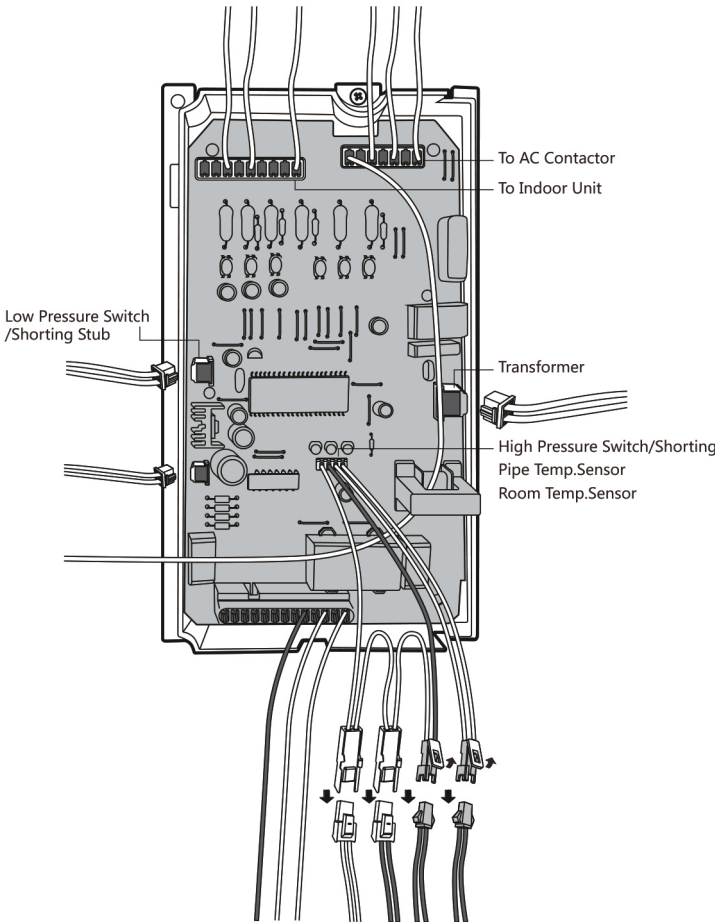
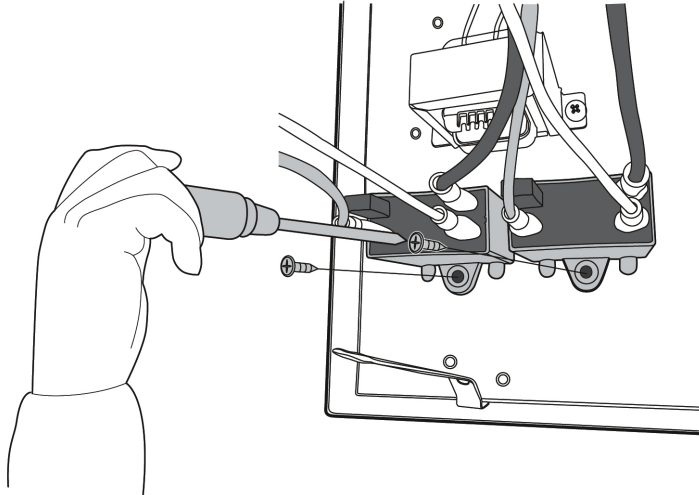
Procedure	Illustration
<ol style="list-style-type: none"> 1) Disconnect the wires connected to the transformer. (see CJ_ODU_PCB_003-1) 2) Disconnect the wires connected to high/low pressure switch. (see CJ_ODU_PCB_003-1) 3) Disconnect the wires connected to indoor unit. (see CJ_ODU_PCB_003-1) 4) Disconnect the wires connected to AC contactor. (see CJ_ODU_PCB_003-1) 	 <p style="text-align: center;">CJ_ODU_PCB_003-1</p>
<ol style="list-style-type: none"> 5) Remove the screws of the capacitor and then remove it (1 screw for each capacitor). (see CJ_ODU_PCB_003-2) 	 <p style="text-align: center;">CJ_ODU_PCB_003-2</p>

Note: This section is for reference only. Actual unit appearance may vary.

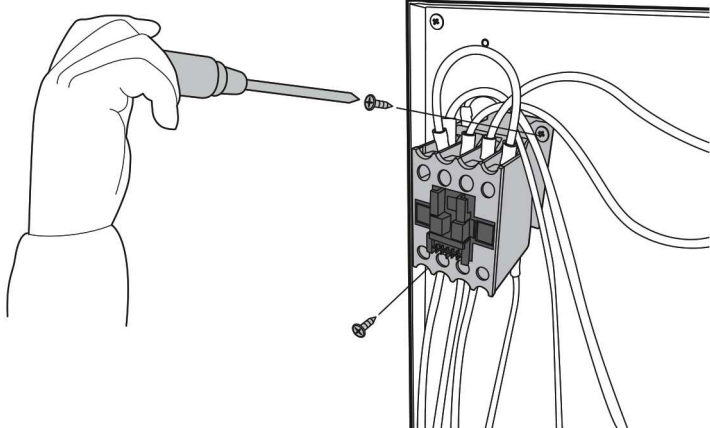
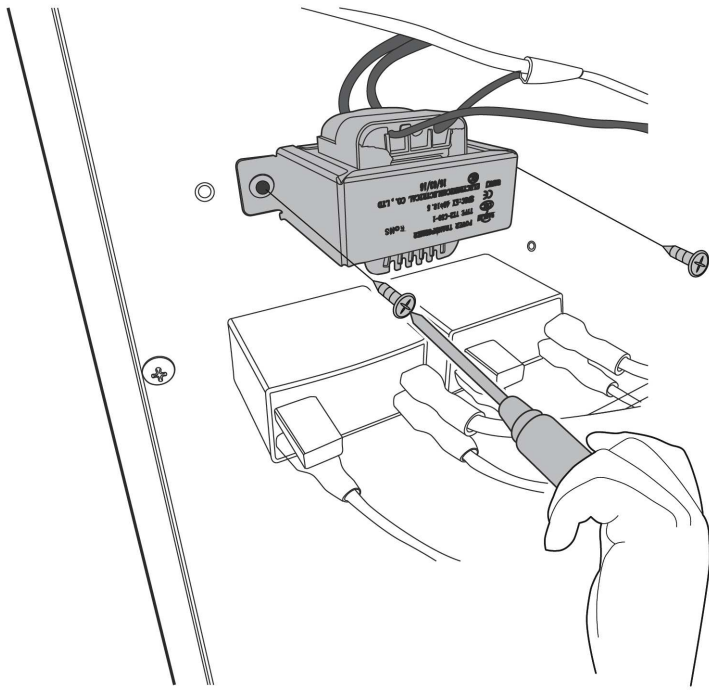
Procedure	Illustration
<p>6) Remove the 1 screw of the AC contactor and then remove it. (see CJ_ODU_PCB_003-3)</p>	 <p style="text-align: center;">CJ_ODU_PCB_003-3</p>
<p>7) Remove 2 screws of the transformer and then remove it. (see CJ_ODU_PCB_003-4)</p>	 <p style="text-align: center;">CJ_ODU_PCB_003-4</p>

Note: This section is for reference only. Actual unit appearance may vary.

ii) PCB for Inverter Models

4. PCB board 4

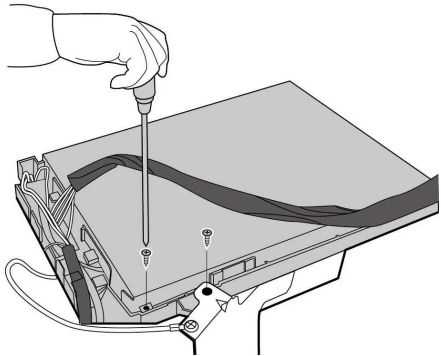
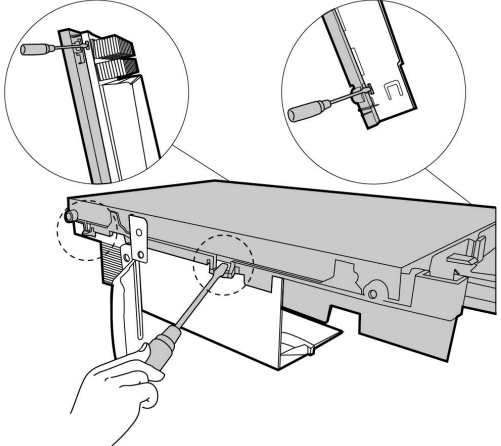
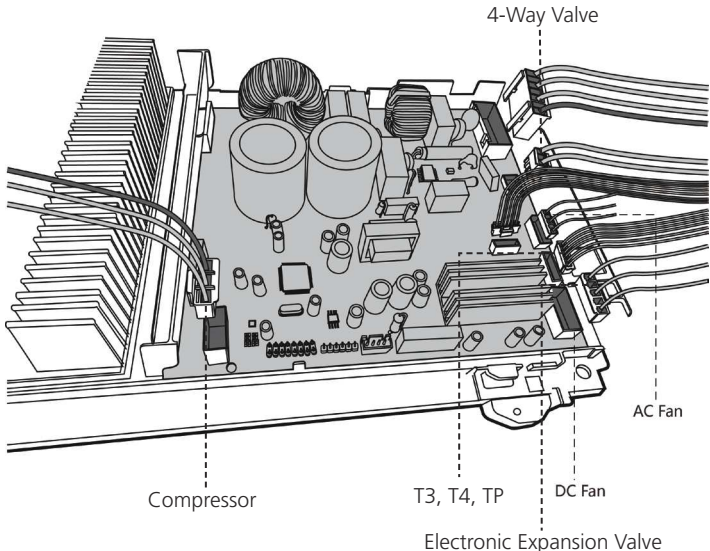
Procedure	Illustration
<p>1) Remove the screws of the top cover. (2 screws) (see CJ_ODU_PCB_004-1).</p>	 <p style="text-align: center;">CJ_ODU_PCB_004-1</p>
<p>2) Unfix the hooks and then open the electronic control box cover (4 hooks) (see CJ_ODU_PCB_004-2).</p>	 <p style="text-align: center;">CJ_ODU_PCB_004-2</p>
<p>3) Disconnect the connector for fan motor from the electronic control board (see CJ_ODU_PCB_004-3).</p> <p>4) Remove the connector for the compressor (see CJ_ODU_PCB_004-3).</p> <p>5) Pull out the two blue wires connected with the four way valve (CJ_ODU_PCB_004-3).</p> <p>6) Pull out connectors of the condenser coil temp. sensor(T3), outdoor ambient temp. sensor(T4) and discharge temp. sensor(TP) (CJ_ODU_PCB_004-3).</p> <p>7) Disconnect the electronic expansion valve wire (CJ_ODU_PCB_004-3).</p> <p>8) Then remove the electronic control board.</p>	 <p style="text-align: center;">CJ_ODU_PCB_004-3</p>

Note: This section is for reference only. Actual unit appearance may vary.

5. PCB board 5

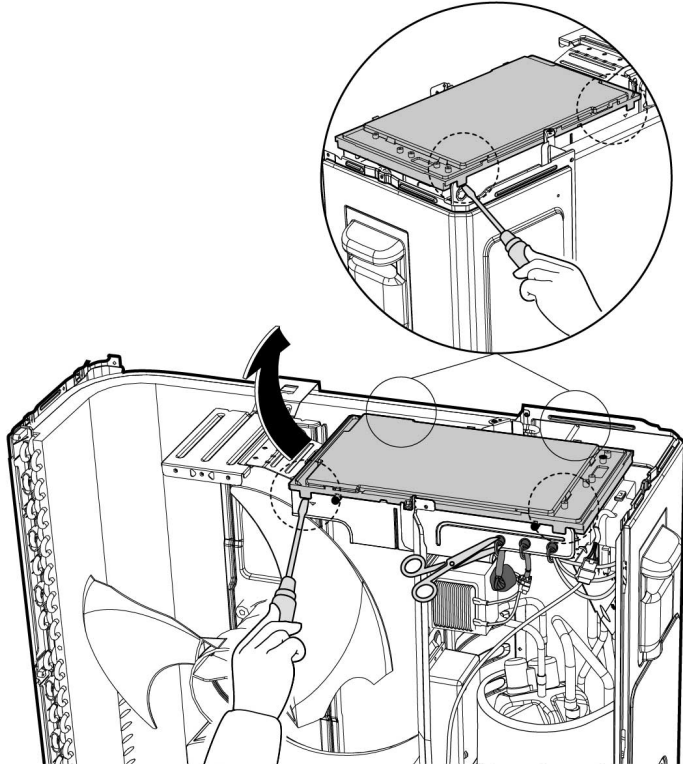
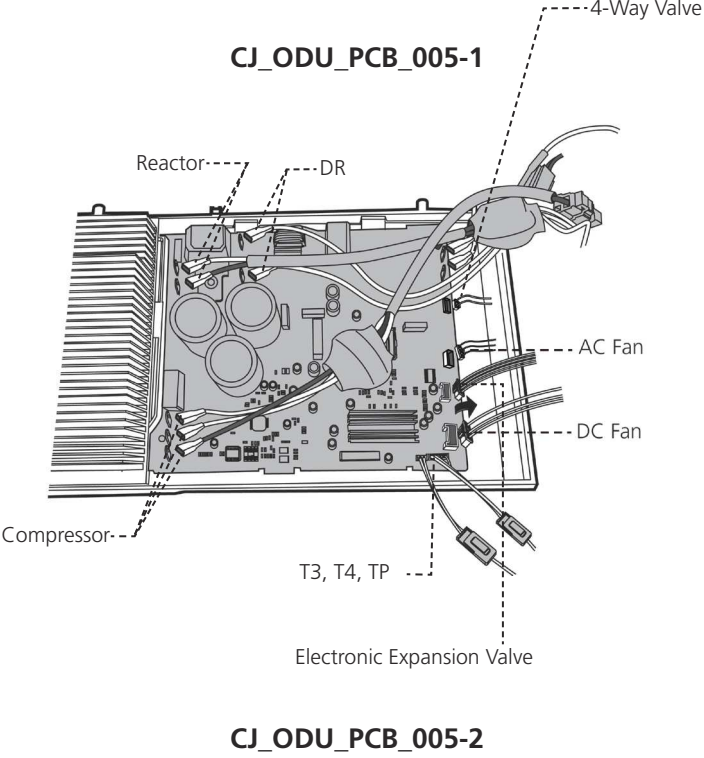
Procedure	Illustration
<p>1) Unfix the hooks and then open the electronic control box cover (4 hooks) (see CJ_ODU_PCB_005-1).</p>	
<p>2) Disconnect the connector for fan motor from the electronic control board (see CJ_ODU_PCB_005-2).</p> <p>3) Remove the connector for the compressor (see CJ_ODU_PCB_005-2).</p> <p>4) Pull out the two blue wires connected with the four way valve (see CJ_ODU_PCB_005-2).</p> <p>5) Pull out connectors of the condenser coil temp. sensor(T3), outdoor ambient temp. sensor(T4) and discharge temp. sensor(TP) (see CJ_ODU_PCB_005-2).</p> <p>6) Disconnect the electronic expansion valve wire (see Fig CJ_ODU_PCB_005-2).</p> <p>7) Then remove the electronic control board.</p>	 <p style="text-align: center;">CJ_ODU_PCB_005-1</p> <p style="text-align: center;">CJ_ODU_PCB_005-2</p>

Note: This section is for reference only. Actual unit appearance may vary.

6. PCB board 6

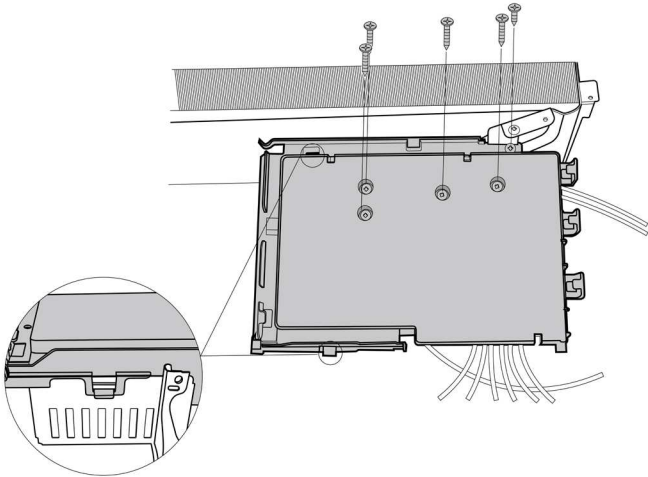
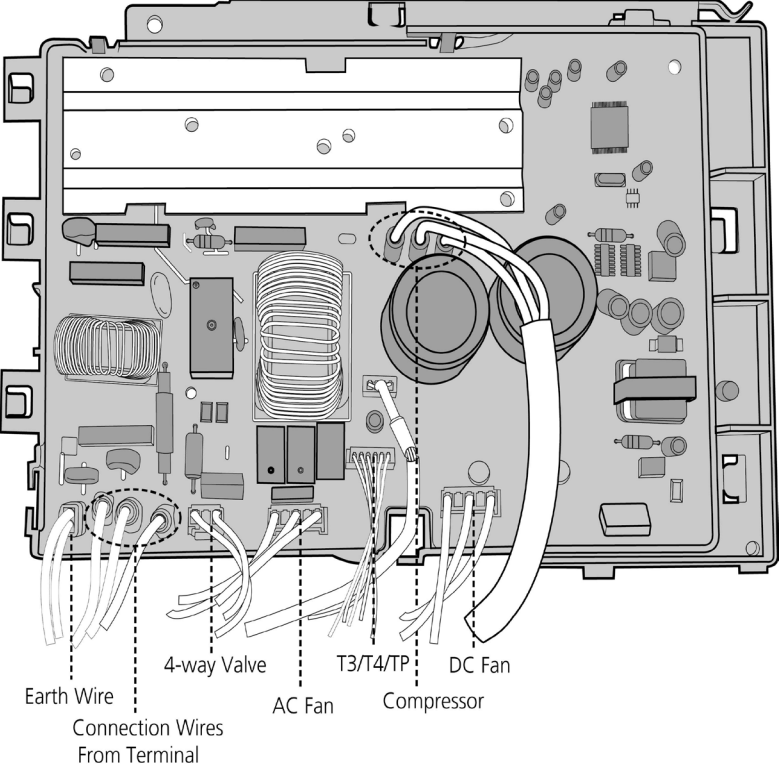
Procedure	Illustration
<p>1) Remove the screws and unfix the hooks, then open the electronic control box cover (5 screws and 2 hooks)(see CJ_ODU_PCB_006-1).</p>	 <p style="text-align: center;">CJ_ODU_PCB_006-1</p>
<p>2) Disconnect the connector for fan motor from the electronic control board (see CJ_ODU_PCB_006-2).</p> <p>3) Remove the connector for the compressor (see CJ_ODU_PCB_006-2).</p> <p>4) Pull out the two blue wires connected with the four way valve (see CJ_ODU_PCB_006-2).</p> <p>5) Pull out connectors of the condenser coil temp. sensor(T3),outdoor ambient temp. sensor(T4) and discharge temp. sensor(TP) (see CJ_ODU_PCB_006-2).</p> <p>6) Disconnect the electronic expansion valve wire (see Fig CJ_ODU_PCB_006-2).</p> <p>7) Remove the connector for the DR and reactor (see Fig CJ_ODU_PCB_006-2).</p> <p>8) Then remove the electronic control board.</p>	 <p style="text-align: center;">CJ_ODU_PCB_006-2</p>

Note: This section is for reference only. Actual unit appearance may vary.

7. PCB board 7

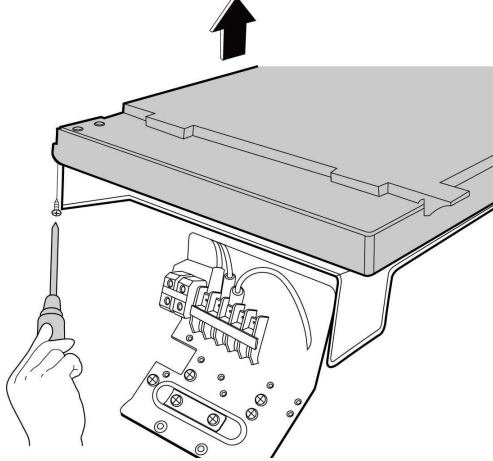
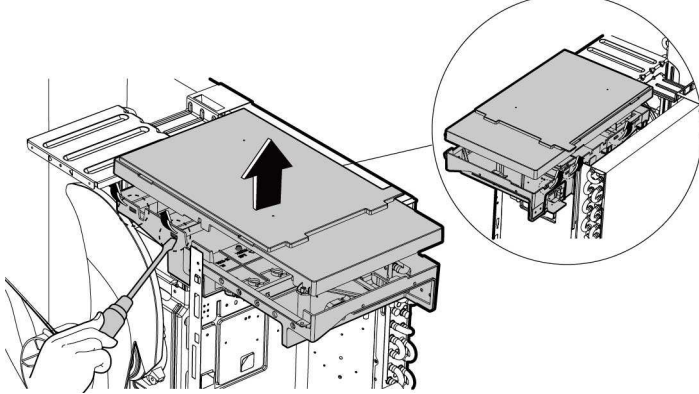
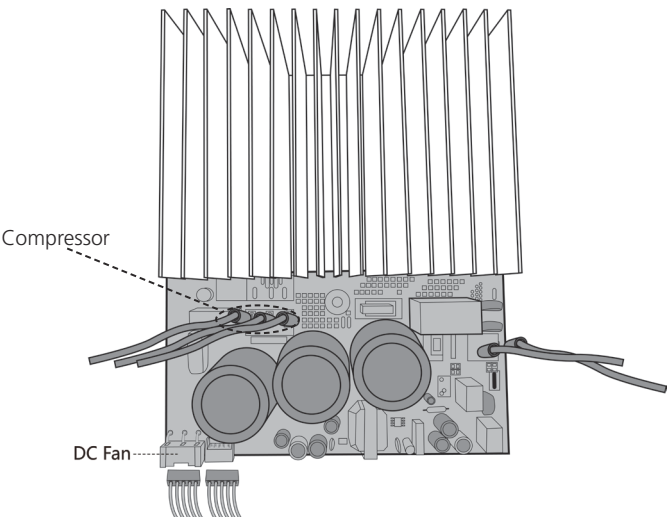
Procedure	Illustration
1) Remove the screws of the top cover. (1 screws) (see CJ_ODU_PCB_007-1).	 <p style="text-align: center;">CJ_ODU_PCB_007-1</p>
2) Unfix the hooks and then open the electronic control box cover (5 hooks) (see CJ_ODU_PCB_007-2).	 <p style="text-align: center;">CJ_ODU_PCB_007-2</p>
3) Disconnect the connector for fan motor from the IPM board (see CJ_ODU_PCB_007-3). 4) Remove the connector for the compressor (see CJ_ODU_PCB_007-3).	 <p style="text-align: center;">CJ_ODU_PCB_007-3</p>

Note: This section is for reference only. Actual unit appearance may vary.

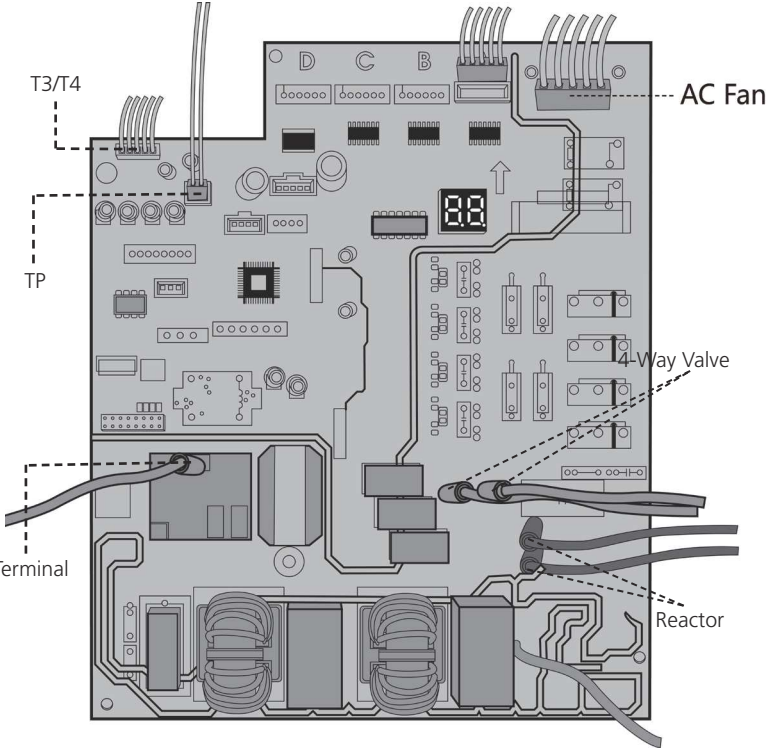
Procedure	Illustration
<p>5) Pull out the wire connected with the terminal. (see CJ_ODU_PCB_007-4).</p> <p>6) Pull out connectors of the condenser coil temp. sensor(T3),outdoor ambient temp. sensor(T4) and discharge temp. sensor(TP) (see CJ_ODU_PCB_007-4).</p> <p>7) Disconnect the electronic expansion valve wire (see Fig CJ_ODU_PCB_007-4).</p> <p>8) Remove the connector for 4-way valve. (see Fig CJ_ODU_PCB_007-4).</p> <p>9) Remove the connector for the reactor (see Fig CJ_ODU_PCB_007-4).</p> <p>10)Then remove the electronic control box (see Fig CJ_ODU_PCB_007-4).</p>	 <p style="text-align: center;">CJ_ODU_PCB_007-4</p>

Note: This section is for reference only. Actual unit appearance may vary.

8. PCB board 8

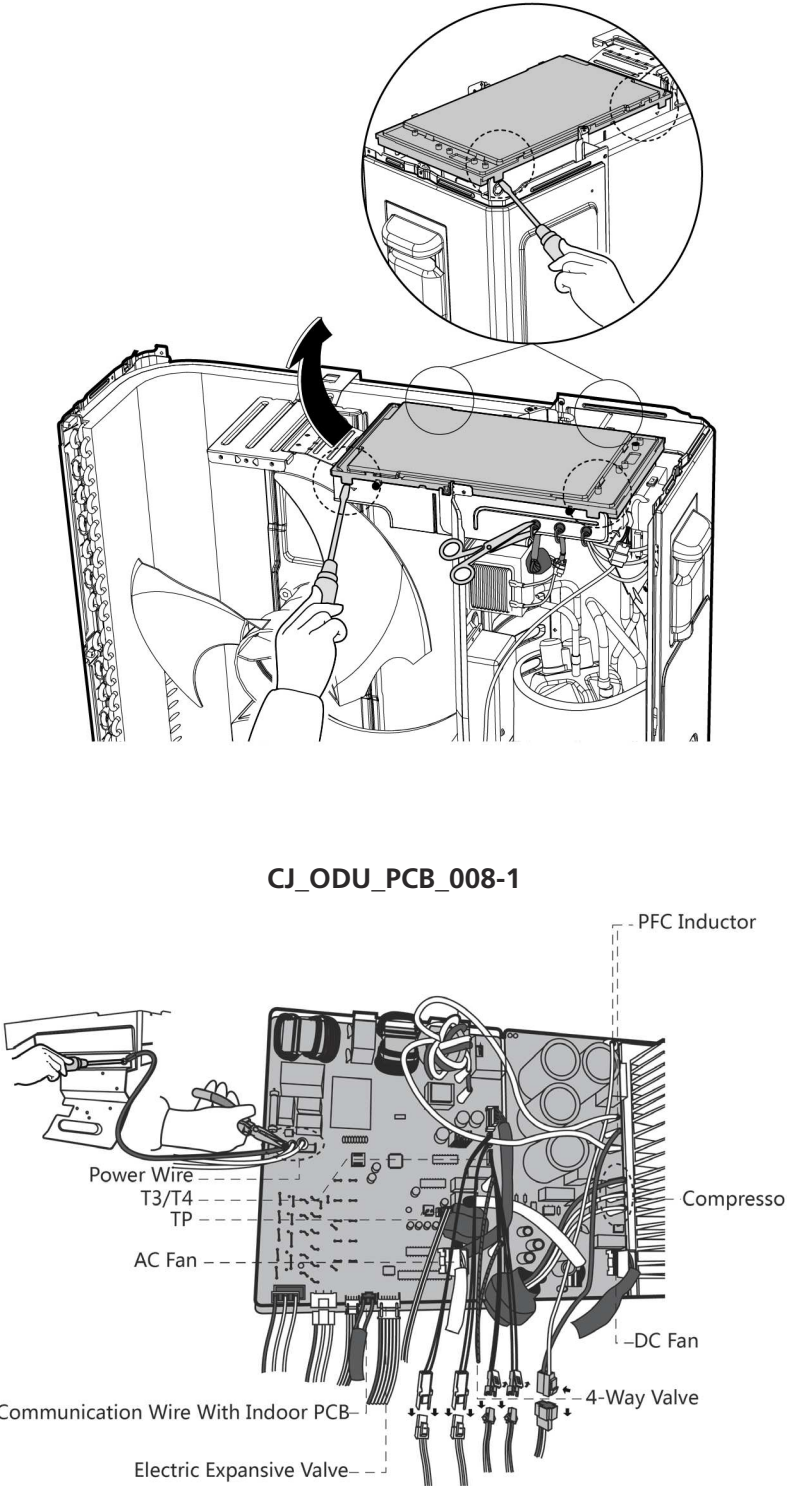
Procedure	Illustration
<ol style="list-style-type: none"> 1) Unfix the hooks and then open the electronic control box cover (4 hooks) (see CJ_ODU_PCB_008-1). 2) Disconnect the connector for outdoor DC fan from the electronic control board (see CJ_ODU_PCB_008-2). 3) Remove the connector for the compressor (see CJ_ODU_PCB_008-2). 4) Pull out the two blue wires connected with the four way valve (see CJ_ODU_PCB_008-2). 5) Pull out connectors of the condenser coil temp. sensor(T3), outdoor ambient temp. sensor(T4) and discharge temp. sensor(TP) (see CJ_ODU_PCB_008-2). 6) Disconnect the electronic expansion valve wire (see Fig CJ_ODU_PCB_008-2). 7) Disconnect the communication wire indoor PCB (see Fig CJ_ODU_PCB_008-2). 8) Disconnect the PFC inductor (see Fig CJ_ODU_PCB_008-2). 9) Then remove the electronic control box (see CJ_ODU_PCB_008-2). 	 <p style="text-align: center;">CJ_ODU_PCB_008-1</p> <p style="text-align: center;">CJ_ODU_PCB_008-2</p> <p>The illustration is divided into two parts. The top part, labeled 'CJ_ODU_PCB_008-1', shows a hand using a screwdriver to remove four hooks from the electronic control box cover. An inset circle provides a magnified view of the hook removal process. The bottom part, labeled 'CJ_ODU_PCB_008-2', shows the internal PCB board with various components and wires labeled. The labels include: Power Wire, T3/T4, TP, AC Fan, PFC Inductor, Compressor, DC Fan, 4-Way Valve, Communication Wire With Indoor PCB, and Electric Expansive Valve.</p>

Note: This section is for reference only. Actual unit appearance may vary.

9. PCB board 9

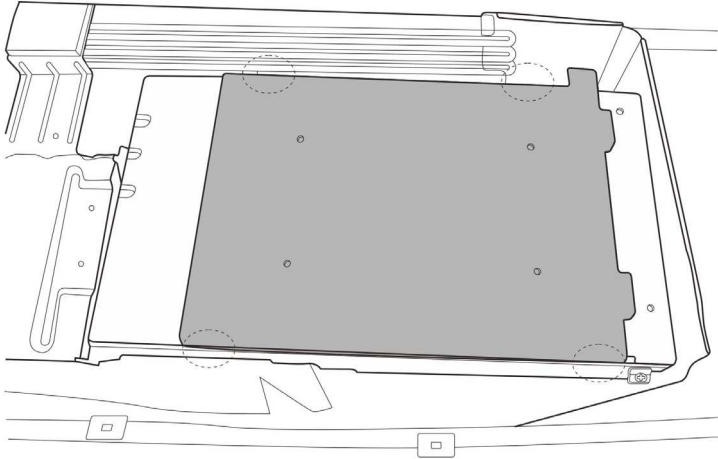
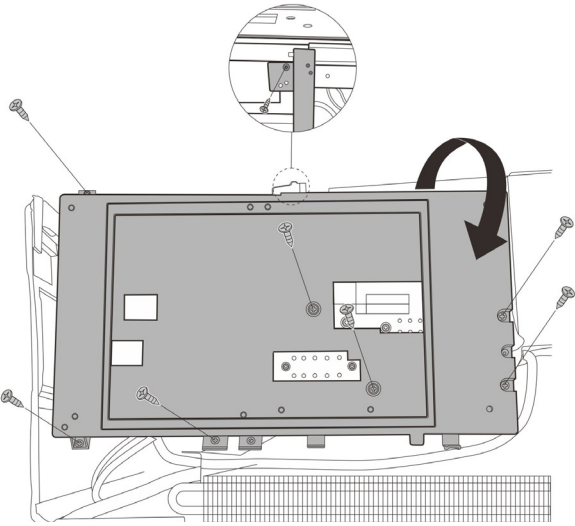
Procedure	Illustration
<p>1) Unfix the hooks and then open the electronic control box cover (4 hooks) (see CJ_ODU_PCB_009-1).</p>	 <p>The diagram shows a top-down view of the electronic control box cover being detached from the PCB board. Four dashed circles indicate the locations of the hooks that hold the cover in place. The cover is shown being lifted away from the board.</p> <p style="text-align: center;">CJ_ODU_PCB_009-1</p>
<p>2) Remove 8 screws on the electronic control board and then turn over the electronic control board (see CJ_ODU_PCB_009-2).</p>	 <p>The diagram shows the electronic control board with eight screws being removed. A circular inset provides a magnified view of one of the screws being loosened. A large black arrow indicates that the board should be turned over. The board is shown with various components and connectors.</p> <p style="text-align: center;">CJ_ODU_PCB_009-2</p>

Note: This section is for reference only. Actual unit appearance may vary.

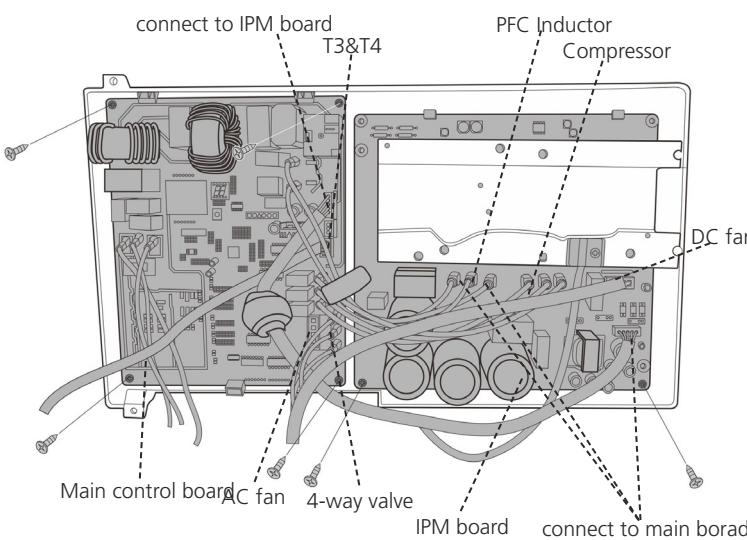
Procedure	Illustration
<p>3) Pull out the two blue wires connected with the four way valve. (see CJ_ODU_PCB_009-3)(for heat pump models)</p> <p>4) Pull out connectors of the condenser coil temp. sensor(T3),outdoor ambient temp. sensor(T4) and discharge temp. sensor(TP). (see CJ_ODU_PCB_009-3)</p> <p>5) Disconnect the electronic expansion valve wire. (see Fig CJ_ODU_PCB_009-3)(for some models)</p> <p>6) Remove four screws and unfix the 3 hooks and then remove the main control board. (see CJ_ODU_PCB_009-3)</p> <p>7) Disconnect the connector for outdoor DC fan from the IPM board. (see CJ_ODU_PCB_009-3)(for some models)</p> <p>8) Remove the connector for the compressor. (see CJ_ODU_PCB_009-3)</p> <p>9) Remove the connector for the PFC Inductor. (see CJ_ODU_PCB_009-3)</p> <p>10)Pull out 3 connectors between IPM board and main control board.(see CJ_ODU_PCB_009-3)</p> <p>11)Remove two screws and unfix the 4 hooks and then remove the IPM board. (see CJ_ODU_PCB_009-3)</p>	 <p style="text-align: center;">CJ_ODU_PCB_009-3</p>

Note: This section is for reference only. Actual unit appearance may vary.

10. PCB board 10

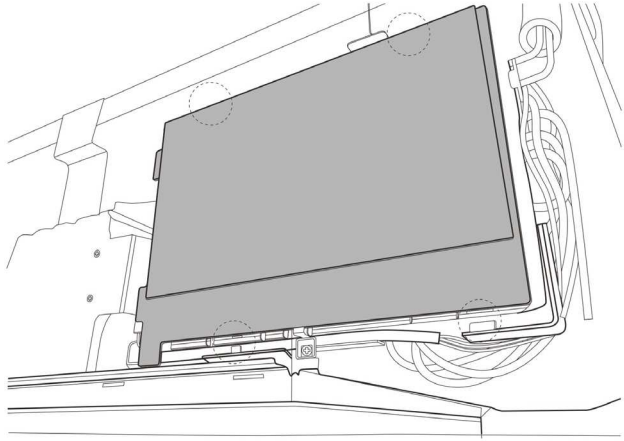
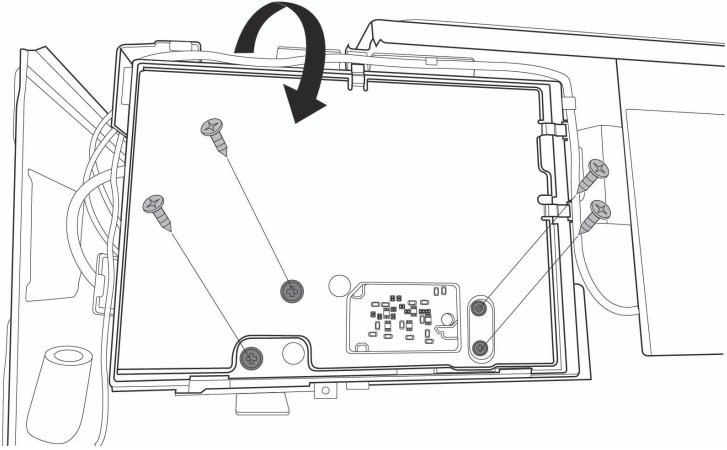
Procedure	Illustration
<p>1) Unfix the hooks and then open the electronic control box cover (4 hooks) (see CJ_ODU_PCB_010-1).</p>	 <p>The diagram shows a perspective view of the electronic control box cover being detached from the PCB board. Four dashed circles indicate the locations of the hooks that hold the cover in place. The cover is shown being lifted away from the board.</p> <p data-bbox="879 958 1134 992">CJ_ODU_PCB_010-1</p>
<p>2) Remove 4 screws on the electronic control board and then turn over the electronic control board (see CJ_ODU_PCB_010-2).</p>	 <p>The diagram shows the electronic control board with four screws being removed. A curved arrow indicates that the board should be turned over. The board is shown in a perspective view, with the screws being removed from the top surface.</p> <p data-bbox="879 1644 1134 1677">CJ_ODU_PCB_010-2</p>

Note: This section is for reference only. Actual unit appearance may vary.

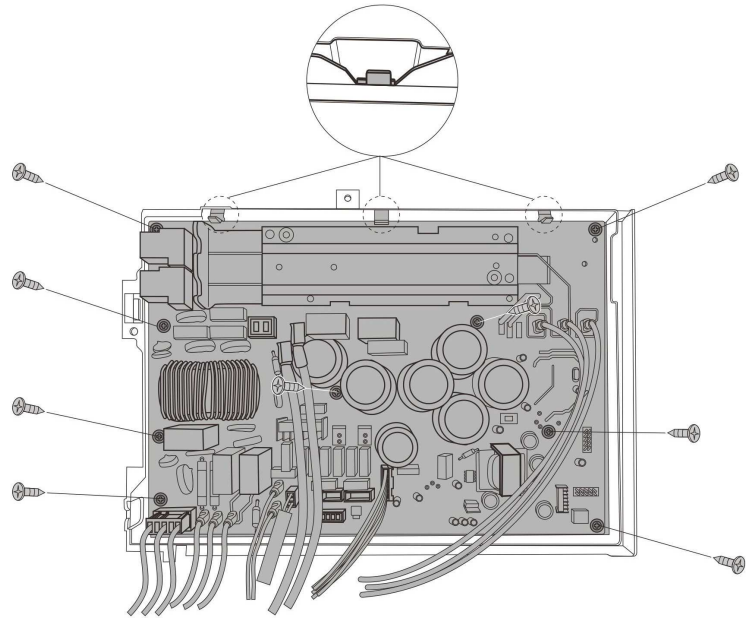
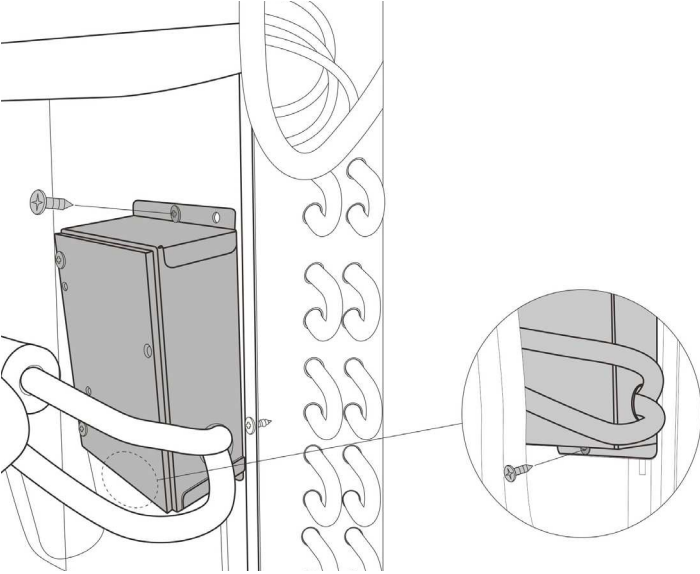
Procedure	Illustration
<p>3) Pull out the connectors (see CJ_ODU_PCB_010-3).</p> <p>4) Remove the 9 screws and unfix the 3 hooks and then remove the electronic control board(see CJ_ODU_PCB_010-3).</p>	 <p style="text-align: center;">CJ_ODU_PCB_010-3</p>
<p>5) Remove two screws and then remove the electronic control box subassembly on partition board assembly. (see CJ_ODU_PCB_010-4).</p>	 <p style="text-align: center;">CJ_ODU_PCB_010-4</p>

Note: This section is for reference only. Actual unit appearance may vary.

10. PCB board 10

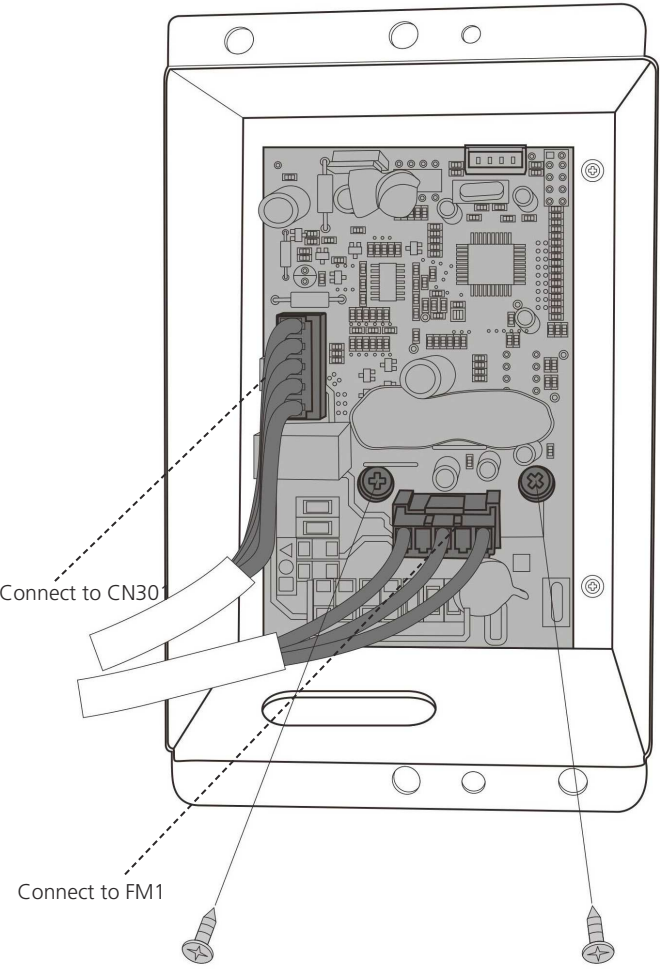
Procedure	Illustration
<p>6) Remove two screws and two connectors and then remove the inverter control board (see CJ_ODU_PCB_010-5).</p>	 <p>The diagram shows a PCB board (CJ_ODU_PCB_010-5) mounted inside a rectangular enclosure. Two screws are shown being inserted into the bottom of the enclosure to secure the board. Two cables are shown being connected to the board: one to a connector labeled 'CN30' and another to a terminal labeled 'FM1'. Dashed lines indicate the connection points and the location of the screws.</p> <p>Connect to CN30</p> <p>Connect to FM1</p> <p>CJ_ODU_PCB_010-5</p>

Note: This section is for reference only. Actual unit appearance may vary.

11. PCB board 11

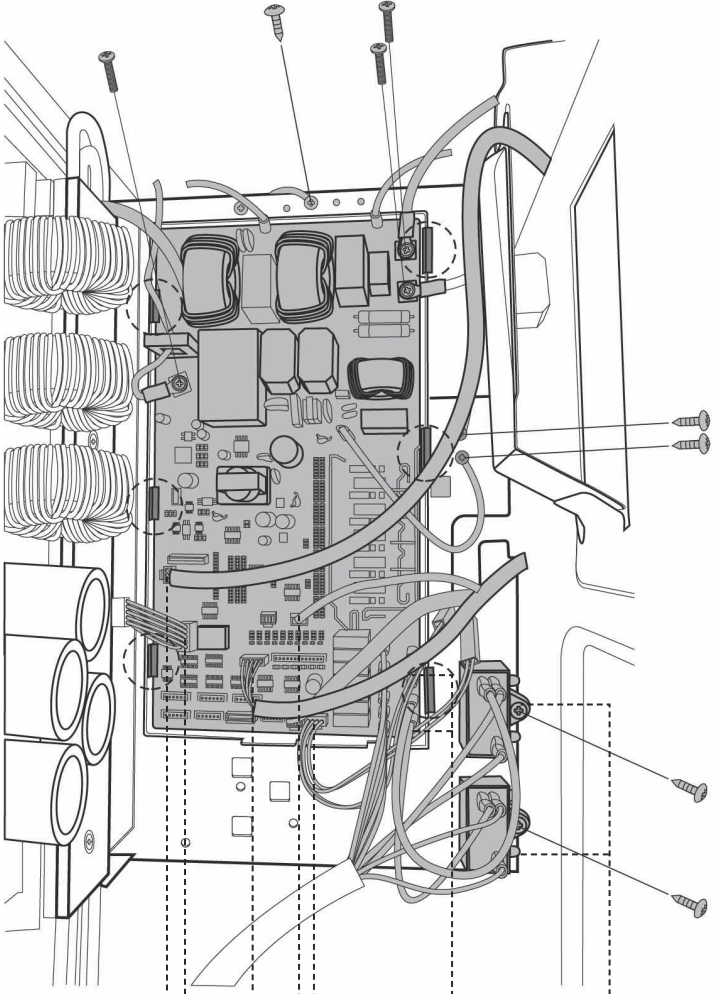
Procedure	Illustration
<ol style="list-style-type: none"> 1) Remove 2 screws to disconnect the power supply wires. (see CJ_ODU_PCB_011-1) 2) Remove 3 screws to disconnect ground wires. (see CJ_ODU_PCB_011-1) 3) Disconnect the wires connected to main control board. (see CJ_ODU_PCB_011-1) 4) Disconnect the wires between main control board and IPM module board. (see CJ_ODU_PCB_011-1) 5) Remove the 4 screws and unfix the 6 hooks and then remove the main control board. (see CJ_ODU_PCB_011-1) 6) Remove 1 screw to remove the fan motor capacitor (1 screw for each capacitor). (see CJ_ODU_PCB_004-1). 	 <p style="text-align: center;">CJ_ODU_PCB_011-1</p>

Note: This section is for reference only. Actual unit appearance may vary.

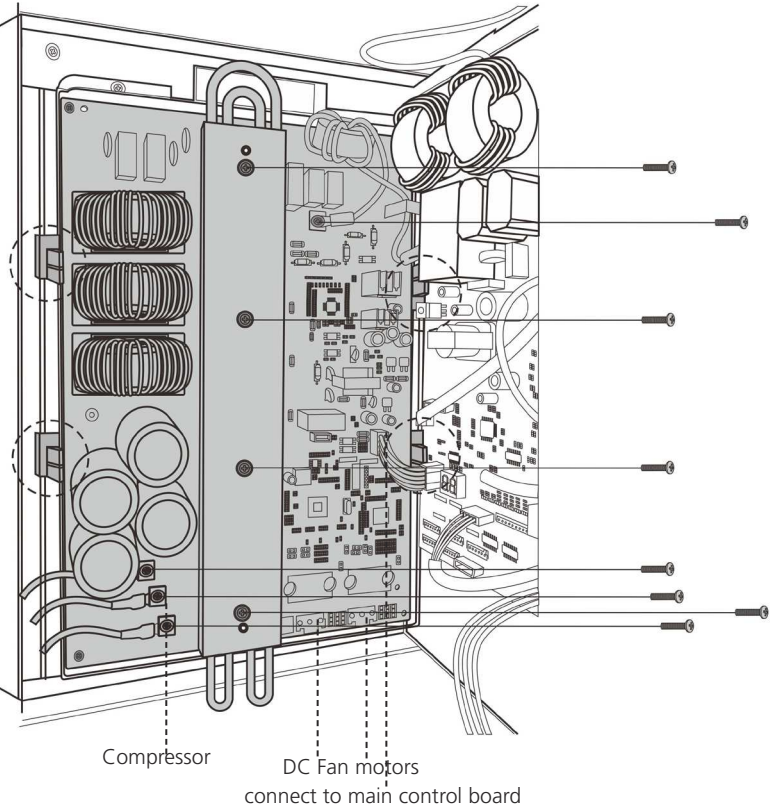
Procedure	Illustration
<ol style="list-style-type: none"> 1) Remove 2 screws to disconnect the power supply wires. (see CJ_ODU_PCB_011-2) 2) Remove 3 screws to disconnect the wires connected to the compressor. (see CJ_ODU_PCB_011-2) 3) Remove 3 screws to remove the radiator.(see CJ_ODU_PCB_011-2) 4) Disconnect the wires between IPM module board and main control board. (see CJ_ODU_PCB_011-2) 5) Remove the 4 screws and unfix the 4 hooks and then remove the IPM modul board.(see CJ_ODU_PCB_011-2) 	 <p style="text-align: center;">CJ_ODU_PCB_011-2</p>

Note: This section is for reference only. Actual unit appearance may vary.

12. PCB board 12

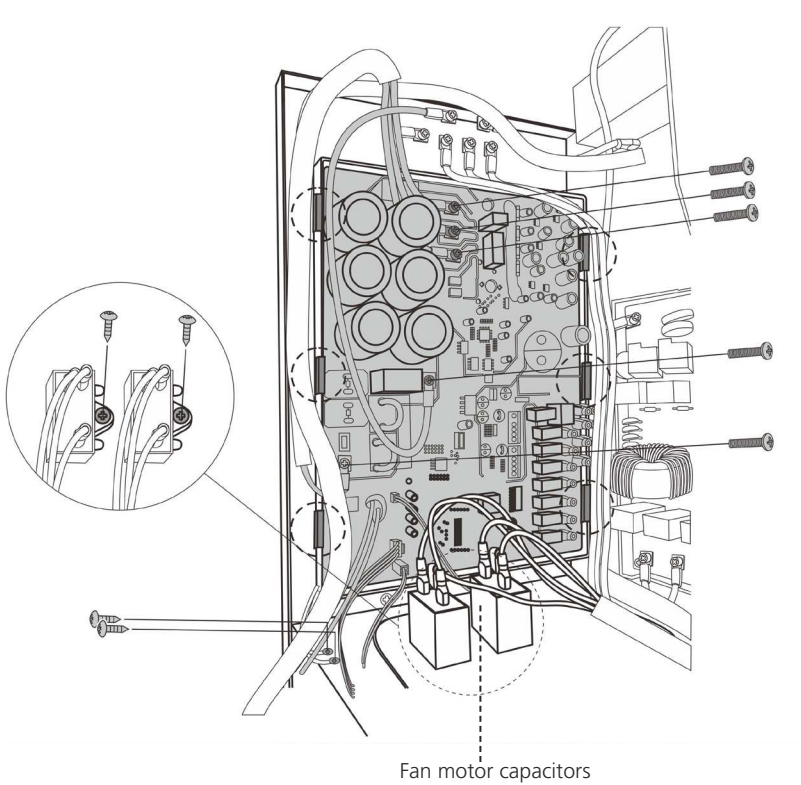
Procedure	Illustration
<ol style="list-style-type: none">1) Remove 3 screws to disconnect the wires connected to the compressor. (see CJ_ODU_PCB_012-1)2) Remove 2 screws to disconnect the power supply wires. (see CJ_ODU_PCB_012-1)3) Disconnect the wires connected to main control board. (see CJ_ODU_PCB_012-1)4) Remove the 4 screws and unfix the 6 hooks and then remove the main control board. (see CJ_ODU_PCB_012-1)5) Remove the screw of the fan capacitor and then remove it (1 screw for each capacitor). (see CJ_ODU_PCB_012-1)	 <p data-bbox="1018 1115 1214 1142">Fan motor capacitors</p> <p data-bbox="895 1182 1150 1209">CJ_ODU_PCB_012-1</p>

Note: This section is for reference only. Actual unit appearance may vary.

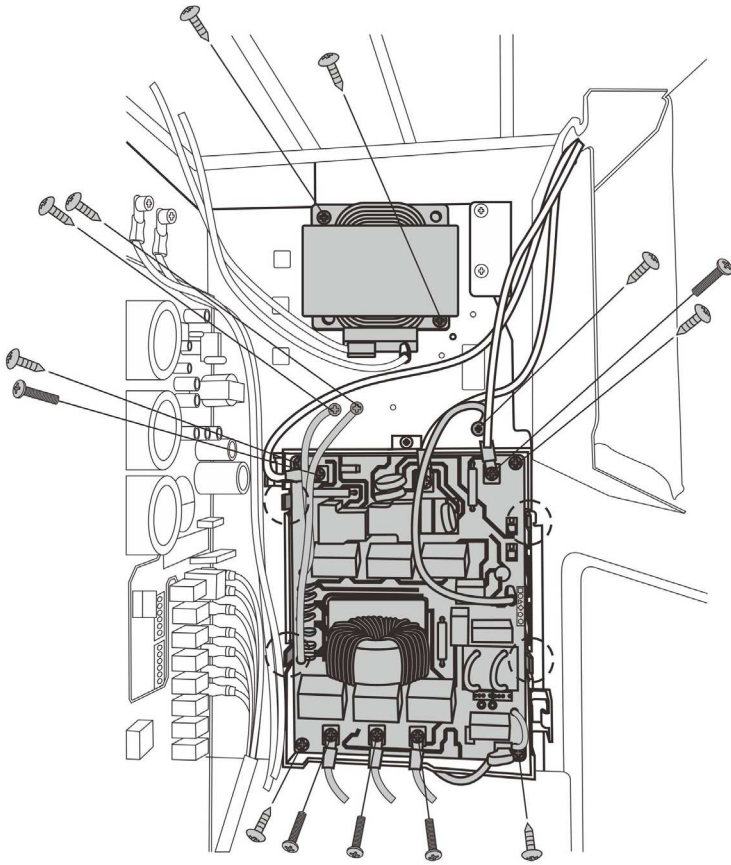
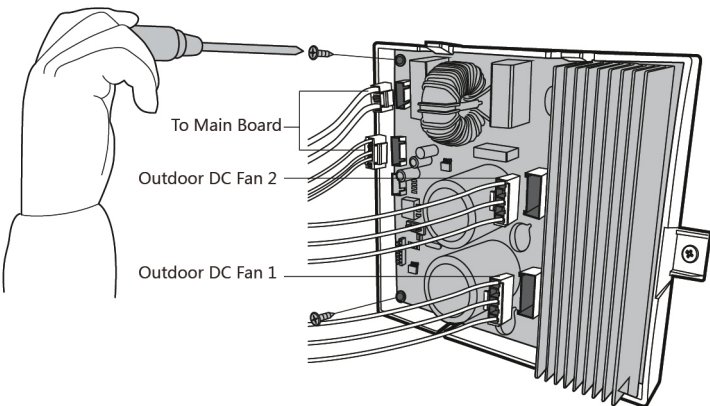
Procedure	Illustration
<p>6) Remove 3 screws to disconnect the power supply wires. (see CJ_ODU_PCB_012-1)</p> <p>7) Remove 3 screws to disconnect ground wires. (see CJ_ODU_PCB_012-1)</p> <p>8) Disconnect the wires connected to main control board. (see CJ_ODU_PCB_012-2)</p> <p>9) Remove the 4 screws and unfix the 4 hooks and then remove the filter board.(see CJ_ODU_PCB_012-2)</p> <p>10)Remove the 2 screws of the reactor and then remove it . (see CJ_ODU_PCB_012-2)</p>	 <p>The diagram shows the internal components of the outdoor unit PCB_012-2. A hand is shown using a screwdriver to remove screws from the top and sides of the unit. Wires are shown being disconnected from the main control board. The reactor is also shown being removed.</p>
<p>11)Disconnect the wires connected to main control board. (see CJ_ODU_PCB_012-3)(for some models)</p> <p>12)Remove the 2 screws and then remove the DC motor driver board. (see CJ_ODU_PCB_012-3)(for some models)</p>	 <p>The diagram shows the internal components of the outdoor unit PCB_012-3. A hand is shown using a screwdriver to remove screws from the top of the unit. Wires are shown being disconnected from the main control board. The DC motor driver board is also shown being removed.</p> <p style="text-align: center;">CJ_ODU_PCB_012-3 (for some models)</p>

Note: This section is for reference only. Actual unit appearance may vary.

13. PCB board 13

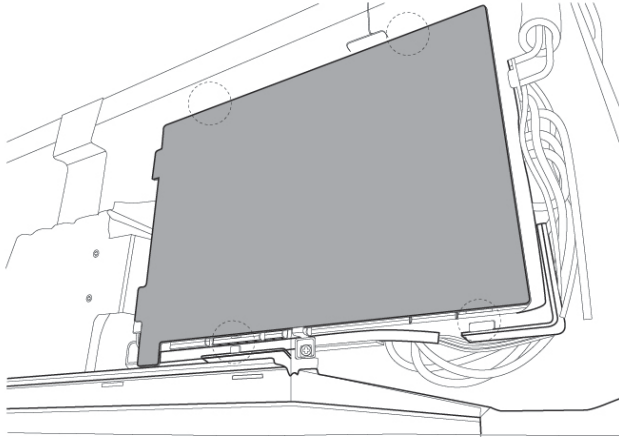
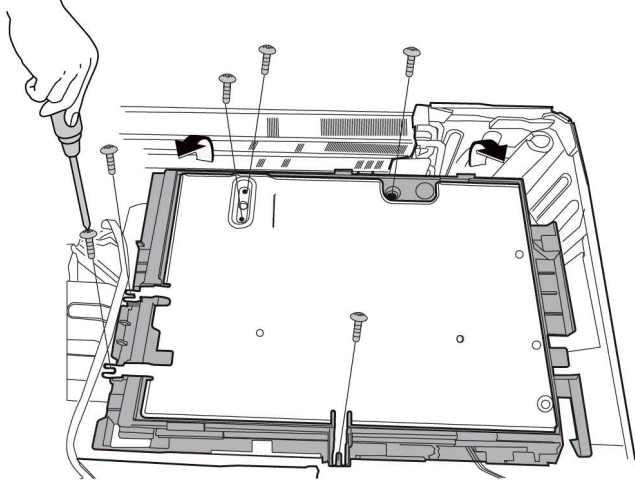
Procedure	Illustration
<p>1) Unfix the hooks and then open the electronic control box cover (4 hooks) (see CJ_ODU_PCB_013-1).</p>	 <p>CJ_ODU_PCB_013-1</p>
<p>2) Remove 6 screws on the electronic control board and then turn over the electronic control board (see CJ_ODU_PCB_013-2).</p>	 <p>CJ_ODU_PCB_013-2</p>

Note: This section is for reference only. Actual unit appearance may vary.

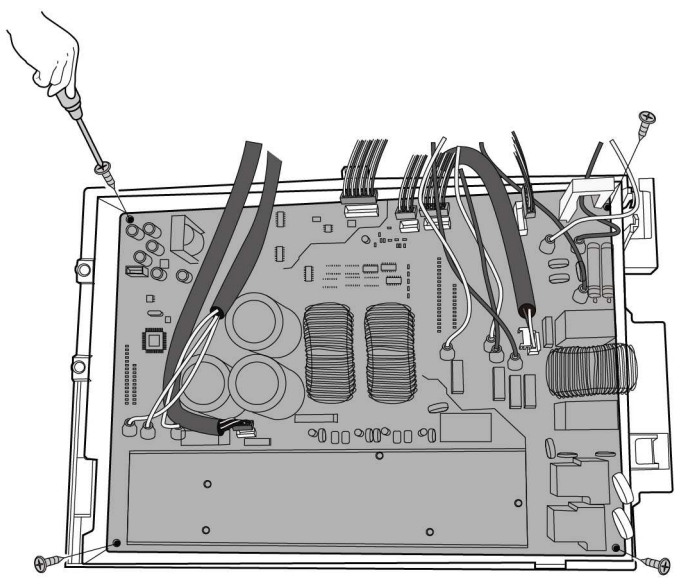
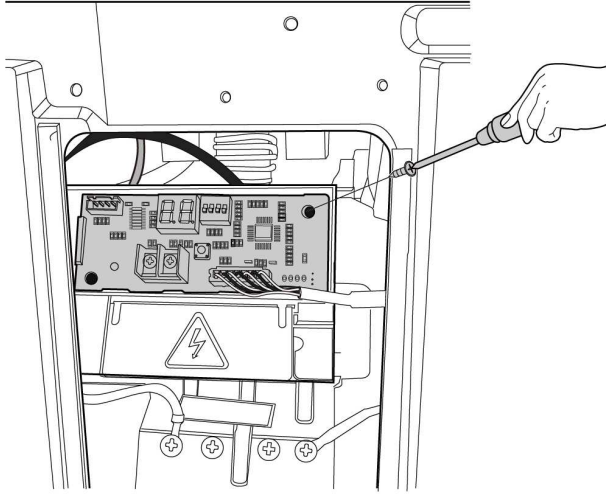
Procedure	Illustration
<p>3) Pull out the connectors (see CJ_ODU_PCB_013-3).</p> <p>4) Remove the 4 screws and then remove the electronic control board(see CJ_ODU_PCB_013-3).</p>	 <p style="text-align: center;">CJ_ODU_PCB_013-3</p>
<p>5) Pull out the connector, remove one screw and then remove the key board subassembly on terminal board. (see CJ_ODU_PCB_013-4) (for some units).</p>	 <p style="text-align: center;">CJ_ODU_PCB_013-4</p>

Note: This section is for reference only. Actual unit appearance may vary.

2.3 Fan Assembly

Note: Remove the panel plate (refer to 3.1 Panel Plate) before disassembling fan.

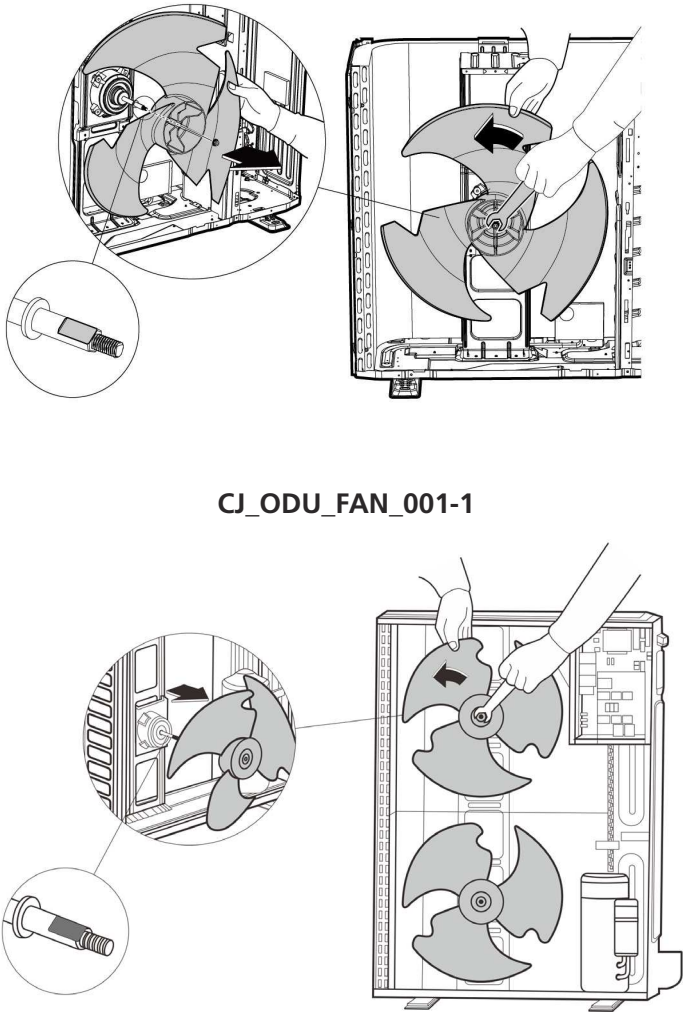
Procedure	Illustration
<p>1) Remove the nut securing the fan with a spanner (see CJ_ODU_FAN_001-1&2).</p> <p>2) Remove the fan.</p>	 <p data-bbox="874 996 1136 1030">CJ_ODU_FAN_001-1</p> <p data-bbox="874 1568 1136 1601">CJ_ODU_FAN_001-2</p>

Note: This section is for reference only. Actual unit appearance may vary.

2.4 Fan Motor

Note: Remove the panel plate and the connection of fan motor on PCB (refer to 3.1 Panel Plate and 3.2 Electrical parts) before disassembling fan motor.

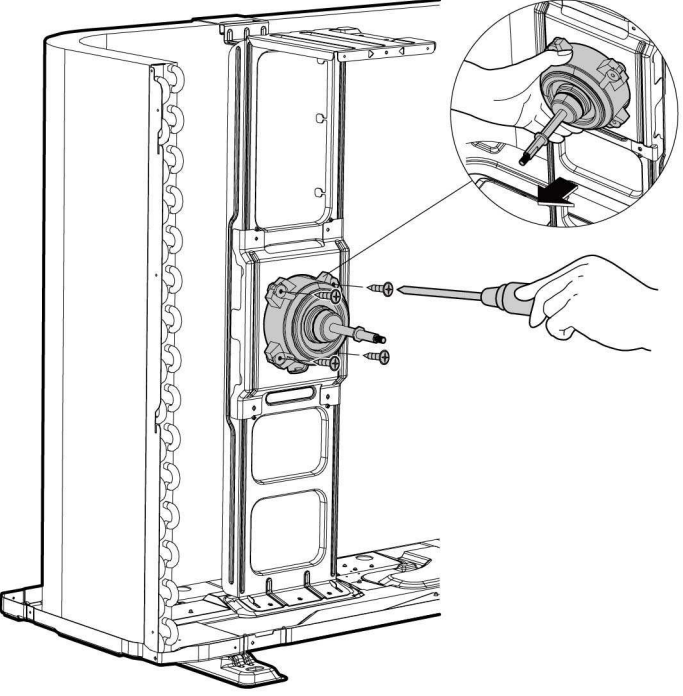
Procedure	Illustration
<p>3) Remove the fixing screws of the fan motor (4 screws) (see CJ_ODU_MOTOR_001).</p> <p>4) Remove the fan motor.</p>	 <p>The illustration shows a side view of an outdoor unit with its front panel removed. A hand is using a screwdriver to remove a screw from the fan motor. A circular inset provides a magnified view of the fan motor being held in place by four screws. The fan motor is mounted on a metal bracket. Below the illustration is the label 'CJ_ODU_MOTOR_001'.</p> <p data-bbox="898 1234 1182 1267">CJ_ODU_MOTOR_001</p>

Note: This section is for reference only. Actual unit appearance may vary.

2.5 Sound blanket

Note: Remove the panel plate (refer to 3.1 Panel plate) before disassembling sound blanket.

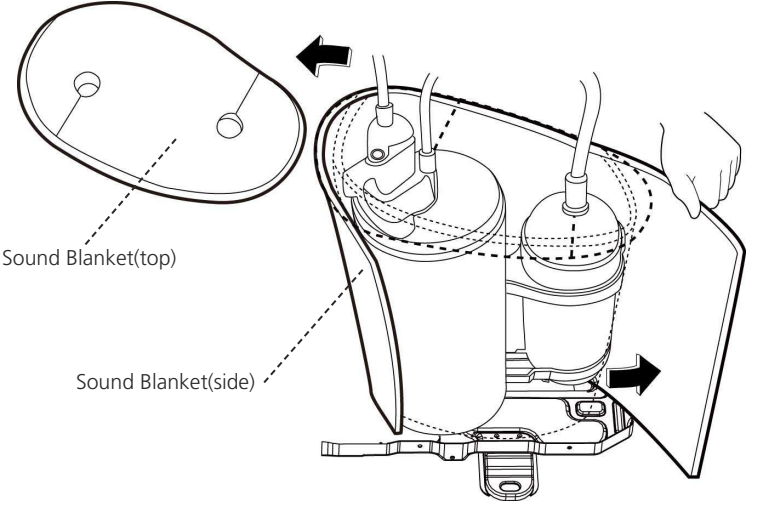
Procedure	Illustration
1) Remove the sound blanket (side and top) (see CJ_ODU_BLANKET_001).	 <p data-bbox="863 974 1166 1008">CJ_ODU_BLANKET_001</p>

Note: This section is for reference only. Actual unit appearance may vary.

2.6 Four-way valve (for heat pump models)

⚠ WARNING: Evacuate the system and confirm that there is no refrigerant left in the system before removing the four-way valve and the compressor. (For R32 & R290, you should evacuate the system with the vacuum pump; flush the system with nitrogen; then repeat the two steps before heating up the brazed parts. The operations above should be implemented by professionals.)

Note: Remove the panel plate, connection of four-way valve on PCB (refer to 3.1 Panel plate and 3.2 Electrical parts) before disassembling sound blanket.

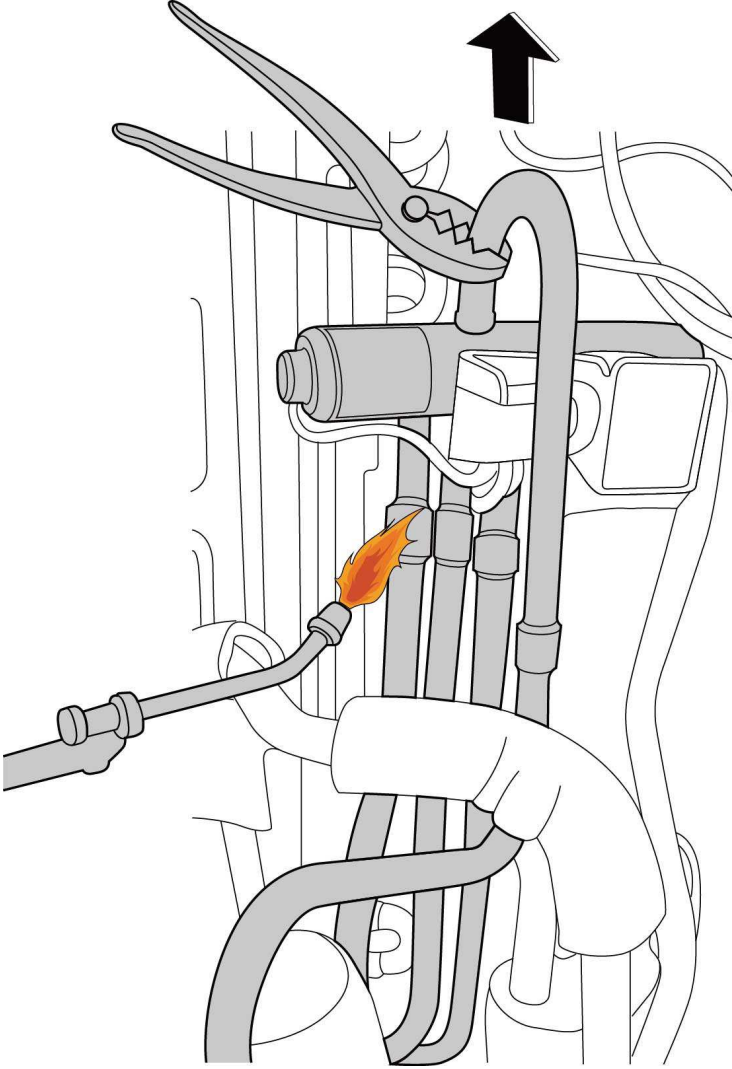
Procedure	Illustration
<ol style="list-style-type: none">1) Heat up the brazed parts and then detach the the four-way valve and the pipe (see CJ_ODU_VALVE_001).2) Remove the four-way valve assembly with pliers.	 <p data-bbox="906 1693 1171 1727">CJ_ODU_VALVE_001</p>

Note: This section is for reference only. Actual unit appearance may vary.

2.7 Compressor

⚠ WARNING: Evacuate the system and confirm that there is no refrigerant left in the system before removing the four-way valve and the compressor. (For R32 & R290, you should evacuate the system with the vacuum pump; flush the system with nitrogen; then repeat the two steps before heating up the brazed parts. The operations above should be implemented by professionals.)

Note: Remove the panel plate, connection of compressor on PCB (refer to 3.1 Panel plate and 3.2 Electrical parts) before disassembling sound blanket.

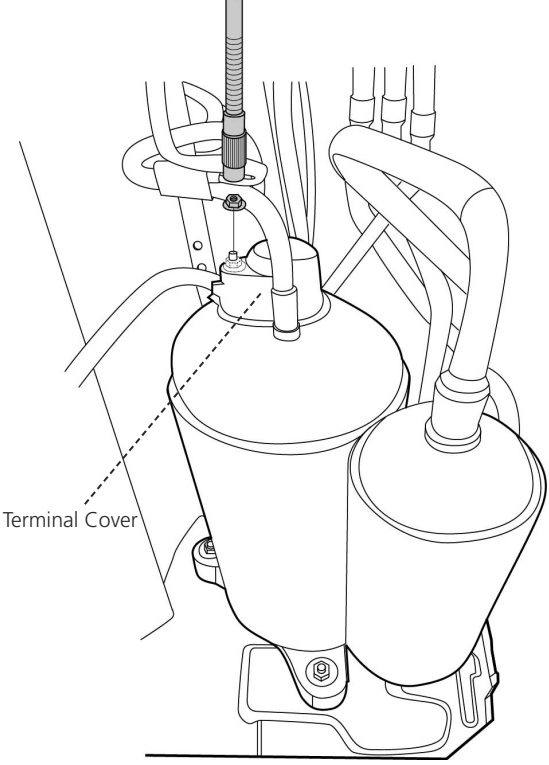
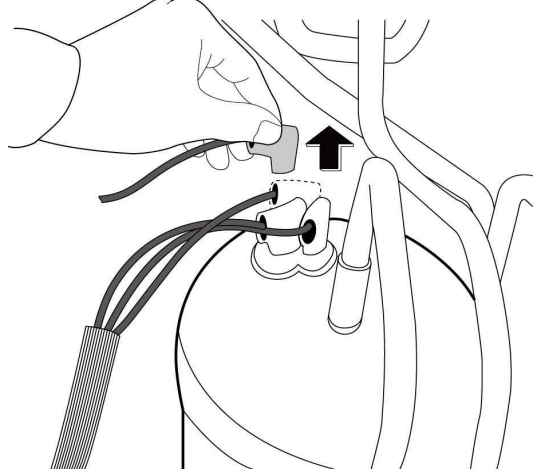
Procedure	Illustration
1) Remove the flange nut of terminal cover and remove the terminal cover (see CJ_ODU_COMP_001).	 <p data-bbox="906 1377 1173 1411">CJ_ODU_COMP_001</p>
2) Disconnect the connectors (see CJ_ODU_COMP_002).	 <p data-bbox="906 1926 1173 1960">CJ_ODU_COMP_002</p>

Note: This section is for reference only. Actual unit appearance may vary.

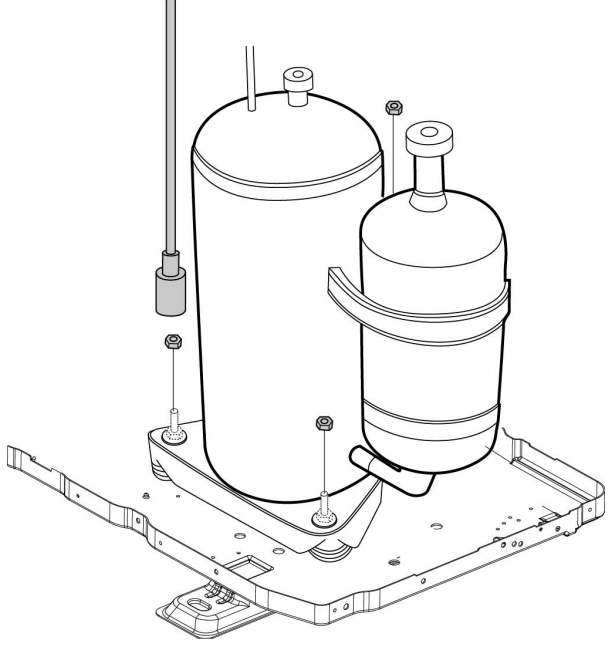
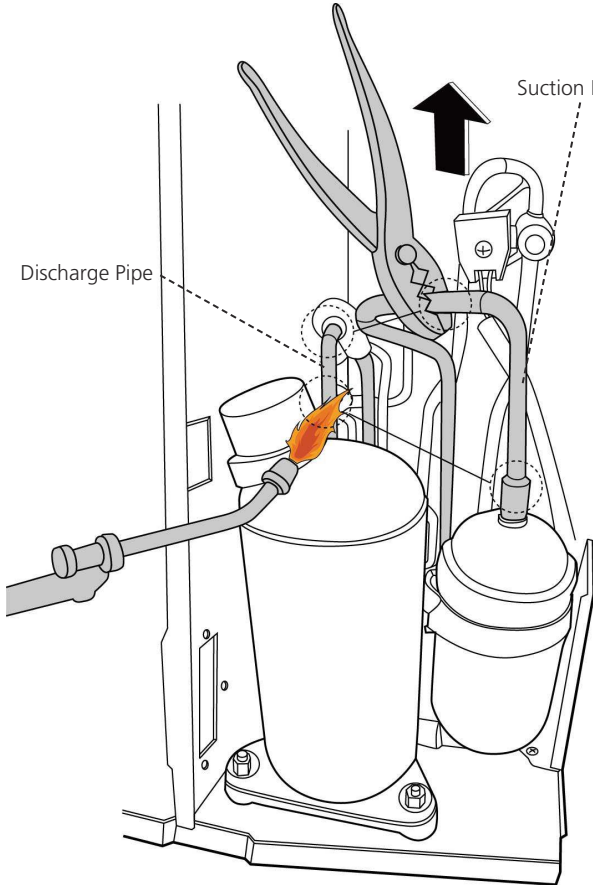
Procedure	Illustration
<p>3) Remove the hex nuts and washers securing the compressor, located on the bottom plate (see CJ_ODU_COMP_003).</p>	 <p style="text-align: center;">CJ_ODU_COMP_003</p>
<p>4) Heat up the brazed parts and then remove the the discharge pipe and the suction pipe (see CJ_ODU_COMP_004).</p> <p>5) Lift the compressor from the base pan assembly with pliers.</p>	 <p style="text-align: center;">CJ_ODU_COMP_004</p>

Note: This section is for reference only. Actual unit appearance may vary.

Appendix

Contents

i)	Temperature Sensor Resistance Value Table for T1, T2, T3, and T4 (°C – K)	2
ii)	Temperature Sensor Resistance Value Table for TP (for some units)(°C --K)	3
iii)	Pressure On Service Port	4

i) Temperature Sensor Resistance Value Table for T1,T2,T3 and T4 (°C – K)

°C	°F	K Ohm	°C	°F	K Ohm	°C	°F	K Ohm	°C	°F	K Ohm
-20	-4	115.266	20	68	12.6431	60	140	2.35774	100	212	0.62973
-19	-2	108.146	21	70	12.0561	61	142	2.27249	101	214	0.61148
-18	0	101.517	22	72	11.5	62	144	2.19073	102	216	0.59386
-17	1	96.3423	23	73	10.9731	63	145	2.11241	103	217	0.57683
-16	3	89.5865	24	75	10.4736	64	147	2.03732	104	219	0.56038
-15	5	84.219	25	77	10	65	149	1.96532	105	221	0.54448
-14	7	79.311	26	79	9.55074	66	151	1.89627	106	223	0.52912
-13	9	74.536	27	81	9.12445	67	153	1.83003	107	225	0.51426
-12	10	70.1698	28	82	8.71983	68	154	1.76647	108	226	0.49989
-11	12	66.0898	29	84	8.33566	69	156	1.70547	109	228	0.486
-10	14	62.2756	30	86	7.97078	70	158	1.64691	110	230	0.47256
-9	16	58.7079	31	88	7.62411	71	160	1.59068	111	232	0.45957
-8	18	56.3694	32	90	7.29464	72	162	1.53668	112	234	0.44699
-7	19	52.2438	33	91	6.98142	73	163	1.48481	113	235	0.43482
-6	21	49.3161	34	93	6.68355	74	165	1.43498	114	237	0.42304
-5	23	46.5725	35	95	6.40021	75	167	1.38703	115	239	0.41164
-4	25	44	36	97	6.13059	76	169	1.34105	116	241	0.4006
-3	27	41.5878	37	99	5.87359	77	171	1.29078	117	243	0.38991
-2	28	39.8239	38	100	5.62961	78	172	1.25423	118	244	0.37956
-1	30	37.1988	39	102	5.39689	79	174	1.2133	119	246	0.36954
0	32	35.2024	40	104	5.17519	80	176	1.17393	120	248	0.35982
1	34	33.3269	41	106	4.96392	81	178	1.13604	121	250	0.35042
2	36	31.5635	42	108	4.76253	82	180	1.09958	122	252	0.3413
3	37	29.9058	43	109	4.5705	83	181	1.06448	123	253	0.33246
4	39	28.3459	44	111	4.38736	84	183	1.03069	124	255	0.3239
5	41	26.8778	45	113	4.21263	85	185	0.99815	125	257	0.31559
6	43	25.4954	46	115	4.04589	86	187	0.96681	126	259	0.30754
7	45	24.1932	47	117	3.88673	87	189	0.93662	127	261	0.29974
8	46	22.5662	48	118	3.73476	88	190	0.90753	128	262	0.29216
9	48	21.8094	49	120	3.58962	89	192	0.8795	129	264	0.28482
10	50	20.7184	50	122	3.45097	90	194	0.85248	130	266	0.2777
11	52	19.6891	51	124	3.31847	91	196	0.82643	131	268	0.27078
12	54	18.7177	52	126	3.19183	92	198	0.80132	132	270	0.26408
13	55	17.8005	53	127	3.07075	93	199	0.77709	133	271	0.25757
14	57	16.9341	54	129	2.95896	94	201	0.75373	134	273	0.25125
15	59	16.1156	55	131	2.84421	95	203	0.73119	135	275	0.24512
16	61	15.3418	56	133	2.73823	96	205	0.70944	136	277	0.23916
17	63	14.6181	57	135	2.63682	97	207	0.68844	137	279	0.23338
18	64	13.918	58	136	2.53973	98	208	0.66818	138	280	0.22776
19	66	13.2631	59	138	2.44677	99	210	0.64862	139	282	0.22231

ii) Temperature Sensor Resistance Value Table for TP(for some units) (°C --K)

°C	°F	K Ohm	°C	°F	K Ohm	°C	°F	K Ohm	°C	°F	K Ohm
°C	°F	K Ohm	°C	°F	K Ohm	°C	°F	K Ohm	°C	°F	K Ohm
-20	-4	542.7	20	68	68.66	60	140	13.59	100	212	3.702
-19	-2	511.9	21	70	65.62	61	142	13.11	101	214	3.595
-18	0	483	22	72	62.73	62	144	12.65	102	216	3.492
-17	1	455.9	23	73	59.98	63	145	12.21	103	217	3.392
-16	3	430.5	24	75	57.37	64	147	11.79	104	219	3.296
-15	5	406.7	25	77	54.89	65	149	11.38	105	221	3.203
-14	7	384.3	26	79	52.53	66	151	10.99	106	223	3.113
-13	9	363.3	27	81	50.28	67	153	10.61	107	225	3.025
-12	10	343.6	28	82	48.14	68	154	10.25	108	226	2.941
-11	12	325.1	29	84	46.11	69	156	9.902	109	228	2.86
-10	14	307.7	30	86	44.17	70	158	9.569	110	230	2.781
-9	16	291.3	31	88	42.33	71	160	9.248	111	232	2.704
-8	18	275.9	32	90	40.57	72	162	8.94	112	234	2.63
-7	19	261.4	33	91	38.89	73	163	8.643	113	235	2.559
-6	21	247.8	34	93	37.3	74	165	8.358	114	237	2.489
-5	23	234.9	35	95	35.78	75	167	8.084	115	239	2.422
-4	25	222.8	36	97	34.32	76	169	7.82	116	241	2.357
-3	27	211.4	37	99	32.94	77	171	7.566	117	243	2.294
-2	28	200.7	38	100	31.62	78	172	7.321	118	244	2.233
-1	30	190.5	39	102	30.36	79	174	7.086	119	246	2.174
0	32	180.9	40	104	29.15	80	176	6.859	120	248	2.117
1	34	171.9	41	106	28	81	178	6.641	121	250	2.061
2	36	163.3	42	108	26.9	82	180	6.43	122	252	2.007
3	37	155.2	43	109	25.86	83	181	6.228	123	253	1.955
4	39	147.6	44	111	24.85	84	183	6.033	124	255	1.905
5	41	140.4	45	113	23.89	85	185	5.844	125	257	1.856
6	43	133.5	46	115	22.89	86	187	5.663	126	259	1.808
7	45	127.1	47	117	22.1	87	189	5.488	127	261	1.762
8	46	121	48	118	21.26	88	190	5.32	128	262	1.717
9	48	115.2	49	120	20.46	89	192	5.157	129	264	1.674
10	50	109.8	50	122	19.69	90	194	5	130	266	1.632
11	52	104.6	51	124	18.96	91	196	4.849			
12	54	99.69	52	126	18.26	92	198	4.703			
13	55	95.05	53	127	17.58	93	199	4.562			
14	57	90.66	54	129	16.94	94	201	4.426			
15	59	86.49	55	131	16.32	95	203	4.294			
16	61	82.54	56	133	15.73	96	205	4.167			
17	63	78.79	57	135	15.16	97	207	4.045			
18	64	75.24	58	136	14.62	98	208	3.927			
19	66	71.86	59	138	14.09	99	210	3.812			

iii) Pressure On Service Port

Cooling chart(R410A):

°F(°C)	ODU(DB)		0(-17)	5(-15)	15(-9.44)	45(7.22)	75(23.89)	85(29.44)	95(35)	105(40.56)	115(46.11)	120(48.89)
	IDU(DB/WB)											
BAR	70/59 (21.11/15)		6.4	6.5	7.3	8.0	8.2	7.8	8.1	8.6	10.1	10.6
	75/63 (23.89/17.22)		6.7	6.8	7.9	8.6	8.6	8.3	8.7	9.1	10.7	11.2
	80/67 (26.67/19.44)		7.1	7.2	8.5	9.5	9.3	8.9	9.1	9.6	11.2	11.9
	90/73 (32.22/22.78)		7.7	7.8	9.6	10.5	10.3	9.5	10.0	10.6	12.4	13.0
PSI	70/59 (21.11/15)		93	94	106	116	119	113	117	125	147	154
	75/63 (23.89/17.22)		97	99	115	125	124	120	126	132	155	162
	80/67 (26.67/19.44)		103	104	123	138	135	129	132	140	162	173
	90/73 (32.22/22.78)		112	113	139	152	149	138	145	154	180	189
MPa	70/59 (21.11/15)		0.64	0.65	0.73	0.8	0.82	0.78	0.81	0.86	1.01	1.06
	75/63 (23.89/17.22)		0.67	0.68	0.79	0.86	0.86	0.83	0.87	0.91	1.07	1.12
	80/67 (26.67/19.44)		0.71	0.72	0.85	0.95	0.93	0.89	0.91	0.96	1.12	1.19
	90/73 (32.22/22.78)		0.77	0.78	0.96	1.05	1.03	0.95	1	1.06	1.24	1.3

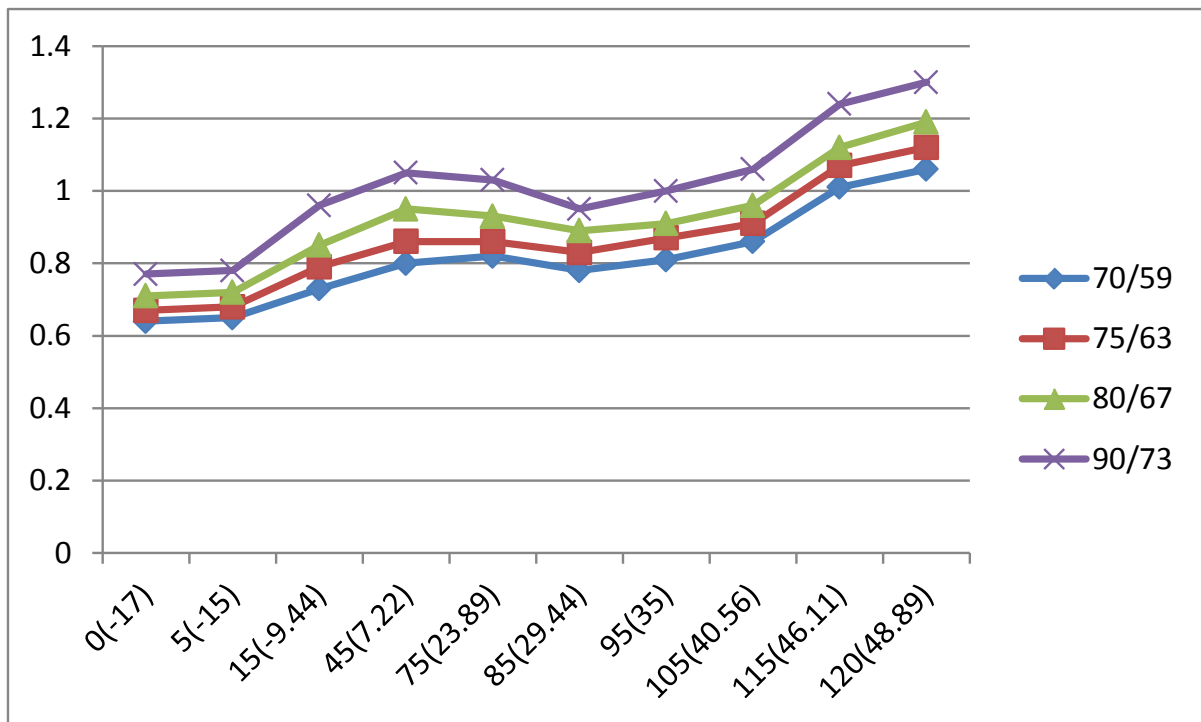

Heating chart(R410A):

°F(°C)	ODU(DB/WB)	57/53 (13.89/11.67)	47/43 (8.33/6.11)	37/33 (2.78/0.56)	27/23 (-2.78/-5)	17/13 (-8.33/ -10.56)	0/-2 (-17/-19)	-17/-18 (-27/-28)
	IDU(DB)							
BAR	55(12.78)	30.3	28.5	25.3	22.8	20.8	18.5	16.5
	65(18.33)	32.5	30.0	26.6	25.4	23.3	20.5	19.0
	75(23.89)	33.8	31.5	27.8	26.3	24.9	21.5	20.0
PSI	55(12.78)	439	413	367	330	302	268	239
	65(18.33)	471	435	386	368	339	297	276
	75(23.89)	489	457	403	381	362	312	290
MPa	55(12.78)	3.03	2.85	2.53	2.28	2.08	1.85	1.65
	65(18.33)	3.25	3.00	2.66	2.54	2.33	2.05	1.90
	75(23.89)	3.38	3.15	2.78	2.63	2.49	2.15	2.00

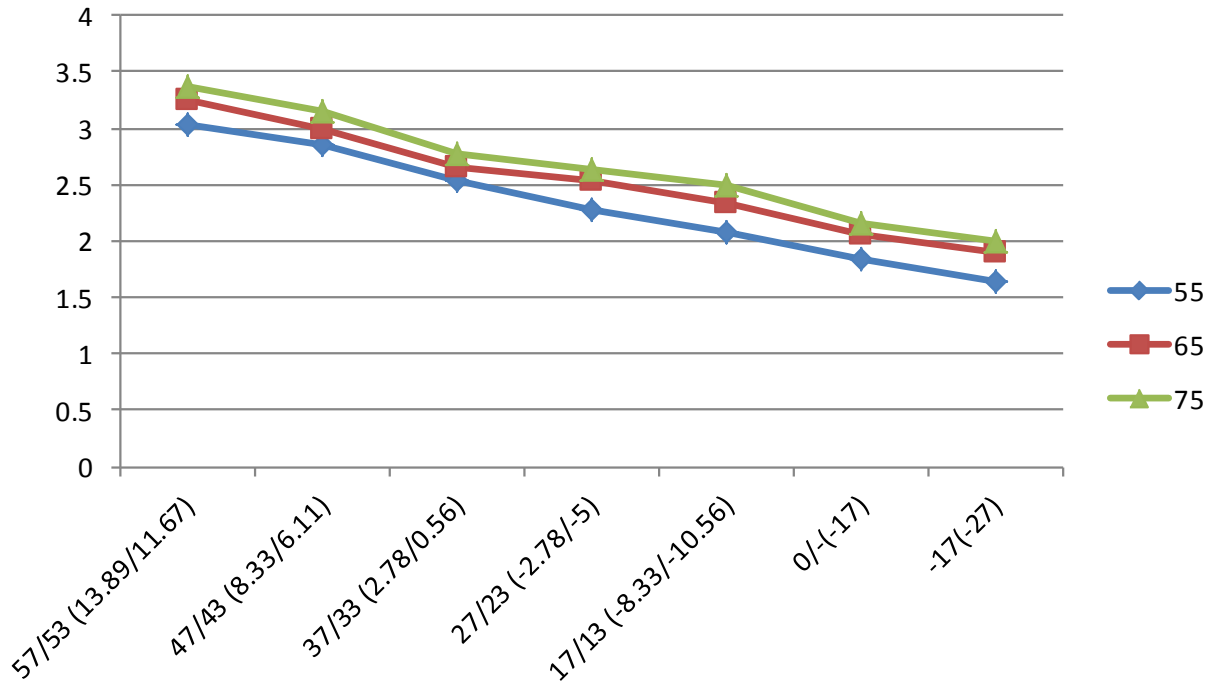

Cooling chart(R22):

°F(°C)	ODU(DB)		0(-17)	5(-15)	15(-9.44)	45(7.22)	75(23.89)	85(29.44)	95(35)	105(40.56)	115(46.11)	120(48.89)
	IDU(DB/WB)											
BAR	70/59 (21.11/15)		4.0	4.1	4.6	5.0	5.1	4.9	5.1	5.4	6.3	6.6
	75/63 (23.89/17.22)		4.2	4.3	4.9	5.4	5.4	5.2	5.4	5.7	6.7	7.0
	80/67 (26.67/19.44)		4.4	4.5	5.3	5.9	5.8	5.6	5.7	6.0	7.0	7.4
	90/73 (32.22/22.78)		4.8	4.9	6.0	6.6	6.4	5.9	6.3	6.6	7.8	8.1
PSI	70/59 (21.11/15)		58	59	67	73	74	71	74	78	91	96
	75/63 (23.89/17.22)		61	62	71	78	78	75	78	83	97	102
	80/67 (26.67/19.44)		64	65	77	86	84	81	83	87	102	107
	90/73 (32.22/22.78)		70	71	87	96	93	86	91	96	113	117
MPa	70/59 (21.11/15)		0.40	0.41	0.46	0.50	0.51	0.49	0.51	0.54	0.63	0.66
	75/63 (23.89/17.22)		0.42	0.43	0.49	0.54	0.54	0.52	0.54	0.57	0.67	0.70
	80/67 (26.67/19.44)		0.44	0.45	0.53	0.59	0.58	0.56	0.57	0.60	0.70	0.74
	90/73 (32.22/22.78)		0.48	0.49	0.60	0.66	0.64	0.59	0.63	0.66	0.78	0.81

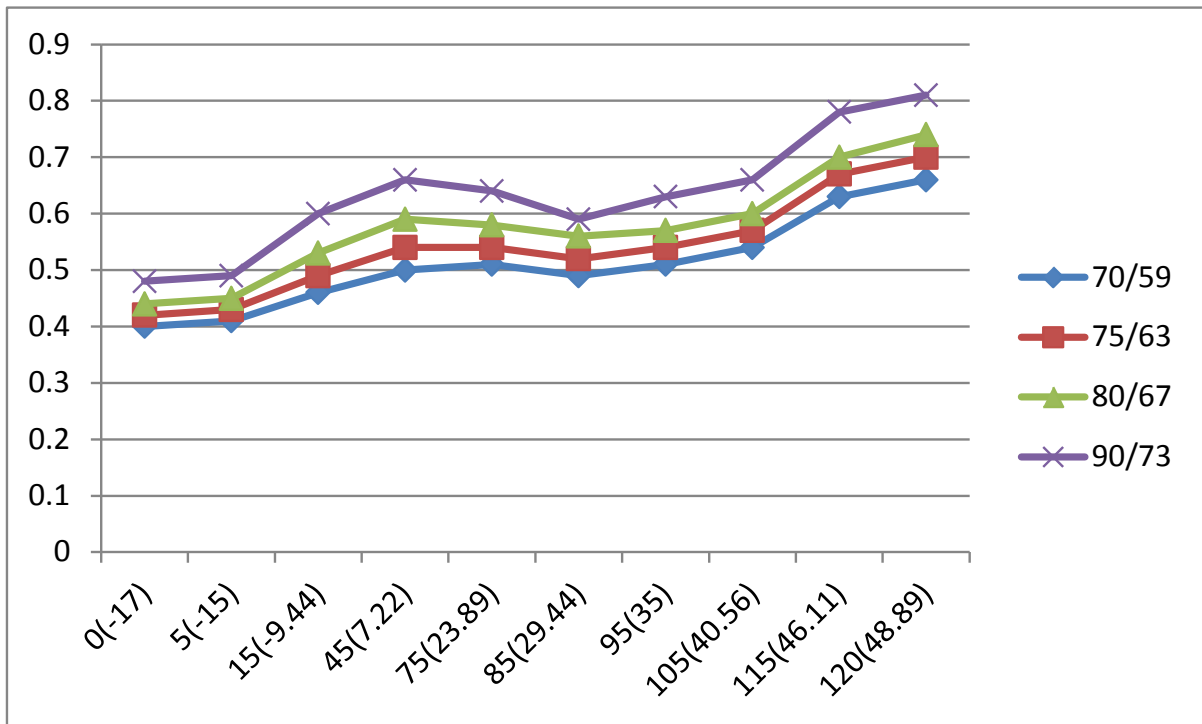

Heating chart(R22):

°F(°C)	ODU(DB/WB)	57/53 (13.89/11.67)	47/43 (8.33/6.11)	37/33 (2.78/0.56)	27/23 (-2.78/-5)	17/13 (-8.33/ -10.56)	0/-2 (-17/-19)	-17/-18 (-27/-28)
	IDU(DB)							
BAR	55(12.78)	18.9	17.8	15.8	14.3	13.0	11.6	10.3
	65(18.33)	20.3	18.8	16.6	15.9	14.6	12.8	11.9
	75(23.89)	21.1	19.7	17.3	16.4	15.6	13.4	12.5
PSI	55(12.78)	274	258	229	207	189	168	149
	65(18.33)	294	273	241	231	212	186	172.6
	75(23.89)	306	286	251	238	226	194	181
MPa	55(12.78)	1.89	1.78	1.58	1.43	1.30	1.16	1.03
	65(18.33)	2.03	1.88	1.66	1.59	1.46	1.28	1.19
	75(23.89)	2.11	1.97	1.73	1.64	1.56	1.34	1.25

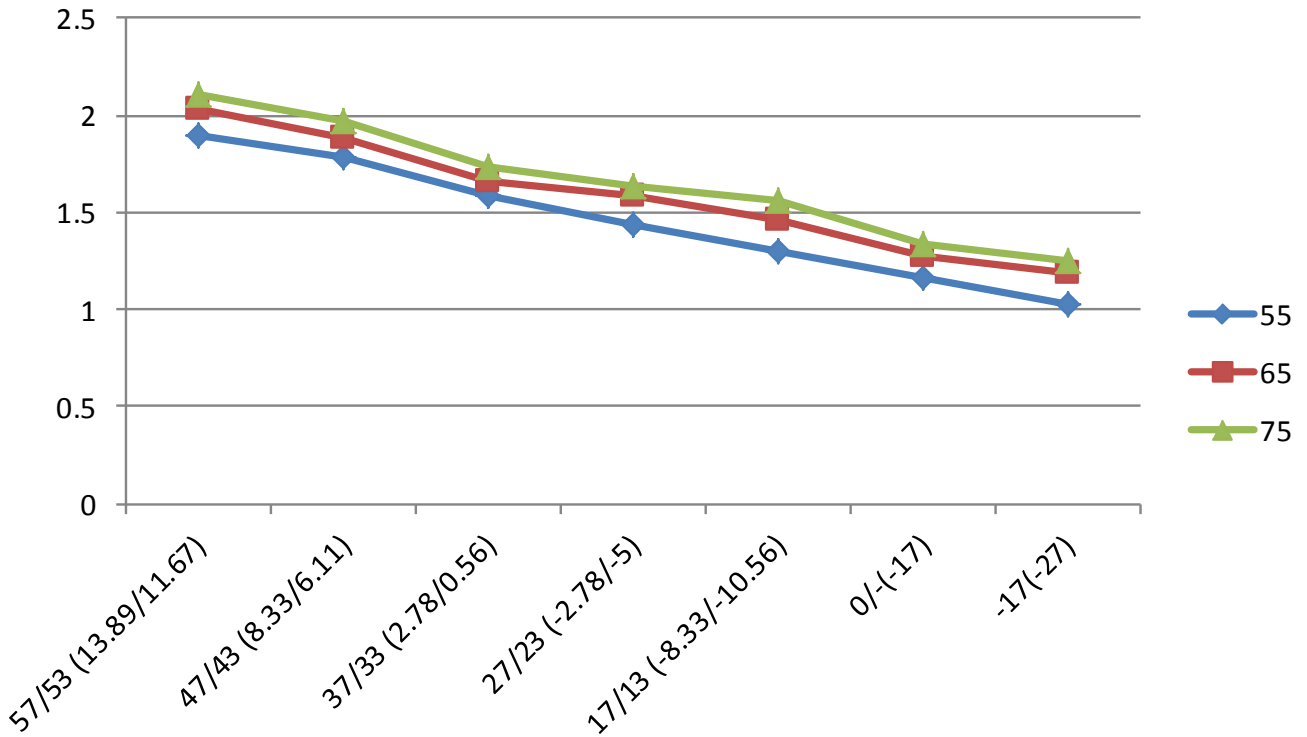

Cooling chart(R32):

°F(°C)	ODU(DB)		0(-17)	5(-15)	15(-9.44)	45(7.22)	75(23.89)	85(29.44)	95(35)	105(40.56)	115(46.11)	120(48.89)
	IDU(DB/WB)											
BAR	70/59 (21.11/15)		6.5	6.6	7.4	8.2	8.4	8.0	8.3	8.8	10.3	10.8
	75/63 (23.89/17.22)		6.8	6.9	8.1	8.8	8.8	8.5	8.9	9.3	10.9	11.4
	80/67 (26.67/19.44)		7.2	7.3	8.7	9.7	9.5	9.1	9.3	9.8	11.4	12.1
	90/73 (32.22/22.78)		7.9	8.0	9.8	10.7	10.5	9.7	10.2	10.8	12.6	13.3
PSI	70/59 (21.11/15)		95	96	108	118	121	115	119	128	150	157
	75/63 (23.89/17.22)		99	101	117	128	126	122	129	135	158	165
	80/67 (26.67/19.44)		105	106	125	141	138	132	135	143	165	176
	90/73 (32.22/22.78)		114	115	142	155	152	141	148	157	184	193
MPa	70/59 (21.11/15)		0.65	0.66	0.74	0.82	0.84	0.80	0.83	0.88	1.03	1.08
	75/63 (23.89/17.22)		0.68	0.69	0.81	0.88	0.88	0.85	0.89	0.93	1.09	1.14
	80/67 (26.67/19.44)		0.72	0.73	0.87	0.97	0.95	0.91	0.93	0.98	1.14	1.21
	90/73 (32.22/22.78)		0.79	0.80	0.98	1.07	1.05	0.97	1.02	1.08	1.26	1.33

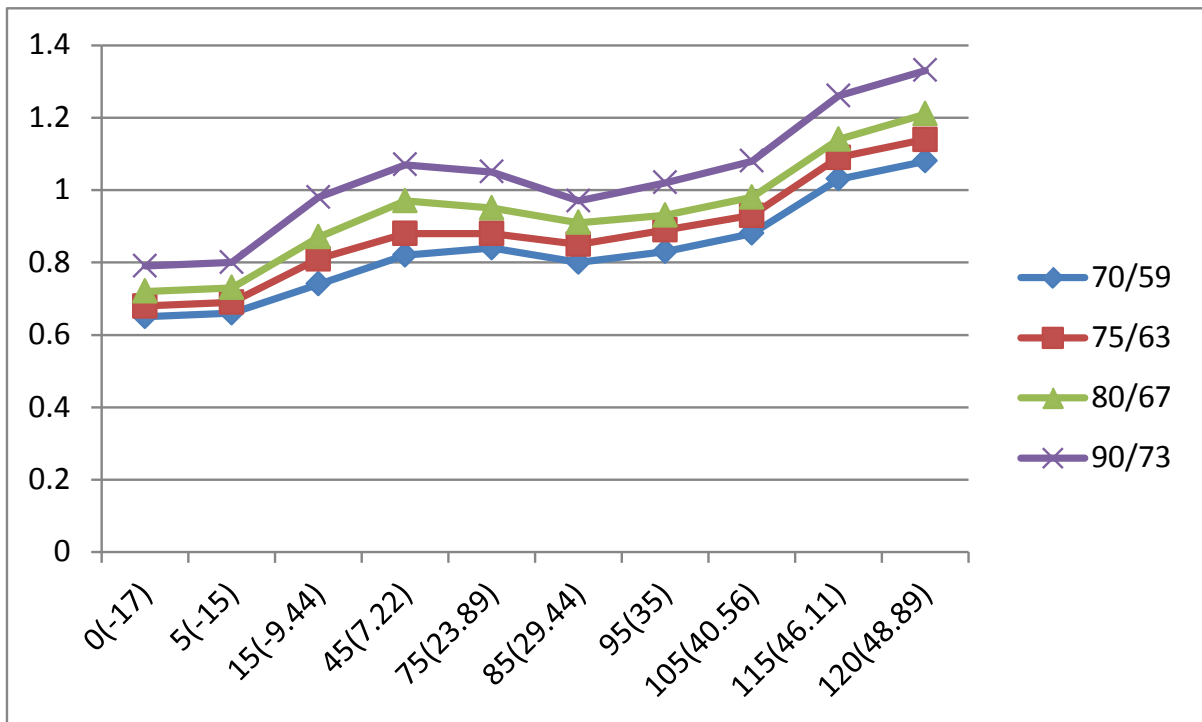

Heating chart(R32):

°F(°C)	ODU(DB/WB)	57/53 (13.89/11.67)	47/43 (8.33/6.11)	37/33 (2.78/0.56)	27/23 (-2.78/-5)	17/13 (-8.33/- 10.56)	0/-2 (-17/-19)	-17/-18 (-27/-28)
	IDU(DB)							
BAR	55(12.78)	30.9	29.1	25.8	23.3	21.2	18.9	16.8
	65(18.33)	33.2	30.6	27.1	25.9	23.8	20.9	19.4
	75(23.89)	34.5	32.1	28.4	26.8	25.4	21.9	20.4
PSI	55(12.78)	448	421	374	337	308	273	244
	65(18.33)	480	444	394	375	346	303	282
	75(23.89)	499	466	411	389	369	318	296
MPa	55(12.78)	3.09	2.91	2.58	2.33	2.12	1.89	1.68
	65(18.33)	3.32	3.06	2.71	2.59	2.38	2.09	1.94
	75(23.89)	3.45	3.21	2.84	2.68	2.54	2.19	2.04

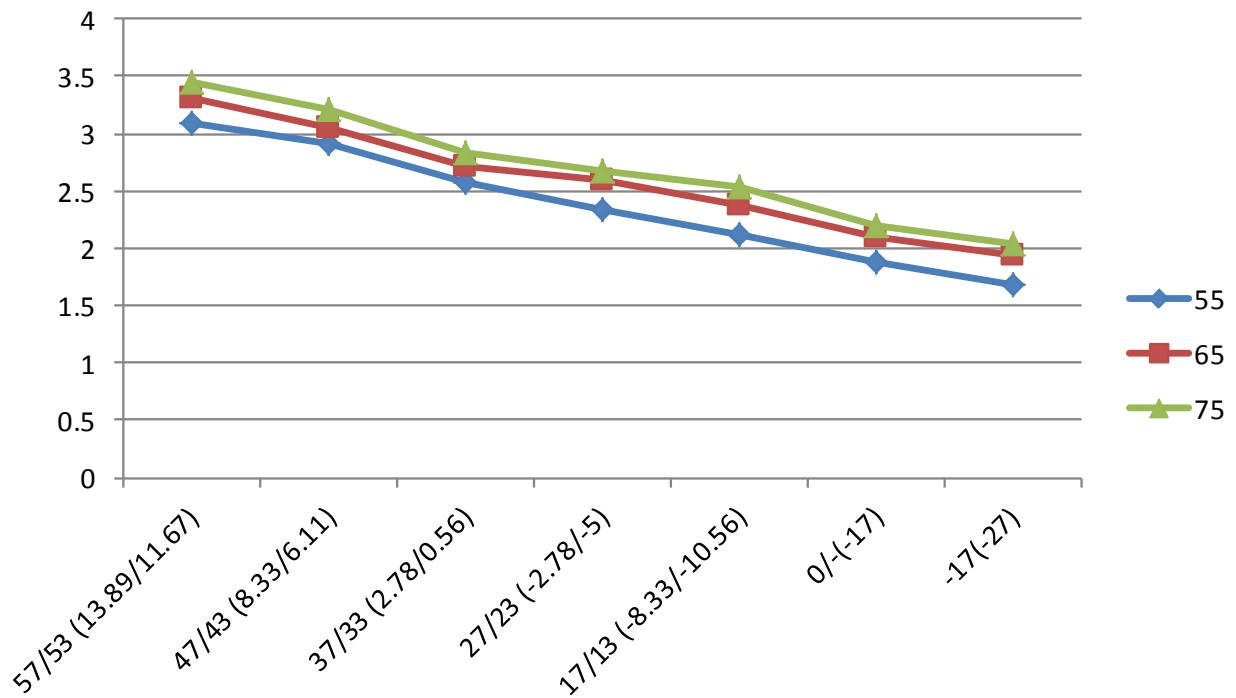

System Pressure Table-R22

Pressure			Temperature		Pressure			Temperature	
Kpa	bar	PSI	°C	°F	Kpa	bar	PSI	°C	°F
100	1	14.5	-41.091	-41.964	1600	16	232	41.748	107.146
150	1.5	21.75	-32.077	-25.739	1650	16.5	239.25	43.029	109.452
200	2	29	-25.177	-13.319	1700	17	246.5	44.281	111.706
250	2.5	36.25	-19.508	-3.114	1750	17.5	253.75	45.506	113.911
300	3	43.5	-14.654	5.623	1800	18	261	46.706	116.071
350	3.5	50.75	-10.384	13.309	1850	18.5	268.25	47.882	118.188
400	4	58	-6.556	20.199	1900	19	275.5	49.034	120.261
450	4.5	65.25	-3.075	26.464	1950	19.5	282.75	50.164	122.295
500	5	72.5	0.124	32.223	2000	20	290	51.273	124.291
550	5.5	79.75	3.091	37.563	2050	20.5	297.25	52.361	126.250
600	6	87	5.861	42.550	2100	21	304.5	53.43	128.174
650	6.5	94.25	8.464	47.234	2150	21.5	311.75	54.48	130.064
700	7	101.5	10.92	51.656	2200	22	319	55.512	131.922
750	7.5	108.75	13.249	55.848	2250	22.5	326.25	56.527	133.749
800	8	116	15.465	59.837	2300	23	333.5	57.526	135.547
850	8.5	123.25	17.58	63.644	2350	23.5	340.75	58.508	137.314
900	9	130.5	19.604	67.287	2400	24	348	59.475	139.055
950	9.5	137.75	21.547	70.785	2450	24.5	355.25	60.427	140.769
1000	10	145	23.415	74.147	2500	25	362.5	61.364	142.455
1050	10.5	152.25	25.216	77.389	2550	25.5	369.75	62.288	144.118
1100	11	159.5	26.953	80.515	2600	26	377	63.198	145.756
1150	11.5	166.75	28.634	83.541	2650	26.5	384.25	64.095	147.371
1200	12	174	30.261	86.470	2700	27	391.5	64.98	148.964
1250	12.5	181.25	31.839	89.310	2750	27.5	398.75	65.852	150.534
1300	13	188.5	33.371	92.068	2800	28	406	66.712	152.082
1350	13.5	195.75	34.86	94.748	2850	28.5	413.25	67.561	153.610
1400	14	203	36.308	97.354	2900	29	420.5	68.399	155.118
1450	14.5	210.25	37.719	99.894	2950	29.5	427.75	69.226	156.607
1500	15	217.5	39.095	102.371	3000	30	435	70.042	158.076
1550	15.5	224.75	40.437	104.787					

System Pressure Table-R410A

Pressure			Temperature		Pressure			Temperature	
Kpa	bar	PSI	°C	°F	Kpa	bar	PSI	°C	°F
100	1	14.5	-51.623	-60.921	2350	23.5	340.75	38.817	101.871
150	1.5	21.75	-43.327	-45.989	2400	24	348	39.68	103.424
200	2	29	-36.992	-34.586	2450	24.5	355.25	40.531	104.956
250	2.5	36.25	-31.795	-25.231	2500	25	362.5	41.368	106.462
300	3	43.5	-27.351	-17.232	2550	25.5	369.75	42.192	107.946
350	3.5	50.75	-23.448	-10.206	2600	26	377	43.004	109.407
400	4	58	-19.953	-3.915	2650	26.5	384.25	43.804	110.847
450	4.5	65.25	-16.779	1.798	2700	27	391.5	44.592	112.266
500	5	72.5	-13.863	7.047	2750	27.5	398.75	45.37	113.666
550	5.5	79.75	-11.162	11.908	2800	28	406	46.136	115.045
600	6	87	-8.643	16.444	2850	28.5	413.25	46.892	116.406
650	6.5	94.25	-6.277	20.701	2900	29	420.5	47.638	117.748
700	7	101.5	-4.046	24.716	2950	29.5	427.75	48.374	119.073
750	7.5	108.75	-1.933	28.521	3000	30	435	49.101	120.382
800	8	116	0.076	32.137	3050	30.5	442.25	49.818	121.672
850	8.5	123.25	1.993	35.587	3100	31	449.5	50.525	122.945
900	9	130.5	3.826	38.888	3150	31.5	456.75	51.224	124.203
950	9.5	137.75	5.584	42.052	3200	32	464	51.914	125.445
1000	10	145	7.274	45.093	3250	32.5	471.25	52.596	126.673
1050	10.5	152.25	8.901	48.022	3300	33	478.5	53.27	127.886
1100	11	159.5	10.471	50.848	3350	33.5	485.75	53.935	129.083
1150	11.5	166.75	11.988	53.578	3400	34	493	54.593	130.267
1200	12	174	13.457	56.223	3450	34.5	500.25	55.243	131.437
1250	12.5	181.25	14.879	58.782	3500	35	507.5	55.885	132.593
1300	13	188.5	16.26	61.268	3550	35.5	514.75	56.52	133.736
1350	13.5	195.75	17.602	63.684	3600	36	522	57.148	134.866
1400	14	203	18.906	66.031	3650	36.5	529.25	57.769	135.984
1450	14.5	210.25	20.176	68.317	3700	37	536.5	58.383	137.089
1500	15	217.5	21.414	70.545	3750	37.5	543.75	58.99	138.182
1550	15.5	224.75	22.621	72.718	3800	38	551	59.591	139.264
1600	16	232	23.799	74.838	3850	38.5	558.25	60.185	140.333
1650	16.5	239.25	24.949	76.908	3900	39	565.5	60.773	141.391
1700	17	246.5	26.074	78.933	3950	39.5	572.75	61.355	142.439
1750	17.5	253.75	27.174	80.913	4000	40	580	61.93	143.474
1800	18	261	28.251	82.852	4050	40.5	587.25	62.499	144.498
1850	18.5	268.25	29.305	84.749	4100	41	594.5	63.063	145.513
1900	19	275.5	30.338	86.608	4150	41.5	601.75	63.62	146.516
1950	19.5	282.75	31.351	88.432	4200	42	609	64.172	147.510
2000	20	290	32.344	90.219	4250	42.5	616.25	64.719	148.494
2050	20.5	297.25	33.319	91.974	4300	43	623.5	65.259	149.466
2100	21	304.5	34.276	93.697	4350	43.5	630.75	65.795	150.431
2150	21.5	311.75	35.215	95.387	4400	44	638	66.324	151.383
2200	22	319	36.139	97.050	4450	44.5	645.25	66.849	152.328
2250	22.5	326.25	37.047	98.685	4500	45	652.5	67.368	153.262
2300	23	333.5	37.939	100.290					

System Pressure Table-R32

Pressure			Temperature		Pressure			Temperature	
Kpa	bar	PSI	°C	°F	Kpa	bar	PSI	°C	°F
100	1	14.5	-51.909	-61.436	1850	18.5	268.25	28.425	83.165
150	1.5	21.75	-43.635	-46.543	1900	19	275.5	29.447	85.005
200	2	29	-37.323	-35.181	1950	19.5	282.75	30.448	86.806
250	2.5	36.25	-32.15	-25.87	2000	20	290	31.431	88.576
300	3	43.5	-27.731	-17.916	2050	20.5	297.25	32.395	90.311
350	3.5	50.75	-23.85	-10.93	2100	21	304.5	33.341	92.014
400	4	58	-20.378	-4.680	2150	21.5	311.75	34.271	93.688
450	4.5	65.25	-17.225	0.995	2200	22	319	35.184	95.331
500	5	72.5	-14.331	6.204	2250	22.5	326.25	36.082	96.948
550	5.5	79.75	-11.65	11.03	2300	23	333.5	36.965	98.537
600	6	87	-9.150	15.529	2350	23.5	340.75	37.834	100.101
650	6.5	94.25	-6.805	19.752	2400	24	348	38.688	101.638
700	7	101.5	-4.593	23.734	2450	24.5	355.25	39.529	103.152
750	7.5	108.75	-2.498	27.505	2500	25	362.5	40.358	104.644
800	8	116	-0.506	31.089	2550	25.5	369.75	41.173	106.111
850	8.5	123.25	1.393	34.507	2600	26	377	41.977	107.559
900	9	130.5	3.209	37.777	2650	26.5	384.25	42.769	108.984
950	9.5	137.75	4.951	40.911	2700	27	391.5	43.55	110.39
1000	10	145	6.624	43.923	2750	27.5	398.75	44.32	111.776
1050	10.5	152.25	8.235	46.823	2800	28	406	45.079	113.142
1100	11	159.5	9.790	49.621	2850	28.5	413.25	45.828	114.490
1150	11.5	166.75	11.291	52.324	2900	29	420.5	46.567	115.821
1200	12	174	12.745	54.941	2950	29.5	427.75	47.296	117.133
1250	12.5	181.25	14.153	57.475	3000	30	435	48.015	118.427
1300	13	188.5	15.52	59.936	3050	30.5	442.25	48.726	119.707
1350	13.5	195.75	16.847	62.325	3100	31	449.5	49.428	120.970
1400	14	203	18.138	64.648	3150	31.5	456.75	50.121	122.218
1450	14.5	210.25	19.395	66.911	3200	32	464	50.806	123.451
1500	15	217.5	20.619	69.114	3250	32.5	471.25	51.482	124.668
1550	15.5	224.75	21.813	71.263	3300	33	478.5	52.15	125.87
1600	16	232	22.978	73.360	3350	33.5	485.75	52.811	127.060
1650	16.5	239.25	24.116	75.409	3400	34	493	53.464	128.235
1700	17	246.5	25.229	77.412	3450	34.5	500.25	54.11	129.398
1750	17.5	253.75	26.317	79.371	3500	35	507.5	54.748	130.546
1800	18	261	27.382	81.288					